

MiniOX® 3000 Oxygen Monitor

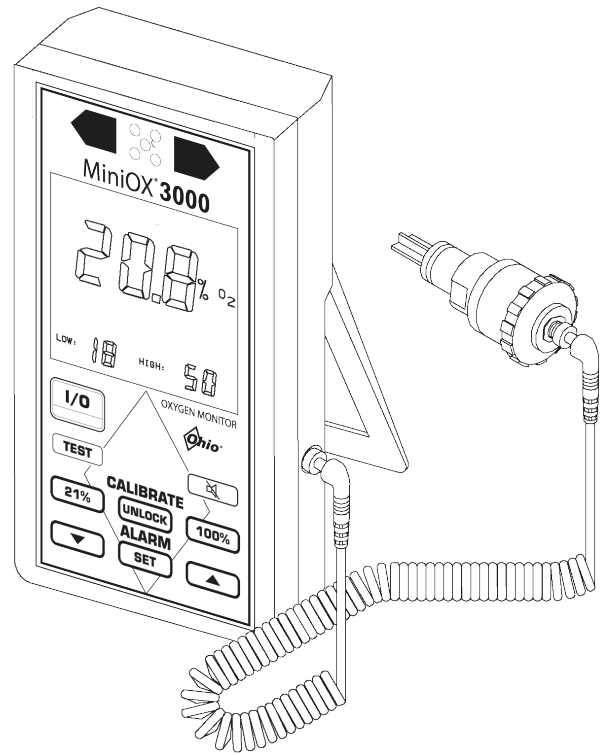

Operation Manual

⚠ WARNING

THIS MANUAL MUST BE READ CAREFULLY PRIOR TO THE OPERATION OF THIS DEVICE. THIS DEVICE WILL PERFORM AS DESIGNED ONLY IF USED IN ACCORDANCE WITH THE MANUFACTURER'S INSTRUCTIONS. IMPROPER USE MAY CAUSE THE DEVICE TO FAIL TO PERFORM AS DESIGNED AND MAY CAUSE INJURY TO THE PATIENT AND/OR HEALTHCARE PROFESSIONAL.

The warranties made by Ohio Medical Corporation® with respect to these products are voided if the products are not installed, used and serviced in accordance with the instructions in this manual. Please protect yourself and your patients by following them. We encourage our customers to write or call regarding this equipment prior to use or for any additional information relative to use or repairs.

This product is not intended as a life-sustaining or life-supporting device.

FEDERAL (USA) LAW RESTRICTS THIS DEVICE TO BE SOLD BY OR ON THE ORDER OF A PHYSICIAN

Ohio Medical Corporation®

Medical Instrument Warranty

This product is sold by Ohio Medical™ under the warranties set forth in the following paragraphs. Such warranties are extended only with respect to the purchase of this product directly from Ohio Medical or Ohio Medical's Authorized Dealers as new merchandise and are extended to the first Buyer thereof, other than for purpose of resale.

For a period of twelve (12) months from the date of original delivery to Buyer, to Buyer's order, or to an Ohio Medical Authorized Dealer, this product, other than its expendable parts, is warranted to be free from functional defects in materials and workmanship and to conform to the description of the product contained in the operation manual and accompanying labels and/or inserts, provided that the same is properly operated under conditions of normal use, that regular periodic maintenance and service is performed and that replacements and repairs are made in accordance with the instructions provided. This same warranty is made for a period of sixty (60) days with respect to the expendable parts. The foregoing warranties shall not apply if the product has been repaired other than by Ohio Medical or in accordance with written instructions provided by Ohio Medical, or altered by anyone other than Ohio Medical, or if the product has been subject to abuse, misuse, negligence, or accident.

Ohio Medical's sole and exclusive obligation and Buyer's sole and exclusive remedy under the above warranties is limited to repairing or replacing, free of charge, at Ohio Medical's option, a product, which is telephonically reported to the nearest Ohio Medical Regional Service Office and which, if so advised by Ohio Medical, is thereafter returned with a statement of the observed deficiency, not later than seven (7) days after the expiration date of the applicable warranty, to the designated Ohio Medical Service Office during normal business hours, transportation charges prepaid, and which, upon Ohio Medical's examination, is found not to conform with the above warranties. Ohio Medical shall not be otherwise liable for any damages including, but not limited to incidental damages, consequential damages, or special damages.

There are no express or implied warranties which extend beyond the warranties herein above set forth. Ohio Medical makes no warranty of merchantability or fitness for a particular purpose with respect to the product or parts thereof.

General Warnings and Cautions

▲ WARNING

1. The MiniOX® 3000 Oxygen Monitor will perform to specifications only if it is used and serviced in accordance with the manufacturer's instructions. This instrument is to be used only by qualified, trained personnel who have carefully read the operating manual and labels and who have observed the information set forth. If this instrument does not perform as described in this manual, the instrument must not be used until the condition is rectified.
2. The MiniOX® 3000 Oxygen Monitor must be calibrated prior to each use. A two point calibration check must be performed weekly. *See Section 3, Operation.* If the instrument cannot be calibrated, the sensor must be replaced. If the instrument is still unable to be calibrated, the instrument must be serviced.
3. The oxygen sensor has a minimal response to certain gases other than oxygen. Be aware of these gases and their interference levels. *See Appendix C, Interferent Gases and Vapors.*
4. The oxygen sensor is affected by changes in barometric pressure. *See Appendix B, Effects of Pressure, Humidity and Temperature.*
5. The sensor is a sealed unit containing a potassium hydroxide electrolyte, which is caustic. If the sensor should develop a leak and the contents come in contact with skin or clothing, rinse area with large quantities of water. In case of eye contact, immediately flush eyes for at least 15 minutes, holding eyes open. Call a physician. Dispose of a leaking sensor immediately; it must be disposed of in accordance with all applicable federal, state, and local regulations.
6. Ensure a tight fit exists between the sensor and the tee adapter. Ohio Medical tee adapters are engineered to fit securely with Ohio Medical sensors. However, the sensor retaining strap must be used to prevent accidental separation of sensor and tee adapter.
7. Never operate the MiniOX® 3000 Oxygen Monitor if it is suspected that water or other liquids have entered into the case. If this occurs, immediately turn the unit OFF and contact your nearest Ohio Medical Service Center for additional information.
8. Use of devices generating or emitting electromagnetic radiation near the MiniOX® 3000 Oxygen Monitor may interfere with the proper operation of the product, causing it to fail to perform as designed. Particularly, the electromagnetic radiation from the interfering device may cause the product to display incorrect/erratic values or to stop operating. Special attention should be paid to the patient if this occurs.
9. Never use the MiniOX® 3000 Oxygen Monitor in combustible atmosphere, such as occurs with flammable anesthetics. Such use could result in ignition of atmosphere.
10. Never allow an excess length of cable near the patient's head or neck, as such could result in strangulation. Secure excess cable to the bed rail or other suitable object.

FAILURE TO COMPLY WITH THESE WARNINGS COULD JEOPARDIZE THE WELL-BEING OF THE PATIENT AND/OR HEALTH CARE PROFESSIONAL.

▲ CAUTION

1. Remove internal battery if unit is to be non-operational for extended periods of time.
2. Observe polarity when inserting a new battery. Incorrect connection may cause damage to the instrument.
3. The MiniOX® 3000 Oxygen Monitor must never be immersed in any cleaning solution, autoclaved, or exposed to temperatures greater than 70°C.
4. Use only genuine Ohio Medical Corporation accessories and replacement parts. Failure to do so may seriously impair the monitor's performance. Repair or alteration of the MiniOX® 3000 Oxygen Monitor beyond the scope of the maintenance instructions or by anyone other than an authorized Ohio Medical Corporation service person could cause the product to fail to perform as designed.
5. Improper mounting of the sensor in a breathing circuit may result in inaccurate readings. The sensor MUST be mounted with the deflector pointing downward to prevent moisture collection on the sensor membrane (see Figures 3-3 and 3-4 in *Section 3, Operation*). Install the sensor upstream from the humidifier to minimize its exposure to moisture.
6. Never use a MiniOX® 3000 Oxygen Monitor with a cable that appears worn, cracked, or has damaged insulation.

FAILURE TO COMPLY WITH THESE CAUTIONS COULD RESULT IN INSTRUMENT DAMAGE AND/OR FAILURE OF UNIT TO PERFORM TO SPECIFICATIONS.

Definition of Warnings and Cautions

▲ WARNING

Statement citing a potential safety hazard and possible injury to yourself or others.

▲ CAUTION

Statement citing a possibility of damage to the instrument or other property.

NOTE:

Advisory on instrument function.

Section 1**Introduction.....1-1**

General Description.....	1-1
Operating Principles.....	1-2
MiniOX® 3000 Oxygen Sensor	1-2
MiniOX® 3000 Instrument	1-2
Operator Interface	1-2
Internal Functions	1-2
Data and System Status	1-2
Performance Features	1-2
Calibration.....	1-2
Low/High Oxygen Concentration Alarms	1-3
Low Battery Alarms	1-3
Sensor Indicator	1-3
Calibration Needed Indicator	1-3
Error Handling	1-4
Test Functions.....	1-4
Radio Frequency/Electromagnetic Insensitivity.....	1-4

Section 2**Setting Up the MiniOX® 3000 Oxygen Monitor 2-1**

Figure 2-1 MiniOX® 3000 Oxygen Monitor	2-1
▲ CAUTION.....	2-2
Figure 2-2 Assembled MiniOX® 3000 Oxygen Monitor	2-2

Section 3**Operation.....3-1**

Calibration	3-1
▲ CAUTION	3-1
To Calibrate In Room Air, Figure 3-1	3-1
Figure 3-1 Calibrating the MiniOX® 3000 Oxygen Monitor in Room Air.....	3-1
To Calibrate at 100% O ₂ , Figure 3-2	3-2
Figure 3-2 Calibrating the MiniOX® 3000 Oxygen Monitor at 100% O ₂	3-2
Two-Point Linearity Check.....	3-3
Setting the Alarms.....	3-3
To Set the Low Alarm	3-3
To Set the High Alarm	3-4
Alarm Conditions.....	3-4
High and Low Oxygen Concentration Alarms	3-4
Silencing an Alarm	3-4
Low Battery Alarms.	3-4
Sensor Indicator.....	3-4
Error Handling.....	3-5
Table 3-1 Alarms and Status Messages	3-5
Test Functions.....	3-6
Battery Test.....	3-6
High and Low Alarms Test.	3-6
Installing the Sensor in a Breathing Circuit.	3-6

Mounting the Instrument with a Pole Bracket.....	3-6
Figure 3-3 Installing Sensor into Tee Adapter	3-7
Figure 3-4 Sensor in Breathing Circuit.....	3-8
Figure 3-5 MiniOX® 3000 Oxygen Monitor with Pole Mounting Bracket	3-8

Section 4

Maintenance and Care4-1

▲ CAUTION	4-1
Battery & Battery Cover Replacement	4-1
Figure 4-1. Battery Cover Removal	4-1
Sensor Replacement.....	4-2
Deflector Replacement.....	4-2
Cable Replacement.....	4-2
Cleaning, Disinfection and Sterilization.....	4-2
▲ CAUTION	4-2
Instrument	4-2
Sensor and Cable	4-3
Sensor Deflector, Retaining Strap and Tee Adapter	4-3

Appendix A

Specifications A-1

Table A-1. Specifications.....	A-1
--------------------------------	-----

Appendix B

Effects of Pressure, Humidity and Temperature B-1

▲ CAUTION	B-1
Effects of Pressure	B-1
▲ CAUTION	B-1
Effects of Humidity	B-1
Effects of Temperature	B-1
▲ CAUTION	B-1
▲ CAUTION	B-1

Appendix C

Interferent Gases and Vapors..... C-1

Table C-1 Interferent Gases and Vapors	C-1
--	-----

Appendix D

Troubleshooting D-1

Table D-1 Troubleshooting	D-1
---------------------------------	-----

Appendix E

Error Codes..... E-1

Table E-1 Error Codes	E-1
-----------------------------	-----

Appendix F

Accessories and Replacement PartsF-1

Table F-1 Accessories and Replacement Parts	F-1
---	-----

Section 1 Introduction

The MiniOX® 3000 Oxygen Monitor provides continuous, direct monitoring of oxygen mixtures in a variety of applications, including:

- Respiratory Therapy (e.g., respirators, ventilators, pediatric incubators)
- Anesthesiology (e.g., anesthesia machines)
- Oxygen Therapy (e.g., oxygen tents)

The monitor is for use by trained health care professionals:

- under the supervision, or on the order, of a physician
- in a hospital or clinical setting
- during emergency transport

General Description

Battery-operated and microprocessor-controlled, the MiniOX® 3000 Oxygen Monitor measures oxygen concentrations in the 0% to 100% range. The monitor's performance features ensure reliable and accurate oxygen measurement. These features include:

- calibration function
- high and low oxygen concentration alarms
- low and depleted battery alarms
- oxygen sensor indicator
- automatic error detection
- battery test
- oxygen alarm test

The calibration function allows calibration of the device against room air (defined as oxygen concentration of 20.8%) or 100% O₂. Audible and visual alarms alert the operator when monitor calibration is required.

High and low oxygen concentration alarms may be set in the ranges of:

- 16% to 100% (high alarm) and
- 15% to 99% (low alarm)

or the default high/low settings may be used (50% and 18%, respectively). Audible and visual alarms activate when oxygen concentrations:

- fall below the preset (or default) low alarm setting
- rise above the preset (or default) high alarm setting

The MiniOX® 3000 Oxygen Monitor:

- detects low and depleted battery conditions
- activates audible and visual alarms
- alarms for:
 - sensor disconnection or malfunction
 - various internal operating errors

The MiniOX® 3000 Oxygen Monitor conducts self-checks:

- at power-up (battery installation)
- at turn on
- during operation

Additionally, the monitor has two operator-initiated test functions:

- The Alarm Test verifies the operation of the high and low oxygen level alarms
- The Battery Test assesses the relative remaining battery life

The MiniOX® 3000 Oxygen Monitor consists of two components: the instrument and the oxygen sensor.

The front of the hand-held instrument features:

- a touch-sensitive keypad
- a liquid crystal display (LCD) that shows:
 - monitor status
 - continuous oxygen concentrations
 - preset alarm levels
- two red light-emitting diodes (LEDs) which serve as visual alarms

The back of the instrument case features:

- a bail bar to allow the instrument to “stand” on a horizontal surface during monitoring operations
- a plastic wedge that slides into an optional bracket for mounting the instrument on a horizontal or vertical pole

The galvanic oxygen sensor consists of a deflector assembly and a plastic housing containing two electrodes. A coiled cable connects the sensor to the

instrument. Plugs at each end of the cable snap into jacks (one located in the sensor housing and one located in the instrument) and are held securely in place by twist collars.

The oxygen sensor is introduced into a breathing circuit through an Ohio Medical Corporation tee adapter connecting two lengths of tubing. The sensor/tee adapter assembly is positioned with the sensor deflector pointing downward to ensure that moisture does not collect on the sensor membrane. The retaining strap ensures that the sensor remains securely in place in the tee adapter.

See the following appendices:

- *Appendix A, Specifications*
- *Appendix F, Accessories/Replacement Parts*

Operating Principles

MiniOX® 3000 Oxygen Sensor

The oxygen sensor includes two electrodes:

- a gold cathode exposed to the atmosphere through a fluoropolymer membrane
- a lead anode submerged in a potassium hydroxide solution

When oxygen diffuses through the membrane, the electrochemical reduction of oxygen on the cathode and the corresponding oxidation on the anode generate an electrical current proportional to the partial pressure of oxygen in the sample atmosphere. The instrument temperature compensates, amplifies, and converts the electrical current, displaying O₂ values.

The Ohio Medical Corporation oxygen sensor is self-zeroing; when no oxygen is present:

- no current is produced
- 0% oxygen is displayed

The sensor has a minimal response to gases other than oxygen (*see Appendix C, Interferent Gases and Vapors*).

MiniOX® 3000 Instrument

The MiniOX® 3000 Oxygen Monitor is battery-powered and microprocessor-controlled. The microprocessor:

- provides the operator interface
- controls internal functions
- monitors data and system status

Operator Interface

When the operator enters commands using the keypad, the microprocessor interprets these commands and responds by:

- displaying text in the LCD
- activating the LEDs
- emitting audible tones

Internal Functions

During operation, the microprocessor coordinates all internal functions including:

- self-testing
- response to keypad commands
- data collection
- display update
- confirmation that a programmed sequence is properly followed

Data and System Status

The signal from the oxygen sensor is amplified and converted to a digital value through electronic circuitry. Following software compensation, the microprocessor:

- compares current data to preselected values
- displays the updated O₂ concentration
- if appropriate, activates audible and visual alarms

The microprocessor also monitors internal systems, indicating such operating conditions as:

- calibration required
- low battery voltage
- sensor disconnect
- system error

Performance Features

Calibration

The MiniOX® 3000 Oxygen Monitor must be calibrated:

- daily, while in operation
- each time the monitor is turned ON
- following sensor disconnection/reconnection
- when environmental conditions (pressure, humidity and temperature) change

When a MiniOX® 3000 Oxygen Monitor with a sensor connected is turned ON, the monitor performs a self-test and a calibration requirement occurs:

- “CAL” flashes on the display, telling the operator to carry out the calibration procedure

The calibration procedure is initiated by exposing the sensor to a calibration gas [either room air (defined as oxygen concentration of 20.8%) or 100% oxygen] and pressing the corresponding key on the keypad. The following appears on the display:

- “CAL LOCKED”
- the selected calibration gas concentration.

When the **unlock** key is pressed the monitor displays:

- “CAL”
- a 10-segment bar graph which “counts down” two seconds per bar for 20 seconds

The monitor automatically calibrates to the selected concentration. At the end of the 20 seconds, the monitor:

- emits a beep indicating that calibration is complete
- enters the operating mode

See *Section 3, Calibration*

Low/High Oxygen Concentration Alarms

The MiniOX® 3000 Oxygen Monitor has audible and visual alarms that activate when oxygen concentrations exceed preset low or high alarm settings. Default settings are 18% and 50%, respectively; however, the operator may select alarm levels between 15% and 100%. See *Section 3, Setting the Alarms*

When the MiniOX® 3000 Oxygen Monitor detects an oxygen concentration that exceeds the preset alarm limit:

- the red LED for that alarm flashes

- an audible alarm activates
- the measured concentration appears in the display

The operator can silence the audible alarm for three 30-second intervals for a total of 90 seconds; however, the visual alarm continues to flash. At the end of the silence period, the audible alarm reactivates if the alarm condition is not corrected. See *Section 3, Silencing an Alarm*

Low Battery Alarms

The MiniOX® 3000 Oxygen Monitor features a two-stage battery alarm that warns of depleted and expired battery voltage:

- The first alarm alerts the operator that the monitor has approximately six hours of operating time remaining:
 - a warning message appears in the display
 - an audible alarm sounds at 30-second intervals
- If the operator does not replace the battery after this alarm, a second low battery alarm activates when the battery is no longer able to support monitoring. The monitor:
 - displays a warning message
 - activates an audible and visual alarm (See *Section 3, Low Battery Alarms*)

Sensor Indicator

During monitoring, the MiniOX® 3000 Oxygen Monitor displays a warning message; audible and visual alarms activate if:

- the oxygen sensor becomes disconnected
- the cable fails or disconnects from the sensor or instrument
- the sensor membrane is perforated
- the thermistor circuit opens

Calibration Needed Indicator

The MiniOX® 3000 Oxygen Monitor flashes “CAL”:

- when the monitor is turned ON
- following sensor disconnection/reconnection

If a calibration is performed using a calibration gas other than room air or 100% oxygen, or if the microprocessor detects a calibration error during normal operation:

- the display flashes a warning message: “CAL” and “ERR” five times; then, “CAL” flashes
- audible and visual alarms activate, alerting the operator that recalibration is required. See *Section 3, Calibration*

Error Handling

The MiniOX® 3000 Oxygen Monitor performs a self-test

- when it is turned ON
- after a battery is installed (power-up)
- during routine monitoring

If the microprocessor detects an error during these routine self-tests or during monitoring,

- the display flashes:
 - “ERR”
 - an error code
- audible and visual alarms activate
- the monitor ceases to operate until the appropriate service is performed. See *Appendix E, Error Codes*

To reset the monitor, press SET or turn the monitor OFF, then ON (press I/O twice). For further details, see *Appendix E, Error Codes*

Test Functions

In addition to alarms that alert the operator to low and expired battery voltage, the MiniOX® 3000 Oxygen Monitor features:

- a keypad function that allows the operator to check the relative battery life at any time. See *Section 3, Test Functions*
- a test function that allows the operator to ensure that the high and low alarms activate at the preset alarm levels. See *Section 3, Test Functions*

Radio Frequency/Electromagnetic Insensitivity

The MiniOX® 3000 Oxygen Monitor is designed to be insensitive to radio frequency interference (RFI) and electromagnetic interference (EMI). However, if the monitor comes in close contact with an RF transmitter or local electrical disturbance, an erratic reading may occur.

Section 2

Setting Up the MiniOX® 3000 Oxygen Monitor

The MiniOX® 3000 Oxygen Monitor is packaged in a shipping carton suitable for instrument storage. If there is obvious damage to the shipping carton or its contents, contact Ohio Medical Corporation Repair at:

866-549-6446, Option #1

To set up the monitor:

1. Verify that you have the following (see Figure 2-1):
 - MiniOX® 3000 Oxygen Monitor
 - Oxygen sensor and deflector in sealed package

- 10-foot coiled cable with twist collar
 - Tee adapter
 - Sensor retaining strap
 - 9-volt alkaline battery
 - MiniOX® 3000 Operation Manual CD
2. Check the sensor's manufacturing date on the sensor package. If the sensor is put into service within six months after this date, the sensor will meet performance specifications.
 3. Remove the sensor from the sealed package and attach it to the coiled cable.
 - a. Firmly press the connector until it snaps into place; tighten the twist collar.
 - b. Insert the opposite end of the coiled cable into the jack on the side panel of the instrument; tighten the twist collar.
 4. Remove the deflector from the package.

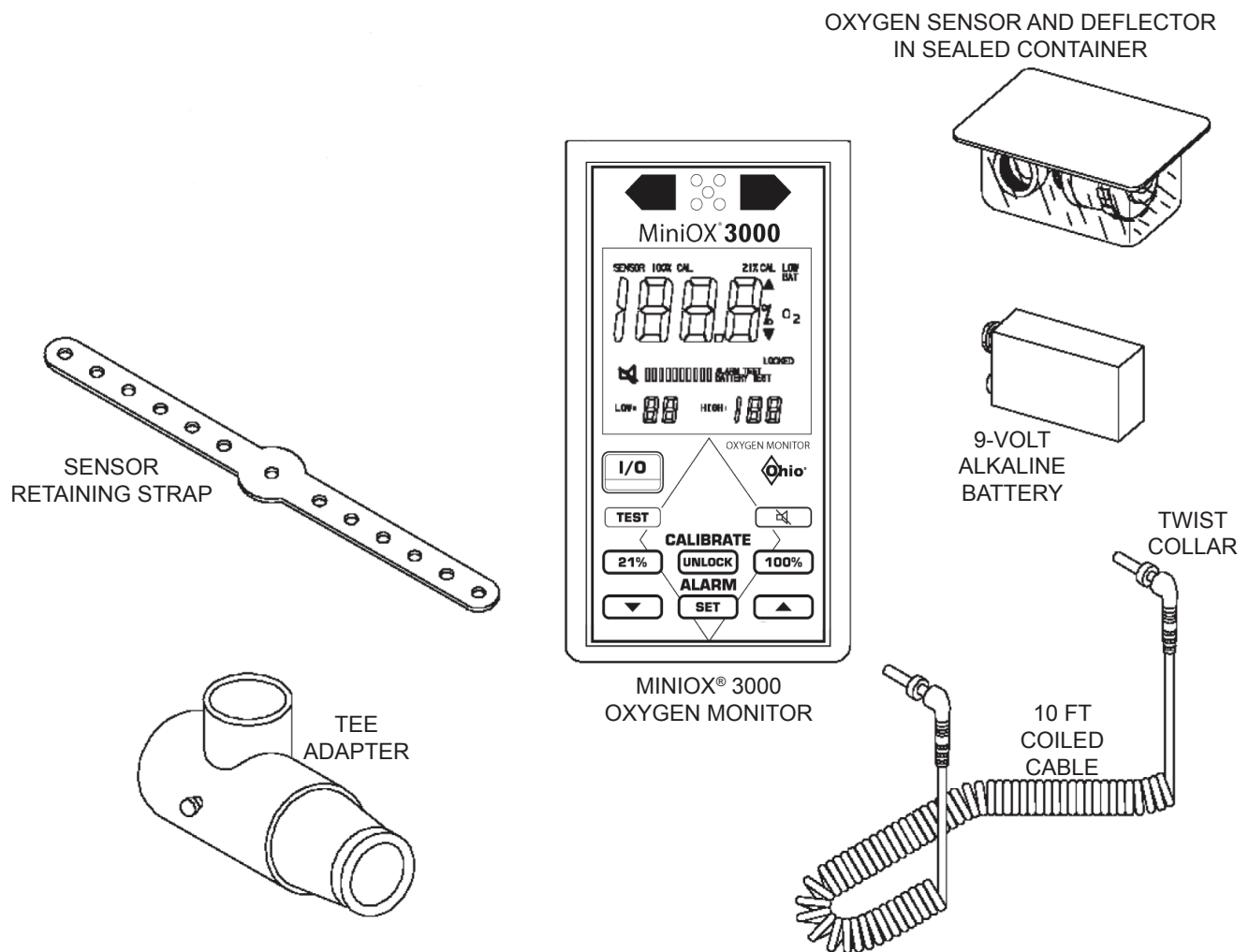

Figure 2-1
MiniOX® 3000 Oxygen Monitor

- a. Insert the gasket into the open end of the deflector, ensuring that the gasket is properly seated within the deflector
 - b. Gently screw the deflector onto the sensor (For monitoring in a breathing circuit, see *Section 3, Installing the Sensor in a Breathing Circuit*)
5. Unscrew the two battery cover screws on the back of the instrument.
- a. Remove the cover
 - b. Install the battery (See *Section 4, Battery Replacement* for full battery installation instructions)

After battery installation:

- the display flashes
- the instrument performs a self-test
- then turns OFF

6. Proceed to *Section 3, Operation*

▲ CAUTION

Do not handle the sensor unnecessarily during calibration or use. Body heat can cause the sensor's thermistor to change disproportionately to the change in gas sample temperature at the sensing electrode. This can produce some error until thermal equilibrium is restored.

See *Appendix F, Accessories/Replacement Parts* for ordering MiniOX® 3000 Monitor accessories and replacement parts (Figure 2-2).

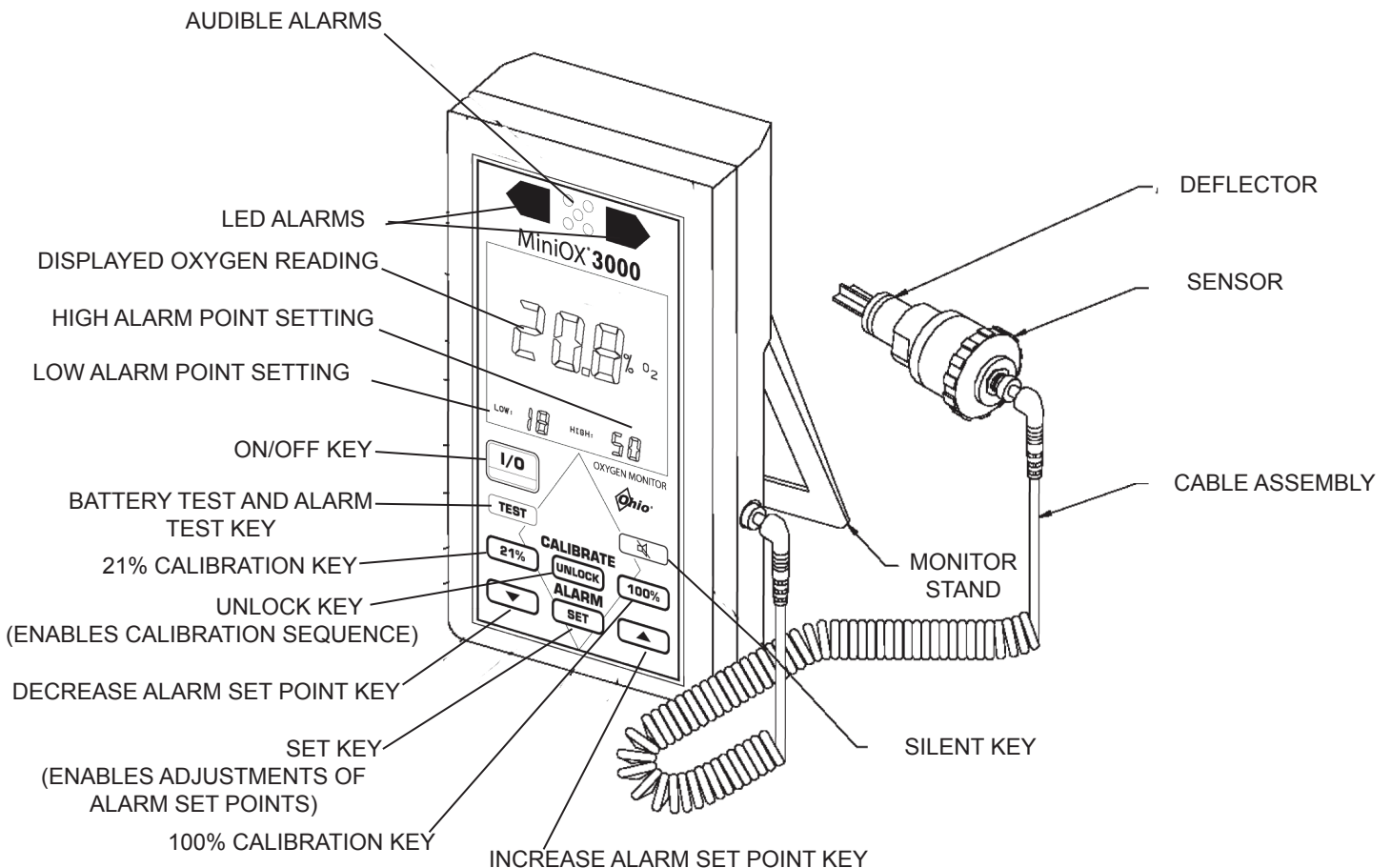

Figure 2-2
Assembled MiniOX® 3000 Oxygen Monitor

Section 3 Operation

This section describes the following operational procedures and functions of the MiniOX® 3000 Oxygen Monitor:

- Calibration
- Two-Point Linearity Check
- Setting the Alarms
- Alarm Conditions
- Silencing an Alarm
- Test Functions
- Installing the Sensor in a Breathing Circuit
- Mounting the Instrument with a Bracket

Calibration

The MiniOX® 3000 Oxygen Monitor requires calibration:

- daily, while in operation

- when the operating environment changes
- after the monitor is turned ON
- if the sensor is disconnected and reconnected to the instrument

Recommended practice of calibration is against room air (defined as oxygen concentration of 20.8%). When a more precise measurement is desired, repeat calibration using 100% oxygen concentration. Changes in pressure, humidity or temperature may affect calibration accuracy (see *Appendix B, Effects of Pressure, Humidity, and Temperature*).

⚠ CAUTION

Do not handle the sensor unnecessarily during calibration or use. Body heat can cause the sensor's thermistor to change disproportionately to the change in gas sample temperature at the sensing electrode. This can produce some error until thermal equilibrium is restored.

To Calibrate In Room Air (Figure 3-1):

1. Expose sensor to room air.

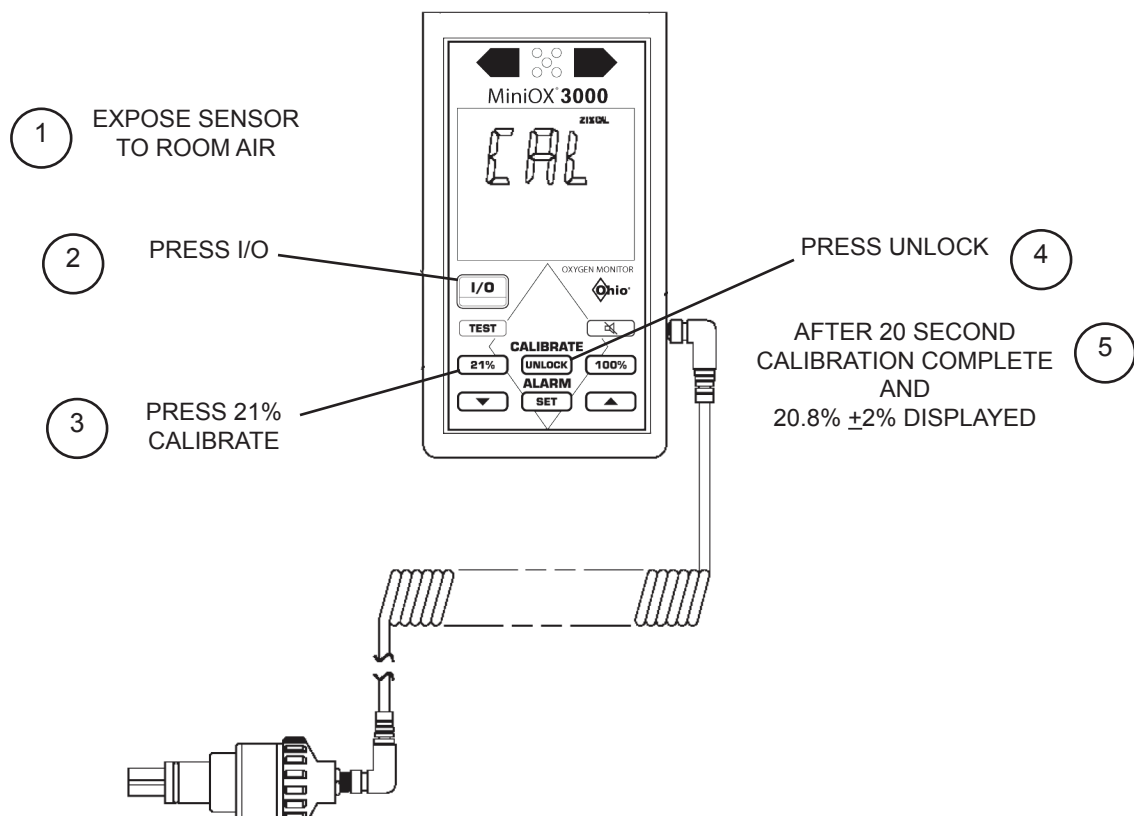

Figure 3-1
Calibrating the MiniOX® 3000 Oxygen Monitor in Room Air

2. Press I/O to turn ON the instrument.
 - “CAL” flashes in the display
 3. Press 21%. The following appears on the display:
 - “CAL”
 - “LOCKED”
 - “21% CAL”
 4. Press UNLOCK. The following appears:
 - “CAL”
 - “21% CAL”
 - a 10-segment bar graph that “counts down” two seconds per bar for 20 seconds
 5. After 20 seconds, the calibration process is complete the device:
 - displays $20.8\% \pm 2\% \text{ O}_2$ (18.8% to 22.8%)
 - proceeds to the monitoring mode
 - displays the current oxygen concentration as $\% \text{ O}_2$
1. Calibrate in room air (see Section 3, To Calibrate in Room Air)
 2. Expose the sensor to 100% oxygen and allow the readings to stabilize prior to initiating the calibration.
 - “CAL” flashes in the display.
 3. Press 100%. The following appears on the display:
 - “CAL”
 - “LOCKED”
 - “100% CAL”
 4. Press UNLOCK. The following appears on the display:
 - “CAL”
 - “100% CAL”
 - a 10-segment bar graph that “counts down” two seconds per bar for 20 seconds.
 5. After 20 seconds, the calibration process is complete; the device:
 - displays $100.0\% +0/-2\%$ (98% to 100%)
 - proceeds to the monitoring mode
 - displays the current oxygen concentration as $\% \text{ O}_2$

To Calibrate at 100% O₂ (Figure 3-2)

Note: Prior to calibrating at 100% O₂, the MiniOX® 3000 Oxygen Monitor must first be calibrated in room air.

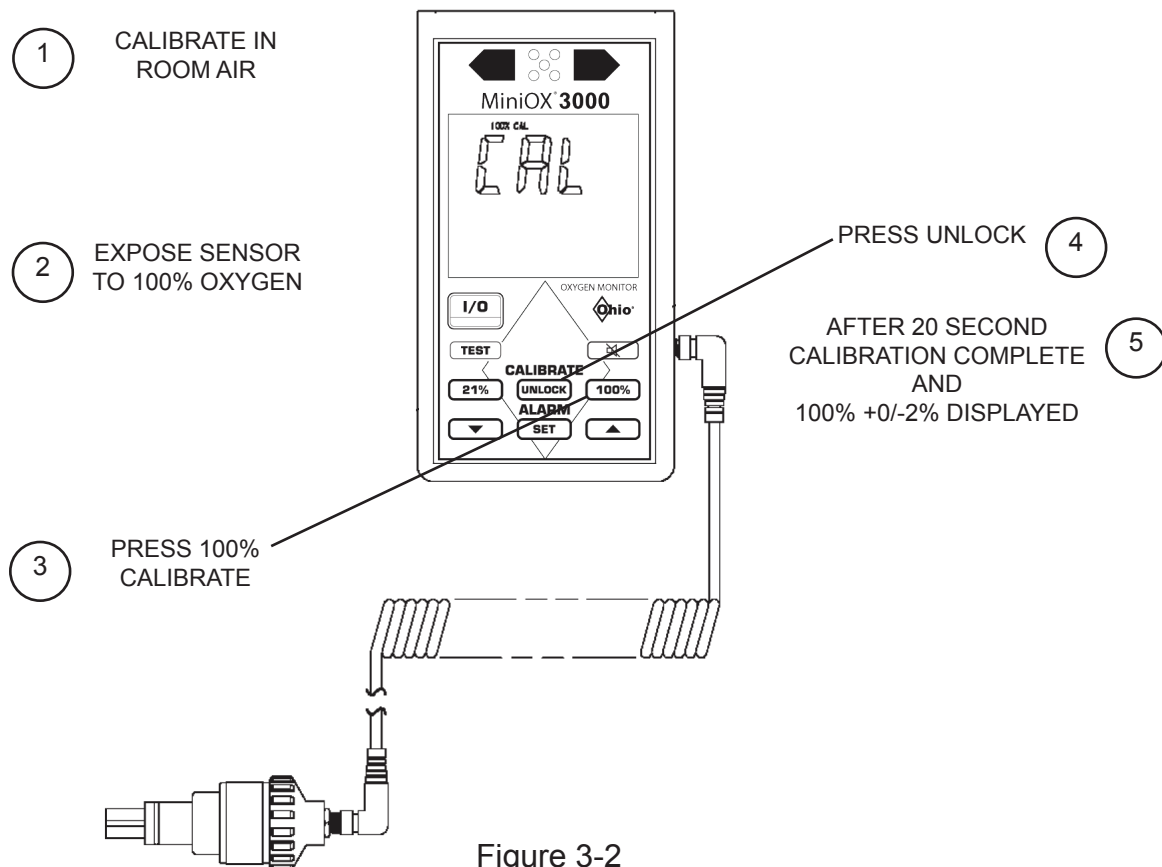

Figure 3-2
Calibrating the MiniOX® 3000 Oxygen Monitor at 100% O₂

NOTE: The MiniOX® 3000 Oxygen Monitor has a five second “time out” following keypad functions. If you do not press UNLOCK within five seconds, the instrument returns to the flashing “CAL” mode.

NOTE: During operation if “CAL ERR” flashes in the display, visual, audible alarms activate, and then “CAL” flashes, turn OFF the instrument and repeat calibration procedure. When recalibrating, be sure to select the calibration value and use the corresponding calibration gas. If “CAL ERR” reoccurs, it may be necessary to replace the sensor. (See Section 4, “Sensor Replacement”)

NOTE: During operation if “CAL” displays, you must recalibrate the monitor. If “CAL” displays following proper recalibration, it may be necessary to replace the sensor. (See Section 4, Sensor Replacement)

Two-Point Linearity Check

To evaluate sensor performance, conduct a two-point linearity check on the monitor every week or any time you suspect that the sensor is not accurately reading oxygen concentrations. Acceptable range for room air measurement during a linearity check is:

- 20.8% \pm 2% (18.8% to 22.8%). This variation allows for differences in:
 - sampling methods
 - accuracy of gas concentration
 - precision of initial setting

If linearity deviates more than \pm 2%, the sensor is nearing end-of-life and should be replaced.

To perform a two-point linearity check:

1. Calibrate in room air.
2. Place the sensor in a stream of oxygen with a known concentration of 100% until the reading stabilizes.
3. Recalibrate the monitor.
4. After calibration, measure room air. This reading should be 20.8% \pm 2% (18.8% or 22.8%) within five minutes.
 - If the variation is greater than \pm 2%, repeat the

two-point linearity check

- If the variation is still greater than \pm 2%, replace the sensor. (See Section 4, Sensor Replacement)

Setting the Alarms

The default Alarm Set points are:

- 18% for Low Alarm (appears in the lower left corner of the display)
- 50% for High Alarm (appears in the lower right corner of the display)

These alarm points can be reset between 15% and 100%.

NOTE: The MiniOX® 3000 Oxygen Monitor retains current alarm settings when turned OFF, if the alarm settings are not below 18%. However, if the alarm settings are lower than 18% when the MiniOX® 3000 Oxygen Monitor is turned OFF or following battery replacement, alarm set points return to the default settings of 18% and 50%.

To Set the Low Alarm

1. Press SET once. The following appears on the display:
 - “AL”
 - up/down arrows
2. Using the arrow keys, scroll up or down to the desired Low Alarm set point (15% to 99%).
3. The MiniOX® 3000 Oxygen Monitor “locks” this value. After five seconds, the monitor:
 - beeps once
 - automatically proceeds to the Monitoring Mode

NOTE: The Low Alarm CANNOT be disabled or set:

- below 15%
- above 99%
- higher than or equal to the High Alarm setting

To Set the High Alarm

1. Press SET twice. The following appears on the display:

- “AL”
 - up/down arrows
2. Using the arrow keys, scroll up or down to the desired High Alarm set point (16% to 100%).
 3. The MiniOX® 3000 Oxygen Monitor “locks” this value. After five seconds, the monitor:
 - beeps once
 - automatically proceeds to Monitoring Mode (Press SET once after Step 2 to manually proceed to Monitoring Mode)

NOTE: The HIGH Alarm value:

- CANNOT be set equal to, or less than, the Low Alarm value
- CAN be disabled by increasing the alarm set point beyond 100% until “--” displays

Alarm Conditions**High and Low Oxygen Concentration Alarms**

When the MiniOX® 3000 Oxygen Monitor detects an oxygen concentration that exceeds the preset alarm limit:

- the red LED flashes for that alarm (High or Low)
- an audible alarm activates
- the measured concentration displays

Silencing an Alarm

The MiniOX® 3000 Oxygen Monitor features a silence function that allows the operator to temporarily mute the O₂ concentration audible alarm.

1. When an audible alarm activates, press the silent key (labeled with a horn icon) to mute the alarm for up to three 30-second intervals, press:
 - once for a 30-second interval
 - twice (within two seconds) for a 60-second interval
 - three times (within four seconds) for a 90-second interval

The following appears on the display:

- a horn icon
- a three-bar graph showing a “countdown” of 10 seconds per bar for each 30 second interval

NOTE: When the audible alarm is silenced, the appropriate visual alarm continues to flash.

If the alarm condition is not corrected within the preset silence interval (30,60, or 90 seconds):

- the audible alarm reactivates

If the alarm condition is corrected and then reoccurs within this interval:

- both audible and visual alarms activate

2. To manually terminate the silence mode, press the down arrow (labeled with a ▼ icon).

Low Battery Alarms

The MiniOX® 3000 Oxygen Monitor features a two-stage battery alarm that warns of depleted and expired battery voltage:

- The first alarm alerts the operator that the monitor has approximately six hours of operating time remaining:
 - “LOW BAT” appears on the display
 - an audible alarm sounds at 30-second intervals
- If the operator does not replace the battery after this alarm, a second low battery alarm activates when the battery is no longer able to support monitoring.
 - the monitor displays “LOW BAT” and “---”
 - audible and visual alarms are activated

For periodic checks on battery status, see *Section 3, Test Functions*”

Sensor Indicator

During monitoring, the MiniOX® 3000 Oxygen Monitor displays “SENSOR” and “OFF”; audible and visual alarms activate if:

- the oxygen sensor becomes disconnected
- the cable fails or disconnects from the sensor or instrument
- the sensor membrane is perforated
- the thermistor circuit opens

Error Handling

The MiniOX® 3000 Oxygen Monitor performs a self-test

- when it is turned ON
- after a battery is installed

If the microprocessor detects an error during these routine self-tests or during monitoring:

- the display flashes “ERR” and an error code
- audible and visual alarms activate
- the monitor ceases to operate until the appropriate service is performed; to reset the

monitor, press SET or turn the monitor OFF, then ON (press I/O twice). For further details see Appendix E, Error Codes

NOTE: During normal operation, if a key is pressed and held longer than nine seconds, audible and visual alarms activate.

1. To reset the monitor, press SET or turn the monitor OFF, then ON (Press I/O twice). For further details see *Appendix E, Error Codes*

Table 3-1 is a summary of MiniOX® 3000 Oxygen Monitor alarms and status messages.

Table 3-1 Alarms and Status Messages

ALARM	CAUSE	CORRECTIVE ACTION
Low O ₂ alarm: O ₂ concentration appears, visual alarm flashes, and audible alarm activates	Oxygen concentration is below the preset Low Alarm setting	Check patient and delivered oxygen concentration
		Verify that low alarm setting is appropriate
High O ₂ Alarm: O ₂ concentration appears, visual alarm flashes, and audible alarm activates	Oxygen concentration is above the present High Alarm setting	Check patient and delivered oxygen concentration
		Verify that high alarm setting is appropriate
“SENSOR OFF” displays; visual and audible alarms activate	Cable is disconnected or malfunctioning	Check cable and sensor connections
	Sensor is disconnected	Visually check cable for damage. If necessary, replace cable
	Sensor membrane is perforated	If the alert persists, replace sensor
	Thermistor circuit is open on the sensor circuit board	If alert persists following sensor replacement, call Ohio Medical Corporation service
During calibration, “CAL ERR” flashes, visual and audible alarms activate; then “CAL” flashes	Calibration performed using a gas other than room air or 100% oxygen or wrong calibration key pressed (100%/21%)	Recalibrate the monitor, ensure proper calibration key pressed for calibration gas of room air or 100% oxygen
		If the alert persists, replace sensor
		If alert persists following sensor replacement, call Ohio Medical Corporation service
During calibration, “CAL” flashes	Sensor signal is out of monitoring range	Recalibrate the monitor, ensure proper calibration key pressed for calibration gas of room air or 100% oxygen
		If the alert persists, replace the sensor
		If alert persists following sensor replacement, call Ohio Medical Corporation service
“LOW BAT” displays and monitor beeps every 30 seconds	Monitor has approximately six hours of operating time remaining	Replace the battery as soon as possible; then, recalibrate the monitor and reset the high and low alarm values
“LOW BAT” displays “---” flashes, both visual alarms activate, and monitor emits a three-tone beep for four minutes; monitor shuts OFF	Battery is expired and monitor is not operating	Replace the battery as soon as possible; then recalibrate the monitor and reset the high and low alarm values
“ERR” and error code (01 to 08) display, visual and audible alarms activate and monitor locks	Microprocessor detects internal error	Note error code and see <i>Appendix E, Error Codes</i>
		Disconnect Battery
		Call Ohio Medical Corporation Service

Test Functions

Battery Test

In addition to alarms alerting the operator to low and expired battery voltage, the MiniOX® 3000 Oxygen Monitor features a keypad function allowing the operator to check the relative battery life at any time. To test battery status:

1. Press TEST once. The following appears on the display:
 - “BATTERY TEST”
 - a 10-bar graph showing relative battery life. Ten bars indicate a fully charged battery; one bar indicates a battery near depletion
2. After five seconds, the MiniOX® 3000 Oxygen Monitor proceeds to the Monitoring mode, displaying oxygen concentrations as %O₂.

High and Low Alarms Test

The MiniOX® 3000 Oxygen Monitor features a test function to ensure that the high and low alarms activate at the preset alarm levels. To test the alarms:

Press TEST twice.

- “ALARM TEST” displays
- the instrument automatically scrolls up to the high alarm value and flashes this value on the display
- the audible alarm and visual high alarm activate (If the high alarm value is disabled, the instrument scrolls down from 100% to the low alarm value)
- the instrument then automatically scrolls down to the low alarm value and flashes this value on the display
- the audible alarm and visual low alarm activate
- the MiniOX® 3000 Oxygen Monitor proceeds to the Monitoring Mode, displaying oxygen concentrations as %O₂

NOTE: The MiniOX® 3000 Oxygen Monitor is not monitoring during the Alarm Test which may take up to 30 seconds to complete.

NOTE: The Alarm Test will not function if the MiniOX® 3000 Oxygen Monitor is in an alarm condition.

Installing the Sensor in a Breathing Circuit

To use the sensor in a breathing circuit, you will need the following:

- Sensor (with deflector)
- Tee adapter
- Retaining Strap

To install the sensor in a breathing circuit:

1. Install the tee adapter into the breathing circuit upstream from the humidifier. Make sure that side port of the tee adapter is facing upward.
2. Remove the coiled cable from the sensor.
3. Firmly insert the sensor (with deflector) into the tee adapter with the deflector pointing downward (Figure 3-3) to prevent moisture from condensing onto the sensor membrane (*See Appendix B, Effects of Pressure, Humidity, and Temperature*). Make sure that the sensor fits tightly into the tee adapter.
4. Install one end of the retaining strap over a post on the side of the tee adapter.
5. Loop the strap over the sensor, inserting the strap center hole over the sensor cable jack.
6. Install the other end of the strap over the other tee adapter post.
7. Re-attach the coiled cable to the sensor. Tighten the twist collar.

The sensor is securely placed for monitors (See Figure 3-4).

Mounting the Instrument with a Pole Bracket

The MiniOX® 3000 Oxygen Monitor (as shown in Figure 3-5) can be attached to a vertical or horizontal pole using the Ohio Medical Corporation Mounting Bracket (*See Appendix F, Accessories/Replacement Parts*). To mount the MiniOX® 3000 Oxygen Monitor:

1. Configure the bracket for either horizontal or vertical attachment by adjusting the dovetail mounting plate on the bracket.
2. Slide the mounting bracket onto the pole; secure by tightening the screw knob.
3. Slide the wedge on the back of the monitor into the dovetail mounting plate.

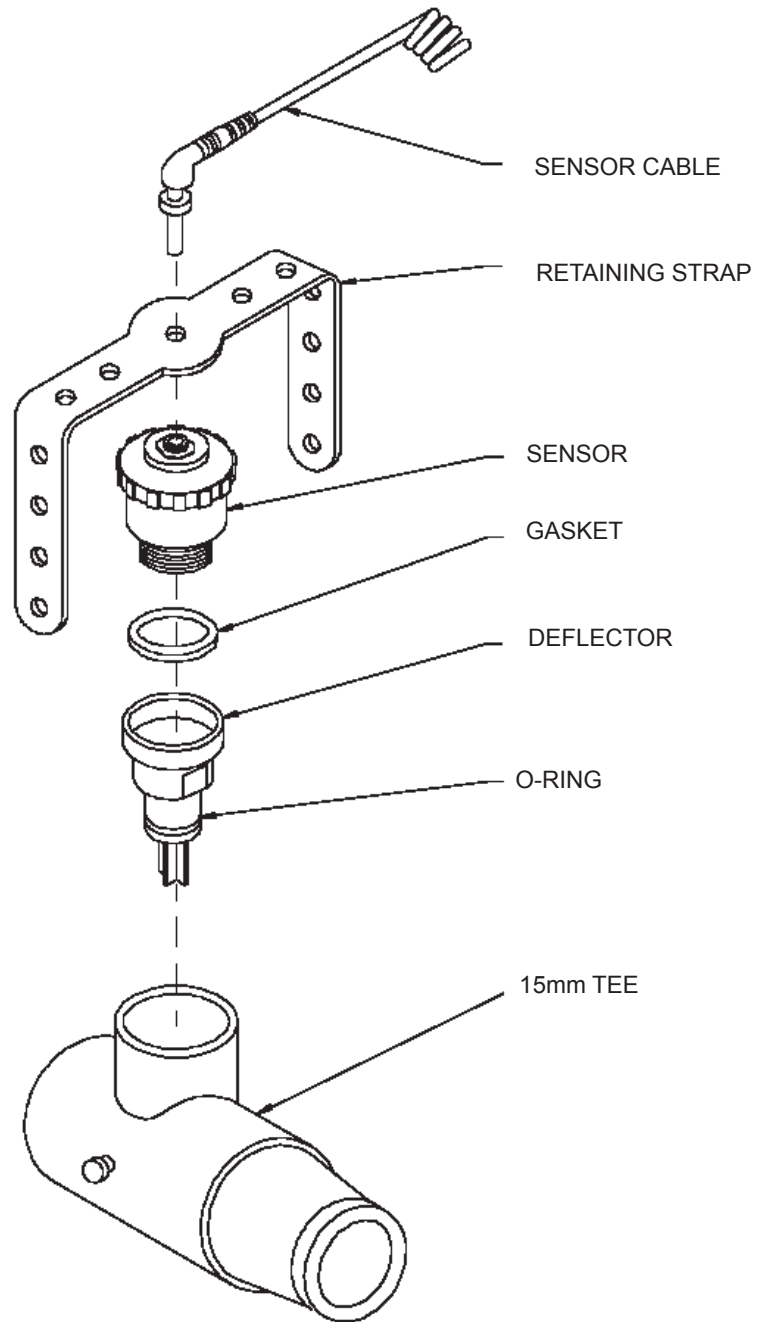

Figure 3-3
Installing Sensor into Tee Adapter

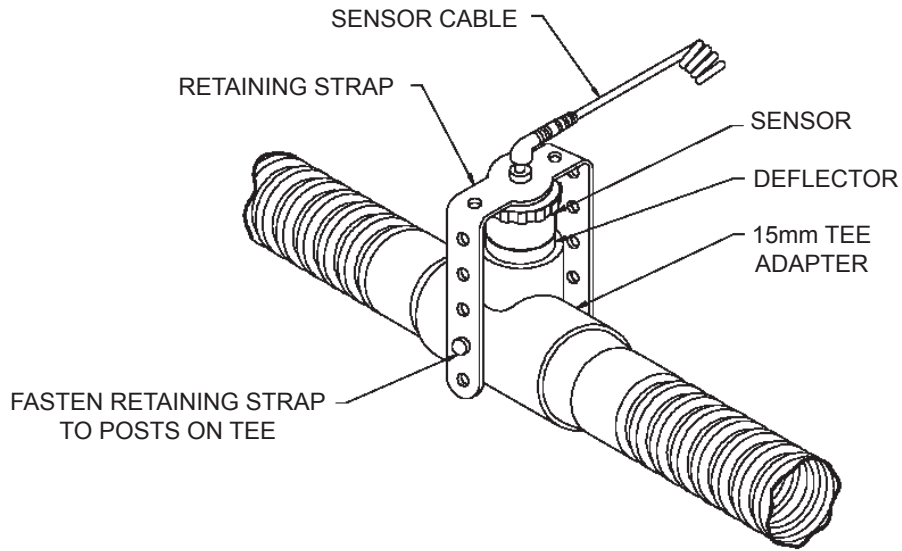

Figure 3-4
Sensor in Breathing Circuit

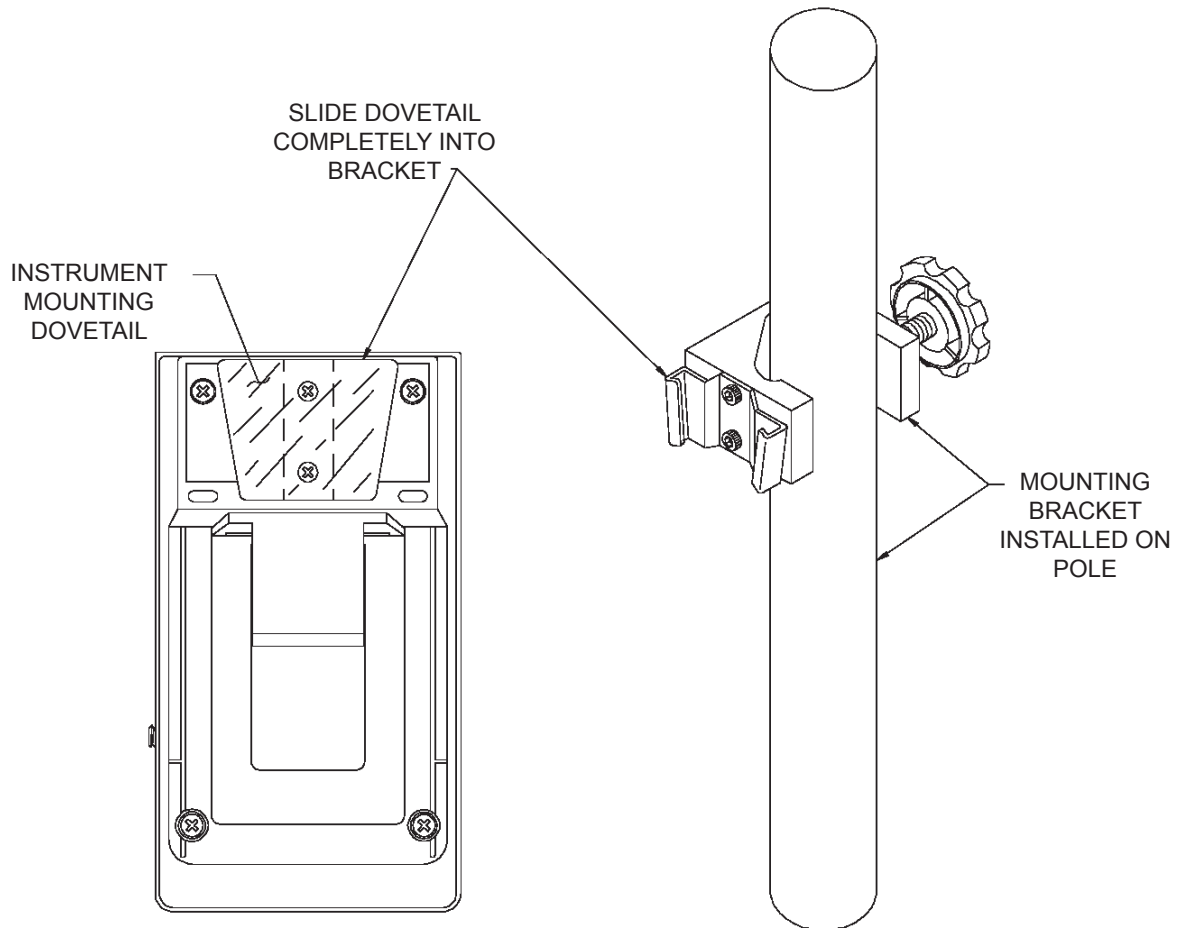

Figure 3-5
MiniOX® 3000 Oxygen Monitor with Pole Mounting Bracket

Section 4 Maintenance and Care

▲ WARNING

Use only genuine Ohio Medical Corporation replacement parts when performing any maintenance procedures included in this manual. Failure to do so may seriously impair the monitor's performance. Repair or alteration of the MiniOX® 3000 Oxygen Monitor beyond the scope of the maintenance instructions or by anyone other than an authorized Ohio Medical Corporation service person could cause the product to fail to perform as designed.

This section describes the following general maintenance and care procedures for the MiniOX® 3000 Oxygen Monitor:

- Battery Replacement
- Sensor Replacement
- Deflector Replacement
- Cable Replacement
- Cleaning

Battery & Battery Cover Replacement

The MiniOX® 3000 Oxygen Monitor requires one

standard 9-volt alkaline battery. To replace the battery:

1. Verify that the monitor is turned OFF. The display should be blank.
2. Pull out the support stand from the back of the case.
3. Unscrew the two screws on the battery cover in the back of the instrument and remove cover. See Figure 4-1.
4. Remove the battery from the case and unsnap the battery from the battery holder.

NOTE: To ensure proper start-up, wait at least 45 seconds before connecting the fresh battery to the battery connector.

5. Snap the terminal of the new battery into the battery holder.
6. Install the battery cover and screw into place. Make sure that the battery cover is properly seated and flat on the back of the MiniOX® 3000 Oxygen Monitor case.
7. Recalibrate the monitor. Reset the low and high alarms, if desired.

NOTE: To maximize battery life, press I/O to turn OFF the MiniOX® 3000 Oxygen Monitor when not monitoring. In order to retain alarm settings, do not remove battery .

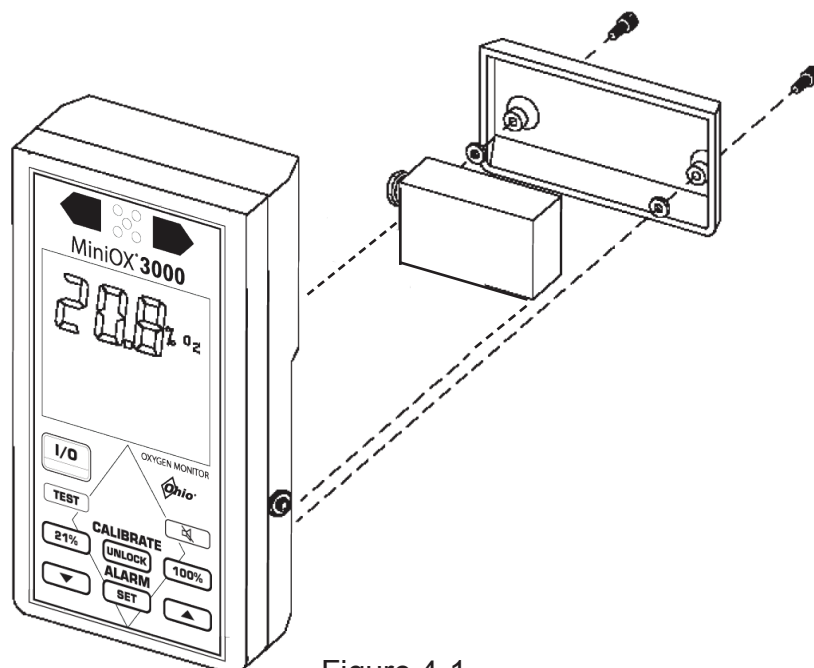

Figure 4-1
Battery Cover Removal

Sensor Replacement

To ensure safe and effective use of your device, the sensor must be replaced with a MiniOX® sensor as this sensor is manufactured for this instrument. Use of other types of sensors has not been tested and is not endorsed by Ohio Medical Corporation. Use of other sensor types will void your warranty.

There are no serviceable parts in the sensor or cable assemblies, the entire unit must be replaced.

Replace the sensor when:

- Room air reading is greater than 20.8% \pm 2% (18.8% to 22.8%) in Two-Point Linearity Check
- The MiniOX® 3000 Oxygen Monitor will not calibrate.
- “Sensor” and “OFF” display and audible and visual alarms persist when sensor and cable connections are correct and cable is viable.

To replace the sensor:

1. Verify that the monitor is turned OFF. The display should be blank.
2. Disconnect the expired sensor from the coiled cable.
3. Attach a new sensor to the coiled cable and firmly press the connector until the sensor snaps into place. Tighten the twist collar.
4. Recalibrate the monitor.

Deflector Replacement

To replace the deflector:

1. Gently unscrew the old deflector and remove the gasket.
2. Insert a new gasket into the large end of the new deflector. Carefully screw the new deflector onto the sensor, making sure that the new gasket is properly seated.

See Figure 3-3 for proper sensor and deflector assembly.

Cable Replacement

To replace the coiled cable:

1. Verify that the monitor is turned OFF. The display should be blank.
2. Disconnect the old cable from the sensor.
3. Disconnect the old cable from the instrument.
4. Attach the new cable to the sensor. Firmly press the connector until the sensor snaps into place. Tighten the twist collar.
5. Attach the new cable to the instrument. Firmly press the connector until it snaps into place. Tighten the twist collar.
6. Recalibrate the instrument.

Cleaning, Disinfection and Sterilization

⚠ CAUTION

Never autoclave, immerse, or expose the MiniOX® 3000 Oxygen Monitor (including sensor) to high temperatures (>70°C). Never expose the device to pressure, irradiation, vacuum, steam, or chemicals (other than alcohol or mild cleaning agents).

Clean the instrument and sensor by wiping with a cloth lightly dampened with Isopropyl Alcohol or mild detergent. Make sure that no moisture seeps into the instrument case or cable jack port.

Instrument

When cleaning or disinfecting the instrument, care must be taken to prevent entry of solutions into the instrument case. If it is suspected that solutions or moisture enters the case, verify performance by conducting a self-test (*see Possible physical damage to instrument, Appendix D*).

Cleaning

The external surfaces of the unit may be cleaned by wiping them with a cloth moistened with a mild detergent solution.

Disinfection

The external surfaces of the unit may be disinfected by wiping them with a cloth moistened with ethanol or Cidex. The instrument is not designed to withstand the conditions imposed by steam, ethylene oxide or radiation sterilization.

Sensor and Cable***Cleaning***

The external surfaces of the oxygen sensor and of the cable may be cleaned by wiping them with a cloth moistened with a mild detergent solution.

Disinfection

The external surfaces of the oxygen sensor housing and of the cable may be disinfected by wiping them with a cloth moistened with ethanol or Cidex. The instrument is not designed to withstand the conditions imposed by steam, ethylene oxide or radiation sterilization.

Sensor Deflector, Retaining Strap and Tee Adapter***Cleaning***

The sensor deflector, retaining strap and tee adapter may be cleaned by wiping them with a cloth moistened with a mild detergent solution. The parts must be thoroughly dry before they are used.

Disinfection

The sensor deflector, retaining strap and tee adapter may be disinfected by washing them with ethanol or Cidex (per manufacturer's instructions). The parts must be thoroughly dry before they are used.

Sterilization

The sensor deflector, retaining strap and tee adapter may be sterilized using Cidex (per manufacturer's instructions), steam or ethylene oxide. Due to the varying conditions imposed on materials during sterilization, it is not possible to determine the exact number of times sterilization processes can be carried out. Therefore, the operator must carefully examine the sensor deflector, retaining strap and tee adapter after sterilization and prior to use to verify that the item is fit for use. The operator must verify that the items are free from tears and cracks and that the items have not undergone any material changes that may compromise their fitness for use (e.g., brittleness and dimensional changes). The operator must also examine the items to verify that the items are free of chemical residuals resulting from the sterilization process.

Because of the variability of cleaning, disinfection and sterilization processes, Ohio Medical Corporation cannot provide specific sterilization instructions, nor can the sterility of an item be ensured.

Appendix A Specifications

Table A-1. Specifications		
O₂ ALARM SYSTEM	LOW/HIGH O ₂ ALARM	Pulsating alarm, flashing LEDs
ACCURACY		± 1% of full scale (RTP*) as calibrated in the environment of use (total accuracy, including linearity, is 2%)
LINEARITY		±1% of full scale (RTP*)
NOMINAL RESPONSE TIME (O ₂ directed at sensor at 2 liters per minute at RTP)		90% in 20 seconds
		97% in 30 seconds
SENSOR LIFE		Over one year in normal medical conditions (nominal 750,000 O ₂ hours)
SENSOR SHELF LIFE		Six months minimum (stored in sealed package)
BATTERY LIFE		Approximately 1500 device hours, assuming 80% ON, 20% OFF
OPERATING TEMPERATURE RANGE		0°C to 40°C (32°F to 104°F)
STORAGE TEMPERATURE		-40°C to 70°C (-40°F to 158°F)
HUMIDITY		5% to 95% RH (non-condensing)
DIMENSIONS	INSTRUMENT	5.98" X 3.26" X 1.31"
	SENSOR	1-1/5" OD x 1-3/4" long
WEIGHT	INSTRUMENT	260 g (9.2 oz)
	SENSOR	35 g (1.25 oz)
BATTERY ALARM SYSTEM	STAGE 1	Warning that approximately six hours of monitoring life remain; LOW BAT appears on display; beep sounds every 30 seconds until battery is replaced or Stage 2 occurs.
	STAGE 2	Alarm that proper operation is not assured; monitor shuts down, audible and visual alarms are activated.
*RTP: Room temperature and pressure, e.g., 23°C ± 3° and ambient barometric pressure		

Appendix B

Effects of Pressure, Humidity and Temperature

⚠ CAUTION

To ensure accurate and reliable oxygen monitoring, it is necessary to have a thorough understanding of the effects of pressure, humidity, and temperature on the sensor.

Effects of Pressure

The sensor responds to partial pressure (not percentage) of oxygen. Changes in barometric pressure change the reading, even if the percent of oxygen in the sample remains constant.

Partial pressure of oxygen (PO_2) equals the percent of oxygen (% O_2) times the pressure at which the sample is measured (mmHg).

$$PO_2 = (\%O_2) (mmHg)$$

For example: at sea level, the pressure equals 760 mmHg and dry air contains 21% O_2 . Therefore:

$$PO_2 = (21\%) (760 \text{ mmHg})$$

$$PO_2 = 160 \text{ mmHg}$$

If you calibrate an instrument to read 21% at 760 mmHg partial pressure and then take the instrument to an area above sea level, a lower reading occurs due to a lower partial pressure. For a pressure of 700 mmHg:

$$PO_2 = (21\%) (700 \text{ mmHg})$$

$$PO_2 = 147 \text{ mmHg}$$

The percent reading on the instrument is derived from the following formula:

$$PO_2 \text{ Actual} = 147 \text{ mmHg}$$

$$PO_2 \text{ Sea level} = 160 \text{ mmHg}$$

When PO_2 sea level is 21%

$$(21\%) (147 \text{ mmHg})$$

$$PO_2 \text{ Actual} = (147 \text{ mmHg}) = 19.3\%$$

Therefore, to eliminate error due to pressure changes, the instrument must be calibrated at the pressure in which it is used.

⚠ CAUTION

Do not expose the sensor to pressure outside the range of 600 to 900 mmHg (23.62 to 35.43 Inches Hg), as this may cause inaccuracies.

Effects of Humidity

The presence of humidity in an oxygen sample decreases the actual concentration of oxygen. Humidity in a sample has the same effect as diluting the sample with another gas. For example, if 100% oxygen is saturated with 100% humidity, the actual concentration of oxygen drops to 96% - 97%.

As with all oxygen gas sensors, condensation on the sensor membrane blocks the flow of oxygen, resulting in a lower oxygen concentration reading and an increased response time. This is a typical problem resulting from locating the sensor downstream from the humidifier in an oxygen delivery system; clearing the sensor face and deflector restores normal operation. However, to avoid this problem when using the sensor in a breathing circuit, position the sensor upstream of the humidifier and mount the sensor with the deflector pointing downward to prevent moisture from draining onto the sensor membrane.

Effects of Temperature

Due to an internal thermistor (temperature variable resistor), the MiniOX® 3000 sensor is minimally affected by temperature change. Variations in the sensor reading from temperature change are less than 3% when the instrument is calibrated and used in a monitoring environment of 0°C to 40°C (32°F to 104°F).

Operating Temperature Range:
0° to 40°C (32° to 104°F)

⚠ CAUTION

Do not use instrument outside operating temperature range.

⚠ CAUTION

Do not handle the sensor more than necessary during calibration or use. Body heat can cause the sensor's thermistor to change disproportional to the change in gas sample temperature at the sensing electrode. This can produce some error, until thermal equilibrium is restored.

Appendix C

Interferent Gases and Vapors

Table C-1. Interferent Gases and Vapors		
Interferent	VOLUME % DRY	INTERFERENCE EQUIVALENT OF % O ₂
Carbon Dioxide	10%	0.1%
Cyclopropane	50%	0.2%
Desflurane	7.5%	0.1%
Diethyl Ether	20%	0.3%
Enflurane	4%	0.1%
Halothane	5%	0.2%
Helium	80%	0.2%
Isoflurane	3%	0.5%
Methoxyflurane	4%	0.1%
Nitrogen	80%	0.2%
Nitrous Oxide	80%	0.1%

Appendix D Troubleshooting

Table D-1. Troubleshooting		
PROBLEM	CAUSE	CORRECTIVE ACTION
Display is blank	Monitor is turned OFF or Battery is expired.	Press I/O to turn ON monitor
		If monitor does not respond, replace the battery
		If problem persists, call Ohio Medical Corporation service
No Response to keypad commands	Battery is expired	Press I/O to run ON monitor
		If monitor does not respond, replace the battery
		If problem persists, call Ohio Medical Corporation service
"SENSOR OFF" displays: visual and audible alarms activate	Cable is disconnected or malfunctioning	Check cable and sensor connections
	Sensor is disconnected	Visually check cable for damage. If necessary, replace cable
	Sensor membrane is perforated	If alert persists, replace sensor
	Thermistor circuit is open on the sensor circuit board	If alert persist following sensor replacement, call Ohio Medical Corporation service
During calibration, "CAL ERR" flashes, visual and audible alarms activate; then "CAL" flashes	Calibration performed using a gas other than room air or 100% oxygen or wrong calibration key pressed (100%/21%)	Recalibrate the monitor, ensure proper calibration key pressed for calibration gas of room air or 100% oxygen
		If alert persists, replace sensor
		If alert persists following sensor replacement, call Ohio Medical Corporation service
During operation, "CAL" flashes	Sensor signal is out of monitoring range	Recalibrate the monitor, ensure proper calibration key pressed for calibration gas of room air or 100% oxygen
		If alert persists, replace sensor
		If alert persists following sensor replacement, call Ohio Medical Corporation service
'LOW BAT' displays and monitor beeps every 30 seconds	Monitor has approximately six hours of operating time remaining	Replace the battery as soon as possible; then recalibrate the monitor and reset the high and low alarm values
"LOW BAT" displays "---" flashes, both visual alarms activate, and monitor emits a three-tone beep for four minutes; monitor shuts OFF	Battery is expired and monitor is not operating	Replace the battery as soon as possible; then recalibrate the monitor and reset the high and low alarm values
"ERR" and error code (01 to 08) display, visual and audible alarms activate and monitor locks	Microprocessor detects internal error	Note error code and see <i>Appendix E, Error Codes</i>
		Disconnect battery
		Call Ohio Medical Corporation service
Possible physical damage to instrument	Instrument is dropped and/or exposed to fluids	Turn instrument OFF, then ON to initiate self-test. If instrument is damaged, "ERR" and error code (01 to 08) display. Disconnect battery. Call Ohio Medical Corporation service

Appendix E Error Codes

The MiniOX® 3000 Oxygen Monitor performs diagnostic tests to detect errors that could cause unreliable monitor operation. These tests are performed:

- when a battery is installed (power-up)
- when the monitor is turned ON
- during routine monitoring

During self-test or any time the monitor detects an operational error, the MiniOX® 3000 Oxygen Monitor;

- ceases operation
- Display “ERR” and an error code
- activates visual and audible alarms

Error alarms continue until:

1. The monitor is shut off (press I/O)
2. The monitor is reset and error does not reoccur (press set)
3. The battery is disconnected

If an error reoccurs, the monitor is inoperative and must not be used; call Ohio Medical Corporation Repair at:

866-549-6446, Option #1

The error code that appears on the display corresponds to a specific failure. The audible alarm is a beep that corresponds to this code (e.g., “ERR 3” triggers a three-beep alarm).

Table E-1. Error Codes	
ERROR DISPLAY	CORRESPONDING ERROR
01	System error
02	Random Access Memory (RAM) error
03	Read Only Memory (ROM) error
04	Analog error
05	Timing error
06	Keypad error*
07	Battery error **
08	LCD error
*Press SET. If error reoccurs, call Ohio Medical Corporation Repair	
**Replace battery. If error reoccurs, call Ohio Medical Corporation Repair	

Appendix F

Accessories and Replacement Parts

Table F-1, Accessories and Replacement Parts	
ITEM	PART NO.
Oxygen Sensor	406931
Mounting Bracket (Pole)	474664
Mounting Bracket (Wall)	10023945
Coiled Cable	472045
Tee Adapter	473021
Retaining Strap	634249
Operation Manual on CD	600700
Operation Manual, printed	814358
MiniOX® 3000 Oxygen Monitor	814365
Battery Cover Assembly	710974
Battery Cover Screw, Knurled	655579
Deflector	803229
Dovetail	474606
Screw, #4x1/4" (set of 4) thread forming	450001
Servicing	
Inspection and Servicing	SVC-301
Cleaning, Calibration and Testing	SVC-302
Enclosure Replacement	SVC-303
Circuit Board Replacement	SVC-304
Connector Replacement	SVC-305

NOTES



Ohio Medical Corporation®
1111 Lakeside Drive
Gurnee, IL 60031 USA
phone: 1-866-549-6446
fax: 1-847-855-6218
www.ohiomedical.com