

# FLUKE®

Biomedical

## 601PRO<sub>XL</sub> International Safety Analyzer

### Operators Manual

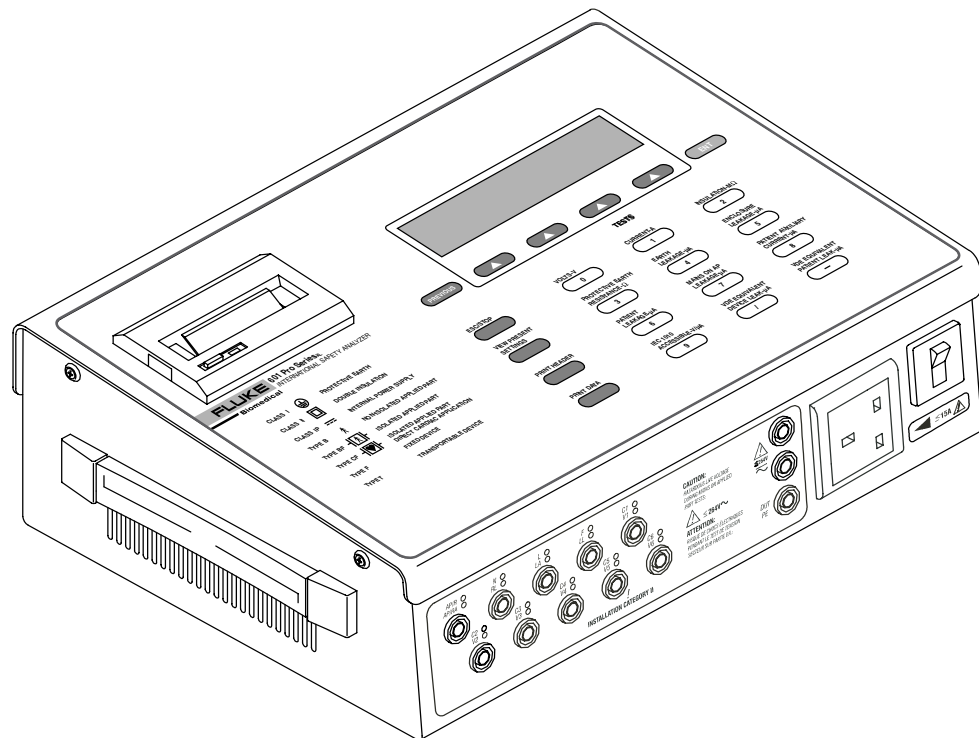

baw151f.eps

PN 2234222

April 2005

© 2005 Fluke Corporation, All rights reserved. Printed in USA.  
All product names are trademarks of their respective companies.



---

## Notices

### **Fluke Biomedical A Division of Fluke Electronics**

6920 Seaway Blvd.  
Everett, WA 98203  
USA

#### Customer Service and Sales

USA and Canada:	800.648.7952
Outside the USA:	775.883.3400
Sales E-Mail:	<a href="mailto:sales@flukebiomedical.com">sales@flukebiomedical.com</a>
Internet:	<a href="http://www.flukebiomedical.com">www.flukebiomedical.com</a>
Service:	888.993.5853
Outside the USA:	425.446.5560

For additional sales or service information, contact your local Fluke Biomedical Distributor or Fluke Electronics office

References in this manual to Bio-Tek Instruments, Inc. and DNI Nevada, refer to companies that are now part of Fluke Biomedical.

### **All Rights Reserved**

Copyright © 2005, Fluke Biomedical. All rights are reserved. No part of this manual may be reproduced, transmitted, transcribed, stored in a retrieval system, translated into any language, or transmitted in any form or by any means electronic or mechanical, including photocopying and recording, for any purpose other than the purchaser's personal use without written permission of Fluke Biomedical.

### **Manufacturing location**

Fluke Biomedical  
6920 Seaway Blvd  
Everett, WA 98203 USA  
775-883-3400  
800-648-7952

### **Trademarks**

IBM<sup>®</sup>, PC<sup>®</sup> and PC/AT<sup>®</sup> are registered trademarks of International Business Machines Corporation.

Microsoft<sup>®</sup> and MS-DOS<sup>®</sup> are registered trademarks of Microsoft Corporation.

### **Restrictions and Liabilities**







Information in this document is subject to change and does not represent a commitment by Fluke Biomedical. Changes made to the information in this document will be incorporated in new editions of the publication.

No responsibility is assumed by Fluke Biomedical Corporation for the use or reliability of software or equipment that is not supplied by Fluke Biomedical Corporation or its affiliated dealers.

## Warnings

Use of this instrument is restricted to qualified personnel who recognize shock hazards and are familiar with safety precautions used when operating electrical equipment. Read the manual carefully before operating the 601PRO.

☛ The following warning and informational symbols can be found on the 601PRO:

Symbol	Description
	<b>Caution: Risk of electric shock</b>
	<b>Direct / Alternating Current</b>
	<b>Protective Earth (PE)</b>
	<b>Caution: Refer to accompanying documentation</b>
	<b>Off (power: disconnection from Mains)</b>
	<b>On (Power: connection to Mains)</b>
	<b>Equipotential/Functional Earth (FE)</b>

- ☛ Exercise extreme caution when a shock hazard is present at the instrument's measurement terminals during the following tests:
  - Mains on Applied Part
  - Mains on Applied Part Calibration
  - Protective Earth Resistance
  - Protective Earth Resistance Calibration
  - Equivalent Patient Leakage
  - Equivalent Device Leakage
  - Equivalent Device/Patient Leakage Calibration



**FOR CORRECT OPERATION, ALL GROUND-REFERENCED PERIPHERALS, SUCH AS PRINTERS AND PCs, MUST BE DISCONNECTED.**

- ☛ Do not discharge a defibrillator while it is plugged into the 601PRO.
- ☛ Only use Fluke Biomedical-supplied test leads or leads rated for 32 Amps/1000 Volts with the Protective Earth Resistance Test.
- ☛ Inspect the lead ends for possible wear, cracks or breaks before each use.
- ☛ Take leakage current measurements only after earth resistance is measured and found to be compliant with the applied safety limit.
- ☛ External devices, such as printers and computers, attached to the 601PRO, may affect the 601PRO's ability to sense Open Earth conditions on the Mains input. If Mains voltage readings are in error, remove all external devices.
- ☛ If the DUT fails the Earth Resistance test, the operator must discontinue testing and label the DUT defective.
- ☛ If any single test fails, the test must be immediately discontinued and the DUT labeled defective.
- ☛ Prior to performing an ECG Simulation test, perform an Applied Part Leakage Test. If the Applied Part Leakage Test yields an instrument-under-test failure, then do not perform an ECG Simulation Test, as damage to the instrument may occur.
- ☛ If operating the 601PRO with a variable AC Supply (Variac), it is important to perform a calibration after changing the Mains Voltage level. Calibration can be performed from within the Mains On Applied Part, Equivalent Device Leakage, or Equivalent Patient Leakage tests.

---

## Nomenclature

### Comparable Terminology: International and United States

<b>INTERNATIONAL/IEC</b>	<b>U.S./AAMI</b>
L1	Hot
L2	Neutral
Earth	Ground
Mains	Line Voltage
Applied Parts	Patient Leads
Enclosure/Case	Chassis
Protective Earth	Ground Wire
Earth Leakage Current	Leakage in Ground Wire
Enclosure Leakage	Chassis Leakage
Patient Leakage	Lead Leakage
Patient Auxiliary	Leakage between Patient Leads
Mains on Applied Parts	Lead Isolation
Insulation Resistance	Dielectric Strength or Insulation Resistance between Hot and Neutral to Ground
Earth Resistance	Ground Wire Resistance

---

## Hazard Warnings

- ☛ **Warning! Power Rating.** The 601PRO's mains power input must be connected to a power receptacle that provides voltage within the specified rating for the system. Connection must be made via the Mains Power cord provided by Fluke Biomedical.

Use of an incompatible power receptacle or incorrect Mains Power cord may produce electrical shock and fire hazards. Acceptable Mains Voltage ranges are 90~VAC to 132~VAC, and 180~VAC to 240~VAC 50/60 Hz. The current ratings for the 601PRO are as follows:

Europe:	<=15A (Fused by 15A circuit breaker)
United Kingdom:	<=13A (Fused by 13A fused Mains Power Cord)
Australia:	<=10A (Fused by 10A circuit breaker)

- ☛ **Warning! Internal Voltage.** Always turn off the power switch and unplug the power cord before cleaning the 601PRO's outer surface.
- ☛ **Warning! Liquids.** Avoid spilling liquids on the analyzer; fluid seepage into internal components creates a potential shock hazard. Do not operate the instrument if internal components are exposed to fluid.

---

## Precautions

The following precautions are provided to help you avoid damaging the system:

- ☛ **To power up the 601PRO, place the index finger on the rocker switch and use a rolling motion to push from "OFF" to "ON." Do NOT forcefully push or snap the rocker switch. This may cause the unit to shut off.**
- ☛ **Caution: Service.** The 601PRO should be serviced by authorized service personnel. Only qualified technical personnel should perform troubleshooting and service procedures on internal components.
- ☛ **Caution: Environmental Conditions.** Do not expose the system to temperature extremes. Ambient temperatures should remain between 18-40°C. System performance may be adversely affected if temperatures fluctuate above or below this range.
- ☛ **Caution: Do Not Immerse.** Clean only with a mild detergent, and wipe down with a gentle cloth.

---

## Electromagnetic Interference and Susceptibility

### ☛ USA FCC CLASS A

**Warning:** Changes or modifications to this unit not expressly approved by the manufacturer could void the user's authority to operate the equipment.

This equipment has been tested and found to comply with the limits for a Class A digital device, pursuant to Part 15 of the FCC Rules.

These limits are designed to provide reasonable protection against harmful interference when the equipment is operated in a commercial environment. Like all similar equipment, this equipment generates, uses, and can radiate radio frequency energy and, if not installed and used in accordance with the instruction manual, may cause harmful interference to radio communications. Operation of this equipment in a residential area is likely to cause interference, in which case the user will be required to correct the interference at his own expense.

### ☛ Canadian Department of Communications Class A

This digital apparatus does not exceed Class A limits for radio emissions from digital apparatus set out in the Radio Interference Regulations of the Canadian Department of Communications.

Le present appareil numerique n'emet pas du bruits radioelectriques dépassant les limites applicables aux appareils numerique de la Class A prescrites dans le Reglement sur le brouillage radioelectrique edicte par le ministere des Communications du Canada.

---

## User Safety

This device has been type tested by an independent laboratory and found to meet the requirements of the following:

### **Canadian Standards Association CAN/CSA**

C22.2 No.1010.1-1992, "Safety Requirements for Electrical Equipment for Measurement, Control and Laboratory Use, Part 1: General Requirements".

### **UL 3101-1**

"Electrical Equipment for Laboratory Use, Part 1: General Requirements".



Based on the testing described below, this instrument bears the CE mark.

---

## EC Directive 89/336/EEC Electromagnetic Compatibility

### • Emissions - CLASS A

The system has been type tested by an independent, accredited testing laboratory and found to meet the requirements of EN 61326-1:1998 for Radiated Emissions and Line Conducted Emissions. Verification of compliance was conducted to the limits and methods of the following:

CISPR 16-1:1993 and CISPR 16-2:1996

### • Immunity

The system has been type tested by an independent, accredited testing laboratory and found to meet the requirements of EN 61326-1:1998 for Immunity. Verification of compliance was conducted to the limits and methods of the following:

EN 61000-4-2 (1991) Electrostatic Discharge

EN 61000-4-3 (1995) Radiated EM Fields

EN 61000-4-4 (1995) Electrical Fast Transient/Burst

EN 61000-4-5 (1995) Surge Immunity

EN 61000-4-6 (1996) Conducted Disturbances

EN 61000-4-11 (1994) Voltage Dips, Short Interruptions and Variations

---

## EC Directive 73/23/EEC Low Voltage (Safety)

The system has been type tested by an independent testing laboratory and found to meet the requirements of EC Directive 73/23/EEC for Low Voltage. Verification of compliance was conducted to the limits and methods of the following:

### EN 61010-1 (1993) & IEC 1010-1

“Safety Requirements for Electrical Equipment for Measurement, Control and Laboratory Use, Part 1: General requirements” (including amendments 1 & 2).

## Warranty

This Warranty is limited and applies only to new products, except for computer-based software, which is covered under a separate Warranty Policy, manufactured by Fluke Biomedical. Fluke Biomedical makes no warranty statement regarding the condition of used products.

Fluke Biomedical warrants the instrument (hereinafter collectively referred to as "Products" or "Product") for a period of one (1) year from the original purchase date against defective materials or workmanship. This Warranty is limited to the original purchaser (the "Purchaser") and cannot be assigned or transferred. All claims under this Limited Warranty must be made in writing to Fluke Biomedical, Attention: Service Department. Purchaser must ship the Product to Fluke Biomedical, postage pre-paid. Fluke Biomedical shall either repair or replace with new or like new, at its option and without cost to the Purchaser, any Product which in Fluke Biomedical's sole judgment is defective by reason of defects in the materials or workmanship.

This Warranty is VOID if the Product has been damaged by accident or misuse, or has been damaged by abuse or negligence in the operation or maintenance of the Product, including without limitation unsafe operation, operation by untrained personnel, and failure to perform routine maintenance. This Warranty is VOID if the Product has been repaired or altered by persons not authorized by Fluke Biomedical, or if the Product has had the serial number altered, effaced, or removed. This Warranty is VOID if any of the Products has not been connected, installed or adjusted strictly in accordance with written directions furnished by Fluke Biomedical. Batteries, fuses, light bulbs, and other "consumable" items used in any of the Products are not covered by this Warranty. Software utilized in conjunction with any of the Products is not covered by the terms of this Warranty but may be covered under a separate Fluke Biomedical software warranty.

We will continue to stock parts for a maximum period of five (5) years after the manufacture of any equipment has been discontinued. Parts shall include all materials, charts, instructions, diagrams, and accessories that were furnished with the standard models.

THIS WARRANTY CONTAINS THE ENTIRE OBLIGATION OF FLUKE BIOMEDICAL, AND NO OTHER WARRANTIES, EXPRESSED, IMPLIED, OR STATUTORY ARE GIVEN. PURCHASER AGREES TO ASSUME ALL LIABILITY FOR ANY DAMAGES AND/OR BODILY INJURY OR DEATH THAT MAY RESULT FROM THE USE OR MISUSE OF ANY EQUIPMENT OR INSTRUMENT BY THE PURCHASER, HIS EMPLOYEES, AGENTS, OR CUSTOMERS, OTHER THAN THE EXPRESS WARRANTY CONTAINED HEREIN. WE SHALL NOT BE RESPONSIBLE FOR ANY DIRECT OR CONSEQUENTIAL DAMAGES OF ANY KIND. THIS WARRANTY SHALL NOT BE CHANGED OR MODIFIED IN ANY WAY WITHOUT THE EXPRESS WRITTEN PERMISSION OF AN OFFICER OF FLUKE BIOMEDICAL.

THIS WARRANTY IS VOID UNLESS THE PURCHASE REGISTRATION CARD HAS BEEN COMPLETED AND MAILED TO US WITHIN TEN (10) DAYS OF PURCHASE.

## Contents

Notices .....	ii
Warnings .....	iii
Nomenclature .....	v
Hazard Warnings .....	vi
Precautions .....	vi
Electromagnetic Interference and Susceptibility .....	vii
Safety .....	vii
Warranty .....	ix

### Chapter 1: Introduction and Description

Introduction to the 601PRO Series <sub>XL</sub> .....	1-1
Accessories .....	1-3
Optional Accessories .....	1-3
Menu Structure .....	1-3
System Characteristics .....	1-5
Audio Feedback .....	1-5
Top Panel .....	1-6
Keys Used to Enter Device Control Numbers .....	1-7
Front Panel .....	1-8
Back Panel .....	1-9
Statement of Compatibility .....	1-10

### Chapter 2: Setting Up the 601PRO

Using Factory Default Settings .....	2-1
Selecting the Test Standard .....	2-2
Selecting the Printer Output .....	2-3
Selecting the RS232 Baud Rate .....	2-4
Activating the Beeper .....	2-5
Setting the Time and Date .....	2-6
Configuring the Enclosure Leakage for the Auto Mode Sequence .....	2-8
Selecting Language Options .....	2-9
Selecting the DC Option .....	2-10
Selecting the Auto/Step Tests: Controlled Power Sequences or 601CE Conventional Test Sequences .....	2-11
Enabling Stop on Failure .....	2-13
Configuring for Device Records or Templates .....	2-15

**Chapter 3: Manual Mode**

Connecting the Device Under Test .....	3-1
The Power-Up Sequence .....	3-2
Selecting the Test Standard .....	3-3
Selecting the Class/Type .....	3-4
Saving Standard, Class, Type and Test Current .....	3-6
Using View Present Settings .....	3-7
Lead Type Definitions .....	3-9
Manual Operation.....	3-13
Additional Features .....	3-14
Shortcut Key 0: Mains Voltage Test and Dual Lead Voltage Test .....	3-16
Shortcut Key 1: Current Consumption Test.....	3-17
Shortcut Key 2: Insulation Resistance Test .....	3-18
Shortcut Key 3: Protective Earth Resistance Test .....	3-20
Shortcut Key 4: Earth Leakage Test .....	3-22
Shortcut Key 5: Enclosure Leakage Test.....	3-23
Shortcut Key 6: Patient Leakage Current Test (IEC 601-1 or VDE 751-1 Test Standard).....	3-24
Shortcut Key 7: Mains on Applied Part Leakage Test (IEC 601-1).....	3-26
Shortcut Key 8: Patient Auxiliary Current Test.....	3-28
Shortcut Key 9: IEC 1010 Accessible Voltage/ Leakage Test .....	3-30
Accessible Voltage .....	3-30
Accessible Leakage .....	3-31
Shortcut Key /: VDE Equivalent Device Leakage Test.....	3-32
Shortcut Key - : VDE Equivalent Patient Leakage Test.....	3-34
Dual Lead Leakage .....	3-36
ECG Output .....	3-37
Sample Waveforms .....	3-38

**Chapter 4: Auto/Step Modes**

Selecting Auto or Step Mode Testing .....	4-1
Executing Auto and Step Mode Tests .....	4-4
Creating/Editing a Device Record or Template .....	4-7

**Chapter 5: Test Records**

Sending Test Results from the 601PRO to the Host Computer .....	5-1
Test Data Record: Serial Output .....	5-3
Printing Test Records .....	5-3
Deleting Test Records .....	5-3
Printing a Header.....	5-5

**Chapter 6: Device Records and Templates**

Setup Requirements.....	6-1
Using the Device Information Record Utility .....	6-1
Connecting the 601PRO and the Host Computer.....	6-2
Sending Device Information Records from the 601PRO to the Host Computer .....	6-2
Receiving Device Information Records from the Host Computer .....	6-3
Device Information Record: Definition of Fields .....	6-5
Device Information Record Format .....	6-6
Deleting Device Records and Templates .....	6-7

**Chapter 7: Testing Devices**

Permanently Wired Devices.....	7-1
Portable Devices .....	7-2
Portable Devices in Isolated Power Systems .....	7-2
Testing Three-Phase Portable Devices.....	7-2
Testing Conductive Surfaces.....	7-3
Detachable Power Supply Cable .....	7-3
Battery-Powered Equipment .....	7-3

**Chapter 8: Standards and Principles**

Accessing System Setup..... 8-2  
Selecting the Test Standard..... 8-2  
Referring to Test Limits for the Selected Standard..... 8-2

**Chapter 9: Custom Standards**

Defining/Editing a Custom Standard ..... 9-1  
Tests Available in a Custom Standard ..... 9-4  
Custom Standard Controlled Power Sequence..... 9-5

**Chapter 10: Computer Control**

Setup Requirements..... 10-1  
Establishing Computer Control..... 10-2  
    Connecting the 601PRO and the Host Computer..... 10-2  
    Sending the Command from the Host Computer ..... 10-2  
Command Protocol..... 10-2  
Computer Control Commands..... 10-4

**Chapter 11: Error Messages, Troubleshooting, and Support**

Error Codes ..... 11-1  
Errors and Suggested Corrective Actions ..... 11-2  
Troubleshooting ..... 11-3  
Technical Assistance ..... 11-3  
Service..... 11-3  
    Shipping Requirements ..... 11-3

**Appendix A: Specifications**

**Appendix B: Keyboard Options/Barcode Keyboard Wedge**

**Appendix C: Printer Maintenance**

**Appendix D: Test Data Record ASCII Character Formats**

---

# Introduction and Description

Chapter

1

- 1. Introduction to the 601PRO Series<sub>XL</sub>**
- 2. Accessories**
- 3. Optional Accessories**
- 4. Menu Structure**
- 5. System Characteristics**
- 6. Statement of Compatibility**

## **1. Introduction to the 601PRO Series<sub>XL</sub>**

The 601PRO Series<sub>XL</sub> (601PRO) is an automated electrical safety analyzer that meets stringent international standards for electrical safety testing of hospital and laboratory electromedical equipment.

The 601PRO conducts electrical safety testing in accordance with IEC 601-1, VDE 751, VDE 701, HEI 95, IEC 1010, AAMI, and AS/NZS 3551 requirements, flags failures, and simulates performance, ECG, and arrhythmia waveforms. The 601PRO stores 1000 device records. Test results, which are automatically analyzed and saved in non-volatile memory, can be printed using the internal ZY column thermal printer or an attached external printer, or uploaded to a PC using the serial port.

The 601PRO offers automatic, manual, computer control, or step mode operation.

The 601PRO will accept device information that is input using an external keyboard, integrated keypad, or barcode keyboard wedge.

Available electrical safety tests include:

- ◆ Mains Voltage
- ◆ Dual Lead Voltage
- ◆ Dual Lead Leakage
- ◆ Current Consumption
- ◆ Insulation Resistance
- ◆ Protective Earth Resistance
- ◆ Earth Leakage Current
- ◆ Enclosure Leakage Current
- ◆ Patient Leakage Current
- ◆ Mains on Applied Part Leakage
- ◆ Patient Auxiliary Current
- ◆ Accessible Voltage
- ◆ Accessible Leakage
- ◆ Equivalent Device Leakage
- ◆ Equivalent Patient Leakage

Available ECG performance waveforms include:

- ◆ Square wave: 0.125, 2 Hz
- ◆ Sine wave: 10, 40, 50, 60, 100 Hz
- ◆ Triangle wave: 2 Hz
- ◆ ECG complex: 30, 60, 120, 180, 240 BPM
- ◆ Pulse: 30, 60 BPM
- ◆ A-Fib, A-Flutter, A-Tach, Idioventricular, PVC1, R-on-T, Run, V-Fib, V-Tach

## 2. Accessories

The following accessories are shipped standard with the 601PRO. To order additional quantities, contact your Fluke Biomedical equipment dealer, and use the Fluke Biomedical Part Numbers provided.

<b>Description</b>	<b>Quantity Supplied</b>	<b>Part #</b>
Probe/Safety Lead, Red	1	2213252
Probe/Safety Lead, Black	1	2213241
Adapter, Banana/Alligator	5	2212941
Operators Manual	1	2234222
Large Clamp, Red	1	2004125
Warranty Card	1	2241856
Printer Paper Roll (original)	1	2248719
Printer Paper Roll (new style)	1	2248743

## 3. Optional Accessories

The following optional accessories are available for the 601PROXL. To order, contact a Fluke Biomedical equipment dealer and use the Fluke Biomedical part numbers provided.

<b>Description</b>	<b>Part #</b>
Carry Case	2234065
RS232 Cable (9M-9F)	2238659
Printer Cable	2238072
Barcode, Keyboard, Wedge	2248255
Adapter, Banana, ECG	2212657
Keyboard English	2213184
Powercord Set Australian	2238603
Powercord Set Schuko	2238015
Powercord Set US 120 V	2286644
Powercord Set UK	2238570

## 4. Menu Structure

A layout showing various system functions is provided on the following page.



## 5. System Characteristics

The 601PRO uses a *membrane* keypad for selection of tests or menu options. The keys are grouped by color and functionality. The **red** keys below the display are used to access menu options. These include the **previous** key, the four **SOFT KEYS**, and the **enter** key. The **black** keys allow the operator to gain access to additional functions. These include the **esc/stop** key, the **view present settings** key, the **print header** key, and the **print data** key.

The **red** keys numbered **0** through **–** are used to enter information and can also be used to gain quick access to the manual tests.

---

### AUDIO FEEDBACK

- A **one-beep** signal indicates that a key has been pressed.
- A **two-beep-per-second** signal indicates high voltage or current generated by the 601PRO is present.

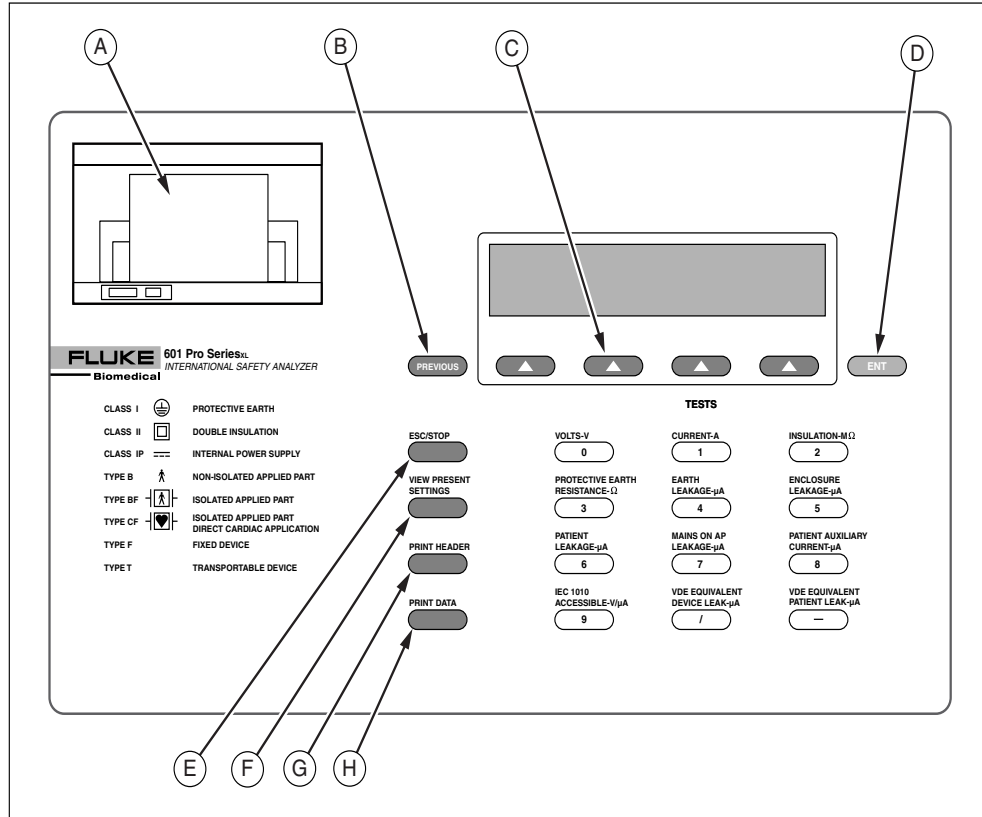

Baw152f.eps

Figure 1-1: 601PRO Top Panel Illustration

### Top Panel: Identifying 601PRO Components

Use the drawing of the 601PRO top panel, displayed above, to locate the following components.

- |          |                                  |   |
|----------|----------------------------------|---|
| <b>A</b> | <b>Printer</b>                   | Optional 24-character printer for immediate hard copy of results.   |
| <b>B</b> | <b>Previous Key</b>              | Returns user to the previous screen.  |
| <b>C</b> | <b>Soft Keys 1-4</b>             | Make dynamic assignments based on current screen.   |
| <b>D</b> | <b>Enter Key</b>                 | Advances to the next menu or saves/selects options.   |
| <b>E</b> | <b>Esc/Stop Key</b>              | Discontinues current test and returns operator to the <b>MAIN MENU</b> . Turns off the DUT outlet.  |
| <b>F</b> | <b>View Present Settings Key</b> | Advances to View Present Settings screen when at the <b>MAIN MENU</b> . Displays current settings and allows operator to edit test standard, class/type, and lead assignments (see page 3-7). |
| <b>G</b> | <b>Print Header Key</b>          | Sends device information fields to enabled printer.   |
| <b>H</b> | <b>Print Data Key</b>            | Sends displayed test data to printer.   |

**Keys Used to Enter Device Control Numbers**

The keys described below (**0** through **—**) can be used to enter test control numbers in the auto/step modes of operation. These keys are also referred to as **test-shortcut keys** and can be used to initiate manual tests.

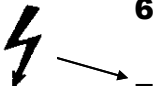
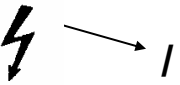
	<b>0</b>	<b>Volts</b>	In single lead mode, displays mains voltage. In dual lead mode, displays voltage between RED and BLACK test leads.
	<b>1</b>	<b>Current</b>	Measures the current consumption (in amperes) of the device under test.
	<b>2</b>	<b>Insulation</b>	Tests insulation resistance (mains to case or applied parts to case).
	<b>3</b>	<b>Protective Earth Resistance</b>	Measures the earth resistance using a 1A test current (unless 10A or 25A is selected).
	<b>4</b>	<b>Earth Leakage</b>	Is measured between the DUT “Protective Earth” terminal and the “Protective Earth” terminal of the 601PRO.
	<b>5</b>	<b>Enclosure Leakage</b>	In single-lead mode, measures the enclosure leakage (RED test lead to DUT protective earth on the 601PRO).
	<b>6</b>	<b>Patient Leakage</b>	Measures the patient leakage current (applied part to earth).
	<b>7</b>	<b>Mains on Applied Part Leakage</b>	Applies 110% mains voltage to selected applied part and measures leakage to earth in both normal and reverse polarity. Does not apply to patient auxiliary selections.
	<b>8</b>	<b>Patient Auxiliary Current</b>	Measures the leakage and biasing current between applied parts.
	<b>9</b>	<b>IEC 1010 Accessible Voltage/Leakage</b>	Selects the IEC 1010 Test Load. Measures accessible voltage through the RED jack to 601PRO earth. Allows access to the accessible leakage test.
	<b>/</b>	<b>VDE Equivalent Device Leakage</b>	Selects the IEC 601 test load. Applies 110% of mains voltage between L1/L2 and earth.
	<b>—</b>	<b>VDE Equivalent Patient Leakage</b>	Selects the IEC 601 test load. Applies 110% of mains voltage to the selected applied part and measures the leakage.

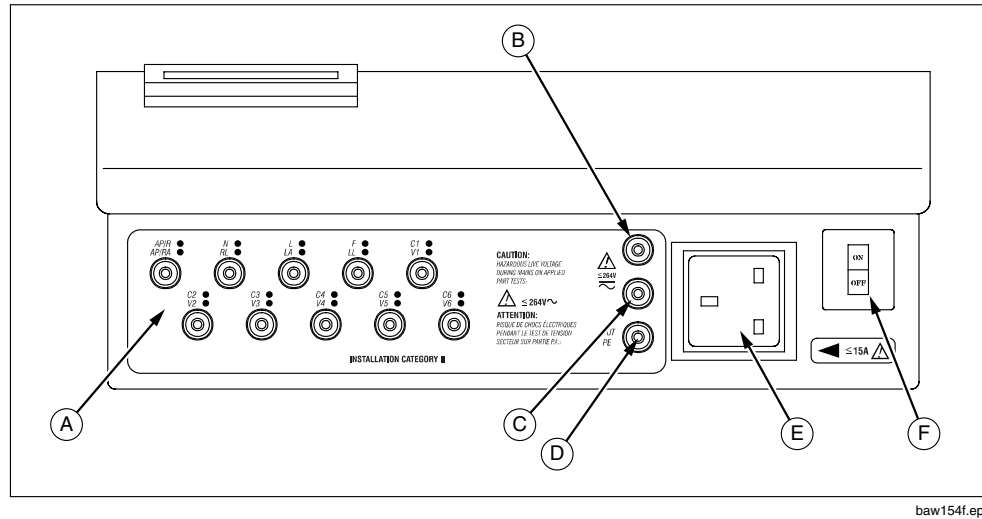
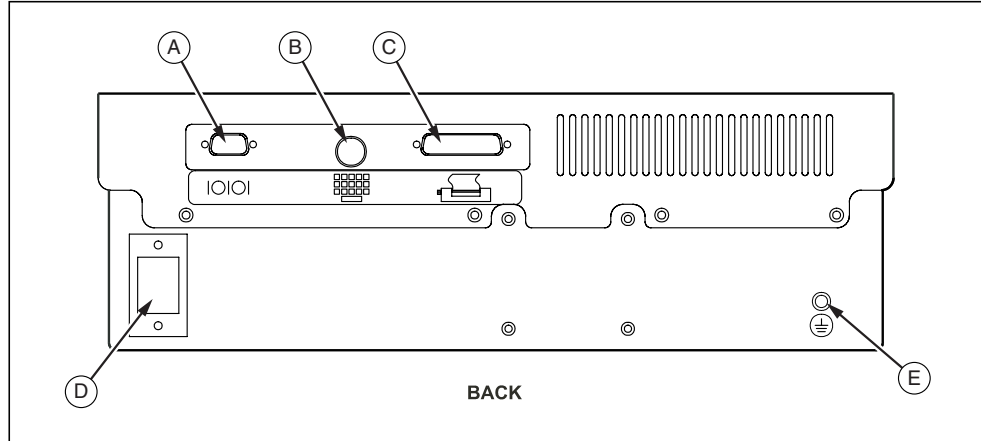

Figure 1-2: 601PRO Front Panel Illustration

## Front Panel

<b>A</b>	<b>Applied Part Terminal</b>	The jacks allow direct connection to banana jacks, or 4mm-to-alligator adapters provided.
<b>B</b>	<b>Red Input Terminal</b>	Single test lead connection.
<b>C</b>	<b>Black Input Terminal</b>	Used for dual lead testing in combination with red test lead.
<b>D</b>	<b>Green Input Terminal</b>	Protective Earth of Device Under Test.
<b>E</b>	<b>Power Outlet</b>	Allows standard power plug connection of the Device Under Test. 120V @ 15A or 240V @ 15A maximum.
<b>F</b>	<b>On-Off Switch / Circuit Breaker</b>	Power up the 601PRO, I=ON, 0=OFF; built-in ISA circuit breaker.

**Note:** To power up the 601PRO, place the index finger on the rocker switch and use a rolling motion to push from "OFF" to "ON." Do **NOT** forcefully push or snap the rocker switch. This may cause the unit to shut off.



baw155f.eps

Figure 1-3: 601PRO Back Panel Illustration

### Back Panel

- |                                      |  |
|--------------------------------------|--|
| <b>A RS232 Connection</b>            | Allows bi-directional computer control. Serial D-9 female connector. |
| <b>B Keyboard Input</b>              | Allows the use of an external keyboard for data input. DIN 5 socket. |
| <b>C Printer Connector</b>           | Allows for an external parallel printer. D-25 female connector.      |
| <b>D Power Cord Connection</b>       | 120V/15A or 240V/15A power cord connection.                          |
| <b>E Protective Earth Connection</b> | Provides a direct connection to the power cord ground.               |

## 6. Statement of Compatibility

The 601PRO is compatible with and has the same base features as the previous 601PRO safety analyzer. It also has some new features that include the following:

- Because of new features in this version of the 601PRO, the Device Record Format has been changed. If old format device records are transmitted to the 601PRO Series<sub>XL</sub> via RS232, they will be accepted. However, when receiving device records from the 601PRO, the new format will always be used. Refer to *Chapter 6* for details.
- Custom standard names are fixed. Any old-style device record received via RS232 must be updated to reflect this change. Refer to *Chapter 9* for more details.
- Supports all computer control commands from the previous 601PRO. Some of the commands no longer have meaning in the new 601PRO and have been given fixed responses. New commands have been added to support new features on the instrument. Refer to *Chapter 10* for complete details.
- Due to new features, the RS232 result output format has changed. It is very similar to the old format but has extra fields for the new features. **The transfer utility is no longer required or supported.** Refer to *Chapter 5* for complete details.
- Because the 601PRO now supports IEC 601, IEC 1010, and AAMI test loads, some changes in computer control commands have been made. All existing (previous) commands use the 601 test load. New commands have been created to support the new loads. Refer to *Chapter 10* for details.
- Unlike previous versions of the 601PRO, the 601PRO Series<sub>XL</sub> uses a standard D9M-D9F serial cable.

# Setting Up the 601PRO

Chapter

2

This chapter describes the factory default settings and how to change them, and provides instructions for one-time customization of the 601PROXL using the **SYSTEM SETUP** key and the **Select Setup Function** menu.

- 1. Using Factory Default Settings**
- 2. Selecting the Test Standard**
- 3. Selecting the Printer Output**
- 4. Selecting the RS232 Baud Rate**
- 5. Activating the Beeper**
- 6. Setting the Time and Date**
- 7. Configuring the Enclosure Leakage for the Auto Mode Sequence**
- 8. Selecting Language Options**
- 9. Selecting the DC Option**
- 10. Selecting the Auto/Step Tests: Controlled Power Sequences or 601CE Conventional Test Sequences**
- 11. Enabling Stop on Failure**
- 12. Configuring for Device Records or Templates**

## 1. Using Factory Default Settings

The factory default settings are shown below.

Description	Factory Default Setting
Test Standard	IEC 601-1 (Class I, BF)
Number of Applied Parts	0 (To change, refer to Chapter 3)
Printer Output	Internal
RS232	9600 Baud
Beeper	On
Time Format	24 hour
Date Format	MDY
Enclosure Leakage (multiple readings during the Auto Mode sequence)	Off
Keyboard Language	English
Display/Print Language	English
DC Readings	Off
Auto/Step Sequences: Controlled Power Sequence	On
Stop on Failure	Off
DEV RECS / TEMPLATES	DEVICE REC

## 2. Selecting the Test Standard

The **Select Test Standard** option allows the operator to choose among IEC 601-1, VDE 701-1, VDE 751-1, HEI 95, IEC 1010, AAMI, AS/NZS 3551, or custom standards.

Refer to *Chapter 8, Standards and Principles*, for a detailed discussion of IEC 601-1, VDE 701-1, VDE 751-1, HEI 95, IEC 1010, AAMI, and AS/NZS 3551 standards and their selection.

- At the 601PRO **MAIN MENU**, press **SYSTEM SETUP** to access the **Select Setup Function** menu. Press **TEST STANDARD**:

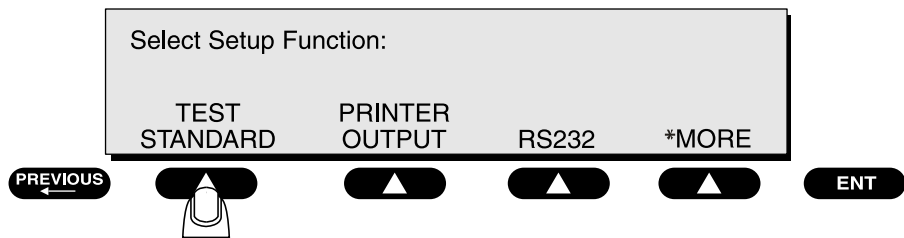

baw008f.eps

- At the **Select Test Standard** menu, select a test standard, or press **\*MORE** for additional standards.

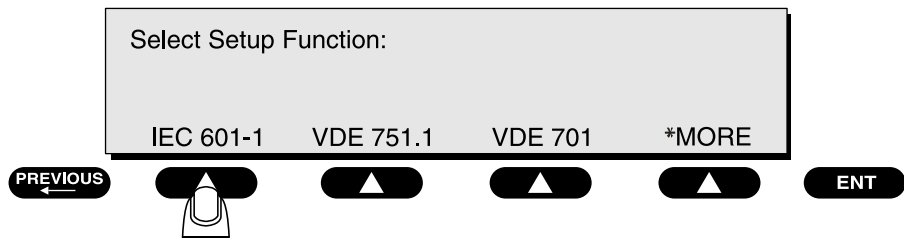

baw009f.eps

- Note:** To enable/disable the test standards that appear at the **Select Test Standard** menu, press **UTILITIES** at the **MAIN MENU**, then **\*MORE**, then **ENABLE STANDARDS**. Press **YES** or **NO** at the **Enable Test Standard** menu.

Once the selection is made, the 601PRO will automatically return to the **MAIN MENU** where the selected standard is displayed.

**Default Setting:** IEC 601-1

### 3. Selecting the Printer Output

Before testing, choose whether to use the optional internal printer, an external printer, or no printer.

- From the 601PRO **MAIN MENU**, press **SYSTEM SETUP** to access the **Select Setup Function** menu. Press **PRINTER OUTPUT**:

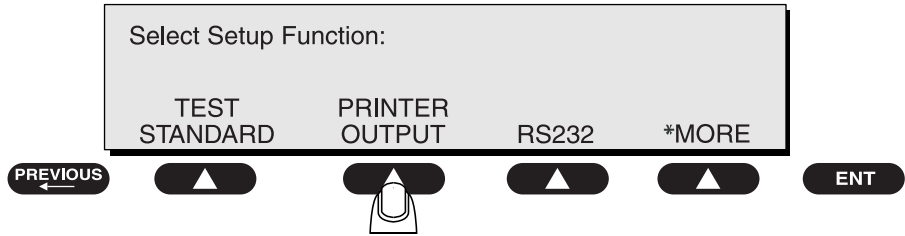

baw026f.eps

- At the **Printer Output** menu, use the **SOFT KEYS** to select a printer interface:

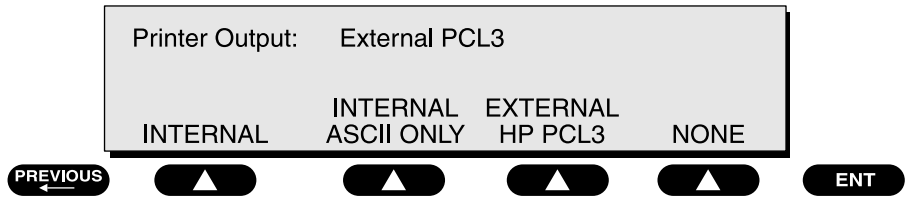

baw010f.eps

- ⇒ The **EXTERNAL ASCII ONLY** setting is for older (and some newer) printers that will interpret and print basic ASCII characters.
- ⇒ The **EXTERNAL HP PCL3** printer setting is for any HP printer that supports PCL3 (Printer Control Language, Version 3). The control sequence feature configures the printer and then downloads ASCII characters to it.

**Note:** Follow the printer manufacturer’s instructions for handling page ejects and printing using form-feed commands.

- Press **previous** or **enter** to save the settings and return to the **MAIN MENU**.

**Default Setting:** Internal

#### 4. Selecting the RS232 Baud Rate

To select the baud rate for the RS232 serial port:

- From the 601PRO **MAIN MENU**, press **SYSTEM SETUP** to access the **Select Setup Function** menu. Press **RS232**:

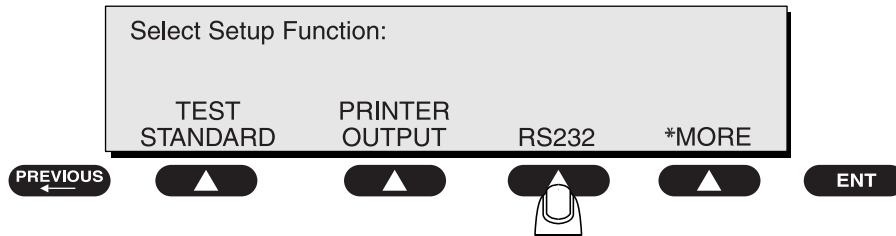

baw027f.eps

At the 601PRO **RS232 Settings** menu, press a **SOFT KEY** to select a baud rate:

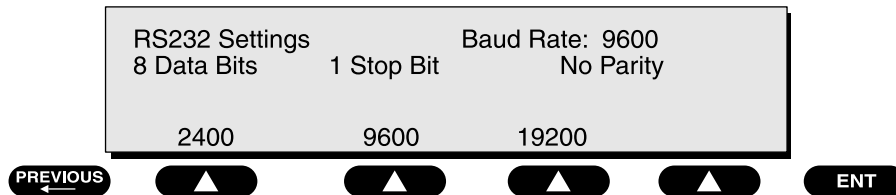

baw011f.eps

**Default Setting: 9600**

- Press **enter** to save the setting and return to the **Select Setup Function** menu. Press **previous** to return to the **MAIN MENU**.

## 5. Activating the Beeper

To activate/deactivate the beeper:

- From the 601PRO **MAIN MENU**, press **SYSTEM SETUP** to access the **Select Setup Function** menu. Press **\*MORE** until the following menu is displayed, then press **BEEPER**:

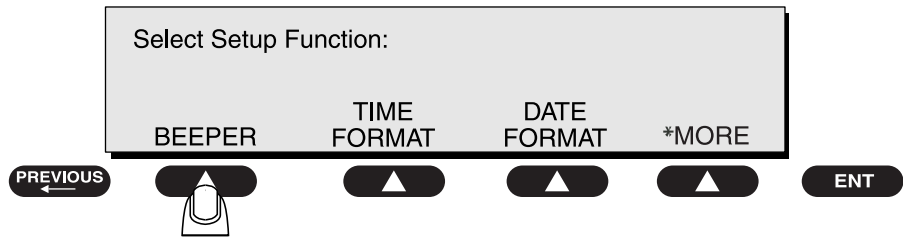

baw012f.eps

- Press a **SOFT KEY** to select **ON** or **OFF** at the **Key and Error Beeper** menu:

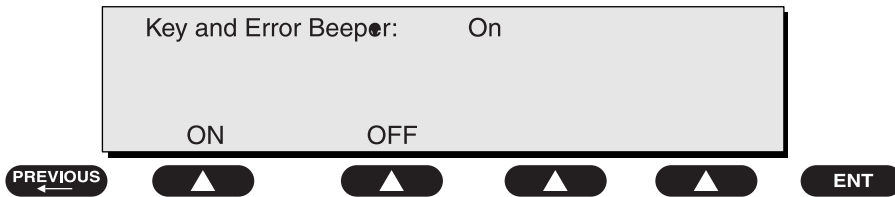

baw025f.eps

Selecting **OFF** will silence the beep that sounds when a key is pressed or when an error occurs. Selecting **OFF** will **not** disable the beeper during lead calibration or when performing tests using the beeper as a warning.

**Default Setting:** ON

- Press **enter** to save the settings and return to the **Select Setup Function** menu. Press **previous** to return to the **MAIN MENU**.

## 6. Setting the Time and Date

The time and date are used to record testing times and their associated dates. The clock can be set in either 12-hour or 24-hour format. The date format is either MM-DD-YY or DD-MM-YY.

To set the time format:

- From the 601PRO **MAIN MENU**, press **SYSTEM SETUP** to access the **Select Setup Function** menu. Press **\*MORE** until the following menu is displayed, then press **TIME FORMAT**:

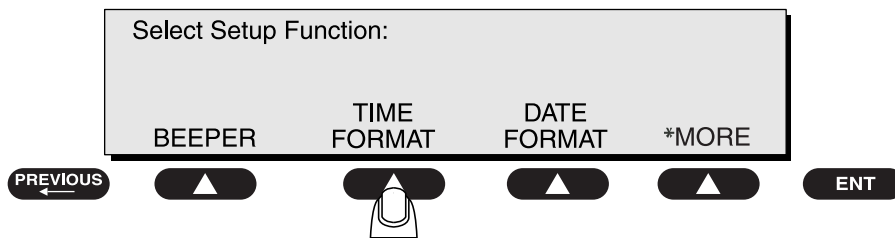

baw028f.eps

To set the time:

- At the following menu, press a **SOFT KEY** to select either the **12 HOUR** or **24 HOUR** format. Press the cursor **SOFT KEY** to change cursor position and enter the time of day using the **test-shortcut keys**.

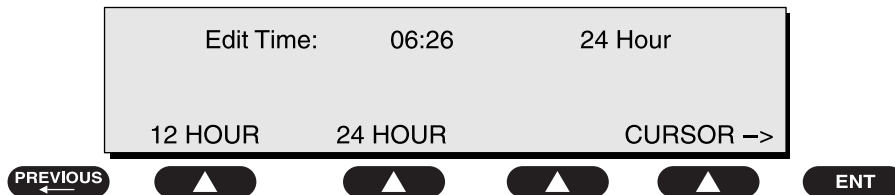

baw013f.eps

**Default Setting: 24 HOUR**

- Press **enter** to save the settings and return to the **Select Setup Function** menu. Press **previous** to return to the **MAIN MENU**.

To set the date format:

- From the 601PRO **MAIN MENU**, press **SYSTEM SETUP** to access the **Select Setup Function** menu. Press **\*MORE** until the following menu is displayed, then press **DATE FORMAT**:

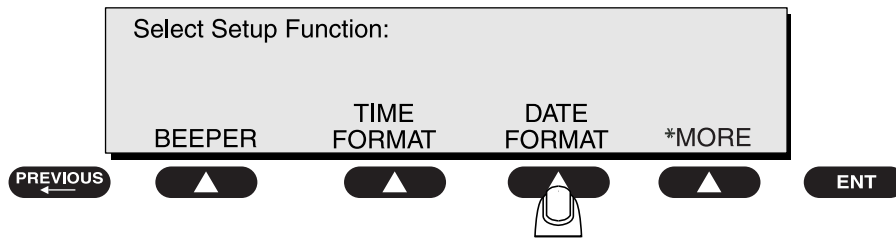

To set the date:

- At the following menu, press a **SOFT KEY** to select either **MM/DD/YY** or **DD/MM/YY**. Press a **SOFT KEY** to move the cursor in either direction. Use the **test-shortcut keys** to enter the date.

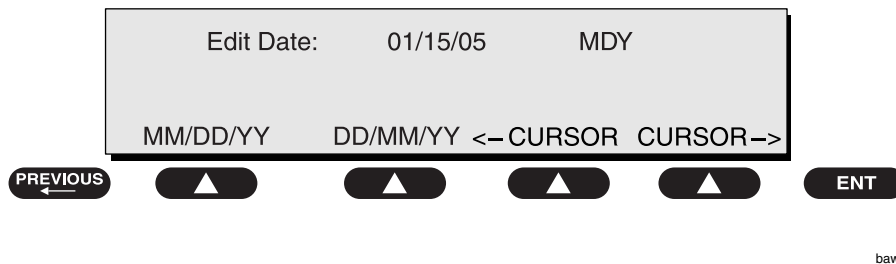

**Default Setting: MDY**

- Press **enter** to save the settings and return to the **Select Setup Function** menu. Press **previous** to return to the **MAIN MENU**.

## 7. Configuring the Enclosure Leakage for the Auto Mode Sequence

To take multiple **Enclosure Leakage** readings when performing tests in **Auto** mode:

- From the 601PRO **MAIN MENU**, press **SYSTEM SETUP** to access the **Select Setup Function** menu. Press **\*MORE** until the following menu is displayed, then press **ENCLOSURE LEAKAGE**:

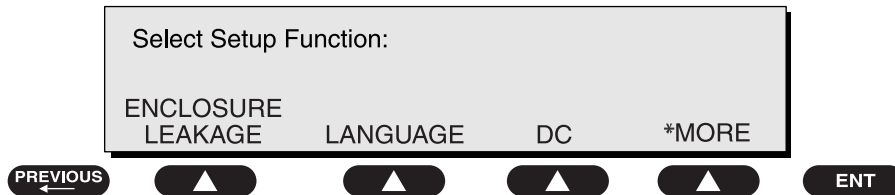

- At the following menu, press **YES**.

baw015f.eps

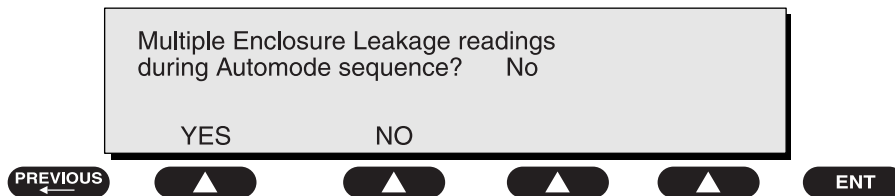

baw016f.eps

**Default Setting: NO**

- Press **enter** to save the setting and return to the **Select Setup Function** menu. Press **previous** to return to the **MAIN MENU**.

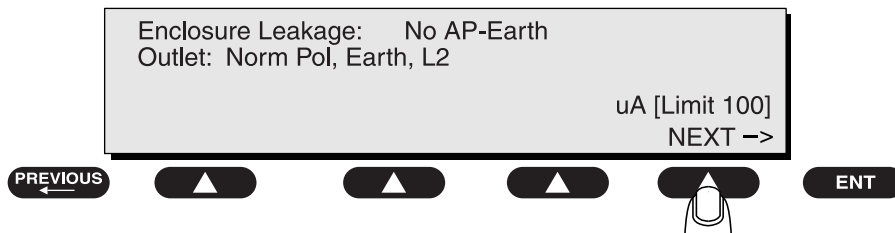

baw017f.eps

Thereafter, whenever an **Enclosure Leakage** test is performed as part of an **Auto** sequence, readings will be continually taken until **NEXT->** is pressed. The last reading taken will then be used to determine Pass/Fail.

- Note:** If running a custom standard auto sequence while multiple leakage readings are enabled, the operator may experience a delay of up to 30 seconds when taking DC readings before the next test begins.

Refer to *Chapter 4, Auto/Step Modes*, for more information.

## 8. Selecting Language Options

The **Language** option allows the operator to select an English, French, German, or Italian external keyboard, and also to select the print and display language. Supported keyboards are described in *Appendix B*. To configure the **Language** option:

- From the 601PRO **MAIN MENU**, press **SYSTEM SETUP** to access the **Select Setup Function** menu. Press **\*MORE** until the following menu is displayed, then press **LANGUAGE**:

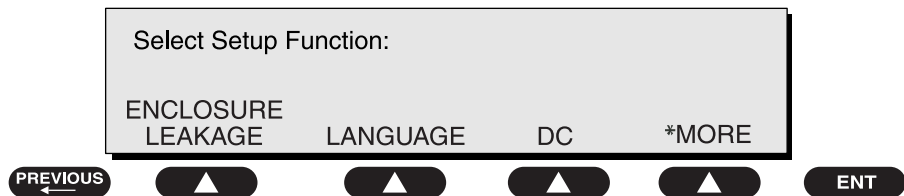

baw015f.eps

- At the following menu, press a **SOFT KEY** to select a keyboard language:

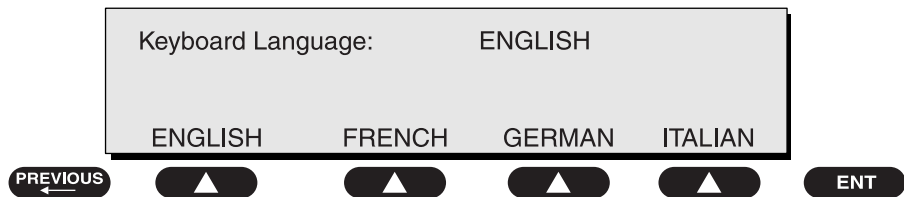

baw018f.eps

- Press **enter**. At the following menu, press a **SOFT KEY** to select a print/display language:

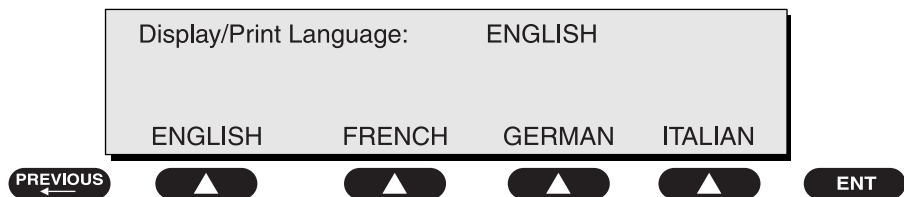

baw019f.eps

**Default Setting: ENGLISH**

- Press **enter** to save the settings and return to the **Select Setup Function** menu. The unit will immediately be reconfigured with the new selections. Press **previous** to return to the **MAIN MENU**.

## 9. Selecting the DC Option

The **DC** option permits the operator to disable all DC readings, allowing the **Auto/Step** sequences to run faster. This applies to all sequences, including Custom, and all modes (**Auto/Step/Manual**), except for IEC 1010 sequences and **Computer Control**. The 601PRO SERIES<sub>XL</sub> units are supplied with DC readings disabled.

- To enable/disable DC readings: From the 601PRO **MAIN MENU**, press **SYSTEM SETUP** to access the **Select Setup Function** menu. Press **\*MORE** until the following menu is displayed, then press **DC**:

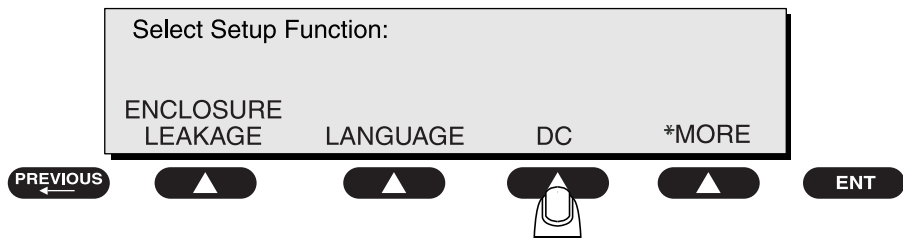

- Press **YES** or **NO** at the following menu:

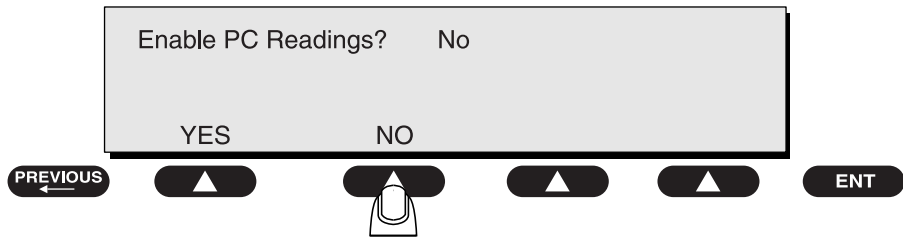

**Default Setting:    No**

**10. Selecting the Auto/Step Tests: Controlled Power Sequences or 601CE Conventional Test Sequences**

The **Auto/Step Sequences** option allows the operator to choose between the controlled power sequences or the conventional test sequences popular in the older 601PRO CE units.

To run conventional test sequences, it is necessary to disable the controlled power sequences for IEC 601 and HEI 95 **Auto/Step** sequences. To access this function, press **\*MORE** at the **Select Setup Function** menu as shown:

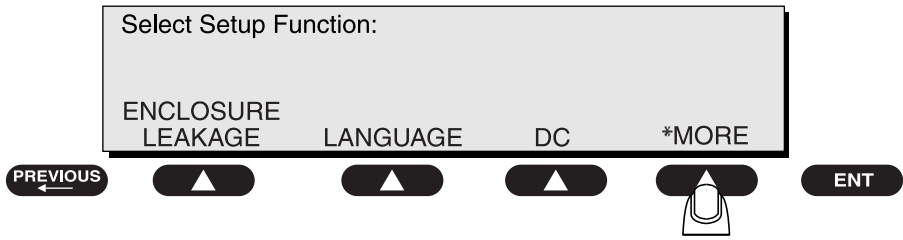

baw031f.eps

This will display the following:

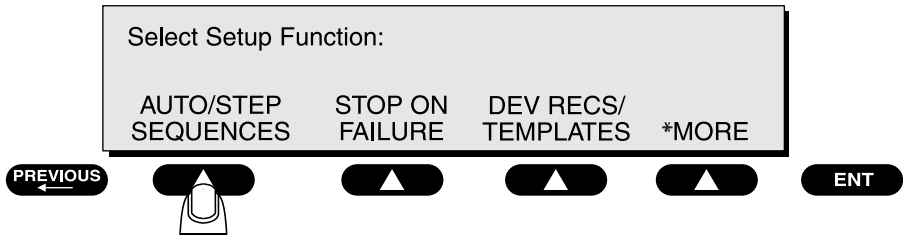

baw001f.eps

- Press **YES** or **NO** at the following menu:

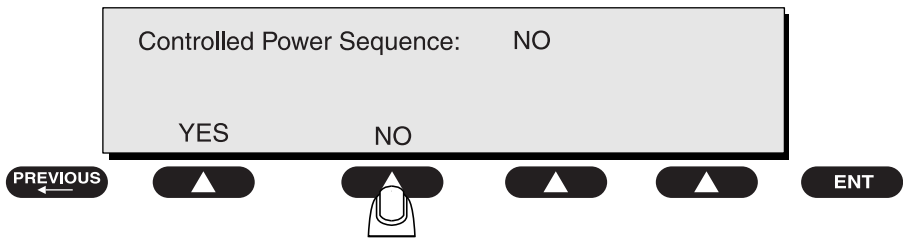

baw021f.eps

**Default Setting: Yes**

For the controlled power sequences, refer to *Chapter 8, Standards and Principles*, pages 8-5 and 8-6 for IEC 601 test limits, and page 8-12 for HEI 95 test limits.

Although the conventional test sequences are performed in a different order, the results and printed output are in the same order as the controlled power sequences. See *Chapter 8*, pages 8-7 through 8-9 for IEC 601 test limits, and page 8-13 for HEI 95 test limits.

The 601PRO, not the device record, determines which sequence is used. The 601PRO SERIES<sub>XL</sub> units are supplied with the controlled power sequences disabled.

☛ **Note:** The setup options that are defined are **not** saved with the device records.

Startup and Power Off Delays have been inserted into the conventional test sequences to allow customization of the sequence. Long or short delays can be programmed into a device record, considering the specific device under test. The Power Off Delay, for all sequences, has a range of 1 to 9999 seconds. The Startup Delay has a range of 0 to 9999 seconds.

☛ **Note:** In **Auto/Step** mode, Startup and Power Off delays are performed, regardless of the tests enabled.

### 11. Enabling Stop on Failure

The **Stop On Failure** option allows the operator to stop the execution of an **Auto** sequence when a failed reading is encountered. To access this option, press **SYSTEM SETUP** at the **MAIN MENU**, then press **\*MORE** at the **Select Setup Function** menu as shown:

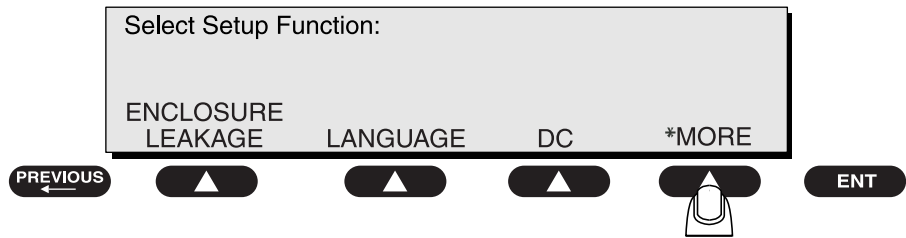

baw031f.eps

This will display the following:

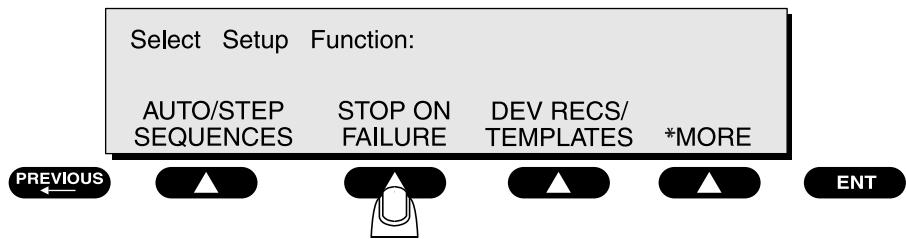

baw002f.eps

- Press **YES** or **NO** at the following menu:

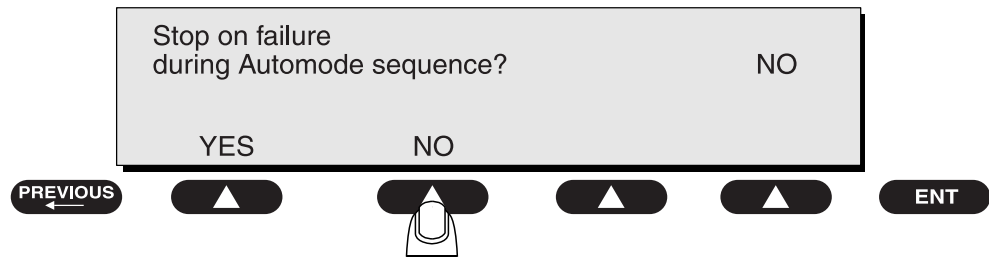

baw022f.eps

- If **YES** is selected: During an **Auto** sequence, when a reading is taken that is outside the limit for the current test, the sequence will stop and a “UNIT FAILED” message will appear with an error beep. Pressing any key will put the operator in **Manual** mode at the test during which the failure had occurred.

When a test is executed in an **Auto** sequence that utilizes multiple lead types (Insulation Resistance, Patient Leakage, Patient Auxiliary Current, or Mains on Applied Part), the 601PROXL will cycle through all of the leads prior to determining whether a limit has been exceeded. If a failure is detected, the operator will be placed in **Manual** mode at the failed test. The outlet configuration will be that of the failed condition. If the test uses applied parts, the applied part lead will be the last one tested, which is not necessarily the lead that failed.

☛ **Note: Stop on Failure** does not apply to Accessible Voltage and Accessible Leakage tests for IEC 1010.

- If **NO** is selected: The **Auto** sequence will execute until completion. The Pass/Fail determination is performed when all tests are completed.

**Default Setting:**            **No**

## 12. Configuring for Device Records or Templates<sup>1</sup>

To speed up the process of entering test variables into the 601 Pro before executing the tests, Device Records and Templates are available to store these variables for quick recall.

Device Records store test variables for each specific piece of equipment to be tested. These records not only store test variables, but specific equipment information such as serial number, control number and location of each device tested as well. Templates on the other hand, do NOT store the specific equipment information, but require this information to be keyed in at the end of each test for the test report when running an AUTO/STEP sequence.

Up to a combined total of 1000 Device Records and Templates can reside together in the 601Pro's memory. As indicated in the table below, a Device Record is stored and recalled by the equipment control number. A Template however, is identified by its name.

All the information stored in a Device Record and a Template is listed in the following table.

Field	Device Record	Template
Field to Store by	Control Number	Name
Standard	Yes	Yes
Class and Type	Yes	Yes
Applied Current	Yes	Yes
Startup Delay	Yes	Yes
Pause Before Power Off	Yes	Yes
Power Off Delay	Yes	Yes
Number of Applied Part Leads	Yes	Yes
Applied Part Names and Types	Yes	Yes
Serial Number	Yes	No
Location	Yes	No
Device Type	Yes	Yes
Device Manufacturer	Yes	Yes
Procedure ID	Yes	Yes

The advantage of using Templates over Device Records is the reduction of 601Pro memory required to store information on the equipment tested. For instance, one template can be used to test all devices in your inventory that have the same model number or require the same test protocol. It's also easy to initiate a test sequence for devices using the same template by simply pressing YES at the "Repeat Auto/Step Sequence?" prompt.

You can print a list of Device Records or Templates by pressing PRINT LIST in the Device Record or Template Utilities.

---

<sup>1</sup> Templates are available on units operating with V2.00 and later firmware

To select between using Device Records or Templates, press **SYSTEM SETUP** at the **MAIN MENU**. Next, press **\*MORE** three times at the **Select Setup Function** to display the following menu.

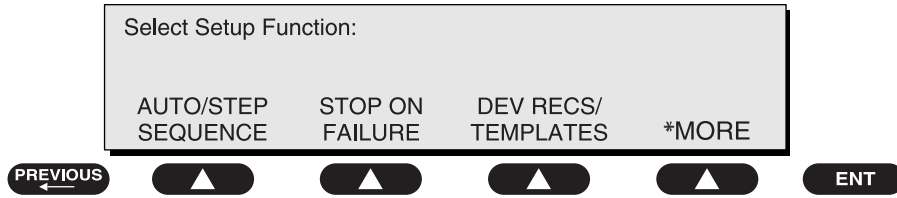

baw131f.eps

Press **DEV REC** or **TEMPLATES** to make your selection at the following menu:

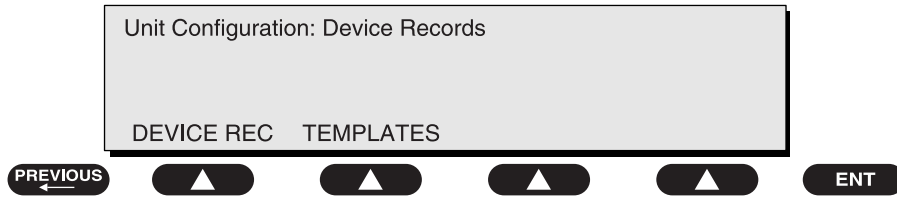

baw132f.eps

# Manual Mode

Chapter

3

This chapter provides a brief overview of 601PRO operation and describes the power-up sequence. It also explains how to set up the 601PRO's designation for the classification and type of instrument to be tested, and how to run a simple test using the applicable test standard.

1. Connecting the Device Under Test
2. The Power-Up Sequence
3. Selecting the Test Standard
4. Selecting the Class/Type
5. Saving Standard, Class, Type and Test Current
6. Using View Present Settings
7. Manual Operation

## 1. Connecting the Device Under Test

Before starting the test(s), ensure that the 601PRO and the device being tested are connected properly. Refer to *Figure 3-1* when connecting the Device Under Test (DUT) to the 601PRO. Applied Parts are optional, depending on the device being tested.



**Warning:** Before operating the 601PRO, read the *Warnings* section on pages vii through xi.

When the device and the 601PRO have been connected, power up both units. (The DUT may also be turned to ON when the **MAIN MENU** is displayed and the 601PRO outlet is OFF.)

☛ **Note:** This is good electrical practice and prevents pitting or arcing of the 601PRO outlet or the power connector of the DUT.

Once the DUT has been plugged into the 601PRO and turned on, the operator may freely move from test to test without changing the power switch of the DUT.

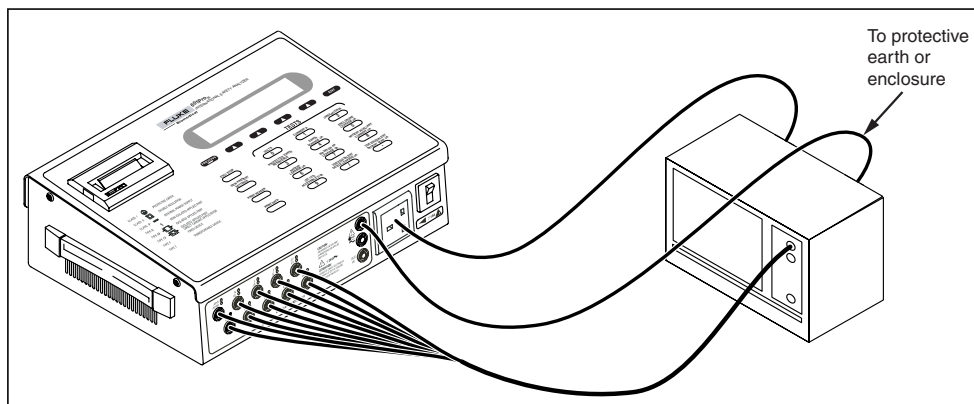

Figure 3-1: Device Under Test (DUT) Connections to the 601PRO



### 3. Selecting the Test Standard

☛ **Note:** *Chapter 8, Standards and Principles*, provides further instructions for determining and selecting the test standard.

- From the 601PRO **MAIN MENU**, press **SYSTEM SETUP**.
- At the **Select Setup Function** menu, press **TEST STANDARD**:

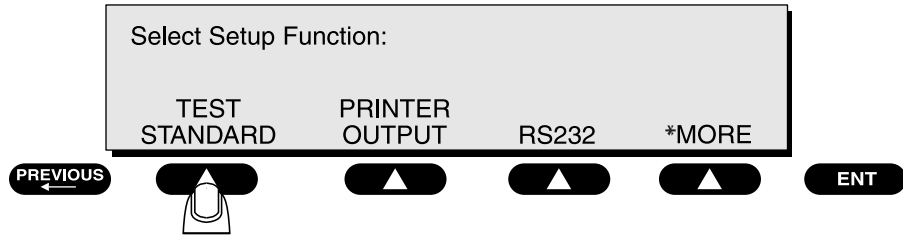

At the **Select Test Standard** menu, use one of the **SOFT KEYS** to select a test standard, or press **\*MORE** for additional options.

baw008f.eps

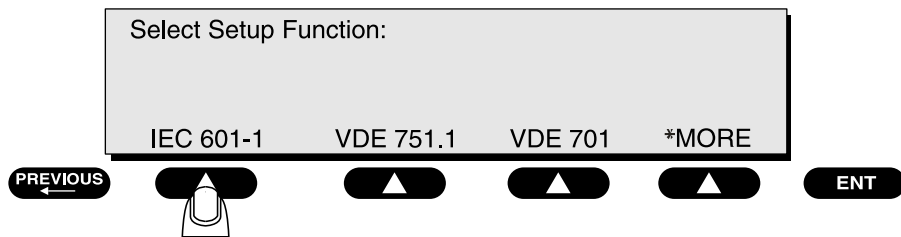

baw032f.eps

Once the selection is made, the 601PRO will automatically return to the **MAIN MENU**.

☛ **Note:** Changing the test standard may change the instrument's current Class/Type setting.

#### 4. Selecting the Class/Type

The **CLASS/TYPE** selection sets the Type of EQUIPMENT that is being tested. This affects the limits for the Protective Earth Resistance, Insulation Resistance L1, L2-Case, Earth Leakage, and Enclosure Leakage Tests.

☛ **Note:** Class/Type is not used by custom standards, and hence, is not available.

The class/type should be set to the instrument's classification and type before testing. The 601PRO defaults to the **Class/Type** setting for the most recently used test standard.







The **Class/Type** option allows the operator to choose all valid class/type selections for the present test standard. If the device under test has applied part leads, then they should be entered via the **view present settings** key. The **Class/Type** option is accessible from the **MAIN MENU**.

If the device to be tested conforms to IEC 601-1, its class/type can easily be identified by symbols marked on the instrument.

In **Manual** mode, the Test Load used for measurements is set by the test standard selection with the following exceptions:

- ⇒ The VDE Equivalent Device and VDE Equivalent Patient Leakage tests use the IEC 601-1 Test Load exclusively.
- ⇒ The Accessible Voltage and Accessible Leakage tests use the IEC 1010 Test Load exclusively. When a VDE or IEC 1010 test is selected, the Test Load is switched to the test-specific load. When a test other than a VDE or IEC 1010 is selected, the Test Load specified by the current test standard (using the **Select Test Standard** menu) is used.

Determine the class/type for the instrument by using the following chart:

Class/Type Definitions		
<b>Class I</b>		Protective Earth. (There is no symbol for Class I instruments. However, they generally have a protective earth terminal.)
<b>Class II</b>		Double insulation (all plastic case)
<b>Class IP</b>		Internal Power Supply
<b>Type B</b>		Non-Isolated Applied Part
<b>Type BF</b>		Isolated Applied Part
<b>Type CF</b>		Isolated Applied Part, suitable for direct cardiac application
<b>Type F</b>		Fixed Device
<b>Type T</b>		Transportable Device

- At the 601PRO **MAIN MENU**, press **CLASS/TYPE**:

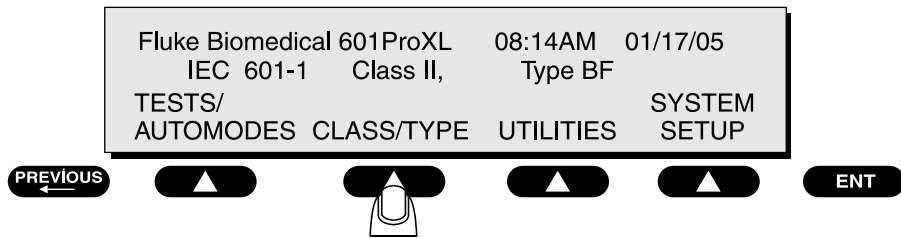

Press the **SOFT KEY** below the desired **CLASS/TYPE**, or press **\*MORE** for additional options.

baw005f.eps

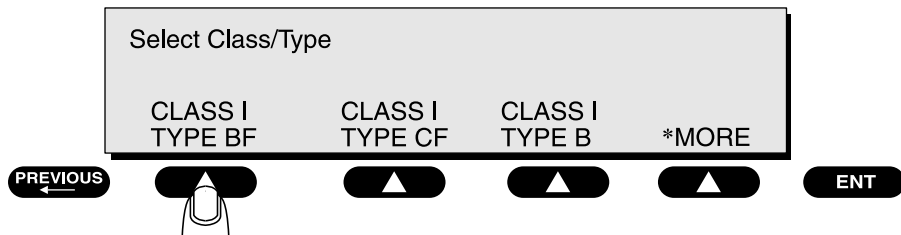

☛ **Note:** When the **CLASS/TYPE** is changed, the lead types are not changed.

baw006f.eps

☛ **Note:** Once the selection is made, the 601PRO will automatically return to the **MAIN MENU**.

## 5. Saving Standard, Class, Type and Test Current

The Standard, Class, and Type can be saved in non-volatile memory by running a manual test that is applicable to that configuration. For example, make a selection under **VIEW PRESENT SETTINGS** menu. Next, press the **0** button to run a mains Voltage test. Press **PREVIOUS** to end the test and now the parameter will be saved. It will remain as the default after cycling power off and back on.

☛ **Note:** With units operating with V2.00 or later firmware, the Protective Earth Resistance Test Current will also be saved as above by running a manual test.

## 6. Using View Present Settings

- The **view present settings** key allows the operator to inspect or alter the currently selected test standard, class/type, or current source. This is also the only way to edit the Lead selection (Applied Part Type).

From the **MAIN MENU** or the manual Patient Auxiliary Current test:

- Press the **view present settings** key from the top panel.

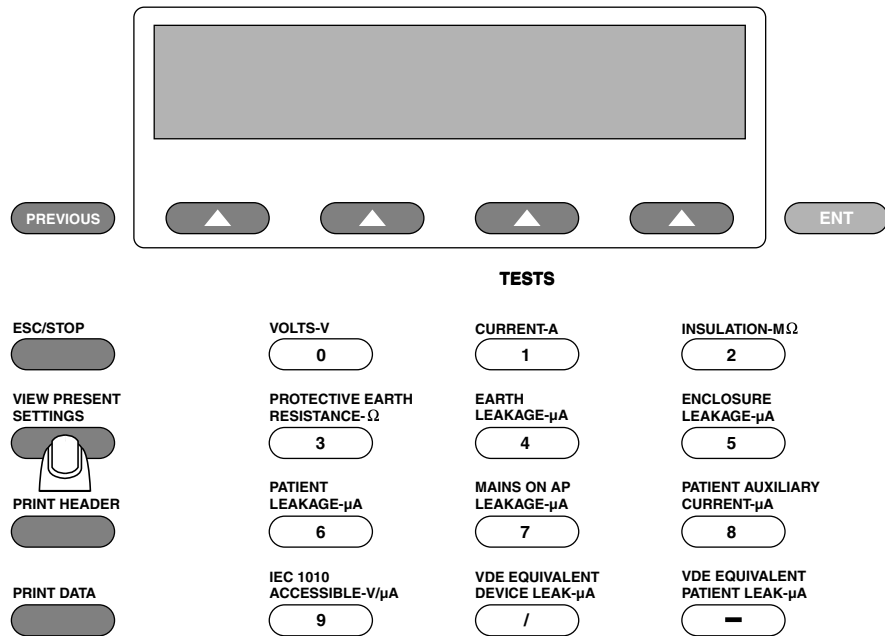

baw153f.eps

To change the test standard, press **SELECT STANDARD**:

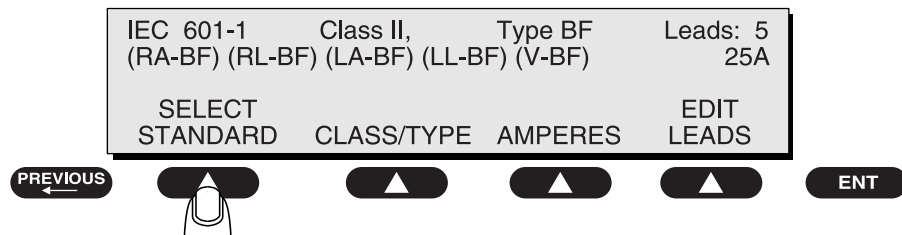

baw034f.eps

- Use a **SOFT KEY** to select a test standard, or press **\*MORE** for further options:

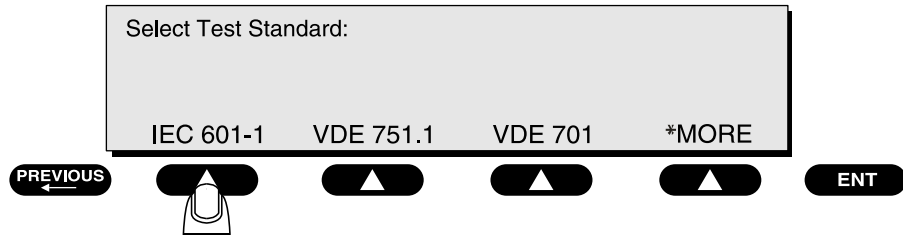

baw158f.eps

- **Note:** Altering the test standard may change the Protective Earth Resistance current setting.
- **Note:** Once the selection is made, the 601PRO will automatically return to the **MAIN MENU**.

- To change the class/type, press the **view present settings** key, and press **CLASS/TYPE** at the following menu:

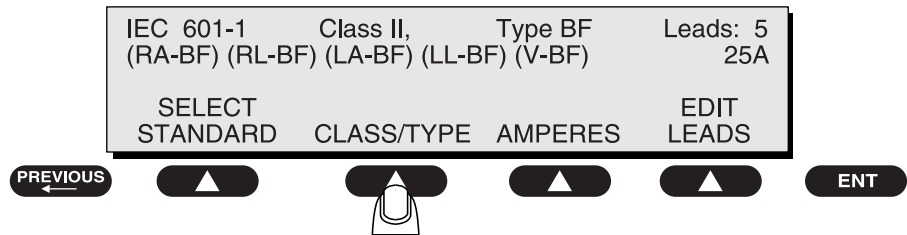

baw035f.eps

- Use a **SOFT KEY** to select a class/type, or press **\*MORE** for further options:

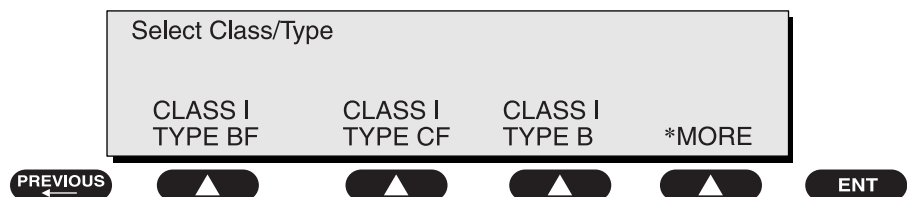

baw033f.eps

- **Note:** When the **CLASS/TYPE** is changed, the LEAD types are NOT changed.
- **Note:** Once the selection is made, the 601PRO will automatically return to the **MAIN MENU**.

To choose the current source to be used for the Protective Earth Resistance test, press the **view present settings** key, and press **AMPERES** at the following menu:

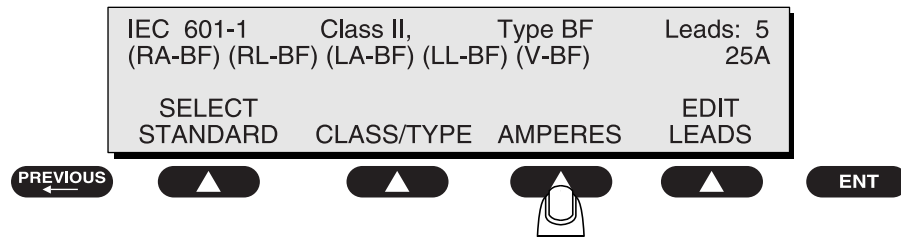

The test current displayed in the upper right corner will toggle between the available currents. baw036f.eps

- Press enter to return to the **MAIN MENU**.

---

## Lead Type Definitions

The **CLASS/TYPE** selection sets the Type of EQUIPMENT that is being tested. This affects the limits for the Protective Earth Resistance, Insulation Resistance L1, L2-Case, Earth Leakage, and Enclosure Leakage Tests.

When Applied Part Types are defined, this affects the limits as well as which tests are being performed on each of the individual leads. The operator should consider the following possible scenarios when defining Applied Part Types:

### CONDITION 1:

If **ALL** of the Applied Parts are defined with the **SAME** Type as the EQUIPMENT Type, then the leads will be tested **TOGETHER**.

### CONDITION 2:

If **ALL** of the Applied Parts are defined with the **SAME** Type, but with a different type than the EQUIPMENT Type, then the Applied Parts will be tested **INDIVIDUALLY**.

**CONDITION 3:**

If at least one Applied Part is defined with a ***DIFFERENT*** Type than any of the leads or the EQUIPMENT Type, then the Applied Parts will be tested ***INDIVIDUALLY***.

1. To view or change the lead types, press the **view present settings** key while at the **MAIN MENU**.
2. Press **EDIT LEADS** at the following menu:

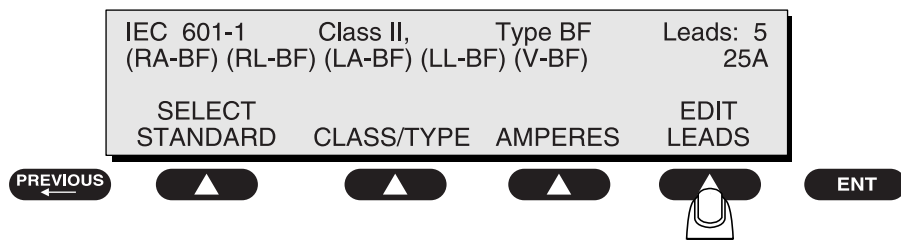

baw037f.eps

3. Enter the **Number of Applied Part Leads** using the numeric keys:

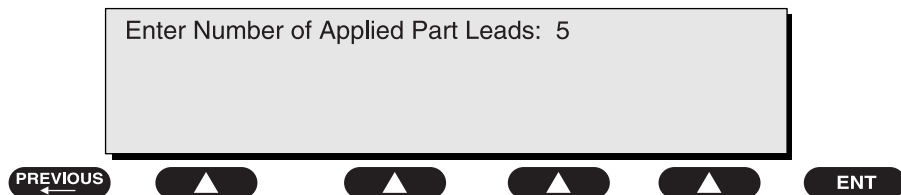

baw038f.eps

This selection allows the user to define the number of applied parts to be tested during the Mains on Applied Part, Insulation Resistance, Patient Auxiliary Current, and Patient Leakage tests. This screen will only appear when the selected test standard is one of the following:

- ◆ IEC 601-1
- ◆ HEI 95
- ◆ Custom 1-4\*
- ◆ AAMI\*
- ◆ AS/NZS 3551

Press **enter**.

**\*Note:** When using the AAMI or Custom test standard, only the applied parts can be assigned; the Type cannot be changed.

4. Make lead type assignments at the **Define Lead and Select Type** menu:

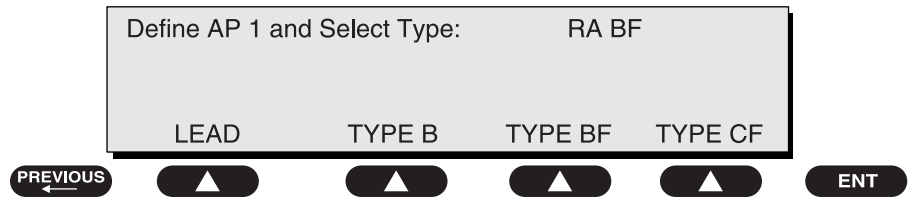

baw039f.eps

This selection allows the operator to define the Types for each of the applied parts during the following tests: Mains on Applied Part, Insulation Resistance – Applied Part, Patient Leakage, and Patient Auxiliary Current. The Limits applied to the leads will be set based on the Type selected.

Use the following procedure to test a defibrillator with two paddles, Type BF, and three ECG leads, RA, LA and LL, all of which are Type CF. (This is an example of Condition 3 described on page 3-10.)

Assuming that the ECG leads will be connected to the 601PRO applied part terminals with the identical names, the paddles would have to be connected to the RL and any V terminal. Define the lead types using the following steps:

1. The first lead that appears for definition is RA. Since RA is Type CF, press **TYPE CF**:

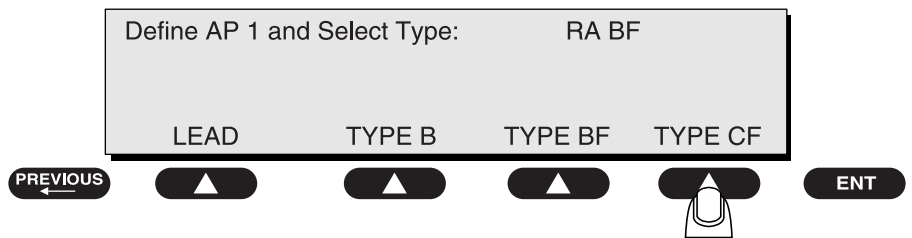

baw040f.eps

Press **enter** to advance to the next lead (RL).

2. Since RL is Type BF, press **TYPE BF**:

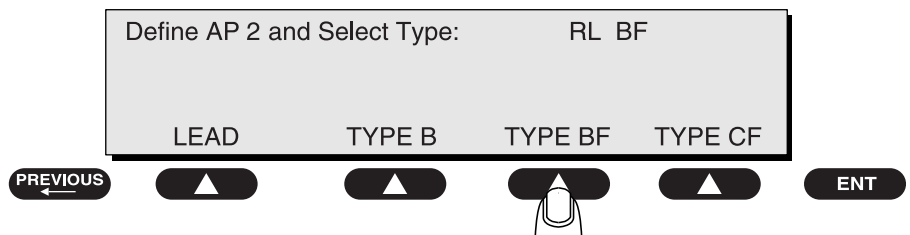

baw041f.eps

Press **enter** to advance to the next lead (LA).

3. Since LA is Type CF, press **TYPE CF**.

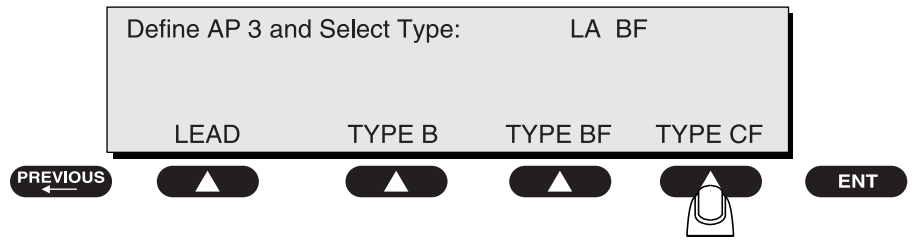

baw042f.eps

Press **enter** to advance to the next lead (LL).

4. Since LL is Type CF, press **TYPE CF**.

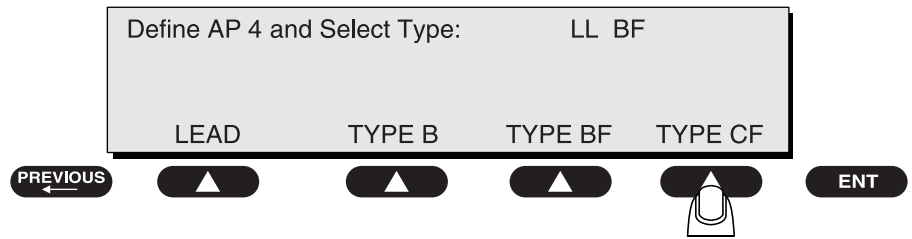

baw043f.eps

Press **enter** to advance to the next lead (V1-V6).

5. Since the V lead is Type BF, press **TYPE BF**.

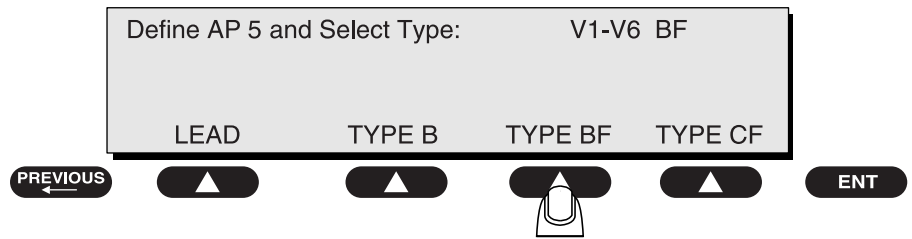

baw044f.eps

- ☛ **Note:** The applied parts are always assigned left to right, beginning with the top row.

## 7. Manual Operation

The 601PRO can be used to perform individual tests manually (**Manual** mode) without the need to perform an automated sequence (**Auto** mode).

- Note:** In *Chapter 8, Standards and Principles*, a table of limits for each test standard, Class, Type, and DUT Outlet configuration is available. In **Manual** mode, tests that are not part of the currently selected standard will operate, but the limits will be displayed as **Inv** (invalid).

The operator may perform any of the available tests by selecting **MANUAL** from the **TESTS/AUTOMODES** option. The following will be displayed:

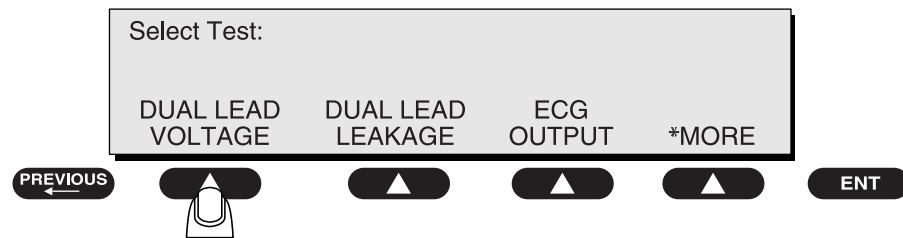

Press the **\*MORE** key to view all possible tests.

baw045f.eps

- Note:** The IEC-1010 Accessible Leakage Current and Accessible Voltage tests appear in the menus only when the IEC-1010 test standard is the currently selected standard. Similarly, the VDE Equivalent Device Leakage Current and VDE Equivalent Patient Leakage Current appear in the menus only when the appropriate VDE test standard is the currently selected standard.

When in the **MAIN MENU** or any manual test, the operator may also select a manual test by pressing the **test-shortcut** keys as indicated in the following table.

Test-Shortcut Key	Manual Test Selected
0	Mains Voltage and Dual Lead Voltage
1	Current Consumption
2	Insulation Resistance
3	Protective Earth Resistance
4	Earth Leakage Current
5	Enclosure Leakage Current
6	Patient Leakage Current
7	Mains on Applied Part Leakage Current
8	Patient Auxiliary Current
9	IEC 1010 Accessible Voltage and IEC 1010 Accessible Leakage Current
/	VDE Equivalent Device Leakage Current
-	VDE Equivalent Patient Leakage Current

In addition to the above tests, Dual Lead Leakage and ECG Output can be accessed through the manual test menus by pressing **TESTS/AUTOMODES**, then **MANUAL**, then **\*MORE** until the tests are displayed. These tests are **not** accessible from the **test-shortcut** keys.

### Additional Features

- From the **MAIN MENU** or any manual test, press the **print header** key to print a test header to the selected printer.
- When the **MAIN MENU** is displayed, the DUT outlet is OFF (L1, L2 and Earth are open).
- The current standard is displayed on the **MAIN MENU** and may be changed by selecting **SYSTEM SETUP** then **TEST STANDARD**, or by pressing the **view present settings** key. Refer to *Chapter 8, Standards and Principles*, for details.
- The current class/type is displayed on the **MAIN MENU** and may be changed by selecting **CLASS/TYPE** or by pressing the **view present settings** key. Refer to page 3-8 in this chapter, or *Chapter 2, Setting Up the 601PRO*, for details.

- In tests where the condition of the DUT outlet can be changed, its status is shown on the display and may be modified by pressing the appropriate **SOFT KEY** on the 601PRO. The following menu is displayed:

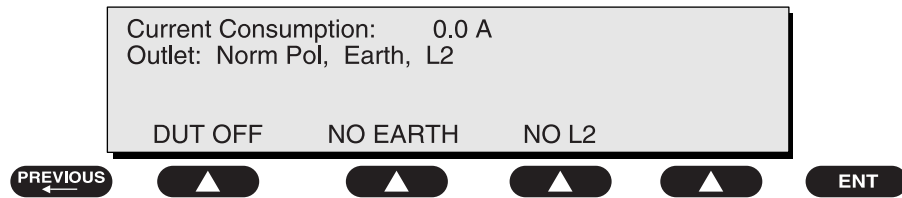

- SOFT KEY 1** cycles the polarity from *Normal Polarity* to *DUT Off* to *Reverse Polarity*, or from *Reverse Polarity* to *DUT Off* to *Normal Polarity*. baw046f.eps
  - SOFT KEY 2** changes the earth line from *Earth* (closed earth) to *No Earth* (open earth).
  - SOFT KEY 3** changes the L2 line from *L2* (closed L2) to *No L2* (open L2).
- In all modes, when changing tests, the configuration of the DUT outlet will not change unless the present condition is invalid for the new test selected. For example, if L2 is open in a patient leakage test, and an enclosure leakage test is selected, L2 will remain open. If a Mains On Applied Part test were selected instead of Enclosure Leakage, L2 would automatically close, because its connection is required for this test.
- The V1 through V6 Applied Part/ECG terminals on the 601PRO control panel are all internally connected together and act as a single applied part.
- In **Manual** and **Step** modes, the insulation resistance test is performed for one minute only. In **Auto** mode, the insulation resistance test is performed for 12 seconds.
- The **enter** key advances to the next menu or saves/selects options.
- The **print data** key sends displayed test data to the printer.
- The **previous** key returns the operator to the previous screen.
- The **esc/stop** key discontinues the current test and returns the operator to the **MAIN MENU**.



**Important:** *Inv (Invalid)* will appear next to the reading if the selected test is not applicable to the test standard and class/type chosen, and outlet fault conditions are present.

### Shortcut Key 0: Mains Voltage Test and Dual Lead Voltage Test

This test can be initiated either from the **test-shortcut** keys or the **MAIN MENU**. The Mains Voltage Test measures and displays the Mains voltages from L1 to Earth, L2 to Earth, and L1 to L2. The Dual Lead Voltage Test measures the voltage between the RED and BLACK inputs.



**Important:** Power to the 601PRO front panel outlet is **off** during the Mains Voltage Test, and **on** during the Dual Lead Voltage Test.

To measure the mains voltage (L1-EARTH, L2-EARTH, L1-L2), press **shortcut key 0** or press **TESTS/AUTOMODES** from the **Main Menu**, then **MANUAL** and then select **MAINS VOLTAGE**.

- The **Mains Voltage** test appears on the display, and the test begins immediately. Display voltages are continuously updated until another test is selected.

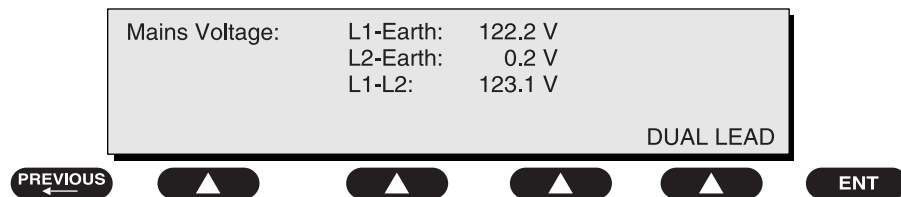

- Press the **print data** key at any time to generate a printout of the latest measurement(s).
- Press **previous** or **esc/stop** at any time to return to the **MAIN MENU**.

baw047f.eps

### Dual Lead Voltage Test

To initiate the Dual Lead Voltage test, select **DUAL LEAD** from the **Mains Voltage** test, or select the Dual Lead Voltage Test from the **MAIN MENU**.

The **Dual Lead Voltage** test appears, and the test begins immediately. Display values are continuously updated until another test is selected.

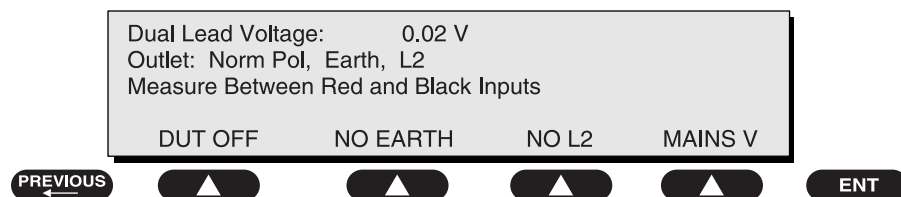

To take a **Dual Lead Voltage** measurement:

- Apply the voltage to be measured to the RED and BLACK terminals.
- Press the **print data** key at any time to generate a printout of the latest measurement(s).

baw048f.eps

Modify the configuration of the front panel outlet by pressing the appropriate **SOFT KEY** on the 601PRO:

- **SOFT KEY 1:** Toggles the polarity from *Normal* to *Off* to *Reverse* Polarity.
- **SOFT KEY 2:** Changes the earth line from *Earth* (closed earth) to *No Earth* (open earth).
- **SOFT KEY 3:** Changes the L2 line from *L2* (closed L2) to *No L2* (open L2).
- **SOFT KEY 4:** Returns to the **Mains Voltage** menu.

### Shortcut Key 1: Current Consumption Test

To measure the current (in amperes) flowing in L2 of the DUT, press **shortcut key 1**, or select the Current Consumption Test by pressing **TESTS/AUTOMODES**, then **MANUAL**, then **\*MORE** until the test is displayed.

To measure the current consumption:

- From the **MAIN MENU**, or with the outlet **unpowered**, plug the DUT into the 601PRO front panel outlet, and turn on the device.
- Press **shortcut key 1**. The **Current Consumption** test is displayed, and the test begins immediately. Display values are continuously updated until another test is selected.

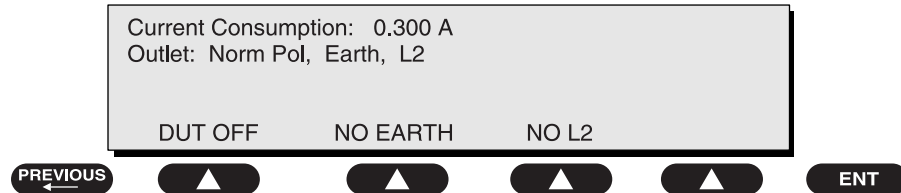

- Modify the configuration of the front panel outlet by pressing the appropriate **SOFT KEY** on the 601PRO.
- **SOFT KEY 1** toggles the DUT outlet Polarity from Normal to Off to Reverse.
- **SOFT KEY 2** toggles the DUT outlet from Earth to No Earth.
- **SOFT KEY 3** toggles the DUT outlet from L2 to No L2.
- Press the **print data** key at any time to generate a printout of the latest measurement(s).

baw049f.eps

## Shortcut Key 2: Insulation Resistance Test

The Insulation Resistance Tests measure (in Megohms) the resistance from DUT outlet L1 and L2 to DUT Earth, or from applied parts to DUT Earth. The measurement is taken with a test voltage of 500 Volts DC. The test will not begin until **START TEST (SOFT KEY 1)** is pressed. Once running, display values are updated continuously and the unit will beep repeatedly as long as a test is active. The test lasts for 60 seconds in **Manual** and **Step** modes, and 6 seconds when running in **Auto** mode unless the operator terminates the test by pressing the **STOP TEST (SOFT KEY 1)** or the **esc/stop** key.



**Important:** *This test is acceptable per IEC 601-1 for non-manufacturers' retesting of devices. The standard specifically indicates that this test **should not be carried out at the full voltage** used by manufacturers to stress the DUT.*

*The front panel outlet is turned **off** during this test. The following conditions apply:*

- L1 and L2 Open with 500VDC applied between L1 and L2 to Earth



**Important:** *A 2-beep-per-second signal indicates high voltage present at the DUT Outlet and at the applied part terminals. In Auto Step tests, the applied parts insulation resistance test will apply high voltage to all*

To perform an **Insulation Resistance** test (L1 and L2 to Case) using the **shortcut** keys:

- From the **MAIN MENU**, or with the outlet **unpowered**, plug the DUT into the 601PRO front panel outlet with the DUT's power switch ON.
- Attach the device's applied parts to the 601PRO's applied part terminals.
- Press **shortcut key 2**. The **Insulation Resistance** test is displayed:

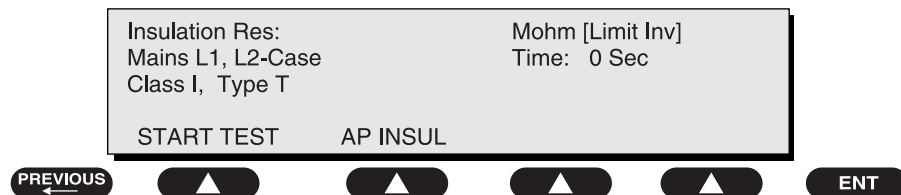

- Press **START TEST** to start running the test.
- **SOFT KEY 1** starts or stops the test.
- **SOFT KEY 2** changes the test to AP to Insulation Resistance.
- The unit will beep repeatedly as long as the test is active.
- Press **STOP TEST soft key** to terminate the test.
- Press the **print data** key at any time to generate a printout of the latest measurement(s).

baw050f.eps

To perform an **Insulation Resistance Applied Part-to-Case** test, press **AP INSUL** while the **Insulation Resistance** test is displayed. In this test, 500 VDC is applied between (one or all in common) applied parts and the DUT Earth.

- Attach the device's applied parts to the 601PRO's applied part terminals.
- Press **APPLIED PART (SOFT KEY 4)** to select the applied part(s) to be tested.
- Press **START TEST** to begin the test.

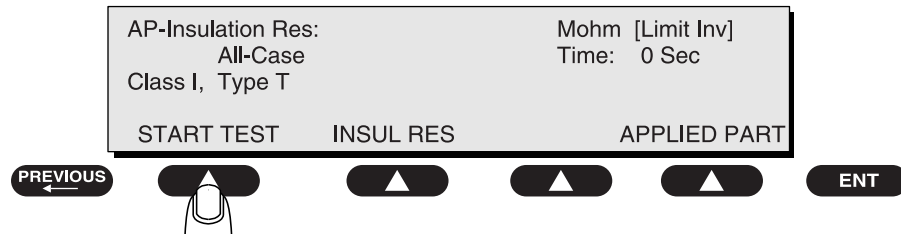

baw051f.eps

- ⇒ **SOFT KEY 1** starts or stops the test.
- ⇒ **SOFT KEY 2** changes the test to Insulation Resistance.
- ⇒ **SOFT KEY 4** toggles the applied part from:
  - ALL to Case
  - RA to Case
  - RL to Case
  - LA to Case
  - LL to Case
  - V1-V6 to Case
- ⇒ The unit will beep repeatedly as long as the test is active.
- ⇒ Press **STOP TEST (SOFT KEY 1)** to terminate the test.
- Press the **print data** key at any time to generate a printout of the latest measurement(s).



**Important:** *If all of the applied parts correspond to the instrument type, the applied parts will be tied together and one reading will be taken. If any of the applied parts differ from the instrument type, all applied parts will be tested individually, based on the **type** of applied part. This applies to **Auto and Step modes only.***

### Shortcut Key 3: Protective Earth Resistance Test

Protective Earth Resistance is measured using the RED test lead attached to the DUT Protective Earth terminal or enclosure. Select the test current by pressing **SOFT KEY 3** to toggle between **1AMP**, **10AMP**, and **25AMP**. The front panel outlet power is turned **off** for this test. The following conditions apply:

- L1 and L2 Open

☛ **Note:** Calibrate the test leads if performing a protective earth resistance test for the first time with a unit or when using a new set of leads. Also calibrate the leads if the unit does not read zero when the test lead is connected between the RED and GREEN input jacks and a measurement is taken.

It is recommended that calibration be performed at 1 and 25 Amps.

☛ **Note:** Only use Fluke Biomedical-supplied test leads (PN 2213252 or 2391723), or leads rated for 32 Amps/1000 Volts with the Protective Earth Resistance Test.

To calibrate the test leads:

- First select the test current that will be used for performing the Protective Earth Resistance test by pressing **AMPERES (SOFT KEY 3)**.
- Connect the test lead(s) between the RED input jack and the GREEN input jack.
- Press **CAL LEADS**. The 601PRO will measure the lead resistance, and if less than 0.150 Ohms, it will store the reading and subtract it from all earth resistance readings taken at the calibrated current.

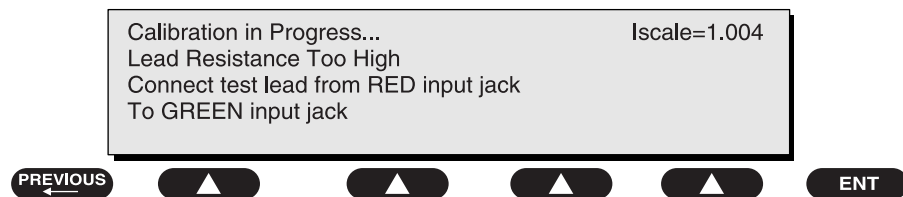

baw052f.eps

If the leads have too much resistance (higher than 0.150 Ohms) or are not properly attached, the following **Calibration** screen will appear:

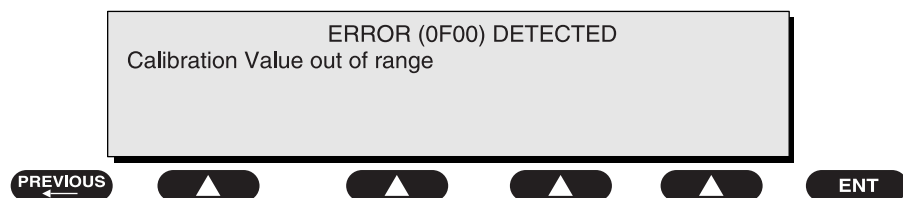

baw053f.eps

- ☛ **Note:** If the calibration fails, the previously stored readings will be used until a passing calibration has occurred.

To perform a Protective Earth Resistance test:

- From the **MAIN MENU**, or with the outlet unpowered, plug the DUT into the 601PRO front panel outlet.
- Attach the 601PRO RED input lead to the device's Protective Earth terminal or an exposed metal area.
- Press **shortcut key 3**. The **Protective Earth Resistance** test is displayed.
- Press **SOFT KEY 3** to select a test current (**1AMP**, **10AMP**, or **25AMP**). The selected test current is displayed in the upper right corner of the display.

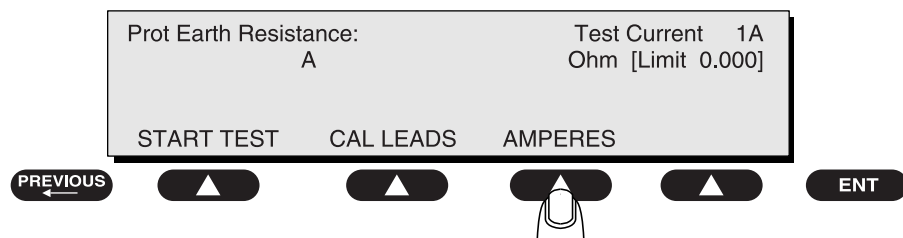

baw054f.eps

- Press **START TEST** to start the test. The test current is applied while resistance and current readings are taken. This takes approximately 5 seconds.

- ☛ **Note:** When "**Over**" is displayed for Ohms, this signifies that a valid measurement was not obtained because either an open connection was detected or that the measurement was not within range. Readings greater than 9.999 Ohms will be displayed as **Over**.

- Press the **print data** key at any time to generate a printout of the latest measurement(s).



**Warning:** *During Earth Resistance testing, the DUT must be plugged into the 601PRO front outlet. If the DUT fails Earth Resistance, discontinue tests and label the device defective.*

To perform a **Point-to-Point Resistance** test:

- Attach the RED lead to the RED input terminal and the BLACK lead to the GREEN terminal.
- Place unknown R between the two leads.
- Press **START TEST (SOFT KEY 1)**.

#### Shortcut Key 4: Earth Leakage Test

Run an **Earth Leakage** test on the device being tested before performing any other leakage tests.

Leakage current is measured the following ways:

- ◆ Earth Leakage Current, leakage current measured through DUT outlet Earth
- ◆ Earth Leakage Current AP-EARTH (ALL Applied Parts connected to Earth), leakage current measured through DUT outlet Earth

There is no need to attach a test lead; the 601PRO automatically connects the measuring device internally.

The following outlet conditions apply when performing this test:

- ⇒ Normal Polarity, Earth Open, Outlet ON
- ⇒ Normal Polarity, Earth Open, L2 Open, Outlet ON
- ⇒ Reversed Polarity, Earth Open, Outlet ON
- ⇒ Reversed Polarity, Earth Open, L2 Open, Outlet ON

To perform the **Earth Leakage** test:

- From the **MAIN MENU**, or with the outlet unpowered, plug the DUT into the 601PRO front panel outlet, and turn on the device.
- Attach the device's applied parts to the 601PRO applied part terminals if applicable.
- Press **shortcut key 4**. The **Earth Leakage** test appears on the display, and the test begins immediately:

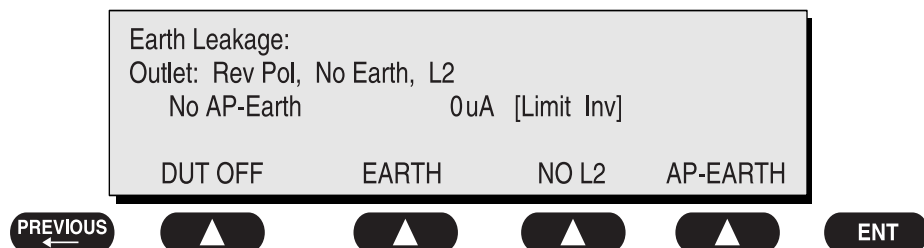

baw055f.eps

- ⇒ **SOFT KEY 1** toggles the DUT outlet Polarity from Normal to Off to Reverse.
- ⇒ **SOFT KEY 2** toggles the DUT outlet from Earth to No Earth.
- ⇒ **SOFT KEY 3** toggles the DUT outlet from L2 to No L2.
- ⇒ **SOFT KEY 4** toggles the AP to Earth to No AP to Earth.
- Press the **print data** key at any time to generate a printout of the latest measurement.

### **Shortcut Key 5: Enclosure Leakage Test**

Run an Enclosure Leakage test on the device being tested before performing any leakage tests.

Leakage current is measured the following ways:

- ◆ Enclosure Leakage, leakage current measured from RED input jack to DUT outlet Earth.
- ◆ Enclosure Leakage AP-EARTH (ALL Applied Parts connected to Earth), leakage current measured from RED input jack to DUT outlet Earth.

The following outlet conditions apply when performing this test:

- ⇒ Normal Polarity, Earth Open, Outlet ON
- ⇒ Normal Polarity, Outlet ON
- ⇒ Normal Polarity, L2 Open, Outlet ON
- ⇒ Reversed Polarity, Outlet ON
- ⇒ Reversed Polarity, Earth Open, Outlet ON
- ⇒ Reversed Polarity, L2 Open, Outlet ON

To perform an **Enclosure Leakage** test in a single lead mode:

- From the **MAIN MENU**, or with the outlet unpowered, plug the DUT into the 601PRO front panel outlet, and turn on the device.
- Attach the RED test lead from the 601PRO to the device. A bare exposed metal area should be selected.
- Attach the device's applied parts to the 601PRO applied part terminals if applicable.

- Press **shortcut key 5**. The **Enclosure Leakage** test appears on the display, and the test begins immediately.

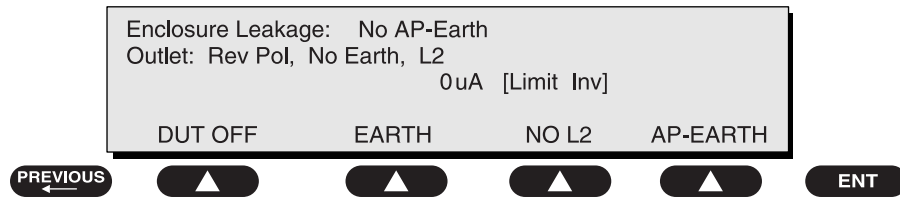

- Press **SOFT KEYS 1-4** to select leakage tests:
  - ⇒ **SOFT KEY 1** toggles the DUT outlet Polarity from Normal to DUT Off to Reverse, or from Reverse to DUT Off to Normal.
  - ⇒ **SOFT KEY 2** toggles the DUT outlet from Earth to No Earth.
  - ⇒ **SOFT KEY 3** toggles the DUT outlet from L2 to No L2.
  - ⇒ **SOFT KEY 4** toggles the AP to Earth to No AP to Earth.
- Press the **print data** key at any time to generate a printout of the latest measurement.

baw056f.eps

### **Shortcut Key 6: Patient Leakage Current Test (IEC 601-1 or VDE 751-1 Test Standard)**

Patient leakage currents are measured between a selected applied part and mains earth. All measurements may have either a true RMS or a DC-only response.

- Perform a calibration from the **Mains on Applied Part** menu.

The following outlet conditions apply when performing this test:

- ⇒ Normal Polarity, Earth Open, Outlet ON
- ⇒ Normal Polarity, Outlet ON
- ⇒ Normal Polarity, L2 Open, Outlet ON
- ⇒ Reversed Polarity, Outlet ON
- ⇒ Reversed Polarity, Earth Open, Outlet ON
- ⇒ Reversed Polarity, L2 Open, Outlet ON

To perform a **Patient Leakage Current** test using the **test-shortcut** keys:

- From the **MAIN MENU**, or with the outlet unpowered, plug the DUT into the 601PRO front panel outlet, and turn on the device.
- Attach the applied parts to the 601PRO's applied part terminals.
- Press **shortcut key 6**. The **Patient Leakage** test is displayed, and the test begins immediately.

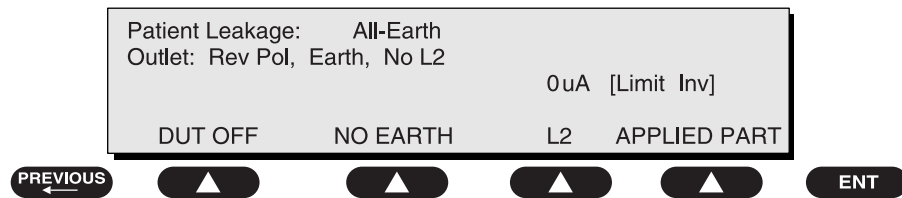

baw057f.eps

⇒ **SOFT KEY 1** toggles the DUT outlet Polarity from Normal to DUT Off to Reverse Polarity, or Reverse to DUT Off to Normal Polarity.

⇒ **SOFT KEY 2** toggles the DUT outlet from Earth to No Earth.

⇒ **SOFT KEY 3** toggles the DUT outlet from L2 to No L2.

⇒ **SOFT KEY 4** toggles the applied part from:

- ALL to Earth (RMS)
- RA to Earth (RMS)
- RL to Earth (RMS)
- LA to Earth (RMS)
- LL to Earth (RMS)
- V1-V6 to Earth (RMS)
- ALL to Earth DC
- RA to Earth DC
- RL to Earth DC
- LA to Earth DC
- LL to Earth DC
- V1-V6 to Earth DC

☛ **Note:** If the current test standard being used does not include Patient Leakage DC readings, or the DC option is not enabled, then DC readings will not be available through the **APPLIED PART SOFT KEY** selections. Refer to *Chapter 8, Standards and Principles*.

- Press **APPLIED PART (SOFT KEY 4)** at any time to select the desired applied part leakage current:
- Modify the configuration of the front panel outlet by pressing the appropriate **SOFT KEY** on the 601PRO.
- Press the **print data** key at any time to generate a printout of the latest measurement.



**Important:** *If all of the applied parts correspond to the instrument type, the applied parts will be tied together and one reading will be taken. If any of the applied parts differ from the instrument type, all applied parts will be tested individually, based on the **type** of applied part. This applies to **Auto and Step modes only.***

### Shortcut Key 7: Mains on Applied Part Leakage Test (IEC 601-1)

The **Mains on Applied Part** test applies a test voltage, which is 110% of the mains voltage, through a limiting resistance, to selected applied part terminals. Current measurements are then taken between the selected applied part and earth. Measurements are taken with the test voltage (110% of mains) to applied parts in the normal and reverse polarity conditions as indicated on the display.

The following outlet conditions apply when performing the **Mains on Applied Part** test:

- ⇒ Normal Polarity
- ⇒ Reversed Polarity

- **Note:** It is recommended that a leakage calibration be performed whenever the mains voltage level is changed (120 VAC to 220 VAC, or 220 VAC to 120 VAC), or when using the unit for the first time. This can be done from either of the VDE Equivalent Leakage tests or from Mains on Applied Part.

To perform the **Mains on Applied Part** test using the **test-shortcut** keys:

- From the **MAIN MENU**, or with the outlet unpowered, plug the DUT into the 601PRO front panel outlet, and turn on the device.
- Attach the applied parts to the 601PRO applied part terminals.
- Attach the red terminal lead to a conductive part on the DUT enclosure.
- Press **shortcut key 7**. The **Mains on Applied Part** test is displayed.

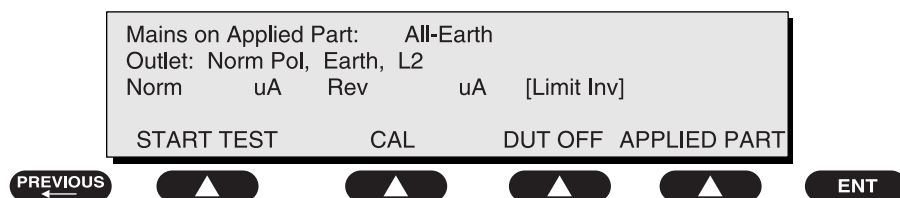

- Select the desired outlet configuration and applied part to test using the appropriate **SOFT KEYS**:
  - ⇒ **SOFT KEY 1** takes one pair of readings and displays the result.
  - ⇒ **SOFT KEY 2** allows the user to perform a calibration.
  - ⇒ **SOFT KEY 3** toggles the DUT outlet Polarity from Normal to DUT Off to Reverse Polarity, or Reverse to DUT Off to Normal Polarity.
  - ⇒ **SOFT KEY 4** toggles the applied part from:
    - ALL to Earth
    - RA to Earth
    - RL to Earth
    - LA to Earth
    - LL to Earth
    - V1-V6 to Earth
- Press **START TEST (SOFT KEY 1)** to begin the test.



**WARNING:** *High voltage is present at applied part terminals while measurements are being taken.*

- Press the **print data** key to generate a printout of the latest measurement.

To perform a calibration from the **Mains on Applied Part** test, press **CAL (SOFT KEY 2)**.

- Disconnect ALL patient leads, test leads, and DUT outlet connections.
- Press **CAL** to begin calibration, as shown:

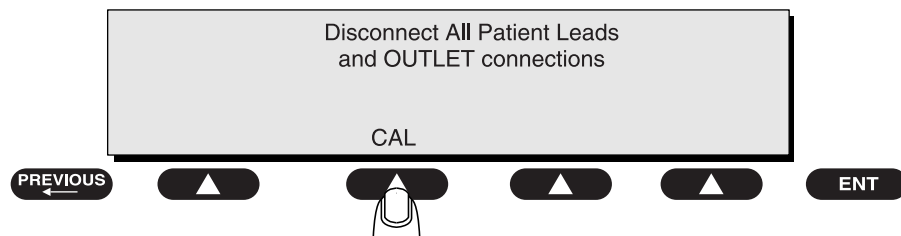

baw059f.eps

**WARNING:** *A 2-beep-per-second signal indicates high voltage present at the applied part terminals while a calibration is being performed.*



- When the calibration is finished, the **Mains on Applied Part** test will reappear.
- Note:** If the calibration fails, the previously stored readings will be used until a passing calibration has occurred. Also, the **esc/stop** key has no effect during calibration.



**Important:** *If all of the applied parts correspond to the instrument type, the applied parts will be tied together and one reading will be taken. If any of the applied parts differ from the instrument type, all applied parts will be tested individually, based on the **type** of applied part. This applies to **Auto and Step modes only**.*

### Shortcut Key 8: Patient Auxiliary Current Test

Patient Auxiliary currents are measured between any selected ECG jack and the remaining selected ECG jacks (refer to *Lead Type Definitions on page 3-9*). All measurements may have either a true RMS or a DC-only response.

The following outlet conditions apply when performing this test:

- ⇒ Normal Polarity, Earth Open, Outlet ON
- ⇒ Normal Polarity, Outlet ON
- ⇒ Normal Polarity, L2 Open, Outlet ON
- ⇒ Reversed Polarity, Outlet ON
- ⇒ Reversed Polarity, Earth Open, Outlet ON
- ⇒ Reversed Polarity, L2 Open, Outlet ON

☛ **Note:** If the current test standard is IEC 1010, then the Patient Auxiliary Current test will not be available. Refer to *Chapter 8, Standards and Principles*.

To perform a **Patient Auxiliary Current** test:

- From the **MAIN MENU**, or with the outlet unpowered, plug the DUT into the 601PRO front panel outlet, and turn on the device.
- Attach the patient leads to the 601PRO ECG jacks.
- Define the Lead Types from the View Settings Option (refer to: *Lead Type Definitions* in Section 5 of this chapter).
- Press **shortcut key 8**. The **Patient Auxiliary Current** test is displayed, and the test begins immediately. Display values are continuously updated until another test is selected.

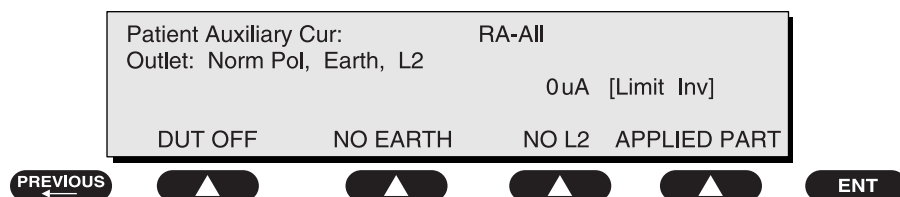

- Press **SOFT KEYS 1-4** to select leakage tests:
  - ⇒ **SOFT KEY 1** toggles the DUT outlet Polarity from Normal to DUT Off to Reverse Polarity, or Reverse to DUT Off to Normal Polarity.
  - ⇒ **SOFT KEY 2** toggles the DUT outlet from Earth to No Earth.
  - ⇒ **SOFT KEY 3** toggles the DUT outlet from L2 to No L2.
  - ⇒ **SOFT KEY 4** toggles the applied part from:
    - RA to ALL (RMS)
    - RL to ALL (RMS)
    - LA to ALL (RMS)
    - LL to ALL (RMS)
    - V1-V6 to ALL (RMS)
    - RA to ALL DC
    - RL to ALL DC
    - LA to ALL DC
    - LL to ALL DC
    - V1-V6 to ALL DC
  
- ☛ **Note:** If the current test standard being used does not include Patient Auxiliary Current DC readings, or the DC option is not enabled, then DC readings will not be available through the **APPLIED PART SOFT KEY** selections. Refer to *Chapter 8, Standards and Principles*.
  
- Press **APPLIED PART (SOFT KEY 4)** at any time to select the desired applied part leakage current:
- Modify the configuration of the front panel outlet by pressing the appropriate **SOFT KEY** on the 601PRO:
- Press the **print data** key at any time to generate a printout of the latest measurement.

**Shortcut Key 9: IEC 1010 Accessible Voltage/Leakage Test**

The Accessible Voltage and Leakage Tests are both accessible using Shortcut Key 9. The tests cannot be selected from the **Manual** menu unless the IEC 1010 test standard is selected.



**Important:** *The Accessible Voltage and Leakage test uses the IEC 1010 Test Load exclusively. This is true no matter what the currently defined test standard is.*

**Accessible Voltage**

Accessible Voltage measurements are taken from the RED input lead referenced to the Protective Earth terminal on the Mains Inlet. Accessible Voltage cannot be selected from the **Manual** menu unless the IEC 1010 test standard is selected.

The following outlet conditions apply when performing this test:

- ⇒ Normal Polarity, Earth Open, Outlet ON
- ⇒ Normal Polarity, Outlet ON
- ⇒ Normal Polarity, L2 Open, Outlet ON
- ⇒ Reversed Polarity, Outlet ON
- ⇒ Reversed Polarity, Earth Open, Outlet ON
- ⇒ Reversed Polarity, L2 Open, Outlet ON

To measure Accessible Voltage using the **test-shortcut** keys:

- From the **MAIN MENU**, or with the outlet unpowered, plug the DUT into the 601PRO front panel outlet, and turn on the device.
- Attach the RED lead to exposed metal on the enclosure of the DUT.
- Press **shortcut key 9**. The **Accessible Voltage** test appears on the display, and the test begins immediately. Display values are continuously updated until another test is selected.

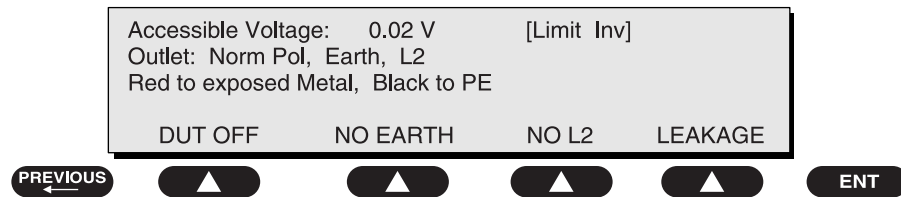

baw061f.eps

- Press **SOFT KEYS 1-3** to select the desired outlet configuration:
  - ⇒ **SOFT KEY 1** toggles the DUT outlet Polarity from Normal to DUT Off to Reverse Polarity, or Reverse to DUT Off to Normal Polarity.
  - ⇒ **SOFT KEY 2** toggles the DUT outlet from Earth to No Earth.
  - ⇒ **SOFT KEY 3** toggles the DUT outlet from L2 to No L2.
- Modify the configuration of the front panel outlet by pressing the appropriate **SOFT KEY** on the 601PRO.
- Press the **print data** key at any time to generate a printout of the latest measurement.

### Accessible Leakage

Accessible Leakage measurements are taken from the RED input lead referenced to the DUT Earth. Accessible Leakage cannot be selected from the **Manual** menu unless the IEC 1010 test standard is selected.

The following outlet conditions apply when performing this test:

- ⇒ Normal Polarity, Earth Open, Outlet ON
- ⇒ Normal Polarity, Outlet ON
- ⇒ Normal Polarity, L2 Open, Outlet ON
- ⇒ Reversed Polarity, Outlet ON
- ⇒ Reversed Polarity, Earth Open, Outlet ON
- ⇒ Reversed Polarity, L2 Open, Outlet ON

To measure accessible leakage using the **test-shortcut** keys:

- From the **MAIN MENU**, or with the outlet unpowered, plug the DUT into the 601PRO front panel outlet, and turn on the device.
- Press **shortcut key 9**. The **Accessible Voltage** test appears on the display.

- Press **LEAKAGE (SOFT KEY 4)**. The **Accessible Leakage** test appears on the display, and the test begins immediately. Display values are continuously updated until another test is selected.

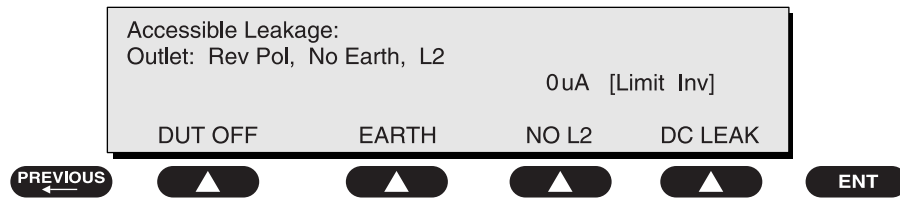

baw062f.eps

- Press **SOFT KEYS 1-4** to select the desired configuration:
  - ⇒ **SOFT KEY 1** toggles the DUT outlet Polarity from Normal to DUT Off to Reverse Polarity, or Reverse to DUT Off to Normal Polarity.
  - ⇒ **SOFT KEY 2** toggles the DUT outlet from Earth to No Earth.
  - ⇒ **SOFT KEY 3** toggles the DUT outlet from L2 to No L2.
  - ⇒ **SOFT KEY 4** toggles between RMS Leakage and DC Leakage.
- Modify the configuration of the front panel outlet by pressing the appropriate **SOFT KEY** on the 601PRO:
- Select the desired Leakage reading type (RMS or DC) using **SOFT KEY 4**.
- Press the **print data** key at any time to generate a printout of the latest measurement.

### Shortcut Key **/**: VDE Equivalent Device Leakage Test

The Equivalent Device Leakage test measures the current flowing from the shorted L1 and L2 Mains terminals of the DUT to the DUT PE in response to an applied isolated AC voltage greater than 110% of the Mains voltage. The Equivalent Device Leakage test cannot be selected from the **Manual** menu unless the VDE 751-1 or VDE 701 test standard is selected.

- **Note:** *This test should be performed with a mains voltage > 180 VAC as specified by the VDE 701 and VDE 751 test standards.*

It is recommended that a leakage calibration be performed whenever the mains voltage level is changed (120 VAC to 220 VAC, or 220 VAC to 120 VAC), or when using the unit for the first time. This can be done from either of the VDE Equivalent leakage tests or from Mains on Applied Part.



- **Important:** *The Equivalent Device Leakage test uses the IEC 601-1 Test Load exclusively. This is true no matter what the currently defined test standard is.*

The limit value and the class/type designations will vary depending on the currently selected test standard.

The following test conditions apply:

- ⇒ Mains supply to DUT L1 and L2 Open
- ⇒ DUT L1 and L2 shorted together
- ⇒ 110% of mains voltage is applied between L1, L2 and Earth at the DUT outlet.

To perform an Equivalent Device Leakage test:

- From the **MAIN MENU**, or with the outlet unpowered, plug the DUT into the 601PRO front panel outlet, and turn on the device.
- Press the **/ shortcut key**. The **Equivalent Device Leakage** test is displayed:

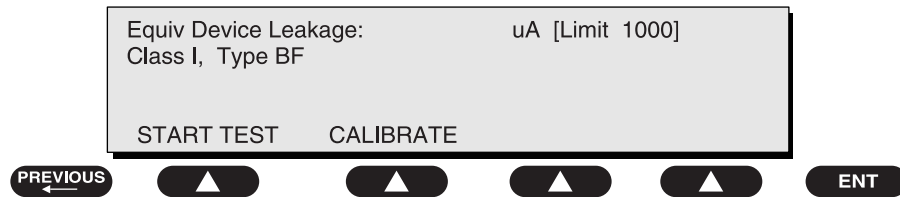

- Press **START TEST (SOFT KEY 1)** to begin the test.

baw063f.eps



**WARNING:** *High voltage is present at the DUT terminals while measurements are being taken.*

- Press the **print data** key to generate a printout of the latest measurement.

To perform a calibration from the **Equivalent Device Leakage** test, press **CALIBRATE (SOFT KEY 2)**.

- Disconnect ALL patient leads, test leads, and DUT outlet connections.
- Press **CAL** to begin calibration, as shown.

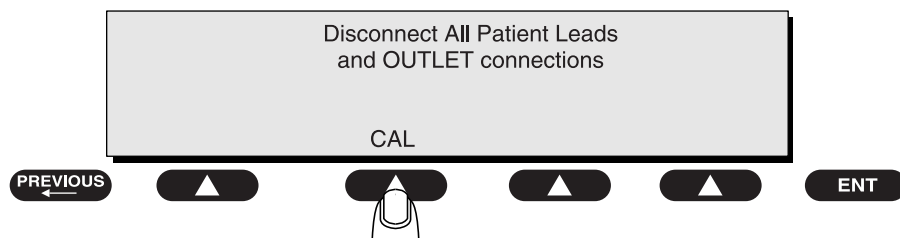

baw059f.eps



**WARNING:** *A 2-beep-per-second signal indicates high voltage present at the applied part terminals while a calibration is being performed.*

- When the calibration is finished, the **Equivalent Device Leakage** test will reappear.

 **Note:** If the calibration fails the previously stored readings will be used until a passing calibration has occurred. Also, the **esc/stop** key has no effect during calibration.

### **Shortcut Key - : VDE Equivalent Patient Leakage Test**

The Equivalent Patient Leakage Test measures the current flowing from ALL of the Applied Parts terminals to the shorted L1, L2 and DUT PE in response to an applied isolated AC voltage greater than 110% of the Mains voltage. Equivalent Device Leakage test cannot be selected from the manual menu unless the VDE 751-1 or VDE 701 test standard is selected.

 **Note:** *This test should be performed with a mains voltage > 180 VAC as specified by the VDE 701 and VDE 751 test standards.*

It is recommended that whenever the mains voltage level is changed (120 VAC to 220 VAC, or 220 VAC to 120 VAC), or when using the unit for the first time, that a leakage calibration be performed. This can be done from either of the VDE Equivalent leakage tests or from Mains on Applied Part.

**This test is always performed with all 5 leads.**



**Important:** *The Equivalent Patient Leakage test uses the IEC 601-1 Test Load exclusively. This is true no matter what the currently defined test standard is.*

The following conditions apply:

- ⇒ Mains supply to DUT L1 and L2 Open
- ⇒ DUT L1 and L2 shorted to DUT PE
- ⇒ 110% of mains voltage is applied between individually selected ECG jacks connected to applied parts and the 601PRO Earth.

To perform a VDE Equivalent Patient Leakage test:

- From the **MAIN MENU**, or with the outlet unpowered, plug the DUT into the 601PRO front panel outlet, and turn on the device.
- Attach Patient Leads to 601PRO ECG jacks.
- From the **MAIN MENU**, or with the outlet unpowered, plug the DUT into the 601PRO front panel outlet, and turn on the device.
- Press the **▣ shortcut key**. The **Equivalent Patient Leakage** test is displayed:

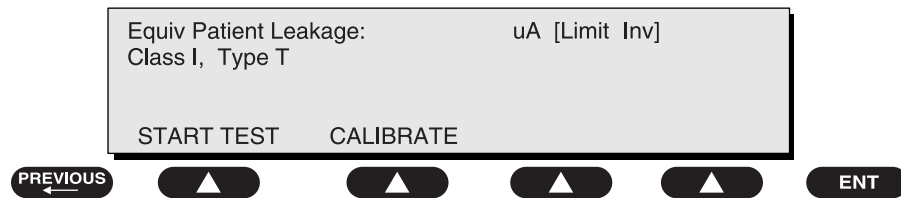

- Press **START TEST (SOFT KEY 1)** to begin the test.

baw064f.eps



**WARNING:** *High voltage is present at the Applied Parts terminals while measurements are being taken.*

- Press the **print data** key to generate a printout of the latest measurement.

To perform a calibration from the **Equivalent Patient Leakage** test, **press CALIBRATION (SOFT KEY 2)**.

- Follow the same process described in **Equivalent Device Leakage**.

## Dual Lead Leakage

**Dual Lead Leakage** currents are measured between the RED and BLACK test leads. Measurements may have either a true RMS or a DC-only response. The **Dual Lead Leakage** test can **ONLY** be accessed from the **Manual** menu.

To perform a **Dual Lead Leakage** test:

- From the **MAIN MENU**, or with the outlet unpowered, plug the DUT into the 601PRO front panel outlet, and turn on the device.
- Attach the RED test lead from the 601PRO to the device. A bare exposed metal area or an applied part should be selected.
- Attach the BLACK test lead from the 601PRO to the device. A bare exposed metal area should be selected.
- From the **MAIN MENU**, press **TESTS/AUTOMODES**, then **MANUAL**, then **\*MORE** until **DUAL LEAD LEAKAGE** is displayed. Press **Dual Lead Leakage**, and the test begins immediately. Display values are continuously updated until another test is selected.

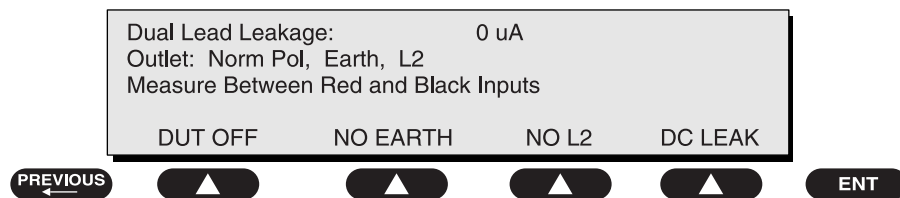

- Press **SOFT KEYS 1-4** to select the desired configuration:
  - ⇒ **SOFT KEY 1** toggles the DUT outlet Polarity from Normal to DUT Off to Reverse Polarity, or Reverse to DUT Off to Normal Polarity.
  - ⇒ **SOFT KEY 2** toggles the DUT outlet from Earth to No Earth.
  - ⇒ **SOFT KEY 3** toggles the DUT outlet from L2 to No L2.
  - ⇒ **SOFT KEY 4** toggles between RMS Leakage and DC Leakage.
- Press the **print data** key at any time to generate a printout of the latest measurement.

baw065f.eps

### ECG Output

The 601PRO generates a series of ECG, performance, and arrhythmia waveforms to verify the accuracy of ECG machines/monitors. ECG Output can ONLY be accessed from the **Manual** menu.

The following outlet condition applies:

⇒ Normal Polarity, Earth Open, Outlet ON

To generate waveforms:

- From the **MAIN MENU**, or with the outlet unpowered, plug the DUT into the 601PRO front panel outlet, and turn on the device.
- Attach the device's ECG leads to the matching 601PRO applied part terminals.
- From the **MAIN MENU**, press **TESTS/AUTOMODES**, then **MANUAL**, then **ECG OUTPUT**.
- At the **ECG/Performance Waveforms** menu, press the **SOFT KEY** below the type of waveform/frequency to output. The outlet is powered on.

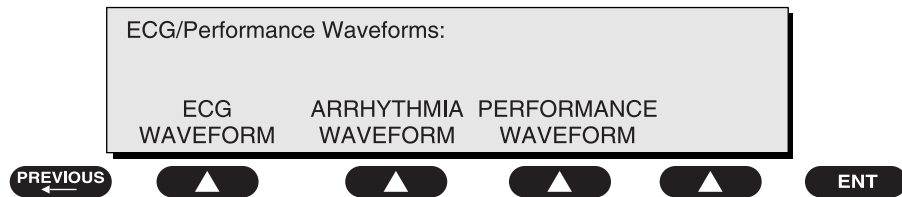

- For example, press **SOFT KEYS 1 - 3** to choose from the waveforms.

baw066f.eps

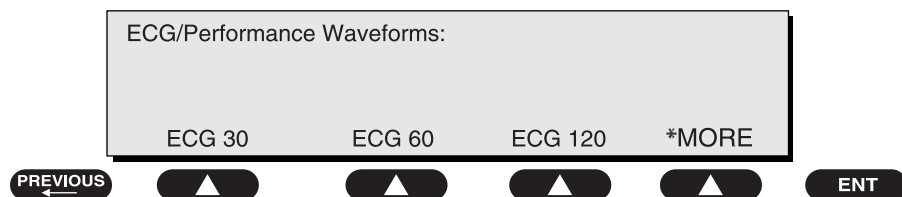

- Press **SOFT KEY 4 (\*MORE)** for additional waveforms.

baw067f.eps

Sample waveforms are shown on the following pages.

### Sample Waveforms

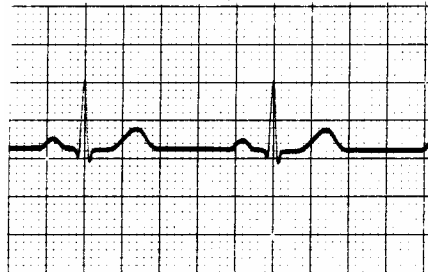

*Normal sinus (ECG 30, ECG 60, ECG 120, ECG 180, ECG 240)*

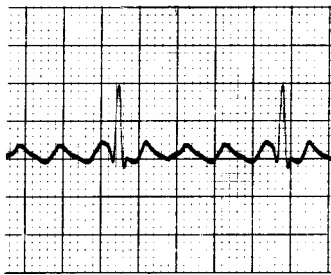

*Atrial Flutter (AFLUT)*

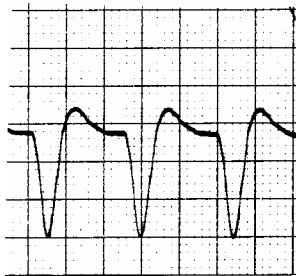

*Ventricular Tachycardia (VTACH)*



*Ventricular Fibrillation (VFIB)*

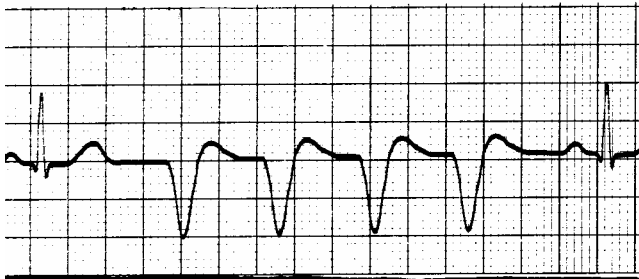

*Run (RUN)*

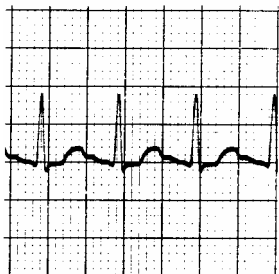

*Atrial Tachycardia (ATACH)*

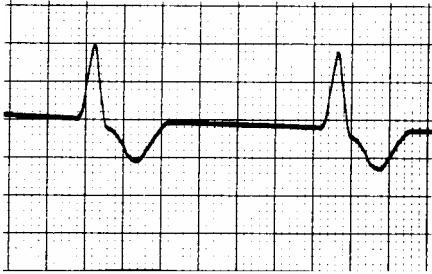

*Idioventricular (IDIO)*

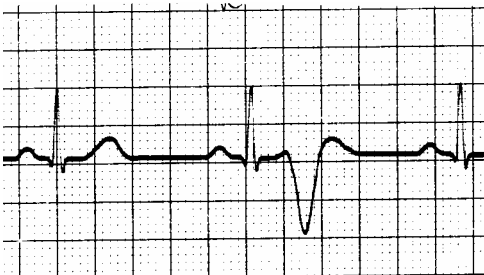

*R on T (R ON T)*

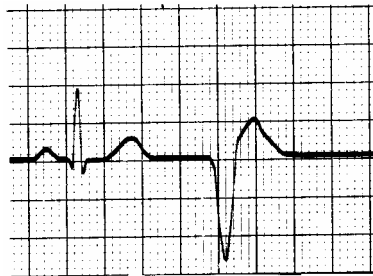

*PVC 1 (PVC1)*

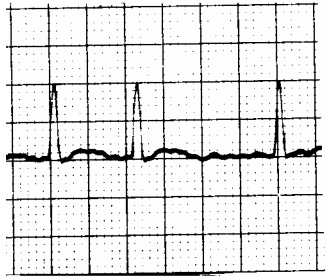

*Atrial Fibrillation (AFIB)*

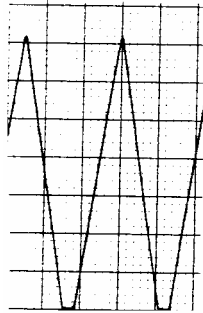

*Triangle 2 Hz*  
(TRI 2HZ)

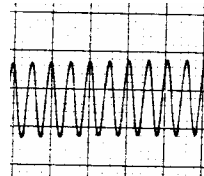

*Sine 10, 40, 50, 60, 100 Hz*  
(SINE 10HZ, SINE 40HZ, SINE 50HZ)  
(SINE 60 HZ, SINE 100HZ)

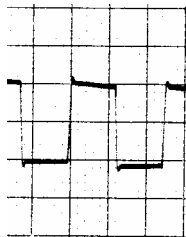

*Square 0.125 Hz, 2 Hz*  
(SQ .125HZ, SQ 2HZ)

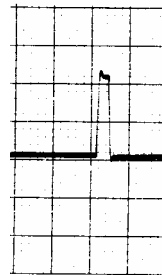

*Pulse 30, 60 BPM*  
(PULSE 30BPM, PULSE 60BPM)

# Auto/Step Modes

Chapter

4

This chapter provides an overview of 601PRO **Auto** and **Step** mode sequences. The **Auto** or **Step** sequence performs all electrical safety tests required based on the Standard, Class, and Type designated at the start of the test. *Chapter 8, Standards and Principles*, provides a complete list and the order of execution of tests, which are detailed in *Section 3: Refer to Test Limits for the Selected Standard*. The operator may either recall a Device Record based on its control number if Device Records were selected at setup, or a Template based on its name if Templates were selected at setup, or use the instrument's present settings to execute a sequence.

- **Note:** The 601PRO allows the operator to make multiple measurements for the enclosure leakage test while executing an **Auto** sequence. This allows the operator to probe the DUT and find the highest reading before continuing. *Chapter 2, Setting Up the 601PRO*, provides information for enabling this feature in *Section 7: Configure Enclosure Leakage for Auto Mode Sequence*.

- 1. **Selecting Auto or Step Mode Testing**
- 2. **Executing Auto and Step Mode Tests**
- 3. **Creating/Editing a Device Record or Template**

## 1. Selecting Auto or Step Mode Testing

- From the 601PRO **MAIN MENU**, press **TESTS/AUTOMODES**:

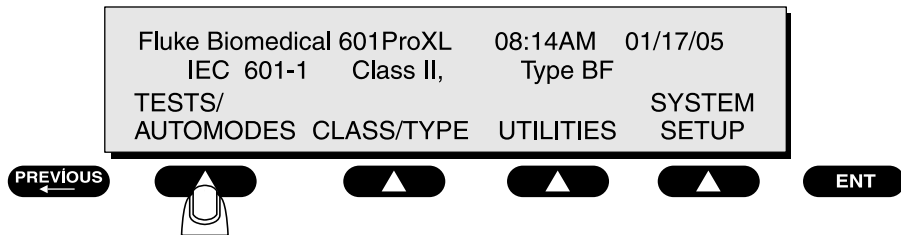

- Select either **AUTO** mode or **STEP** mode:

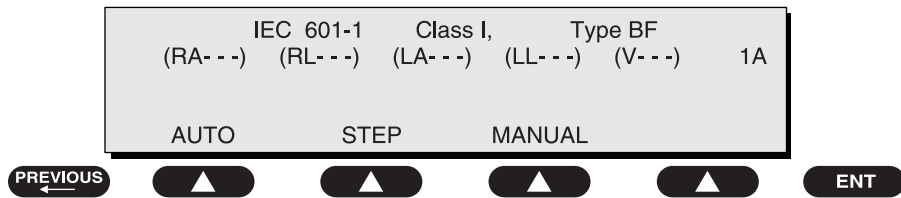

- **Note:** The following instructions and displays are based on having **device records** selected during setup. If **templates** was selected during setup, then replace **control number** with **template name** in the following displays examples.

When prompted for a control number or template name, the operator will have several options:

1. Enter a control number or template name, which will recall a file from memory. The Test Standard, Class, Type and other test information will be set from this file. The test result will be printed and stored in memory for printing or exporting at a later time.

or,

2. Press the **ENT** key without entering a control number or template name, which will use the present settings. The test result will be printed only and will not be stored. The present settings include the current Test Standard, Class, Type, and Lead definitions plus the following defaults:

- Power Off Delay of 5 seconds
- Startup Delay of 5 seconds
- Protective Earth Resistance Applied Current of 1 Amp

or,

3. Using the **SCROLLING**<sup>1</sup> feature in one of the following ways:
  - Press the **SCROLL** soft key to scroll through the list of existing device records or templates. When the preferred test is found, press **ENT** soft key to start the test.
  - Use the A..Z soft key to type in the first character of the control number or template name and press **SCROLL** to find it. Press **ENT** soft key to start the test.
  - If there are several control numbers or template names with the same first character(s), after using the A..Z soft key to type in the first character of the template name, press the **CURSOR**→ to move to the next character, and so on until you have either the entire name or a good portion of it. If it's the entire number, or name, press **ENT** soft key to start the test. If it's just part of the number or name, press **SCROLL** to scroll through possible options and **ENT** soft key to start the test.
4. Use the optional keyboard plugged into the ISA601PROXL to type in either the first character (or several characters) of the control number or template name and press **SCROLL** to find the template name. Press **ENT** soft key to start the test.

or,

5. Create a new device record.

---

<sup>1</sup> Scrolling is only available in units operating with V2.00 or later firmware.

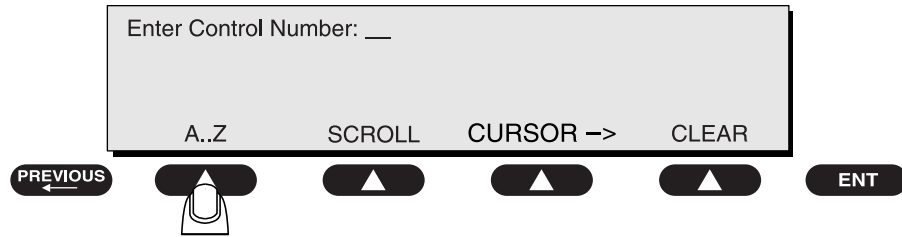

baw069f.eps

To enter a **control number** for a device record or a **template name** currently stored in the 601PRO's database, use a combination of the **SOFT KEYS** for alphanumeric and special characters, and the **test-shortcut** keys for numeric keys. Press **ENT** when the control number has been entered.

The **control number** or **template name**, if entered, is displayed along with the Test Standard and Class/Type designations that will determine the tests to perform and their limits. When the DUT is connected and ready for testing, press **START TEST (SOFT KEY 1)**.

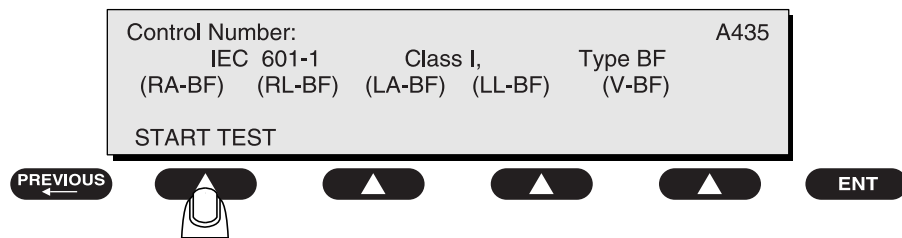

baw070f.eps

If a **control number** or **template name** is not found in memory, create a device record or template as follows:

- From the 601PRO **MAIN MENU**, press **TESTS/AUTOMODES**, then select either **AUTO** mode or **STEP** mode and press **ENT**.
- Enter a **control number** or **template name** and press **ENT** at the following screen:

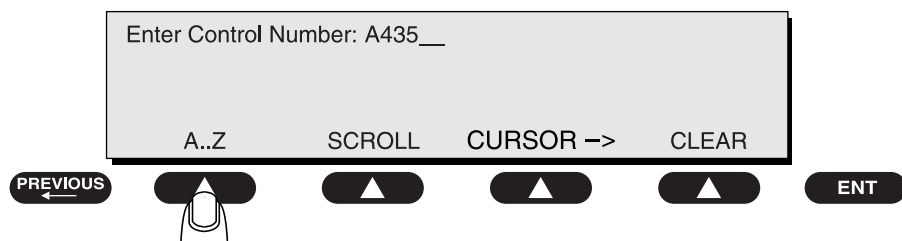

baw071f.eps

- Press **YES** at the following screen:

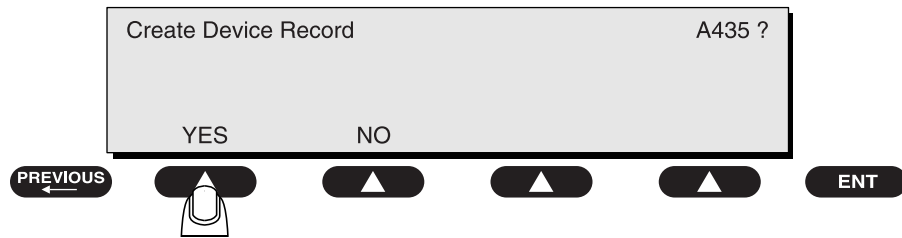

baw072f.eps

The **control number** or **template name** is displayed along with the Test Standard and Class/Type designations that will determine the tests to perform and their limits. When the DUT is connected and ready for testing, press **START TEST (SOFT KEY 1)**.

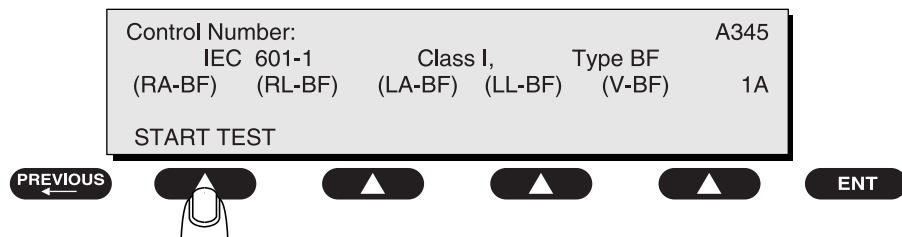

baw073f.eps

## 2. Executing Auto and Step Mode Tests

Based on the Test Standard, Class, Type and Number of Leads selected, the 601PRO will perform the required tests in the controlled power sequence described in *Section 3: Refer to Test Limits for the Selected Standard (Chapter 8)*. If zero leads are defined, no tests requiring leads will be performed. If only one lead is defined, those tests requiring lead to lead measurements will be skipped.

Press the **esc/stop** key to abort the **Auto** or **Step** sequence at any time. Once the **esc/stop** key has been pressed, the unit may complete the test it is presently executing before aborting.

When performing an **Auto** mode test sequence that includes Protective Earth Resistance, the testing will pause after completion of the Protective Earth measurement and allow the operator to adjust any connections. Press **NEXT->** to continue the sequence (see below).

Whenever an **Auto** sequence is executed that includes a Protective Earth Resistance Test, the operator can take as many Protective Earth Resistance readings as desired by pressing the **START TEST** soft key. The last reading taken is the one saved. Only the last reading taken is used for a Pass/Fail determination.

Protective Earth Resistance during an **Auto** sequence:

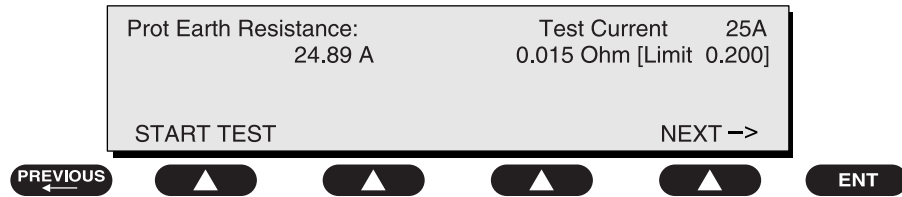

baw074f.eps

During **Step** mode operation, the operator must press the **NEXT->** key to advance to the next test in the sequence. At the time the **NEXT->** key is pressed, the value displayed will be stored as the data for that test. Pressing the **NEXT->** key multiple times at the same screen is discouraged because some tests may be skipped. Examples of **Step** mode test sequence screens are shown below.

Mains Voltage during **Step** mode 1:

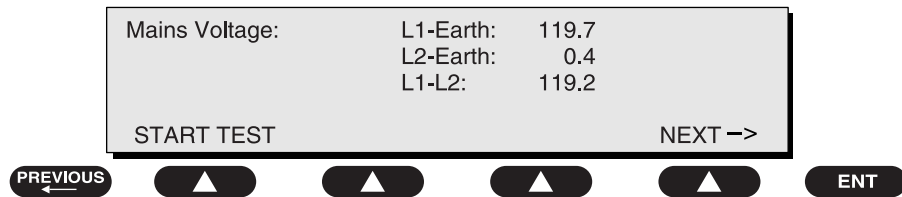

baw075f.eps

Insulation Resistance during **Step** mode 2:

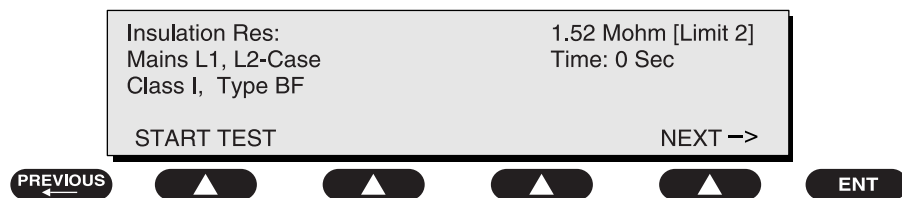

baw076f.eps

Enclosure Leakage during **Step** mode 3:

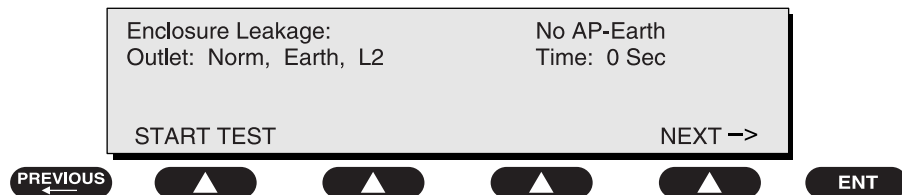

baw077f.eps

When either **Auto** or **Step** mode is completed, the technician's name **must** be entered. The name will be stored in the result record. The technician's name will default to the previous name entered, if one exists.

At the following screen, enter the **Technician Name** and press **ENT**.

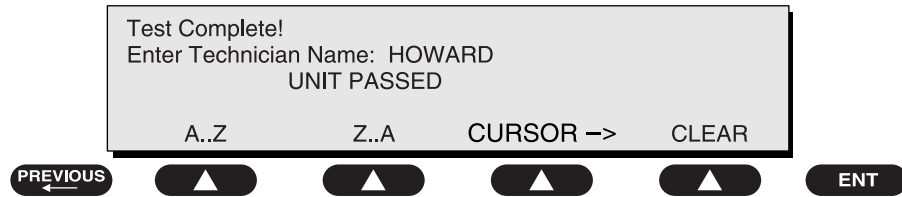

baw078f.eps

- Note:** If **templates** was selected during setup, then prompts for Serial Number, Control Number, and Location will also be displayed at this point.

If desired, enter comments to store in the result record as shown below. Press **ENT** to print test results and return to the **MAIN MENU**.

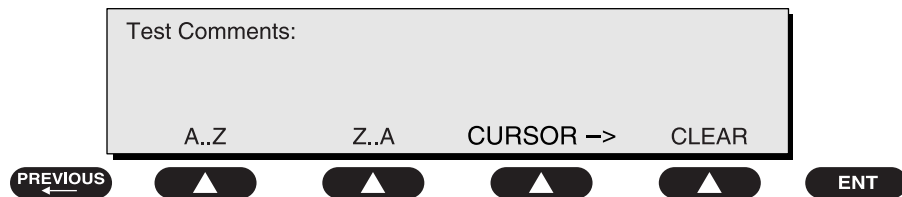

baw079f.eps

- Note:** The maximum number of characters allowed for the **Technician Name** is 15; the maximum for the **Test Comments** is 40.

**Warning:** Caution should be taken, as high voltage (110 percent of mains, or 500 VDC) will appear on all leads - particularly when test clips are in place and only one or two leads are used. Leads should not be left on any terminal that is not specified for the number of leads selected, as incorrect readings can occur.

- Note:** Press the **Esc** key to discontinue an **Auto/Step** sequence at the **Enter Technician Name** and **Test Comments** screens.



When performing an **Auto** sequence with startup or power off delays, press the **NEXT** key once the DUT is ready to proceed with the testing; otherwise, the testing of the DUT will continue once the delay has expired. This is most beneficial for equipment that has a variable startup or power off time and allows the operator to skip the remainder of either delay by pressing the **NEXT** key.

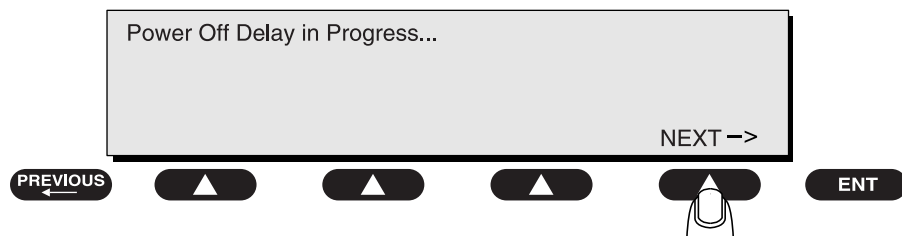

baw080f.eps

### 3. Creating/Editing a Device Record or Template

- Note:** In this section, details about device records are given to explain how to create, edit, delete, and print them, as well as transmit and receive them from a computer. These details also apply to templates with minor differences that are explained in chapter 2, *Configuring for Device Records or Templates*. If **templates** was selected under **System Setup**, then replace Device Records with Templates in the following display examples.

Device records and templates require the following information at a minimum: the **test standard**, the **class/type**, the **protective earth resistance current**, and the **number of applied parts**. In addition, Device Records also require the **control number**, and Templates require a name.

- At the **MAIN MENU**, press **UTILITIES**:

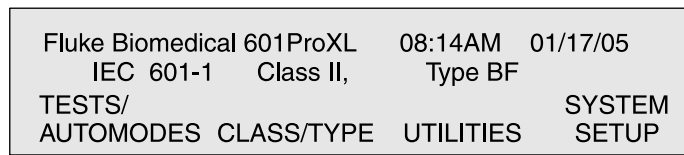

baw004f.eps

- Press **DEVICE RECORDS**.

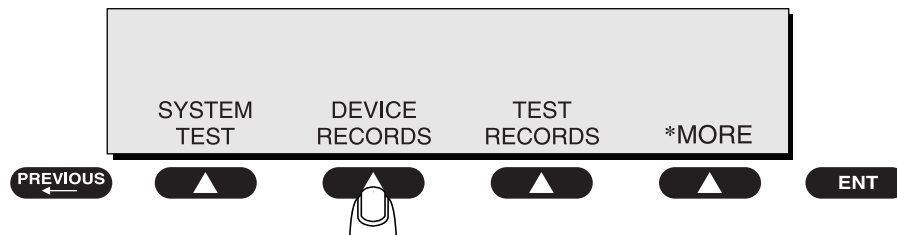

baw081f.eps

- At the **Device Record Utility** menu, press **CREATE RECORD**.

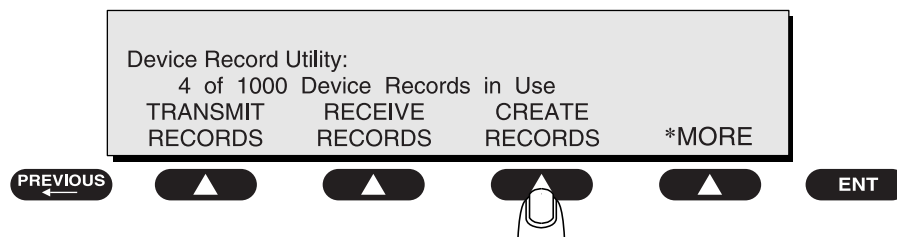

baw082f.eps

- Enter a **control number** using the **SOFT KEYS** and the **test-shortcut** keys, and press **ENT**:

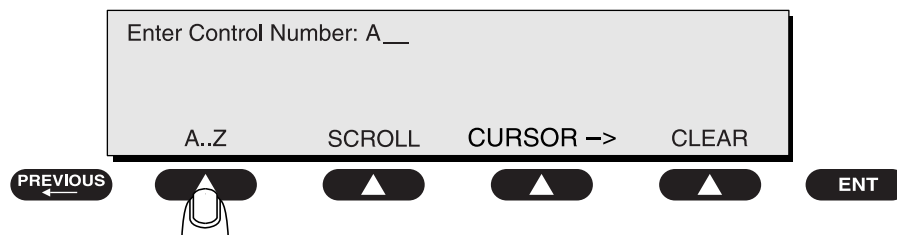

baw083f.eps

- To edit a device record, press **\*MORE** at the **Device Record Utility** menu:

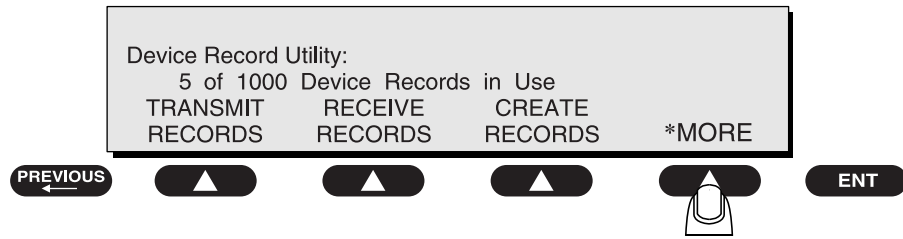

baw084f.eps

- Press **EDIT RECORD** at the following menu:

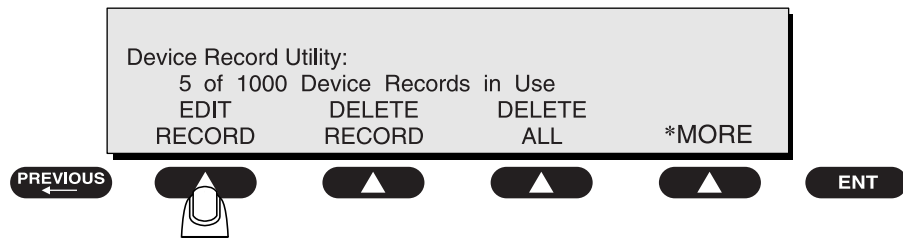

baw085f.eps

- Enter a **control number** using the **SOFT KEYS** and the **test-shortcut** keys, and press **ENT**:

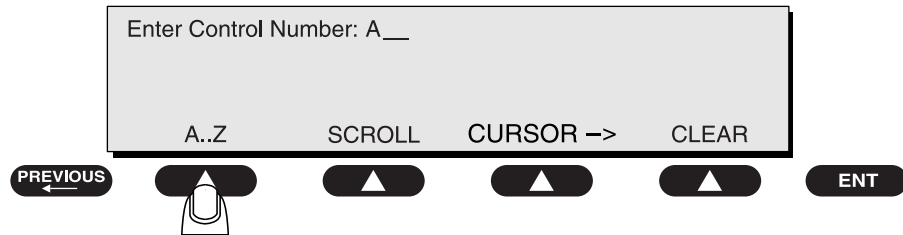

baw083f.eps

- Note:** When editing a device record that has pre-existing results, these results will reflect any subsequent changes made to the original device record.

- Press the **SOFT KEY** below the desired test standard at the **Select Test Standard** menu or press **\*MORE** for additional options.

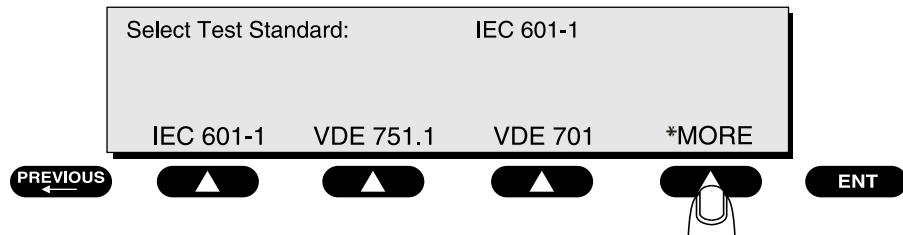

baw086f.eps

Press **ENT**.

- Select the **Class/Type** or press **\*MORE** for additional options.

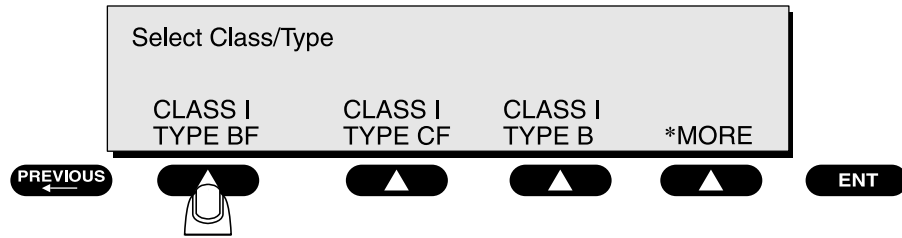

baw087f.eps

Press **ENT**.

- Select the **Applied Current**.

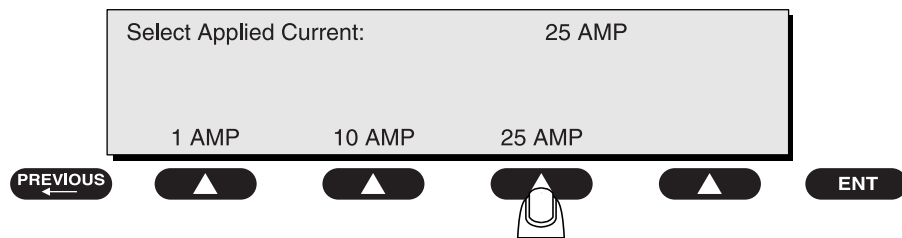

baw088f.eps

The **Applied Current** selection is used to define the current that will be used during the Protective Earth Resistance test. The operator will always be required to make this selection whether or not the selected test standard performs the Protective Earth Resistance test.



**Warning!** Using a 25 Amp applied current may damage some older devices. Test with a 10 Amp current in these cases.

Press **ENT**.

Use the **test-shortcut keys** to enter information on the following screens.

- Enter the **Startup Delay**:

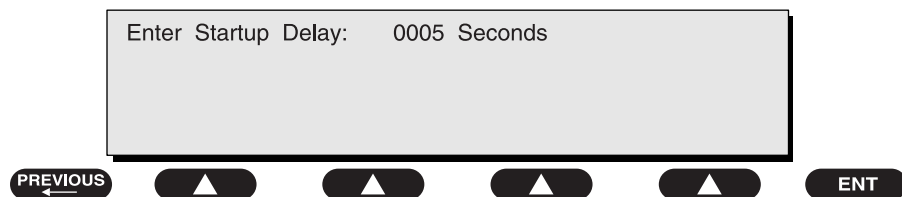

baw089f.eps

A Startup Delay is inserted between various tests in the **Auto** and **Step** sequences. The Startup Delay is performed after the DUT Outlet has been set in the correct state for the next test to be performed. The Startup Delay allows the device being tested to reach a steady state after a change in Outlet Polarity or a change from a power-off state to a power-on state. The Startup Delay is used with equipment that requires time after power-up to reach the condition under which it will be tested.

Press **ENT**.

☛ **Note:** When executing the **Auto** sequence, the operator can press the **NEXT** key once the DUT is ready to proceed with the testing, or the operator can wait until the delay has expired. Thus, by setting a much longer delay time in the device record, the operator can accommodate DUTs with variable startup.

- Enter the **Power Off Delay**:

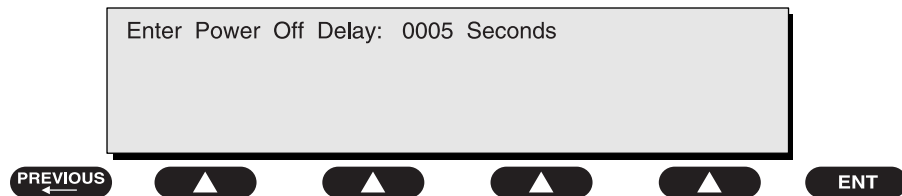

A Power Off Delay is inserted between various tests in the **Step** and **Auto** sequences. The Power Off Delay is performed after power has been removed from the DUT Outlet because the Outlet has been disabled, or L2 has been opened. A Power Off Delay allows equipment time to stop before being presented with a new power condition. baw090f.eps

Press **ENT**.

☛ **Note:** The minimum value of a Power Off Delay is 1 second.

☛ **Note:** When executing the **Auto** sequence, the operator can press the **NEXT** key once the DUT is ready to proceed with the testing, or the operator can wait until the delay has expired. Thus, by setting a much longer delay time in the device record, the operator can accommodate DUTs with variable power off times.

- Enter the **Number of Applied Part Leads**:

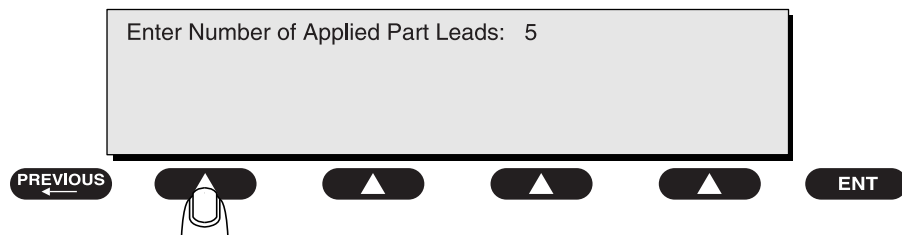

This selection allows the operator to define the number of applied parts to be tested during Mains on Applied Part, Patient Leakage, Insulation Resistance, and Patient Auxiliary Current tests. This screen will only appear when the selected Test Standard is one of the following: baw091f.eps

- ◆ IEC 601-1
- ◆ HEI 95
- ◆ Custom 1-4\*
- ◆ AAMI\*
- ◆ AS/NZS 3551

Press **ENT**.

**\*Note:** When using the AAMI or Custom test standard, only the applied parts can be assigned; the Type cannot be changed.

- Make lead type assignments at the **Define Lead and Select Type** menu:

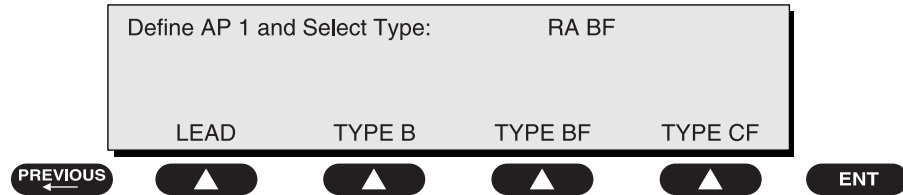

baw092f.eps

This selection allows the operator to define the Types for each of the applied parts during the following tests: Mains on Applied Part, Insulation Resistance – Applied Part, Patient Leakage, and Patient Auxiliary Current. The Limits applied to the leads will be set based on the Type selected.

Use the following procedure to test a defibrillator with two paddles, Type BF, and three ECG leads, RA, LA and LL, all of which are Type CF.

Assuming that the ECG leads will be connected to the 601PRO applied part terminals with the identical names, the paddles would have to be connected to the RL and any V terminal. Define the lead types using the following steps:

1. The first lead that appears for definition is RA. Since RA is Type CF, press **TYPE CF**:

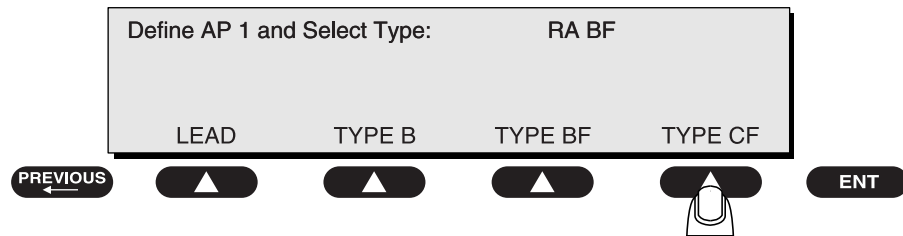

baw093f.eps

Press **enter** to advance to the next lead (RL).

2. Since RL is Type BF, press **TYPE BF**:

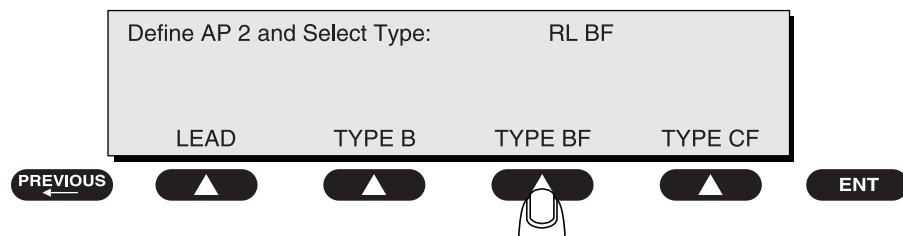

baw094f.eps

Press **ENT** to advance to the next lead (LA).

3. Since LA is Type CF, press **TYPE CF**.

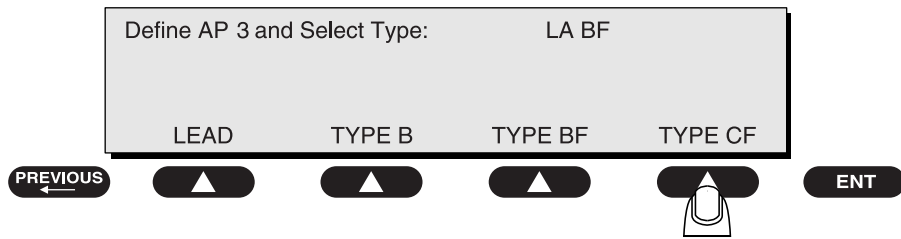

baw095f.eps

Press **ENT** to advance to the next lead (LL).

4. Since LL is Type CF, press **TYPE CF**.

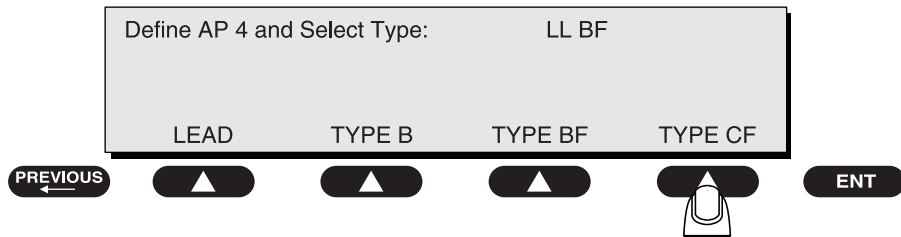

baw096f.eps

Press **ENT** to advance to the next lead (V1-V6).

Since the V lead is Type BF, press **TYPE BF**.

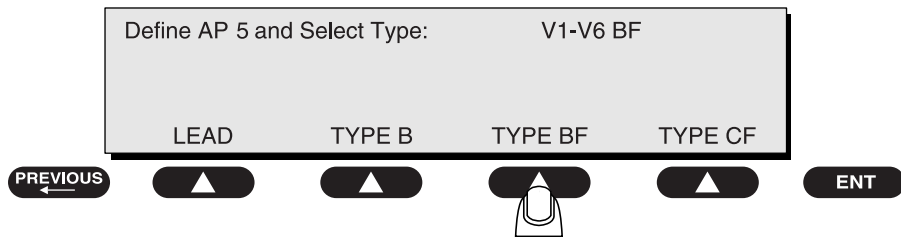

baw097f.eps

**Note:** The applied parts are always assigned left to right, beginning with the top row.

Use the **test-shortcut keys** and the **SOFT KEYS** to enter information on the following screens.

- Enter the **Serial Number** (Not required for templates):

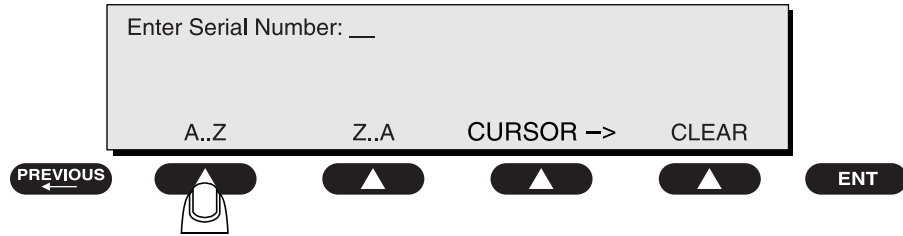

Press **ENT**.

baw098f.eps

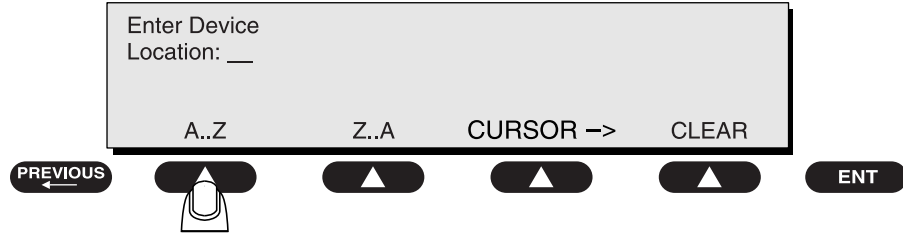

Press **ENT**.

baw099f.eps

- Enter the **Device Location** (Not required for templates):

- Enter the **Device Type**:

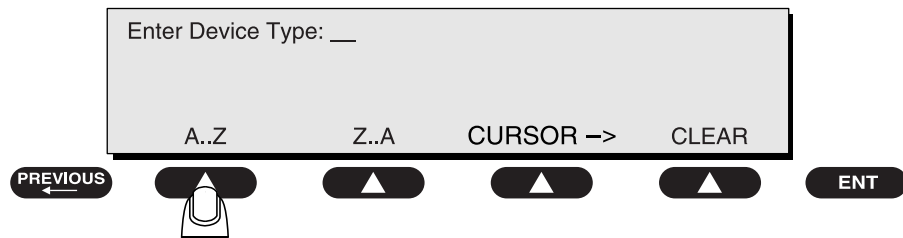

Press **ENT**.

baw100f.eps

- Enter the **Device Manufacturer**:

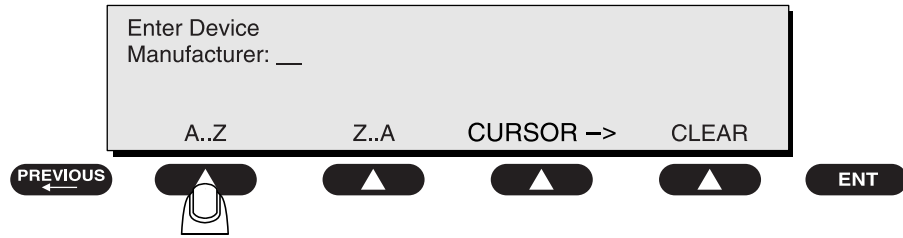

baw101f.eps

Press **ENT**.

- Enter the **Procedure ID**:

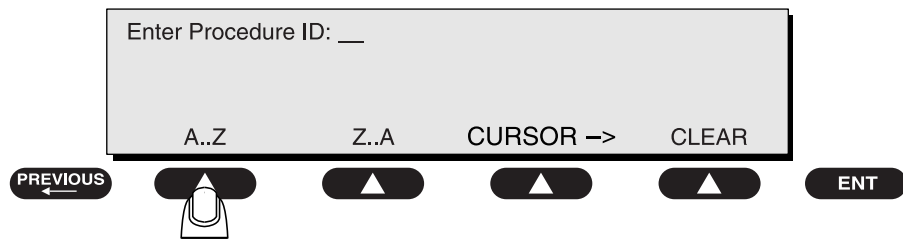

baw102f.eps

Press **ENT**.

- ☛ **Note:** Once the selection is made, the 601PRO will return to the **Device Record Utility** menu, showing that a new record has been added:

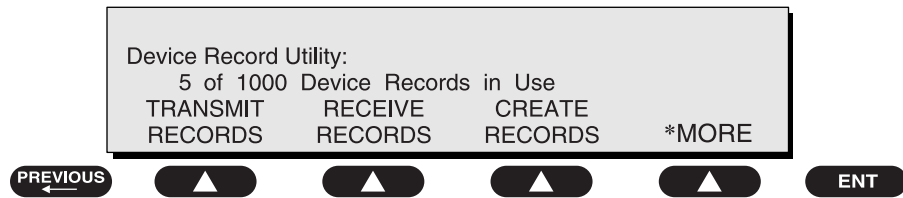

baw103f.eps

- Press **previous** to return to the **MAIN MENU**.

- ☛ **Note:** Each field allows a maximum of 40 characters.

# Test Records

Chapter

5

Using the **Test Record Utility**, the operator can choose to transmit, print, or delete all or any one of the result records on board the 601PRO.

1. **Sending Test Results from the 601PRO to the Host Computer**
2. **Test Data Record: Serial Output**
3. **Printing Test Records**
4. **Deleting Test Records**

## 1. Sending Test Results from the 601PRO to the Host Computer

The serial port parameters of the 601PRO and those of the computer's communication program must match.

- From the 601PRO **MAIN MENU**, press **SYSTEM SETUP** to access the **Select Setup Function** menu. Press **RS232** to modify the 601PRO's baud rate.
- Connect the serial cable and turn the 601PRO power ON.
- From the **MAIN MENU**, press **UTILITIES**.
- Press **TEST RECORDS**.

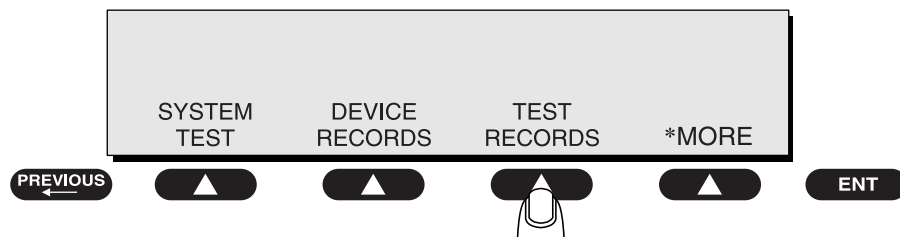

baw134f.eps

At the **Test Record Utility** menu, press **TRANSMIT RECORD**:

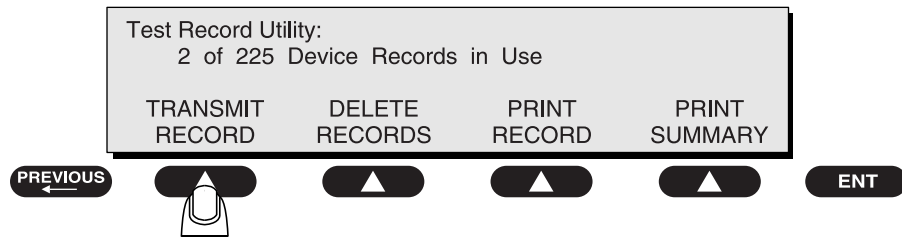

baw104f.eps

Press a **SOFT KEY** to enter a **Result Number** and/or press **ALL RESULTS** to transmit test records.

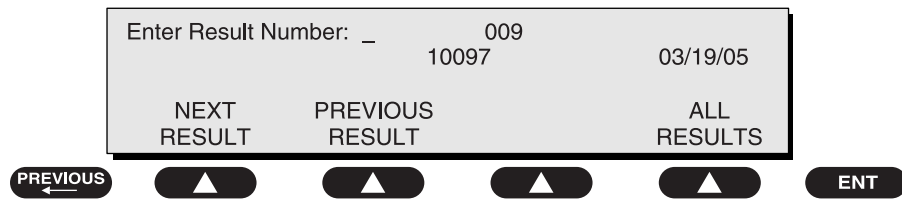

baw105f.eps

Press **START** at the **Transmit Test Record(s)** screen:

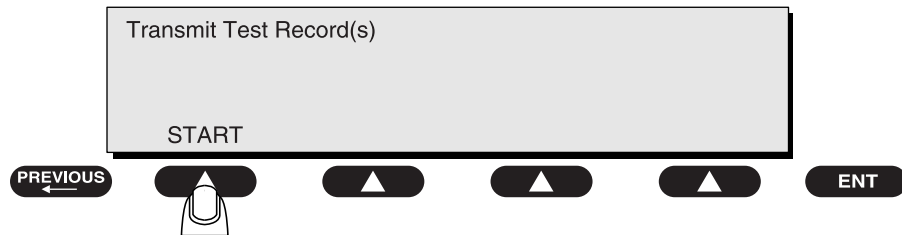

baw106f.eps

Transfer of the information should begin immediately. The following screen is displayed:

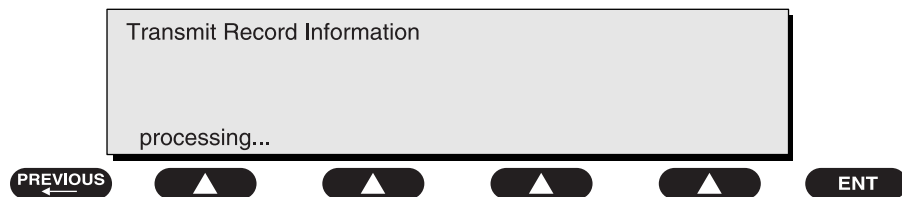

baw107f.eps

When finished, the 601PRO will return to the **Test Record Utility** menu. If there is a problem, an error message will be displayed.

## 2. Test Data Record: Serial Output

Refer to *Appendix D* for a description of ASCII character formatting.

## 3. Printing Test Records

The *601PRO* is equipped with a parallel printer port that allows the instrument to be connected to a compatible external printer for full-format printing of test results. In addition, an optional internal printer allows for simple documentation of test results.

Refer to the *Accessories* list in *Chapter 1* for information on ordering a D25M-C36M parallel printer cable for use with an external printer or additional rolls of paper for the optional internal printer.

Printing can be performed during testing in the **Auto**, **Step**, or **Manual** modes. If an external printer is attached, and control numbers are assigned to test records, a Summary Report of all data gathered during **Auto** or **Step** mode testing could be saved and printed.

In **Manual** mode tests, pressing the **print data** key sends a description of the present test and its associated measurement to the specified printer. During **Auto** or **Step** mode, test results can be automatically printed at the conclusion of the test.

In **Manual** mode tests or while in the **Main Menu**, pressing the **print header** key provides a header that the operator may use to enter the date, time, and device information.

Refer to *Appendix C* for information on printer maintenance.

## 4. Deleting Test Records

- From the **MAIN MENU**, press **UTILITIES**.
- Press **TEST RECORDS**.

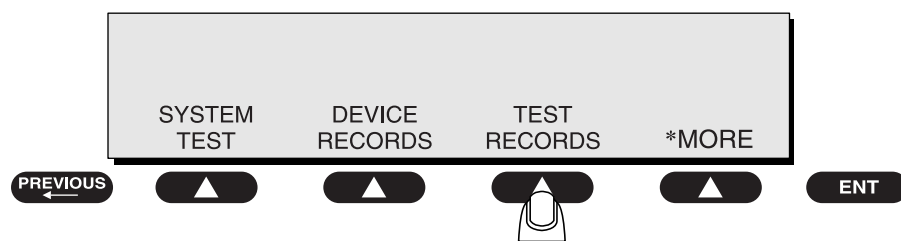

baw108f.eps

At the **Test Record Utility** menu, press **DELETE RECORDS**:

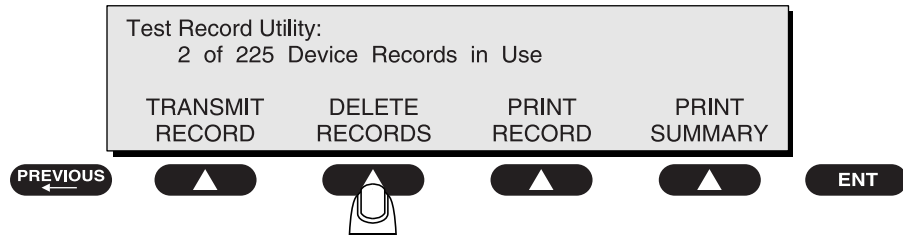

baw109f.eps

Press **YES** or **NO** at the **Delete All Test Results?** screen:

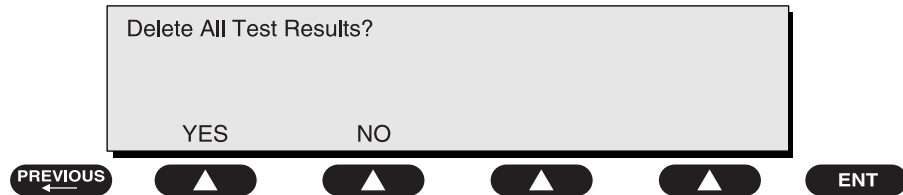

baw110f.eps

When finished, the 601PRO will return to the **Test Record Utility** menu. If there is a problem, an error message will be displayed.

---

### Printing a Header

Printing a header before starting a test allows the technician to log important information about the device to be tested. To print a header in **Manual Mode**, press **print header**. A header is automatically created in **Auto** and **Step Modes**. The **header** contains the following information:

FLUKE BIOMEDICAL	
05/11/00	10:18
CONTROL#:	_____
PROCEDURE ID:	_____
LOCATION:	_____
DEVICE TYPE:	_____
MANUFACTURER:	_____
SERIAL #:	_____
TECHNICIAN:	_____
601PRO#:	121569
CLASS: II	TYPE: BF
AP LEADS: 5	
(RA-BF) (RL-BF) (LA-BF)	
(LL-BF) (V-BF)	

An example of an **Auto** or **Step** mode printout sent to the internal printer is displayed on the following page. A header is automatically placed before test results. An example of a full-page external report is provided on page 5-7.

FLUKE BIOMEDICAL		
05/15/00	23:48	
CONTROL#:		
PROCEDURE ID:		
LOCATION:		
DEVICE TYPE:		
MANUFACTURER:		
SERIAL#:		
TECHNICIAN:BIOMED MAN I		
601PRO#: 145536		
IEC 601-1		
CLASS: I TYPE: BF		
AP LEADS:3		
(RA-B) (RL-BF) (LA-CF)		
MAINS VOLTAGE		
LI-Earth:	118.5 V	
L2-Earth:	0.2 V	
LI-L2:	118.6 V	
PROT. EARTH RESISTANCE		
TEST CURRENT:25A [OHM]	0.001	[0.200]
INSUL RESISTANCE [MOHM]		
LI, L2-CASE Over	[	2]
AP-INSUL RESIST [MOHM]		
RL-Case Over	[	2]
LA-Case Over	[	2]
CURRENT CONSUMPTION		0.0 A
EARTH LEAKAGE CUR. [uA]		
NORM POL	0 [	500]
NO L2	1 [	1000]
REV POL	1 [	500]
NO L2	1 [	1000]
ENCL. LEAKAGE CUR. [uA]		
NORM POL	0 [	100]
NO L2	0 [	500]
NO EARTH	0 [	500]
REV POL	0 [	100]
NO L2	0 [	500]
NO EARTH	1 [	500]
PATIENT LEAKAGE CUR [uA]		
RA-Earth B		
NORM POL	1 [	100]
NO L2	1 [	500]
NO EARTH	1 [	500]
REV POL	1 [	100]
NO L2	1 [	500]
NO EARTH	1 [	500]
PATIENT LEAKAGE CUR [uA]		
RL-Earth BF		
NORM POL	1094 [	100]F
NO L2	1094 [	500]F
NO EARTH	1094 [	500]F
REV POL	1094 [	100]F
NO L2	1094 [	500]F
NO EARTH	1094 [	500]F

PATIENT LEAKAGE CUR (uA)		
LA-Earth CF		
NORM POL	941 [	10]F
NO L2	941 [	50]F
NO EARTH	941 [	50]F
REV POL	941 [	10]F
NO L2	941 [	50]F
NO EARTH	941 [	50]F
MAINS ON APP. PART (uA)		
ISOLATION POL RL		
NORMAL	198 [	5000]
REVERSE	2328 [	5000]
Norm Pol, Earth, L2		
ISOLATION POL LA		
NORMAL	171 [	50]F
REVERSE	2012 [	50]F
Norm Pol, Earth, L2		
ISOLATION POL RL		
NORMAL	199 [	5000]
REVERSE	2331 [	5000]
Rev Pol, Earth, L2		
ISOLATION POL LA		
NORMAL	172 [	50]F
REVERSE	2013 [	50]F
Rev Pol, Earth, L2		
PATIENT AUX CURRENT (uA)		
NORM POL, EARTH, L2		
RA-AII	0 [	100]
RL-AII	0 [	100]
LA-AII	0 [	10]
PATIENT AUX CURRENT (uA)		
NORM POL, EARTH, NO L2		
RA-AII	0 [	500]
RL-AII	0 [	500]
LA-AII	0 [	50]
PATIENT AUX CURRENT (uA)		
NORM POL, NO EARTH, L2		
RA-AII	0 [	500]
RL-AII	0 [	500]
LA-AII	0 [	50]
PATIENT AUX CURRENT (uA)		
REV POL, EARTH, L2		
RA-AII	0 [	100]
RL-AII	0 [	100]
LA-AII	0 [	10]
PATIENT AUX CURRENT (uA)		
REV POL, EARTH, NO L2		
RA-AII	0 [	500]
RL-AII	0 [	500]
LA-AII	0 [	50]
PATIENT AUX CURRENT [uA]		
REV POL, NO EARTH, L2		
RA-AII	0 [	500]
RL-AII	0 [	500]
LA-AII	0 [	50]
Comments:		
UNIT FAILED		

CONTROL#:   
 DEVICE TYPE:   
 MANUFACTURER:   
 SERIAL #:   
 LOCATION:

PROCEDURE ID:   
 601PRO#:   
 TECHNICIAN:

IEC 601-1 CLASS: I Type: BF (RA-B ) (RL-BF) (LA-BF) (LL-CF) (V-CF)

PROT. EARTH RESISTANCE   
 TEST CURRENT:25A [OHM]   
 0.230 [0.200]F   
 CURRENT CONSUMPTION   
 0.1 A

MAINS VOLTAGE   
 L1-Earth : 118.5 V   
 L2-Earth : 0.2 V   
 L1-L2 : 118.9 V

ENCL. LEAKAGE CUR. [uA]			EARTH LEAKAGE CUR. [uA]	
NORM POL	1 [ 100]	1 [ 100 DC]	NORM POL	1 [ 100]
NO L2	1 [ 500]	1 [ 500 DC]	NO L2	1 [ 500]
NO EARTH	1 [ 500]	1 [ 500 DC]		
REV POL	1 [ 100]	1 [ 100 DC]	REV POL	1 [ 100]
NO L2	1 [ 500]	1 [ 500 DC]	NO L2	1 [ 500]
NO EARTH	1 [ 500]	1 [ 500 DC]		

INSUL RESISTANCE [MOHM]   
 L1, L2-Case OVER [ 2]

AP-INSUL RESIST [MOHM]	RA-Case	RL-Case	LA-Case	LL-Case	V1-V6-Case
	0 [ 2]	0 [ 2]	0 [ 2]	0 [ 2]	0 [ 2]

PATIENT LEAKAGE CUR. [uA]	RA-Earth	RL-Earth	LA-Earth	LL-Earth	(V1-V6)-Earth
NORM POL	0 [ 100]	0 [ 100]	0 [ 100]	0 [ 10]	0 [ 10]
NO L2	0 [ 500]	0 [ 500]	0 [ 500]	0 [ 50]	0 [ 50]
NO EARTH	0 [ 500]	0 [ 500]	0 [ 500]	0 [ 50]	0 [ 50]
REV POL	0 [ 100]	0 [ 100]	0 [ 100]	0 [ 10]	0 [ 10]
NO L2	0 [ 500]	0 [ 500]	0 [ 500]	0 [ 50]	0 [ 50]
NO EARTH	0 [ 500]	0 [ 500]	0 [ 500]	0 [ 50]	0 [ 50]

PATIENT LEAKAGE CUR. [uA] DC	RA-Earth	RL-Earth	LA-Earth	LL-Earth	V1-V6-Earth
NORM POL	0 [ 100DC]	0 [ 100DC]	0 [ 100DC]	0 [ 10DC]	0 [ 10DC]
NO L2	0 [ 500DC]	0 [ 500DC]	0 [ 500DC]	0 [ 50DC]	0 [ 50DC]
NO EARTH	0 [ 500DC]	0 [ 500DC]	0 [ 500DC]	0 [ 50DC]	0 [ 50DC]
REV POL	0 [ 100DC]	0 [ 100DC]	0 [ 100DC]	0 [ 10DC]	0 [ 10DC]
NO L2	0 [ 500DC]	0 [ 500DC]	0 [ 500DC]	0 [ 50DC]	0 [ 50DC]
NO EARTH	0 [ 500DC]	0 [ 500DC]	0 [ 500DC]	0 [ 50DC]	0 [ 50DC]

PATIENT AUX CURRENT [uA]	RA-All	RL-All	LA-All	LL-All	V1-V6-All
NORM POL	0 [ 100]	0 [ 100]	0 [ 100]	0 [ 10]	0 [ 10]
NO L2	0 [ 500]	0 [ 500]	0 [ 500]	0 [ 50]	0 [ 50]
NO EARTH	0 [ 500]	0 [ 500]	0 [ 500]	0 [ 50]	0 [ 50]
REV POL	0 [ 100]	0 [ 100]	0 [ 100]	0 [ 10]	0 [ 10]
NO L2	0 [ 500]	0 [ 500]	0 [ 500]	0 [ 50]	0 [ 50]
NO EARTH	0 [ 500]	0 [ 500]	0 [ 500]	0 [ 50]	0 [ 50]

PATIENT AUX CURRENT [uA] DC	RA-All	RL-All	LA-All	LL-All	V1-V6-All
NORM POL	0 [ 10DC]	0 [ 10DC]	0 [ 10DC]	0 [ 10DC]	0 [ 10DC]
NO L2	0 [ 50DC]	0 [ 50DC]	0 [ 50DC]	0 [ 50DC]	0 [ 50DC]
NO EARTH	0 [ 50DC]	0 [ 50DC]	0 [ 50DC]	0 [ 50DC]	0 [ 50DC]
REV POL	0 [ 10DC]	0 [ 10DC]	0 [ 10DC]	0 [ 10DC]	0 [ 10DC]
NO L2	0 [ 50DC]	0 [ 50DC]	0 [ 50DC]	0 [ 50DC]	0 [ 50DC]
NO EARTH	0 [ 50DC]	0 [ 50DC]	0 [ 50DC]	0 [ 50DC]	0 [ 50DC]

MAINS ON APP. PART [uA]	RA	RL	LA	LL	(V1-V6)
NORMAL ISOLATION POL					
Norm Pol	0 [ 5000]	0 [ 500]	0 [ 500]	0 [ 50]	0 [ 50]
Rev Pol	0 [ 5000]	0 [ 500]	0 [ 500]	0 [ 50]	0 [ 50]
REVERSED ISOLATION POL					
Norm Pol	0 [ 5000]	0 [ 500]	0 [ 500]	0 [ 50]	0 [ 50]
Rev Pol	0 [ 5000]	0 [ 500]	0 [ 500]	0 [ 50]	0 [ 50]

Comments:

UNIT FAILED



---

# Device Records and Templates

Chapter

6

Using its serial port, the 601PRO can transfer device information to and from a computer, and send stored test results to a computer. The 601PRO has enough memory to save 1000 device records and/or templates, as well as 225 auto-sequence test results.

---

## Setup Requirements

- ❑ Communications software, such as *ProComm*<sup>TM</sup>, *CrossTalk*<sup>TM</sup>, *Kermit*<sup>TM</sup>, *Carbon Copy*<sup>TM</sup> or Fluke Biomedical's *OTIS*<sup>TM</sup> must be loaded on the host computer.
- ❑ The host computer and the 601PRO both must be set to the same communications parameters (for example, 2400 Baud, No Parity, 8 Data Bits, and 1 Stop Bit).
  - Set up communication parameters for the 601PRO by pressing **SYSTEM SETUP** then **RS232** key at the **MAIN MENU**. Select the appropriate Baud Rate. The other communications parameters are fixed at 1 Stop Bit, 8 Data Bits, and No Parity.
  - Set up communication parameters for the host computer following instructions provided with the installed communications software.
- ❑ A 9-pin male to 9-pin female D-type connector (available from Fluke Biomedical or an electronics supply outlet) must be attached to the computer and the 601PRO.

---

## Using the Device Information Record Utility

Use the following checklist to transfer data files from the 601PRO to a connected personal computer.

- |  |
|--|
| <ol style="list-style-type: none"><li><b>1. Connecting the 601PRO and the Host Computer</b></li><li><b>2. Sending Device Information Records from the 601PRO to the Host Computer</b></li><li><b>3. Receiving Device Information Records from the Host Computer</b></li><li><b>4. Device Information Record: Definition of Fields</b></li><li><b>5. Device Information Record Format</b></li><li><b>6. Deleting Device Records and Templates</b></li></ol> |
|--|

## 1. Connecting the 601PRO and the Host Computer

The serial port parameters of the 601PRO and those of the computer's communication program must match. Modify the 601PRO's baud rate at the **RS232** menu.

- From the **MAIN MENU**, press **SYSTEM SETUP**, then **RS232**.
- At the **RS232 Settings** menu, press a **SOFT KEY** to select a baud rate:

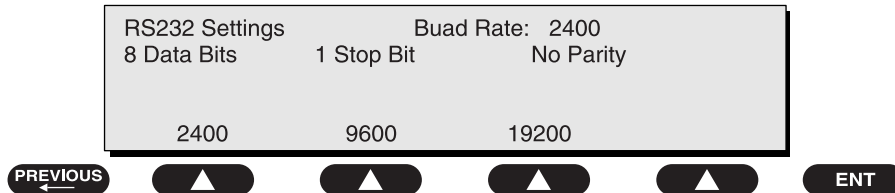

baw130f.eps

- Press **enter** to return to the **MAIN MENU**.
- **Note:** The communication program must have RTS/CTS handshaking selected or large file and higher baud rate transfers will fail.
- Power **DOWN** the 601PRO and the host computer.
- Attach one end of the serial cable to the back panel of the 601PRO.
- Attach the other end of the cable to the COM1 or COM2 port on the host computer.
- Power up the host computer and the 601PRO.
- Load the computer's communication program and enable it to receive (and save in a file if desired) the information about to be sent from the 601PRO.

## 2. Sending Device Information Records from the 601PRO to the Host Computer

- From the **MAIN MENU**, press **UTILITIES**, then **DEVICE RECORDS**, then **TRANSMIT RECORDS**.

- At the **Transmit Device Information** screen, press **START**.

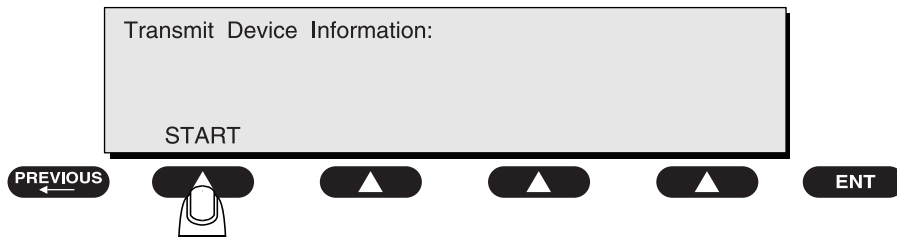

baw123f.eps

Transfer of the information should begin immediately. The following screen is displayed:

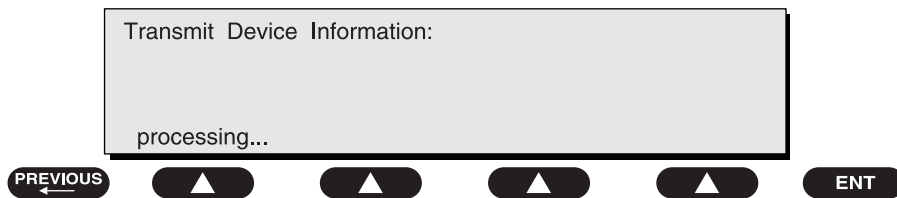

baw124f.eps

When finished, the 601PRO will return to the **Device Record Utility** menu. If there is a problem, an error message will be displayed.

### 3. Receiving Device Information Records from the Host Computer

Review *Section 1: Connecting the 601 and the Host*, and modify the 601PRO's baud rate if necessary.

- From the **MAIN MENU**, press **UTILITIES**, then **DEVICE RECORDS**, then **RECEIVE RECORDS**.
- At the **Receive Device Information** screen, press **START**.

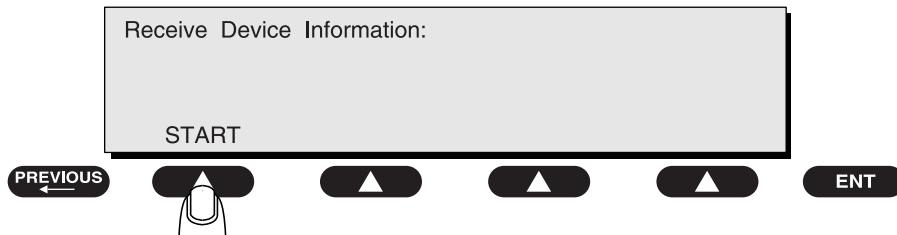

baw125f.eps

- Load the computer's communication program and enable it to send a device information file to the 601PRO. Transfer of the information should begin immediately. The following screen is displayed:

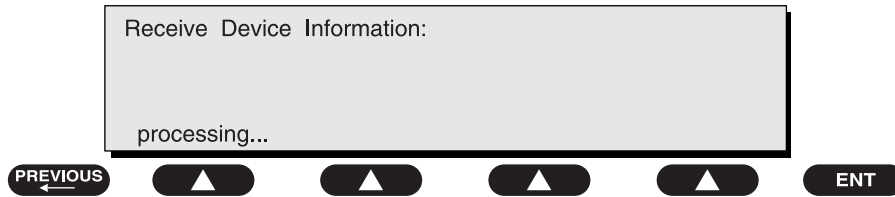

baw126f.eps

When device records are received by the 601PRO, existing records with the same control number as a record being received are overwritten; and records with new control numbers are added. When the device record storage is full, an error message will be displayed.

Device information records may be transferred from a file on a PC to the 601PRO from MS-DOS using the following steps:

- Set up the COM port for desired baud rate transfer. Type one of the following at the `c:\` prompts:
  - ⇒ `c:\> mode COM1,19,N,8,1,P` for 19200-baud transfer
  - ⇒ `c:\> mode COM1,96,N,8,1,P` for 9600-baud transfer
  - ⇒ `c:\> mode COM1,24,N,8,1,P` for 2400-baud transfer
- Transfer the file as follows:
  - ⇒ `c:\> copy file.txt COM1`

The 601PRO looks for an end-of-text character EOT (Ctrl-C or 03H) or end-of-file character (Ctrl-Z or 1AH) to terminate the transfer. If this character is not included in the file itself, the operator may have to cycle power on the 601PRO, or type "Ctrl -C" to end the transmission.

When finished, the 601PRO will return to the **Device Record Utility** menu.

**4. Device Information Record: Definition of Fields**

Field Name	Maximum Characters
CONTROL#:	(15)**
PROCEDURE ID:	(20)**
LOCATION:	(30)**
DEVICE TYPE:	(20)**
MANUFACTURER:	(25)**
SERIAL #:	(16)**
TECHNICIAN:	Empty field (was 5)*
DATE OF LAST TEST:	Empty field (was 8)*
CLASS:	(2)**
TYPE:	(2)**
TEST STANDARD:	(10)**
601-PRO SERIAL#:	Empty field (was 15)*
LEADS:	(1)**
LEAD1 AP:	(5)**
LEAD1 TYPE:	(2)**
LEAD2 AP:	(5)**
LEAD2 TYPE:	(2)**
LEAD3 AP:	(5)**
LEAD3 TYPE:	(2)**
LEAD4 AP:	(5)**
LEAD4 TYPE:	(2)**
LEAD5 AP:	(5)**
LEAD5 TYPE:	(2)**
POWER OFF DELAY:	(3)**
STARTUP DELAY:	(3)**
APPLIED CURRENT:	(2)**

\*These fields are present for compatibility with older versions of the 601PRO; and when received by the 601PRO Series<sub>XL</sub>, they are ignored. The 601PRO transmits them as empty fields.

\*\*Restrictions, interpretation, and defaults for these fields are described below:

- ⇒ Incoming device information records are checked for errors as follows: The order, number, and size of each field and record are fixed.
- ⇒ The Control Number must contain at least one character. The Test Standard must contain a valid entry. All other fields may be empty.
- ⇒ Valid Classes are I, (space)I, II, or IP.
- ⇒ Valid Types and Lead Types are B, BF, CF, T and F.

- ⇒ The Test Standard field must be an exact match with IEC 601-1, VDE 701, VDE 751.1, HEI 95, AAMI, IEC 1010, AS/NZS 3551, or the stored custom program names (CUSTOM1, CUSTOM2, CUSTOM3, CUSTOM4). An exact match includes spaces and punctuation marks, and is case sensitive.
- ⇒ If the standard is VDE 701, valid Types are T or F.
- ⇒ If the standard is IEC 601, HEI 95, VDE 751, AS/NZS 3551, or IEC 1010, valid Types are B, BF, or CF.
- ⇒ If the standard is AAMI, valid Class/Type combinations are I/B, I/BF, I/CF or II/B.
- ⇒ Valid Lead AP designations are RA, RL, LA, LL, or V1-V6. If the field is empty, it means that this Lead AP is not defined.
- ⇒ In Custom Standards, Class and Type are ignored; however, error checking for a match with whatever is there still occurs.
- ⇒ Valid Leads are 0, 1, 2, 3, 4, or 5.
- ⇒ Valid Power Off Delays and Startup Delays are 0 through 999. Leading zeros or spaces are ignored.
- ⇒ Applied Current must be 1, 10, or 25.

## 5. Device Information Record Format

Each field is surrounded by double quotes (“”) and separated by commas. A Carriage Return (ODH or Ctrl-M), but no comma appears after the last field in each record. An ETX character (03H or Ctrl-C) signals the end of the transmission by the 601PRO. An example of the Device Information format (export and import) is shown below. Fields in braces [] are present only for compatibility with older versions of the 601PRO and are ignored in the 601PRO series<sub>XL</sub>. The fields are described elsewhere in this chapter.

```
"control #", "Procedure ID", "Location", "Device
Type", "Manufacturer", "Serial #", "[compatibility-
nothing]", "[compatibility-nothing]", "Class", "Type", "Test
Standard", "[compatibility-nothing]", "# Leads", "Lead1 AP", "Lead1
Type", "Lead2 AP", "Lead2 Type", "Lead3 AP", "Lead3 Type", "Lead4
AP", "Lead4 Type", "Lead5 AP", "Lead5 Type", "Power Off Delay", "Startup
Delay", "Applied Current"<CR><ETX>
```

Example:

```
"CN123456", "Procedure23", "Upstairs", "DEFIB", "HEWLETT", "654987", "
", "", "II", "BF", "IEC 601-
1", "", "4", "RA", "BF", "RL", "BF", "LA", "CF", "LL", "CF", "", "", "5", "4", "25"<
CR><ETX>
```

## 6. Deleting Device Records and Templates

- From the **MAIN MENU**, press **UTILITIES**, then **DEVICE RECORDS** or **TEMPLATES**. Press **\*MORE** to display the following menu:

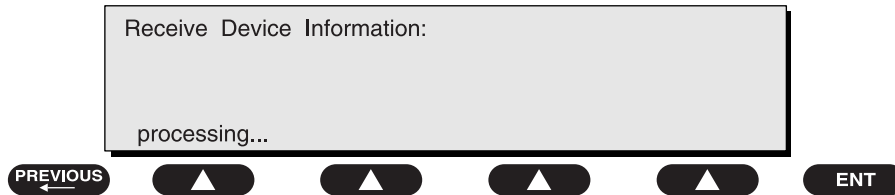

baw127f.eps

- Note:** The following steps and display examples are for **DEVICE RECORDS**. The steps are much the same when choosing **TEMPLATES** in the previous step. Just replace **TEMPLATE** for **RECORD** in each of the following displays. Also, **TEMPLATES** are identified by name instead of control number.

- To delete one device record on the 601PRO, press **DELETE RECORD**.
- Enter the **control number** for the Device Record to delete. Press **enter** when complete.

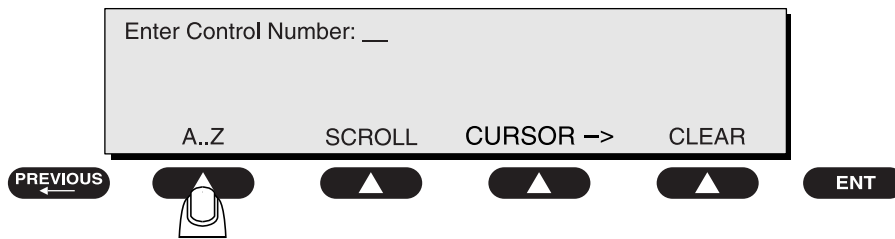

baw069f.eps

- To confirm deletion of the Device Record, press **YES**, or press **NO** to cancel deletion.

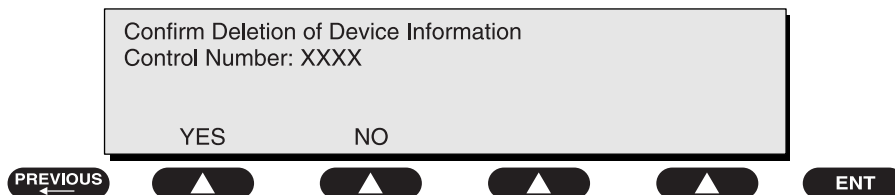

baw128f.eps

- Note:** Any test results associated with a single device record will be inaccessible for printing if the device record is deleted.

- To delete **all** device records on the 601PRO, press **DELETE ALL** at the **Device Record Utility** menu:

☛ **Note:** Deleting all records will remove both **DEVICE RECORDS** and **TEMPLATES** from the memory of the 601PRO.

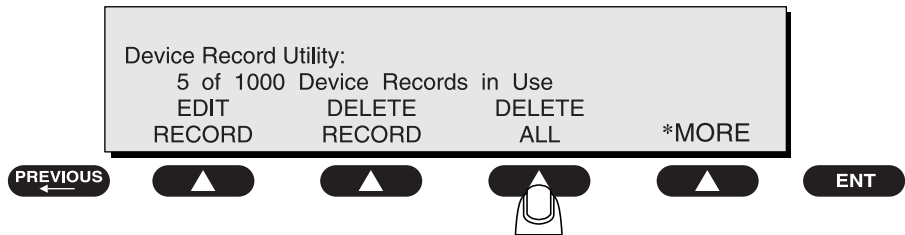

- To confirm deletion of **all** Device Records, press **YES**, or press **NO** to cancel deletion.

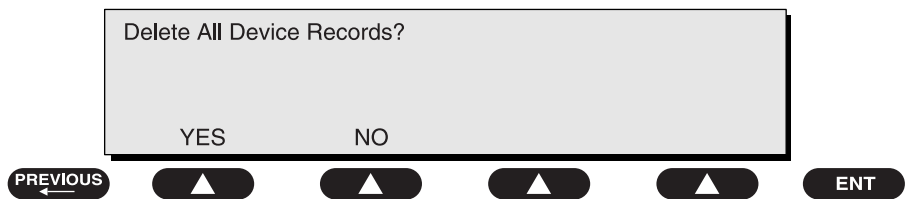

☛ **Note:** All result records must be deleted prior to this action (refer to *Chapter 5, Test Records*).

---

# Testing Devices

Chapter

7

This chapter provides instructions on how to use the 601PRO to perform routine testing on permanently wired, portable and battery-powered devices, as well as conductive surfaces and detachable power cords.

The testing devices listed below are detailed in this chapter:

- 1. Permanently Wired Devices**
- 2. Portable Devices**
- 3. Portable Devices in Isolated Power Systems**
- 4. Testing Three-Phase Portable Devices**
- 5. Testing Conductive Surfaces**
- 6. Detachable Power Supply Cable**
- 7. Battery-Powered Equipment**

## **1. Permanently Wired Devices**

When testing a permanently wired device, follow the procedure with the device off and then again with the device on.

Since the permanently wired device cannot be plugged into the 601PRO, the Safety Analyzer cannot be used to modify the receptacle configuration.

To test a permanently wired device:

1. Plug the 601PRO into a nearby outlet with the same earth as the device under test. Power up the 601PRO.
2. From the 601PRO **MAIN MENU**, select the appropriate Class/Type for the device under test.
3. Connect a test lead from the 601PRO's RED input jack to the chassis of the DUT.
4. Turn the DUT **off**.
5. Press the **Protective Earth Resistance** key on the 601PRO top panel.
6. Select the 1Amp current source to prevent damage in case one lead is connected to a functional earth.
7. Perform **Cal** if needed.
8. Connect another test lead from the 601PRO GREEN input jack to an earth point on the device under test.

9. Press the **Start Test** key to initiate the test. This is a point-to-point resistance measurement.
10. Make sure the reading is below 0.1 ohms.
11. Remove the lead connected to the GREEN jack and set aside.
12. Press the **Enclosure Leakage** key to run the **Enclosure Leakage Current** test.
13. Make sure the 601PRO front panel outlet is normal polarity, earthed, and L2 for appropriate limits.
14. Repeat the **Enclosure Leakage Current** test with the device under test **on**.

## 2. Portable Devices

Test the portable device as detailed in *Chapter 3, Manual Mode*, using procedures for **Manual**, **Automatic**, or **Step** modes.

## 3. Portable Devices Located in Isolated Power Systems

Portable devices located in isolated power systems should be tested on an earth-referenced power system.

Remove the DUT to an area with an earth-referenced power system. Or use an extension cord to bring earth-referenced power to the DUT.

## 4. Testing Three-Phase Portable Devices

When testing three-phase portable devices, the operator must be able to interrupt earth, L2, and reverse polarity. Three-phase equipment cannot be plugged directly into the 601PRO; an adapter that interrupts the earth, L2 and reverses polarity must be used.

1. Plug the device to be tested into an adapter that allows outlet configuration.
2. Plug the 601PRO into a nearby outlet or connect a cable from the protective earth connector on the back of the 601Pro to conductive surface with the same earth point as the device under test.
3. Connect a test lead from the RED input jack on the 601PRO to the enclosure (case) of the device.
4. Follow the **Manual** mode test procedures in *Chapter 3*. The adapter should be configured the same as the 601PRO for appropriate limits.

## 5. Testing Conductive Surfaces

1. Connect the RED test lead to the RED input terminal, and the BLACK test lead to the BLACK input terminal.
2. Press the **TESTS/AUTOMODES** key on the 601PRO.
3. Press the **MANUAL** key, then press **\*MORE** until the **DUAL LEAD LEAKAGE** menu is displayed.
4. Press **DUAL LEAD LEAKAGE**. The following menu is displayed:

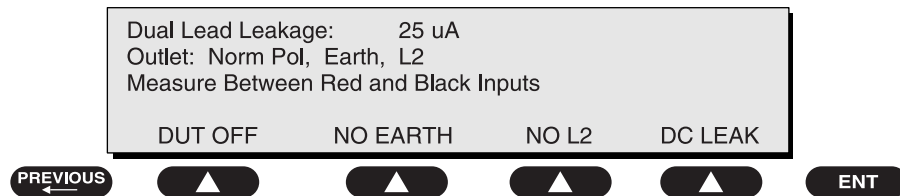

5. Measure point-to-point leakage between the RED and BLACK input jacks on the 601PRO.

baw111f.eps

## 6. Detachable Power Supply Cable

The 601PRO has an isolated measuring circuit that can measure differences between two points, independently of earth points.

1. Power up the 601PRO, and plug the detachable cable into the 601PRO Front Panel.
2. Connect the test lead from the RED input jack to earth of the detachable power supply cable.
3. Press the **Earth Resistance (shortcut key 3)**, and then select the test current as described in *Chapter 3*.
4. Press the **Earth Resistance** key once more to apply current.

The detachable power supply cable resistance should be less than 0.1 ohms.

## 7. Battery-Powered Equipment

1. Power up the 601PRO and connect a test lead from the GREEN input jack of the 601PRO to the enclosure (case) of the DUT.
2. Connect patient-applied leads to the applied part terminals on the 601PRO. Refer to the **Automatic** mode procedures in *Chapter 4, Auto/Step Modes*.
3. Power up the device under test.
4. Select Class IP (internally powered) and run an auto-sequence.

601PRO SERIES<sub>XL</sub>

---

# Standards and Principles

## Chapter

# 8

The 601PRO is programmed to use IEC 601-1 as the default test standard. Alternative test standards – VDE 751, VDE 701, HEI 95, IEC 1010, AAMI, AS/NZS 3551 and custom – are available for selection and can be accessed through **SYSTEM SETUP** from the **MAIN MENU**.

Some electrical tests may not be applicable under certain class/type categories (refer to the tables in this chapter). In these cases, the test will be performed but the test limit will display **Inv** (invalid).

To access the test standards, follow the steps outlined below.

- 1. Accessing System Setup**
- 2. Selecting the Test Standard**
- 3. Referring to Test Limits for the Selected Standard**

Standards and principles for each test may be found on the following pages:

VDE 701 and VDE 751-1	8-4
IEC 601-1 Controlled Power Sequence and Test Limits for Auto and Step Tests	8-5
IEC 601-1 Conventional Test Sequence and Test Limits for Auto and Step Tests	8-7
AAMI Controlled Power Sequence and Limits	8-10
IEC 1010 Controlled Power Sequence and Limits (IEC 61010-1, Second Ed.)	8-11
HEI 95 Controlled Power Sequence and Test Limits for Auto and Step Tests	8-12
HEI 95 Conventional Test Sequence and Test Limits for Auto and Step Tests	8-13
AS/NZS 3551 Test Sequence and Limits for Auto and Step Tests	8-14

Test Principle diagrams and notes may be found on the following pages:

Protective Earth Resistance	8-15
Earth Leakage Current	8-16
Enclosure Leakage Current	8-17
Mains Insulation Resistance	8-18
Applied Part Insulation Resistance	8-19
Mains on Applied Part	8-20
Patient Auxiliary Current	8-21
Patient Leakage Current	8-22
VDE, Equivalent Device Leakage	8-23
VDE, Equivalent Patient Leakage	8-24
Accessible Voltage	8-25
Accessible Leakage Current	8-26

**1. Accessing System Setup**

- From the 601PRO **MAIN MENU**, press **SYSTEM SETUP**:

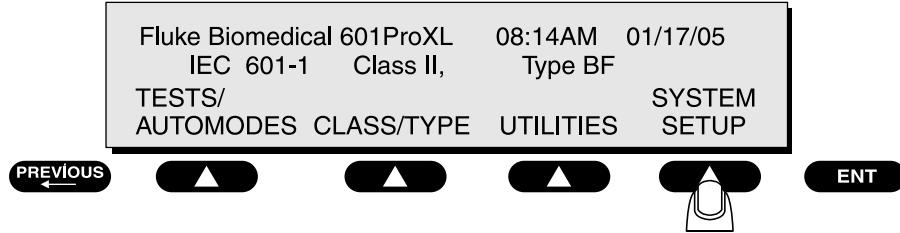

baw112f.eps

**2. Selecting the Test Standard**

- At the **Select Setup Function** menu, press **TEST STANDARD**:

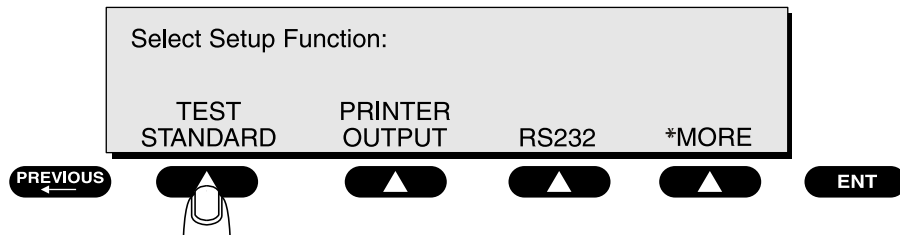

baw008f.eps

- At the **Select Test Standard** menu, use one of the **SOFT KEYS** to select a test standard, or press **\*MORE** for additional options.

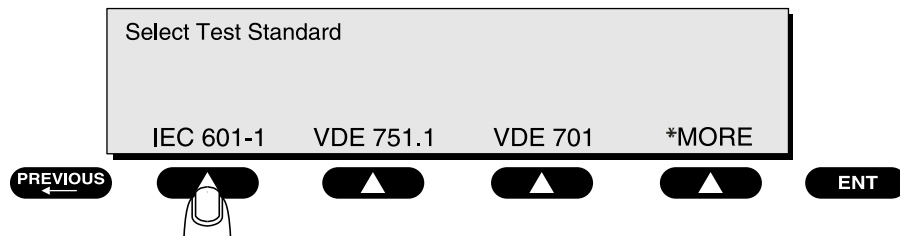

baw113f.eps

**Note:** Once the selection is made, the 601PRO will automatically return to the **MAIN MENU**.

**3. Referring to Test Limits for the Selected Standard**

Use the tables on pages 8-4 through 8-14 to refer to parameters and limits for the selected test standard.

**Manual Operation**

All manual tests are the same except for Leakage (referred to as Equivalent Device Leakage Current) and Patient Leakage (referred to as Equivalent Patient Leakage Current). The following tables detail VDE 701 and VDE 751-1 Test Limits for certain class/types.

The abbreviations are explained below:



- ⇒ NL: No limit. The unit will perform the test but will not apply pass/fail criteria.
  
- ⇒ NT: No test is available for this particular class/type. The unit will not take or store a reading and will not apply pass/fail criteria. In **Manual** mode and in **Computer Control** mode, the test limit will be displayed or printed as **Inv**.
  
- ⇒ N/A: Not applicable.

**VDE 701 and VDE 751-1**

VDE 701 and VDE 751 tests are specified for line voltages of >180V. Earth resistance test current is set to 25 A.

☛ **Note:** *The Equivalent Patient Leakage test is only performed for VDE 751-1.*

VDE 701 Standard	DUT OUTLET		Class I		Class II	
Description	Polarity	Circuit	T	F	T	F
Mains Voltage V	N/A	OFF	NL	NL	NL	NL
Earth Resistance $\Omega$	N/A	OFF	0.5	1	NT	NT
Equivalent Device Leakage $\mu$ A	N/A	OFF	7000	7000	7000	7000

VDE 751.1 Standard	DUT OUTLET		Class I			Class II		
Description	Polarity	Circuit	B	BF	CF	B	BF	CF
Line Voltage V	N/A	OFF	NL	NL	NL	NL	NL	NL
Protective Earth Resistance $\Omega$	N/A	OFF	0.2	0.2	0.2	NT	NT	NT
Equivalent Device Leakage $\mu$ A	N/A	OFF	1000	1000	1000	500	500	500
Equivalent Patient Leakage $\mu$ A	N/A	OFF	NT	5000	50	NT	5000	50

**Automatic Operation**

There is no change in device screens or comments during **AUTO** or **STEP** mode operation with VDE 751-1 and VDE 701. Test Limits are defined in the tables above.

**IEC 601-1 Controlled Power Sequence and Test Limits for Auto and Step Tests**

DC-Only tests will only be performed if DC readings are enabled. The types (B, BF, and CF) represent applied parts for Insulation Resistance, Patient Leakage Current, Patient Auxiliary, and Mains on Applied Part.

IEC 601-1 STANDARD DESCRIPTION	DUT OUTLET		CLASS I			CLASS II			CLASS IP		
	POLARIT Y	CIRCUIT	B	BF	CF	B	BF	CF	B	BF	CF
Line Voltage V	N/A	OFF	NL	NL	NL	NL	NL	NL	NT	NT	NT
Protective Earth Resistance $\Omega^{**}$	N/A	OFF	0.2	0.2	0.2	NT	NT	NT	NT	NT	NT
Insulation Resistance L1-L2-Case $M\Omega^{***}$	N/A	OFF	2	2	2	NT	NT	NT	NT	NT	NT
Insulation Resistance All Case $M\Omega$	N/A	OFF	NT	2	2	NT	NT	NT	NT	NT	NT
Startup Delay (Auto only)	Norm	Norm									
Current in L2 -- A	Norm	Norm	NL	NL	NL	NL	NL	NL	NT	NT	NT
Enclosure Leakage -- $\mu A$	Norm	Norm	100	100	100	100	100	100	NT	NT	NT
Patient Leakage Current -- $\mu A$	Norm	Norm	100	100	10	100	100	10	100	100	10
Patient Leakage Current -- $\mu A$ - DC Only	Norm	Norm	10	10	10	10	10	10	10	10	10
Patient Auxiliary -- $\mu A$	Norm	Norm	100	100	10	100	100	10	100	100	10
Patient Auxiliary -- $\mu A$ - DC Only	Norm	Norm	10	10	10	10	10	10	10	10	10
Mains on AP -- $\mu A$ ****	Norm	Norm	NT	5000	50	NT	5000	50	NT	5000	50
Earth Leakage -- $\mu A$	Norm	No E	500	500	500	NT	NT	NT	NT	NT	NT
Enclosure Leakage -- $\mu A$	Norm	No E	500	500	500	NT	NT	NT	NT	NT	NT
Patient Leakage Current -- $\mu A$	Norm	No E	500	500	50	NT	NT	NT	NT	NT	NT
Patient Leakage Current -- $\mu A$ - DC Only	Norm	No E	50	50	50	NT	NT	NT	NT	NT	NT
Patient Auxiliary -- $\mu A$	Norm	No E	500	500	50	NT	NT	NT	NT	NT	NT
Patient Auxiliary -- $\mu A$ - DC Only	Norm	No E	50	50	50	NT	NT	NT	NT	NT	NT
Power Off Delay	Norm	No L2 No E									
Earth Leakage -- $\mu A$	Norm	No L2 No E	1000	1000	1000	NT	NT	NT	NT	NT	NT
Enclosure Leakage -- $\mu A$	Norm	No L2	500	500	500	500	500	500	NT	NT	NT
Patient Leakage Current -- $\mu A$	Norm	No L2	500	500	50	500	500	50	NT	NT	NT
Patient Leakage Current -- $\mu A$ - DC Only	Norm	No L2	50	50	50	50	50	50	NT	NT	NT
Patient Auxiliary -- $\mu A$	Norm	No L2	500	500	50	500	500	50	NT	NT	NT
Patient Auxiliary -- $\mu A$ - DC Only	Norm	No L2	50	50	50	50	50	50	NT	NT	NT
Startup Delay	Reverse	Norm									
Enclosure Leakage -- $\mu A$	Reverse	Norm	100	100	100	100	100	100	NT	NT	NT
Patient Leakage Current -- $\mu A$	Reverse	Norm	100	100	10	100	100	10	NT	NT	NT
Patient Leakage Current -- $\mu A$ - DC Only	Reverse	Norm	10	10	10	10	10	10	NT	NT	NT
Patient Auxiliary -- $\mu A$	Reverse	Norm	100	100	10	100	100	10	NT	NT	NT
Patient Auxiliary -- $\mu A$ - DC Only	Reverse	Norm	10	10	10	10	10	10	NT	NT	NT
Mains on AP -- $\mu A$ *	Reverse	Norm	NT	5000	50	NT	5000	50	NT	NT	NT
Earth Leakage -- $\mu A$	Reverse	No E	500	500	500	NT	NT	NT	NT	NT	NT
Enclosure Leakage -- $\mu A$	Reverse	No E	500	500	500	NT	NT	NT	NT	NT	NT
Patient Leakage Current -- $\mu A$	Reverse	No E	500	500	50	NT	NT	NT	NT	NT	NT

**IEC 601-1 Controlled Power Sequence and Test Limits for Auto and Step Tests (Continued)**

IEC 601-1 STANDARD DESCRIPTION	DUT OUTLET		CLASS I			CLASS II			CLASS IP		
	POLARITY	CIRCUIT	B	BF	CF	B	BF	CF	B	BF	CF
Patient Leakage Current -- $\mu$ A – DC Only	Reverse	No E	50	50	50	NT	NT	NT	NT	NT	NT
Patient Auxiliary -- $\mu$ A	Reverse	No E	500	500	50	NT	NT	NT	NT	NT	NT
Patient Auxiliary -- $\mu$ A - DC Only	Reverse	No E	50	50	50	NT	NT	NT	NT	NT	NT
Power Off Delay	Reverse	No L2 No E									
Earth Leakage -- $\mu$ A	Reverse	No L2 No E	100 0	1000	1000	NT	NT	NT	NT	NT	NT
Enclosure Leakage -- $\mu$ A	Reverse	No L2	500	500	500	500	500	500	NT	NT	NT
Patient Leakage Current -- $\mu$ A	Reverse	No L2	500	500	50	500	500	50	NT	NT	NT
Patient Leakage Current -- $\mu$ A – DC Only	Reverse	No L2	50	50	50	50	50	50	NT	NT	NT
Patient Auxiliary -- $\mu$ A	Reverse	No L2	500	500	50	500	500	50	NT	NT	NT
Patient Auxiliary -- $\mu$ A - DC Only	Reverse	No L2	50	50	50	50	50	50	NT	NT	NT

\*This test takes one minute in **Step** mode.

\*\*The limit for Protective Earth Resistance is dependent upon the device under test:  $0.2\Omega$  for devices with a non-detachable power supply cord;  $0.1\Omega$  for devices with an appliance inlet.

\*\*\*Limits for Insulation Resistance are not specified in IEC 601-1.

\*\*\*\*Patient Leakage Current, Mains on Applied Part -- Normal Outlet is performed with NORMAL OUTLET polarity and both Normal and Reversed phase isolated 110% of mains. Patient Leakage Current, Mains on Applied Part -- Reversed Outlet are performed in the same manner as with a normal outlet except with REVERSE OUTLET polarity.

The limits have been removed for the Enclosure Leakage test with Class IP due to the fact that zero readings are always expected.

Delays are not applied to Class IP sequences.

**IEC 601-1 Conventional Test Sequence and Test Limits for Auto and Step Tests**

DC-Only tests will only be performed if DC readings are enabled. The types (B, BF, and CF) represent applied parts for Insulation Resistance, Patient Leakage Current, Patient Auxiliary, and Mains on Applied Part.

IEC 601-1 STANDARD DESCRIPTION	DUT OUTLET		CLASS I			CLASS II			CLASS IP		
	POLARITY	CIRCUIT	B	BF	CF	B	BF	CF	B	BF	CF
Line Voltage V	N/A	OFF	NL	NL	NL	NL	NL	NL	NT	NT	NT
Protective Earth Resistance $\Omega^{**}$	N/A	OFF	0.2	0.2	0.2	NT	NT	NT	NT	NT	NT
Insulation Resistance L1- L2- Case $M\Omega^{***}$	N/A	OFF	2	2	2	NT	NT	NT	NT	NT	NT
Insulation Resistance All Case $M\Omega$	N/A	OFF	NT	2	2	NT	NT	NT	NT	NT	NT
Startup Delay (Auto only)	Norm	Norm							N/A	N/A	N/A
Current in L2 -- A	Norm	Norm	NL	NL	NL	NL	NL	NL	NT	NT	NT
Earth Leakage -- $\mu A$	Norm	No E	500	500	500	NT	NT	NT	NT	NT	NT
Power Off Delay	Norm	No L2 No E				N/A	N/A	N/A	N/A	N/A	N/A
Earth Leakage -- $\mu A$	Norm	No L2 No E	1000	1000	1000	NT	NT	NT	NT	NT	NT
Startup Delay (Auto only)	Reverse	No E				N/A	N/A	N/A	N/A	N/A	N/A
Earth Leakage -- $\mu A$	Reverse	No E	500	500	500	NT	NT	NT	NT	NT	NT
Power Off Delay	Reverse	No L2 No E				N/A	N/A	N/A	N/A	N/A	N/A
Earth Leakage -- $\mu A$	Reverse	No L2 No E	1000	1000	1000	NT	NT	NT	NT	NT	NT
Startup Delay (Auto only)	Norm	Norm				N/A	N/A	N/A	N/A	N/A	N/A
Enclosure Leakage -- $\mu A$	Norm	Norm	100	100	100	100	100	100	NT	NT	NT
Power Off Delay	Norm	No L2							N/A	N/A	N/A
Enclosure Leakage -- $\mu A$	Norm	No L2	500	500	500	500	500	500	NT	NT	NT
Startup Delay	Norm	No E				N/A	N/A	N/A	N/A	N/A	N/A
Enclosure Leakage -- $\mu A$	Norm	No E	500	500	500	NT	NT	NT	NT	NT	NT
Power Off Delay	N/A	OFF							N/A	N/A	N/A
Startup Delay (Auto only)	Reverse	Norm							N/A	N/A	N/A
Enclosure Leakage -- $\mu A$	Reverse	Norm	100	100	100	100	100	100	NT	NT	NT
Power Off Delay	Reverse	No L2							N/A	N/A	N/A
Enclosure Leakage -- $\mu A$	Reverse	No L2	500	500	500	500	500	500	NT	NT	NT
Startup Delay	Reverse	No E				N/A	N/A	N/A	N/A	N/A	N/A
Enclosure Leakage -- $\mu A$	Reverse	No E	500	500	500	NT	NT	NT	NT	NT	NT
Power Off Delay	N/A	OFF							N/A	N/A	N/A
Startup Delay (Auto only)	Norm	Norm							N/A	N/A	N/A
Patient Leakage Current - $\mu A$	Norm	Norm	100	100	10	100	100	10	100	100	10
Power Off Delay	Norm	No L2							N/A	N/A	N/A
Patient Leakage Current - $\mu A$	Norm	No L2	500	500	50	500	500	50	NT	NT	NT
Startup Delay	Norm	No E				N/A	N/A	N/A	N/A	N/A	N/A
Patient Leakage Current - $\mu A$	Norm	No E	500	500	50	NT	NT	NT	NT	NT	NT
Power Off Delay	N/A	OFF							N/A	N/A	N/A
Startup Delay (Auto only)	Reverse	Norm							N/A	N/A	N/A
Patient Leakage Current - $\mu A$	Reverse	Norm	100	100	10	100	100	10	NT	NT	NT
Power Off Delay	Reverse	No L2							N/A	N/A	N/A
Patient Leakage Current - $\mu A$	Reverse	No L2	500	500	50	500	500	50	NT	NT	NT

**IEC 601-1 Conventional Test Sequence and Test Limits for Auto and Step Tests (Continued)**

IEC 601-1 STANDARD DESCRIPTION	DUT OUTLET		CLASS I			CLASS II			CLASS IP		
	POLARITY	CIRCUIT	B	BF	CF	B	BF	CF	B	BF	CF
Startup Delay	Reverse	No E				N/A	N/A	N/A	N/A	N/A	N/A
Patient Leakage Current - - μA	Reverse	No E	500	500	50	NT	NT	NT	NT	NT	NT
Power Off Delay	N/A	OFF							N/A	N/A	N/A
Startup Delay (Auto only)	Norm	Norm							N/A	N/A	N/A
Patient Leakage Current - - μA -DC Only	Norm	Norm	10	10	10	10	10	10	10	10	10
Power Off Delay	Norm	No L2							N/A	N/A	N/A
Patient Leakage Current - - μA -DC Only	Norm	No L2	50	50	50	50	50	50	NT	NT	NT
Startup Delay	Norm	No E				N/A	N/A	N/A	N/A	N/A	N/A
Patient Leakage Current - - μA -DC Only	Norm	No E	50	50	50	NT	NT	NT	NT	NT	NT
Power Off Delay	N/A	OFF							N/A	N/A	N/A
Startup Delay (Auto only)	Reverse	Norm							N/A	N/A	N/A
Patient Leakage Current - - μA -DC Only	Reverse	Norm	10	10	10	10	10	10	NT	NT	NT
Power Off Delay	Reverse	No L2							N/A	N/A	N/A
Patient Leakage Current - - μA -DC Only	Reverse	No L2	50	50	50	50	50	50	NT	NT	NT
Startup Delay	Reverse	No E				N/A	N/A	N/A	N/A	N/A	N/A
Patient Leakage Current - - μA -DC Only	Reverse	No E	50	50	50	NT	NT	NT	NT	NT	NT
Power Off Delay	N/A	OFF							N/A	N/A	N/A
Startup Delay (Auto only)	Norm	Norm							N/A	N/A	N/A
Mains on AP -- μA ****	Norm	Norm	NT	5000	50	NT	5000	50	5000	5000	50
Power Off Delay	N/A	OFF							N/A	N/A	N/A
Startup Delay (Auto only)	Reverse	Norm							N/A	N/A	N/A
Mains on AP -- μA *	Reverse	Norm	NT	5000	50	NT	5000	50	NT	NT	NT
Power Off Delay	N/A	OFF							N/A	N/A	N/A
Startup Delay (Auto only)	Norm	Norm							N/A	N/A	N/A
Patient Auxiliary -- μA	Norm	Norm	100	100	10	100	100	10	100	100	10
Power Off Delay	Norm	No L2							N/A	N/A	N/A
Patient Auxiliary -- μA	Norm	No L2	500	500	50	500	500	50	NT	NT	NT
Startup Delay	Norm	No E				N/A	N/A	N/A	N/A	N/A	N/A
Patient Auxiliary -- μA	Norm	No E	500	500	50	NT	NT	NT	NT	NT	NT
Power Off Delay	N/A	OFF							N/A	N/A	N/A
Startup Delay (Auto only)	Reverse	Norm							N/A	N/A	N/A
Patient Auxiliary -- μA	Reverse	Norm	100	100	10	100	100	10	NT	NT	NT
Power Off Delay	Reverse	No L2							N/A	N/A	N/A
Patient Auxiliary -- μA	Reverse	No L2	500	500	50	500	500	50	NT	NT	NT
Startup Delay	Reverse	No E				N/A	N/A	N/A	N/A	N/A	N/A
Patient Auxiliary -- μA	Reverse	No E	500	500	50	NT	NT	NT	NT	NT	NT
Power Off Delay	N/A	OFF							N/A	N/A	N/A
Startup Delay (Auto only)	Norm	Norm							N/A	N/A	N/A
Patient Auxiliary -- μA DC Only	Norm	Norm	10	10	10	10	10	10	10	10	10
Power Off Delay	Norm	No L2							N/A	N/A	N/A
Patient Auxiliary -- μA DC Only	Norm	No L2	50	50	50	50	50	50	NT	NT	NT
Startup Delay	Norm	No E				N/A	N/A	N/A	N/A	N/A	N/A
Patient Auxiliary -- μA DC Only	Norm	No E	50	50	50	NT	NT	NT	NT	NT	NT
Power Off Delay	N/A	OFF							N/A	N/A	N/A
Startup Delay (Auto only)	Reverse	Norm							N/A	N/A	N/A
Patient Auxiliary -- μA DC Only	Reverse	Norm	10	10	10	10	10	10	NT	NT	NT

**IEC 601-1 Conventional Test Sequence and Test Limits for Auto and Step Tests (Continued)**

IEC 601-1 STANDARD DESCRIPTION	POLARITY	CIRCUIT	CLASS I			CLASS II			CLASS IP		
			B	BF	CF	B	BF	CF	B	BF	CF
Power Off Delay	Reverse	No L2							N/A	N/A	N/A
Patient Auxiliary -- $\mu$ A DC Only	Reverse	No L2	50	50	50	50	50	50	NT	NT	NT
Startup Delay	Reverse	No E				N/A	N/A	N/A	N/A	N/A	N/A
Patient Auxiliary -- $\mu$ A DC Only	Reverse	No E	50	50	50	NT	NT	NT	NT	NT	NT

\*This test takes one minute in **Step** mode.

\*\*The limit for Protective Earth Resistance is dependent upon the device under test:  $0.2\Omega$  for devices with a non-detachable power supply cord;  $0.1\Omega$  for devices with an appliance inlet.

\*\*\*Limits for Insulation Resistance are not specified in IEC 601-1.

\*\*\*\*Patient Leakage Current, Mains on Applied Part -- Normal Outlet is performed with NORMAL OUTLET polarity and both Normal and Reversed phase isolated 110% of mains. Patient Leakage Current, Mains on Applied Part -- Reversed Outlet is performed in the same manner as with a normal outlet except with REVERSE OUTLET polarity.

The limits have been removed for the Enclosure Leakage test with Class IP due to the fact that zero readings are always expected.

Delays are not applied to Class IP sequences.

**AAMI Controlled Power Sequence and Limits**

AAMI STANDARD TESTS	DUT OUTLET		IEC 601 CLASS/TYPE & AAMI CATEGORY*			
			I/B	I/BF	I/CF	I/B
DESCRIPTION	POLARITY	CIRCUIT	NON-ISOLATE	LIKELY CONTACT	ISOLATE	NO CONTACT
Line Voltage V	N/A	OFF	NL	NL	NL	NL
Ground Wire $\Omega$ **	N/A	OFF	0.2	0.2	0.2	NT
Startup Delay (auto only)	Norm	Norm				
L2 Current A	Norm	Norm	NL	NL	NL	NL
Enclosure $\mu$ A	Norm	Norm	100	100	1003	100
AP – Gnd $\mu$ A	Norm	Norm	10	NT	10	NT
Interlead $\mu$ A	Norm	Norm	10	NT	10	NT
AP sink $\mu$ A ***	Norm	Norm	NT	NT	50	NT
Earth $\mu$ A	Norm	No E	500	500	500	500
Enclosure $\mu$ A	Norm	No E	300	300	300	500
AP – Gnd $\mu$ A	Norm	No E	100	NT	50	NT
Interlead $\mu$ A	Norm	No E	100	NT	50	NT
Power OFF Delay	Norm	No L2 No E				
Earth $\mu$ A	Norm	No L2 No E	1000	1000	1000	1000
Startup Delay (auto only)	Reverse	Norm				
Enclosure $\mu$ A	Reverse	Norm	100	100	100	100
AP – Gnd $\mu$ A	Reverse	Norm	10	NT	10	NT
Interlead $\mu$ A	Reverse	Norm	10	NT	10	NT
Earth $\mu$ A	Reverse	No E	500	500	500	500
Enclosure $\mu$ A	Reverse	No E	300	300	300	500
AP – Gnd $\mu$ A	Reverse	No E	100	NT	50	NT
Interlead $\mu$ A	Reverse	No E	100	NT	50	NT
Power OFF Delay	Reverse	No L2 No E				
Earth $\mu$ A	Reverse	No L2 No E	1000	1000	1000	1000

\*In the AAMI Test Standard, the IEC 601 Class and Type designations have no meaning other than to select the AAMI Category as shown in the table. The AAMI test limits in this table are for General Cord Connected Equipment Only.

\*\*Not specified by AAMI/ANSI – The limit shown for IEC 601-1 for Protective Earth Resistance is dependent upon the device under test: 0.2 $\Omega$  for devices with a non-detachable power supply cord; 0.1 $\Omega$  for devices with an appliance inlet.

\*\*\*Mains on AP – Is performed with NORMAL OUTLET polarity and both Normal and Reversed phase of the isolated mains. The test is not done in the single fault condition as required by AAMI/ANSI, nor is there a 120 K $\Omega$  resistance in series with the isolated source.

In the AAMI Test Standard, it is possible to get an **Inv** limit in the Interlead tests if using multiple type lead definitions. If this occurs, check the definition of the leads in the Device Information Record.

**IEC 1010 Controlled Power Sequence and Limits (Reflects IEC 61010-1 Second Edition, 2001-2002)**

IEC 1010 STANDARD			CLASS I	CLASS II
DESCRIPTION	POLARITY	CIRCUIT		
Line Voltage V	N/A	N/A	NL	NL
Earth Resistance $\Omega$ @25A	N/A	OFF	0.2	NT
Startup Delay (auto only)	Norm	Norm		
Accessible Voltage RMS	Norm	Norm	33	33
Accessible Leakage RMS $\mu$ A	Norm	Norm	500	500
Accessible Leakage DC $\mu$ A	Norm	Norm	2000	2000
Accessible Voltage RMS	Norm	No E	55	55
Accessible Leakage RMS $\mu$ A	Norm	No E	3500	3500
Accessible Leakage DC $\mu$ A	Norm	No E	15000	15000
Power OFF Delay	Norm	No L2		
Accessible Voltage RMS	Norm	No L2	55	55
Accessible Leakage RMS $\mu$ A	Norm	No L2	3500	3500
Accessible Leakage DC $\mu$ A	Norm	No L2	15000	15000
Startup Delay (auto only)	Rev	Norm		
Accessible Voltage RMS	Rev	Norm	33	33
Accessible Leakage RMS $\mu$ A	Rev	Norm	500	500
Accessible Leakage DC $\mu$ A	Rev	Norm	2000	2000
Accessible Voltage RMS	Rev	No E	55	55
Accessible Leakage RMS $\mu$ A	Rev	No E	3500	3500
Accessible Leakage DC $\mu$ A	Rev	No E	15000	15000
Power OFF Delay	Rev	No L2		
Accessible Voltage RMS	Rev	No L2	55	55
Accessible Leakage RMS $\mu$ A	Rev	No L2	3500	3500
Accessible Leakage DC $\mu$ A	Rev	No L2	15000	15000

**NOTE:** The Class/Type information is not part of the IEC 1010-1 specification; hence, with the exception of Earth Resistance, the tests and limits are the same for all Classes. The device only fails if the Accessible Voltage and Leakage are above the set limits.

Accessible Leakage RMS/DC is the same as Enclosure Leakage in IEC 601 terminology.

The limit for Protective Earth Resistance is specified as  $0.1\Omega$  *without* the mains cord impedance. Test the mains cord separately or do the lead offset (calibration) through the mains cord. To do the specified one-minute test, **Manual** mode must be used.

Data is assessed based on the outlet configuration. The only requirement is for one of the three readings, Accessible Voltage, Accessible Leakage RMS, or Accessible Leakage DC, to pass for a given outlet configuration. Alternatively stated, all three of these tests must fail for the same outlet configuration to fail a test.

**HEI 95 Controlled Power Sequence and Test Limits for Auto and Step Tests**

DC-Only tests will only be performed if DC readings are enabled. The types (B, BF, and CF) represent applied parts for Insulation Resistance, Patient Leakage Current, Patient Auxiliary, and Mains on Applied Part.

HEI-95 STANDARD DESCRIPTION	DUT OUTLET		CLASS I			CLASS II		
	POLARITY	CIRCUIT	B	BF	CF	B	BF	CF
Protective Earth Resistance $\Omega$	N/A	OFF	0.2	0.2	0.2	NT	NT	NT
Insulation Resistance L1-L2- Case $M\Omega$	N/A	OFF	50	50	50	NT	NT	NT
Insulation Resistance All-Case $M\Omega$	N/A	OFF	NT	50	50	NT	NT	NT
Startup Delay (Auto only)	Norm	Norm						
Enclosure Leakage $\mu A$	Norm	Norm	500	500	500	100	100	10
Patient Leakage Current $\mu A$	Norm	Norm	500	500	50	100	100	10
Patient Leakage Current $\mu A$ – DC Only	Norm	Norm	500	500	50	100	100	10
Earth Leakage $\mu A$	Norm	No E	500	500	500	NT	NT	NT
Enclosure Leakage $\mu A$	Norm	No E	500	500	500	NT	NT	NT
Patient Leakage Current $\mu A$	Norm	No E	500	500	50	NT	NT	NT
Patient Leakage Current $\mu A$ – DC Only	Norm	No E	500	500	50	NT	NT	NT
Power Off Delay	Norm	No L2						
Startup Delay (Auto only)	Reverse	Norm						
Enclosure Leakage $\mu A$	Reverse	Norm	500	500	500	100	100	10
Patient Leakage Current $\mu A$	Reverse	Norm	500	500	50	100	100	10
Patient Leakage Current $\mu A$ – DC Only	Reverse	Norm	500	500	50	100	100	10
Earth Leakage $\mu A$	Reverse	No E	500	500	500	NT	NT	NT
Enclosure Leakage $\mu A$	Reverse	No E	500	500	500	NT	NT	NT
Patient Leakage Current $\mu A$	Reverse	No E	500	500	50	NT	NT	NT
Patient Leakage Current $\mu A$ – DC Only	Reverse	No E	500	500	50	NT	NT	NT

**HEI 95 Conventional Test Sequence and Test Limits for Auto and Step Tests**

DC-Only tests will only be performed if DC readings are enabled. The types (B, BF, and CF) represent applied parts for Insulation Resistance, Patient Leakage Current, Patient Auxiliary, and Mains on Applied Part.

HEI-95 STANDARD DESCRIPTION	DUT OUTLET		CLASS I			CLASS II		
	POLARITY	CIRCUIT	B	BF	CF	B	BF	CF
Protective Earth Resistance $\Omega$	N/A	OFF	0.2	0.2	0.2	NT	NT	NT
Insulation Resistance L1-L2- Case $M\Omega$	N/A	OFF	50	50	50	NT	NT	NT
Insulation Resistance All-Case $M\Omega$	N/A	OFF	NT	50	50	NT	NT	NT
Startup Delay	Norm	No E				N/A	N/A	N/A
Earth Leakage $\mu A$	Norm	No E	500	500	500	NT	NT	NT
Power Off Delay	N/A	OFF				N/A	N/A	N/A
Startup Delay	Reverse	No E				N/A	N/A	N/A
Earth Leakage $\mu A$	Reverse	No E	500	500	500	NT	NT	NT
Power Off Delay	N/A	OFF				N/A	N/A	N/A
Startup Delay	Norm	Norm						
Enclosure Leakage $\mu A$	Norm	Norm	500	500	500	100	100	10
Enclosure Leakage $\mu A$	Norm	No E	500	500	500	NT	NT	NT
Power Off Delay	N/A	OFF						
Startup Delay	Reverse	Norm						
Enclosure Leakage $\mu A$	Reverse	Norm	500	500	500	100	100	10
Enclosure Leakage $\mu A$	Reverse	No E	500	500	500	NT	NT	NT
Power Off Delay	N/A	OFF						
Startup Delay	Norm	Norm						
Patient Leakage Current $\mu A$	Norm	Norm	500	500	50	100	100	10
Patient Leakage Current $\mu A$	Norm	No E	500	500	50	NT	NT	NT
Power Off Delay	N/A	OFF						
Startup Delay	Reverse	Norm						
Patient Leakage Current $\mu A$	Reverse	Norm	500	500	50	100	100	10
Patient Leakage Current $\mu A$	Reverse	No E	500	500	50	NT	NT	NT
Power Off Delay	N/A	OFF						
Startup Delay (Auto only)	Norm	Norm						
Patient Leakage Current $\mu A$ – DC Only	Norm	Norm	500	500	50	100	100	10
Patient Leakage Current $\mu A$ – DC Only	Norm	No E	500	500	50	NT	NT	NT
Power Off Delay	N/A	OFF						
Startup Delay (Auto only)	Reverse	Norm						
Patient Leakage Current $\mu A$ – DC Only	Reverse	Norm	500	500	50	100	100	10
Patient Leakage Current $\mu A$ – DC Only	Reverse	No E	500	500	50	NT	NT	NT

**AS/NZS 3551 Controlled Power Sequence and Test Limits for Auto and Step Tests**

AS/NZS 3551 STANDARD	DUT OUTLET		CLASS I			CLASS II			CLASS IP		
	DESCRIPTION	POLARITY	CIRCUIT	B	BF	CF	B	BF	CF	B	BF
Line Voltage V	N/A	OFF	NL	NL	NL	NL	NL	NL	NT	NT	NT
Protective Earth Resistance $\Omega^*$	N/A	OFF	0.2	0.2	0.2	NT	NT	NT	NT	NT	NT
Insulation Resistance L1-L2-Case $M\Omega^{**}$	N/A	OFF	1.0	1.0	1.0	1.0	1.0	1.0	NT	NT	NT
Startup Delay (Auto only)	Norm	Norm									
Current in L2 -- A	Norm	Norm	NL	NL	NL	NL	NL	NL	NT	NT	NT
Patient Leakage Current -- $\mu A$	Norm	Norm	100	100	10	100	100	10	100	100	10
Mains on AP -- $\mu A$	Norm	Norm	NT	5000	50	NT	5000	50	NT	5000	50
Earth Leakage -- $\mu A$	Norm	No E	500	500	500	NT	NT	NT	NT	NT	NT
Patient Leakage Current-- $\mu A$	Norm	No E	500	500	50	NT	NT	NT	NT	NT	NT
Power Off Delay	Norm	No L2 No E									
Earth Leakage -- $\mu A$	Norm	No L2 No E	1000	1000	1000	NT	NT	NT	NT	NT	NT
Patient Leakage Current-- $\mu A$	Norm	No L2	100	100	10	100	100	10	NT	NT	NT

\*Testing should be done using 1 Amp.

\*\*The Insulation Resistance L1-L2 - Case test is the Insulation Resistance L1-L2 – Protective Earth test as described in AS/NZS 3551:1996 section 5.3.3 *Insulation Resistance* test condition 1. The L1-L2 – Enclosure (test condition 2) is not performed due to hardware limitations.

## Test Principle: Protective Earth Resistance

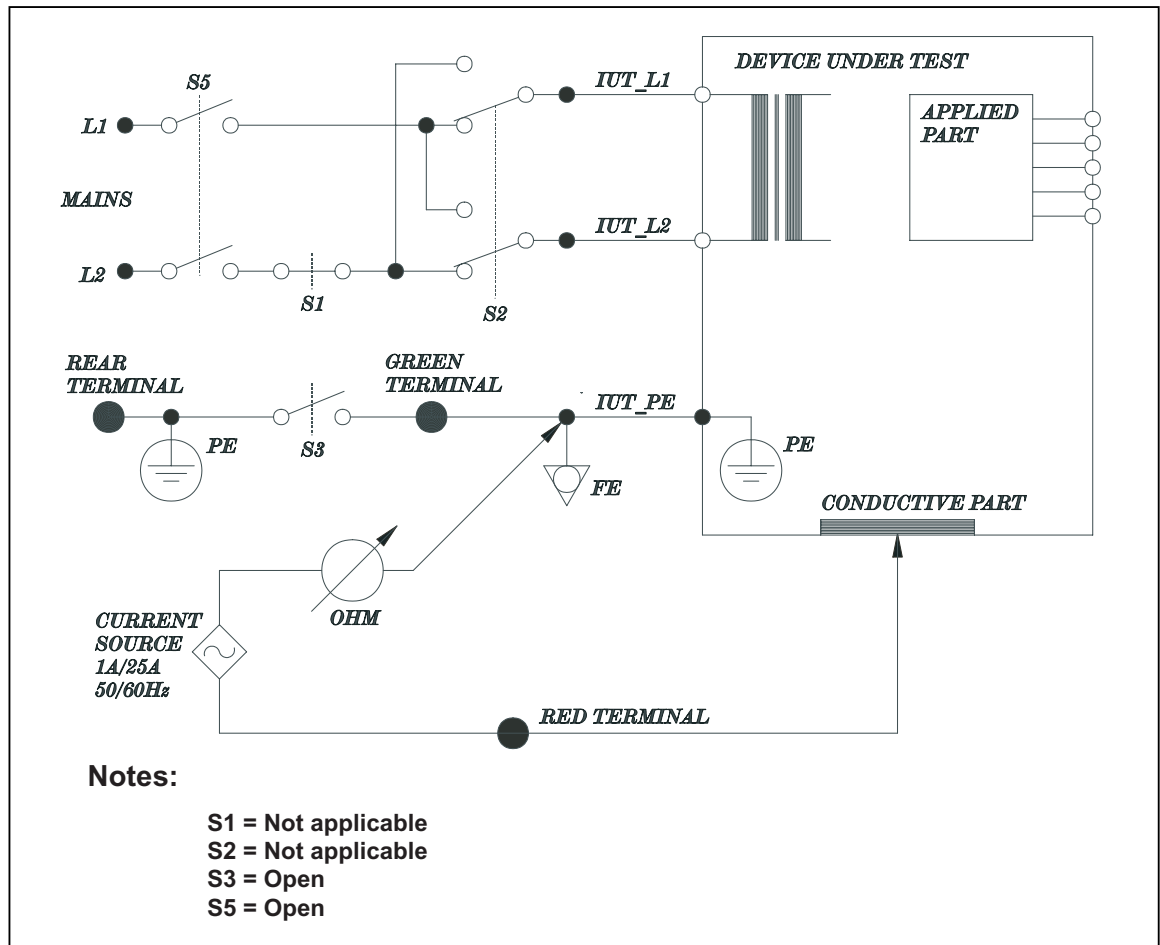

baw137f.eps

**Function:** Measures the impedance between the 601PRO's outlet PE terminal and exposed conductive parts of the DUT that are connected to the DUT's protective earth. Test current is applied for approximately 5 seconds.

**Applicable to:**

IEC 601-1, Class I:	Current source = 25 A $\pm$ 10%
VDE 751-1, Class I:	Current source = 5-25 A
HEI 95, Class I:	Current source = 1 A
VDE 701, Class I:	Current source = 1 A
IEC 1010, Class I:	Current source = 1 A
AAMI:	Current source = 1 A
AS/NZS 3551:	Current source = 1 A

**Test Principle: Earth Leakage Current**

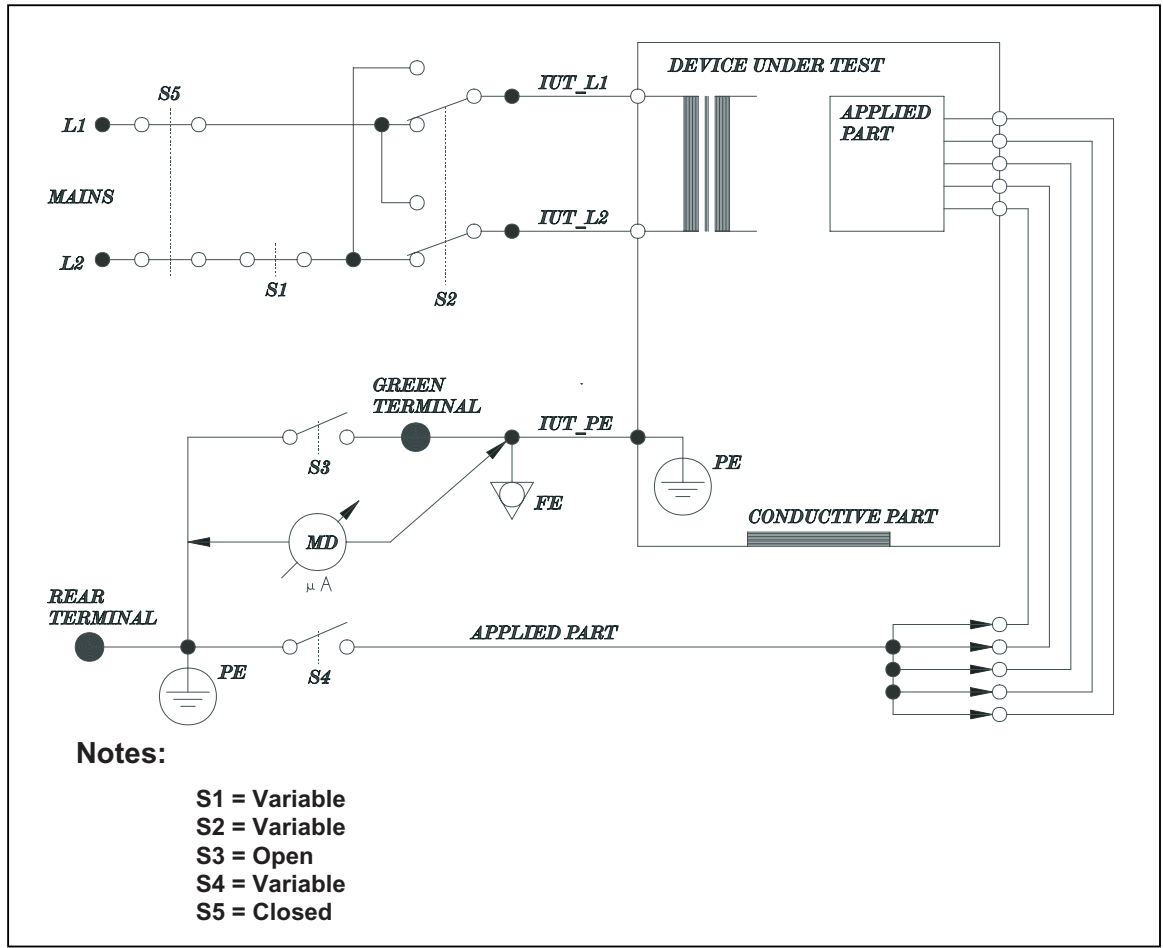

baw136f.eps

<b>Function:</b>	Measures the current flowing in the DUT's PE. The test is performed with normal and reverse mains supply polarity using S2, and single fault condition open L2 using S1. For type BF and type CF equipment, measure with applied part to ground switch S4 open and closed.
<b>Applicable to:</b>	IEC 601-1, Class I HEI 95, Class I AAMI AS/NZS 3551, Class I

### Test Principle: Enclosure Leakage Current

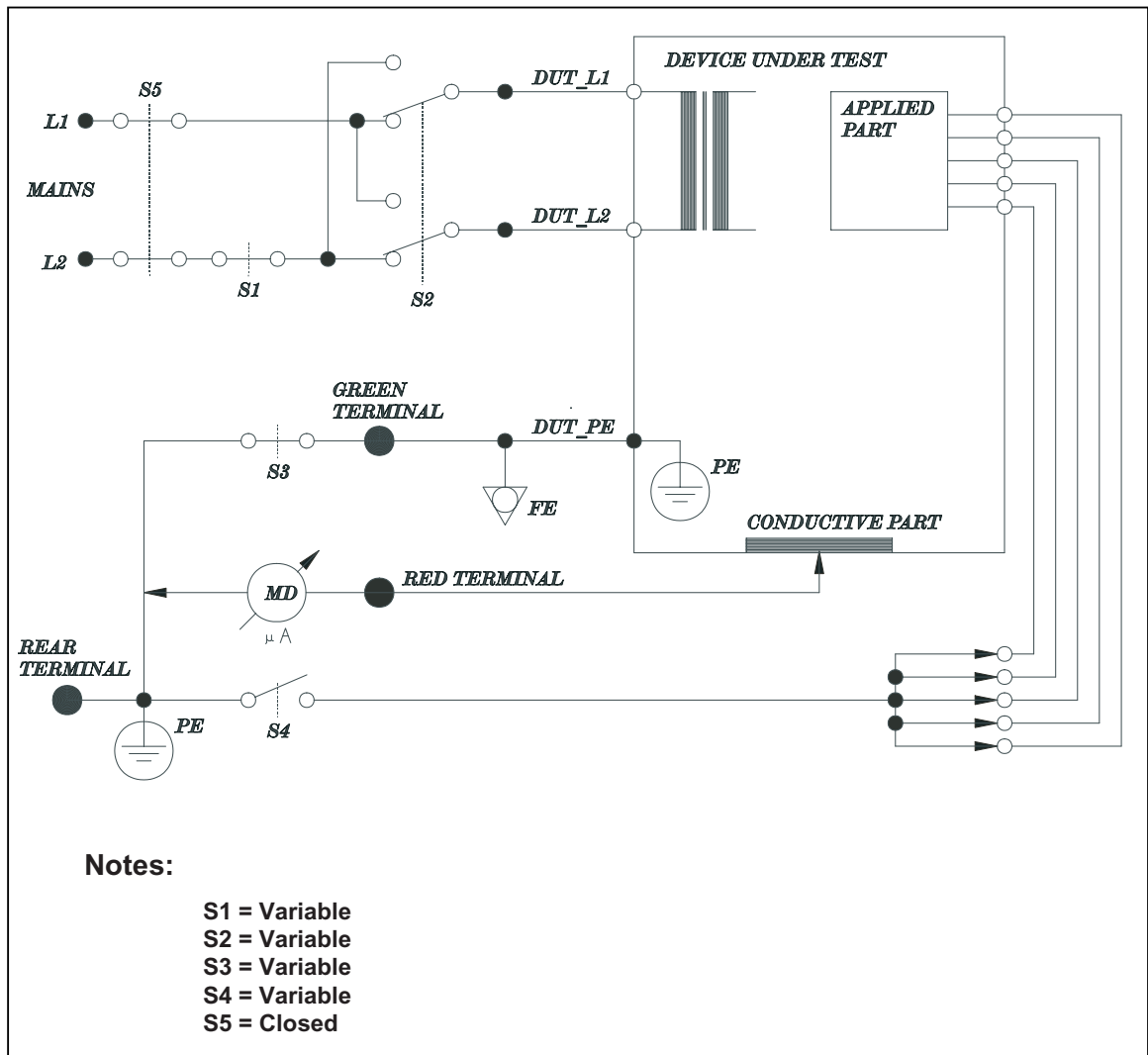

baw139f.eps

**Function:** Measures the current flowing from the RED TERMINAL to MAINS PE. Test is performed with normal and reverse mains supply polarity using S2, single fault condition open L2 using S1, and open earth using S3. For types BF and CF equipment, measure with applied part to ground switch S4 open and closed.

**Applicable to:** IEC 1010 (Accessible Leakage)  
IEC 601-1, Class I\*  
HEI 95, Class I\*  
AAMI\*

\*Enclosure Leakage

**Test Principle: Mains Insulation Resistance**

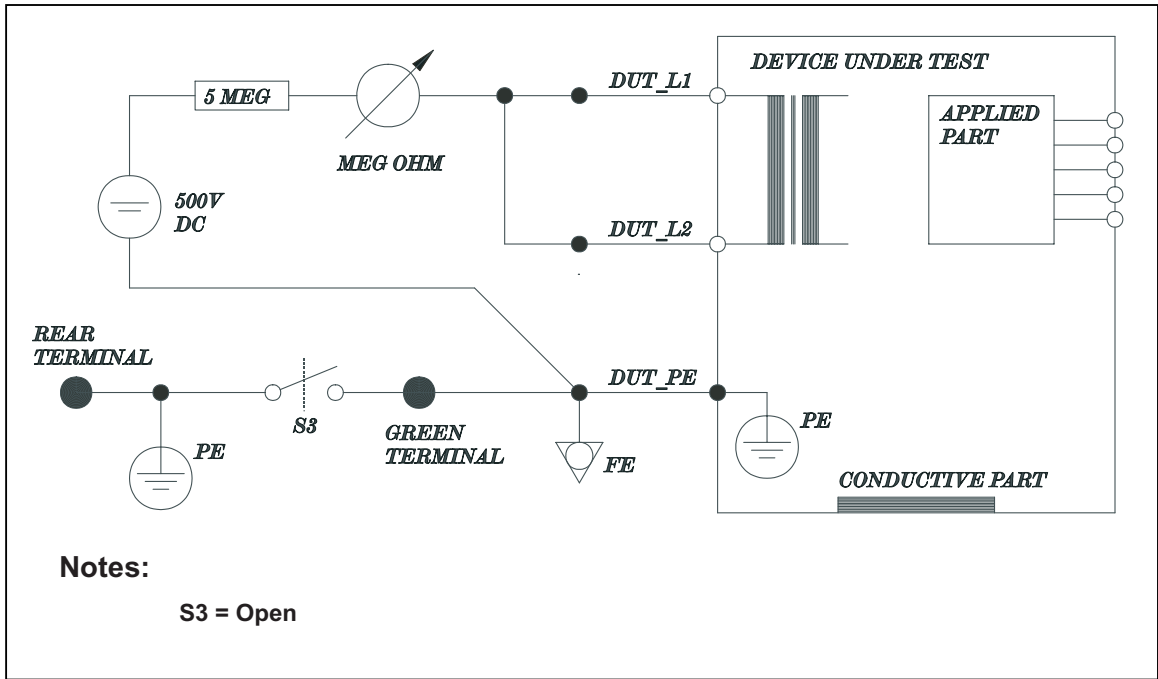

baw140f.eps

<b>Function:</b>	Measures the insulation resistance (at 500 VDC) between L1 and L2 and DUT PE.
<b>Applicable to:</b>	IEC 601-1, Class I HEI 95, Class I AS/NZS 3551, Class I

### Test Principle: Applied Part Insulation Resistance

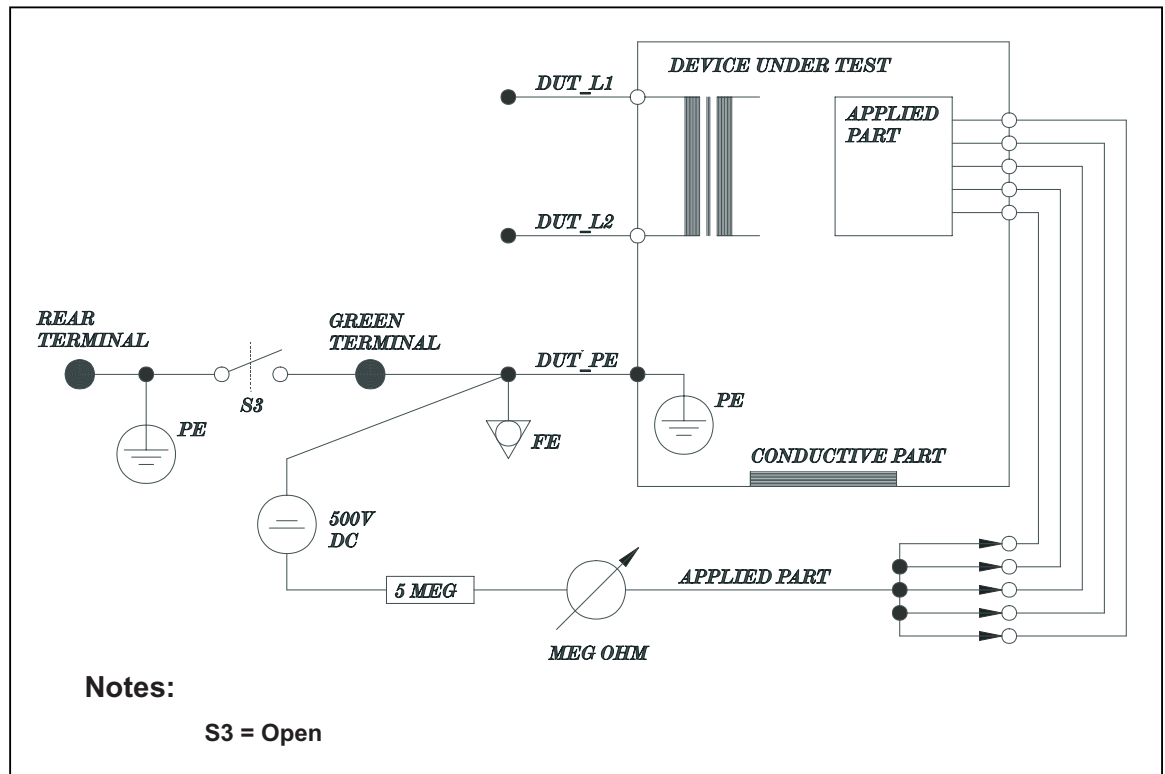

baw141f.eps

<b>Function:</b>	Measures insulation resistance (at 500 VDC) between all applied part connections and the DUT PE.
<b>Applicable to:</b>	IEC 601-1, Class I HEI 95, Class I

**Test Principle: Mains on Applied Part**

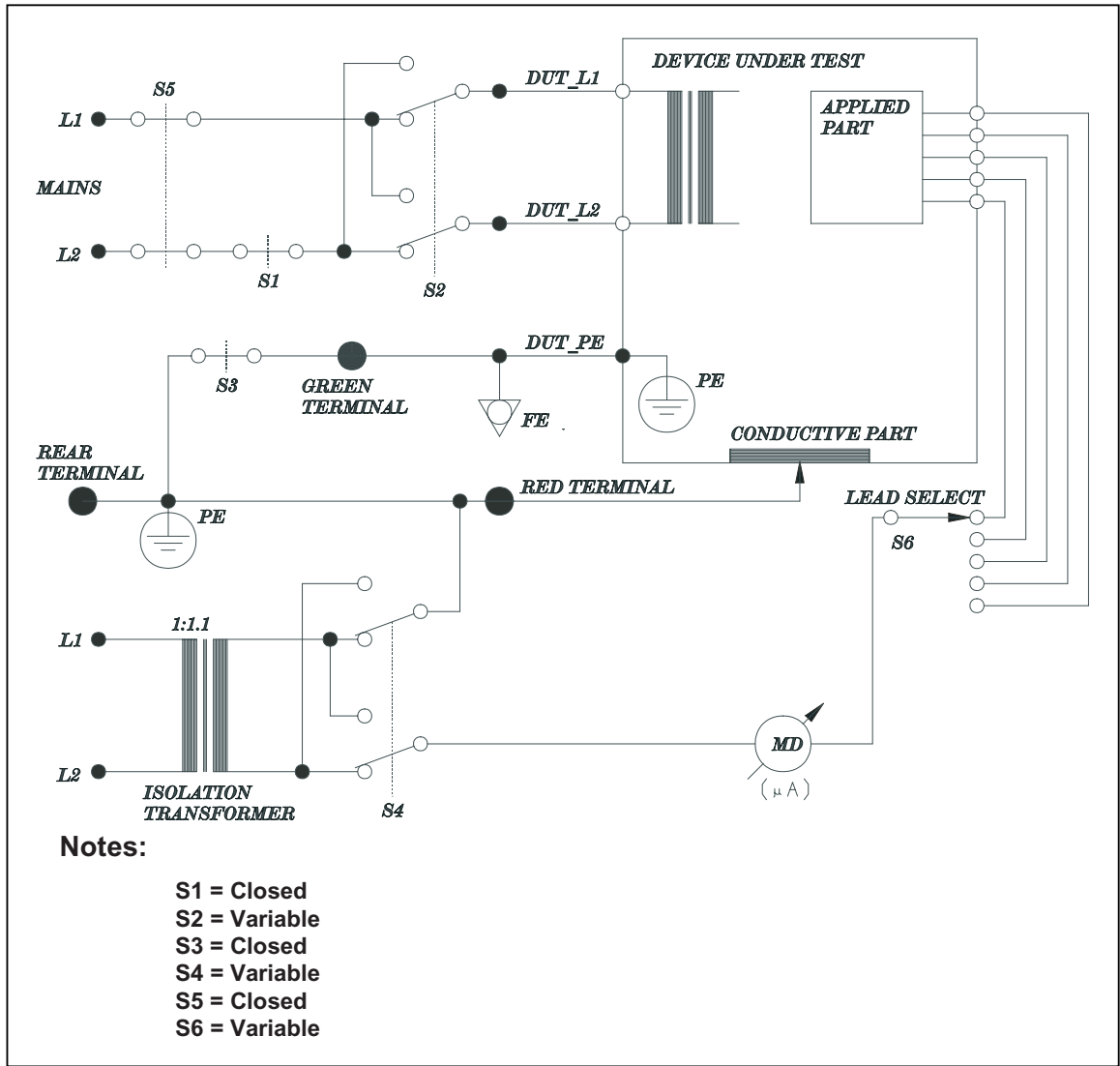

baw142f.eps

<b>Function:</b>	Measures the current that flows in response to an isolated AC voltage applied between selected applied parts and earth (and any conductive part connected to the RED terminal). The magnitude of the voltage is at least 110% of the mains voltage. The test is performed with normal and reverse mains supply polarity using S2, and normal and reverse isolated voltage supply polarity using S4.
<b>Applicable to:</b>	IEC 601-1 AAMI AS/NZS 3551

**Test Principle: Patient Auxiliary Current**

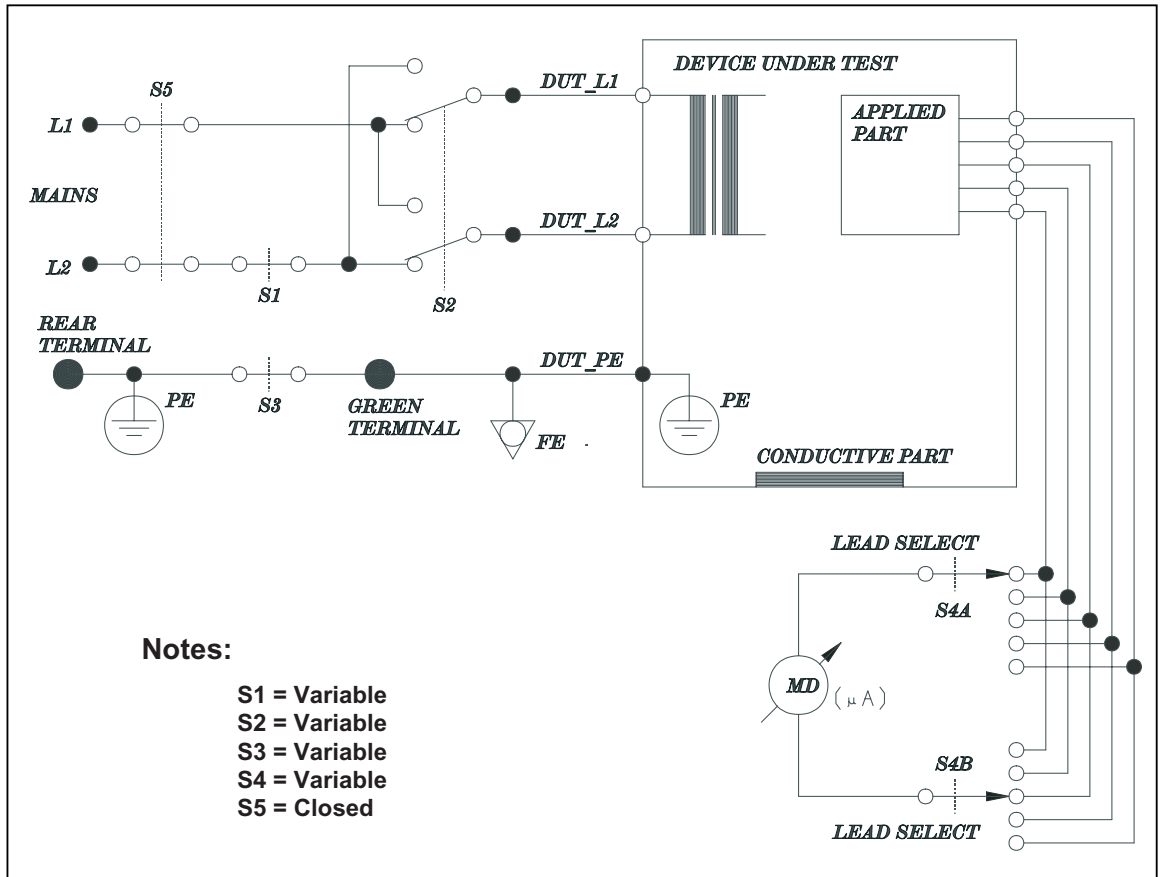

baw143f.eps

<b>Function:</b>	Measures the current between a selected applied part and all others. The test is performed with normal and reverse mains supply polarity using S2 and single fault conditions using S1 and S3.
<b>Applicable to:</b>	IEC 601-1 HEI 95 AAMI

**Test Principle: Patient Leakage Current**

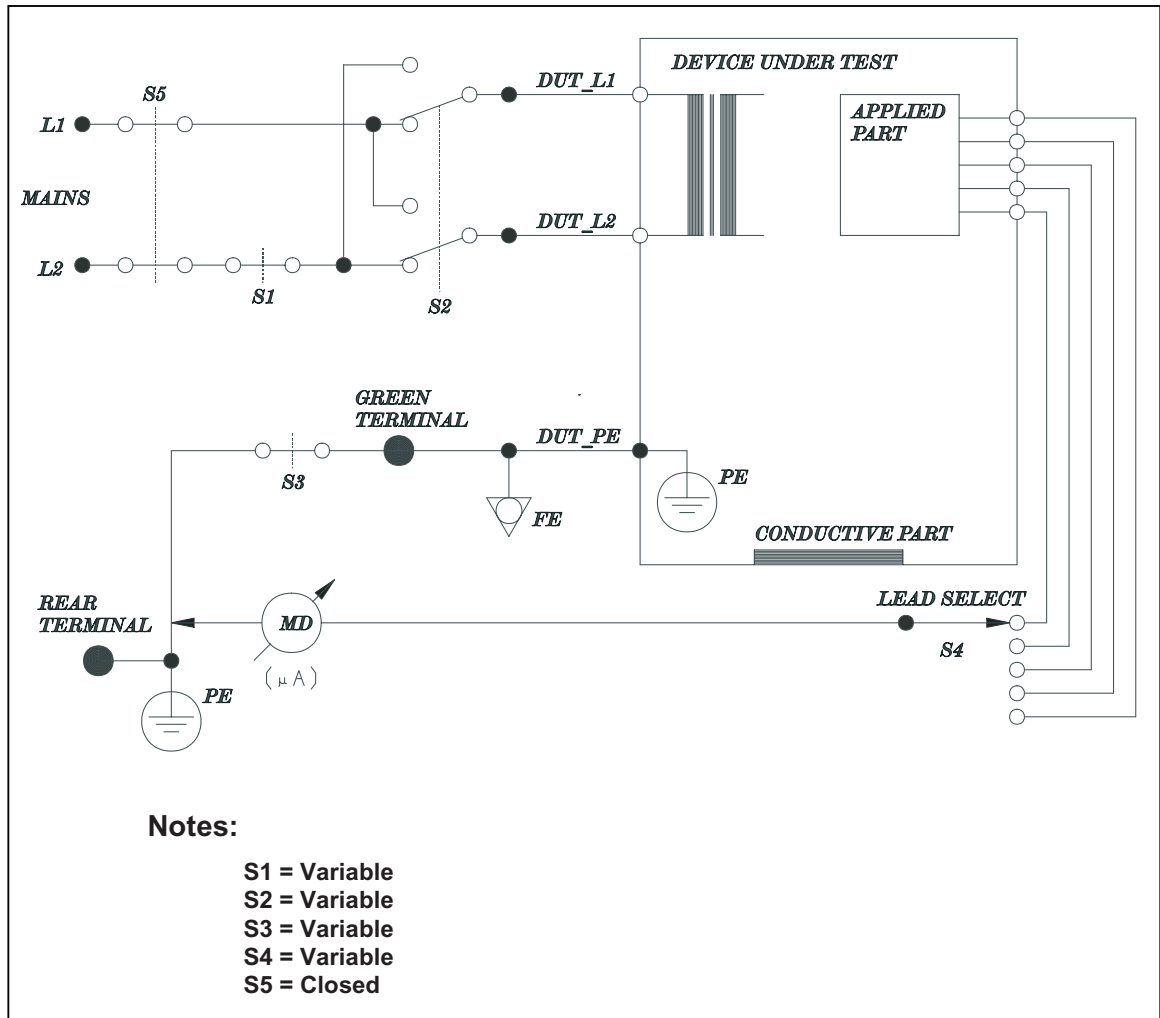

**Function:** Measures the current flowing between a selected applied part and the mains PE. The test is performed with normal and reverse mains supply polarity using S2 and single fault conditions using S3 and S1.

**Applicable to:** IEC 601-1  
 AAMI  
 HEI 95  
 AS/NZS 3551

### Test Principle: VDE, Equivalent Device Leakage

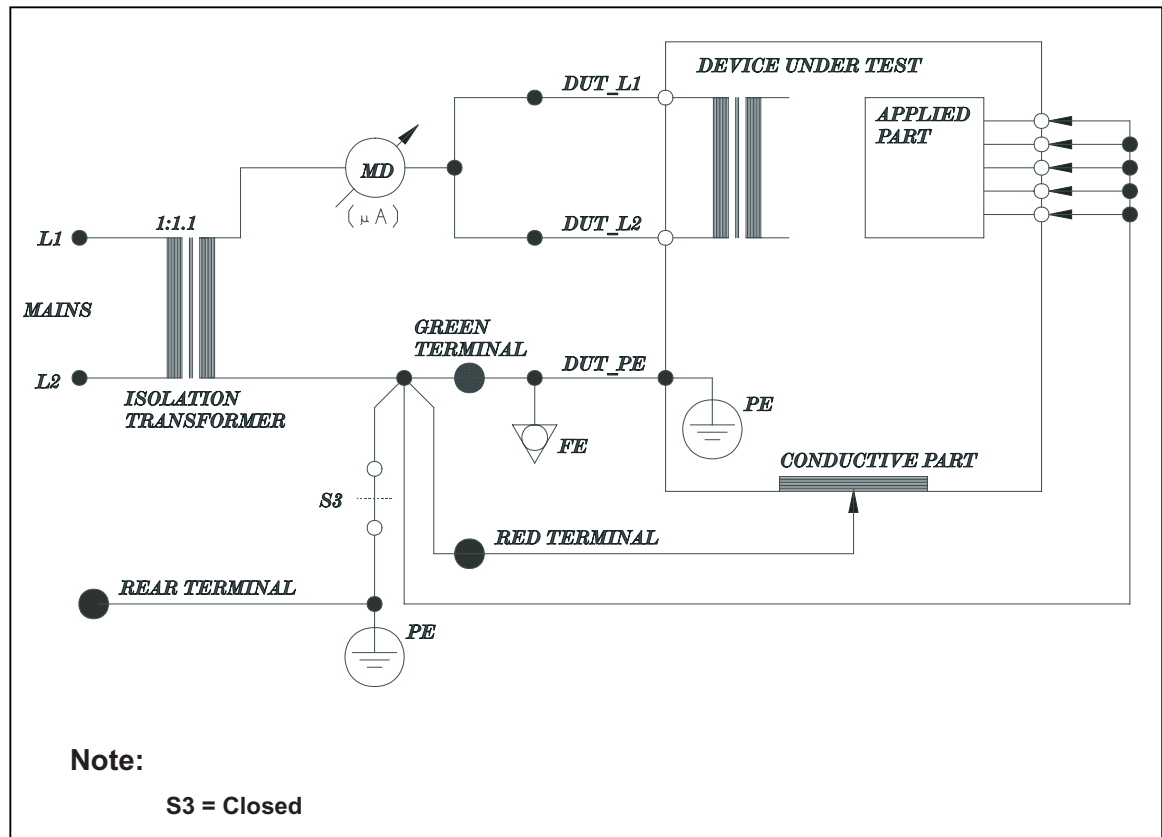

baw145f.eps

<b>Function:</b>	Measures the current that flows between the mains terminals of the DUT to the PE, applied parts, and exposed conductive parts of the DUT in response to an isolated AC voltage source with a magnitude of at least 110% of mains voltage.
<b>Applicable to:</b>	VDE 751.1 VDE 701

**Test Principle: VDE, Equivalent Patient Leakage**

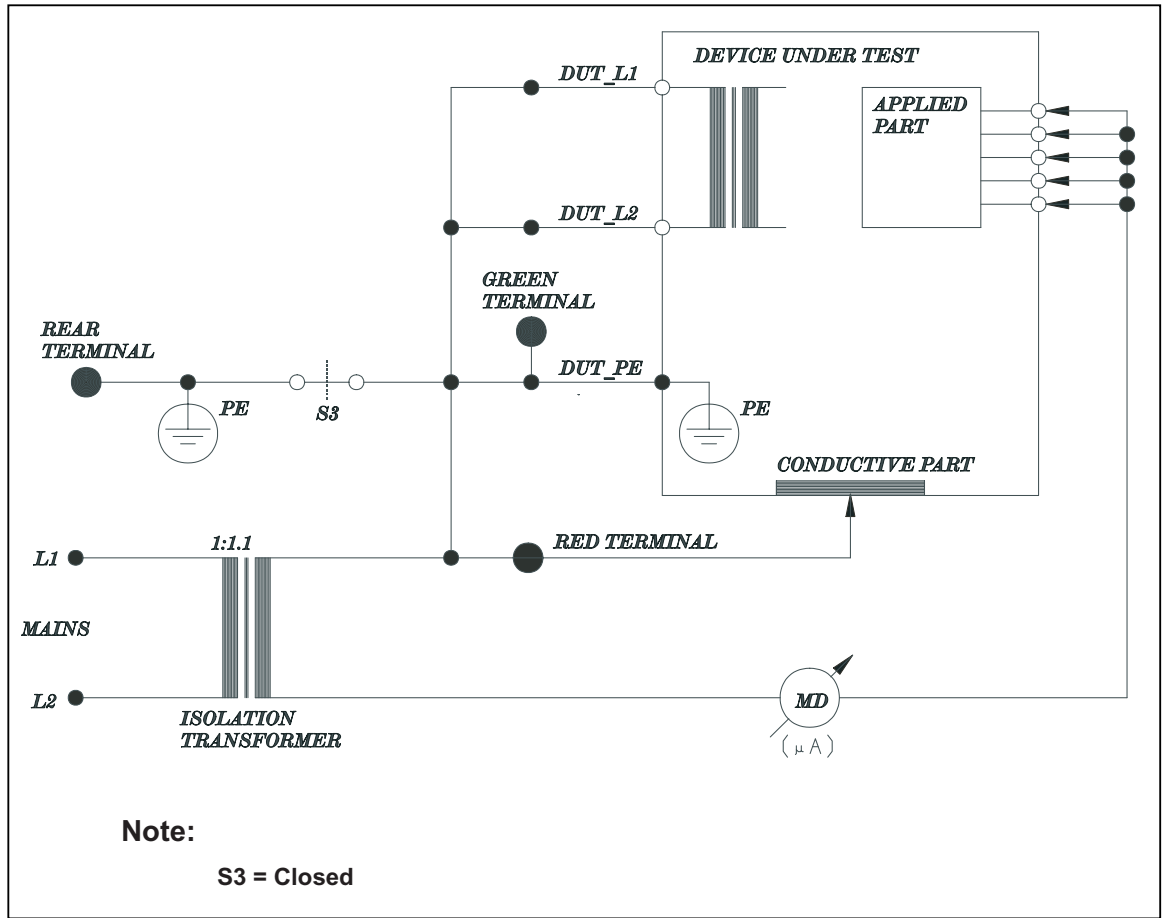

baw146f.eps

<b>Function:</b>	Measures the current that flows between the applied part terminals of the DUT to the PE, mains supply conductors L1 and L2, and exposed conductive parts of the DUT in response to an isolated AC voltage source with a magnitude of at least 110% of mains voltage.
<b>Applicable to:</b>	VDE 751.1

## Test Principle: Accessible Voltage

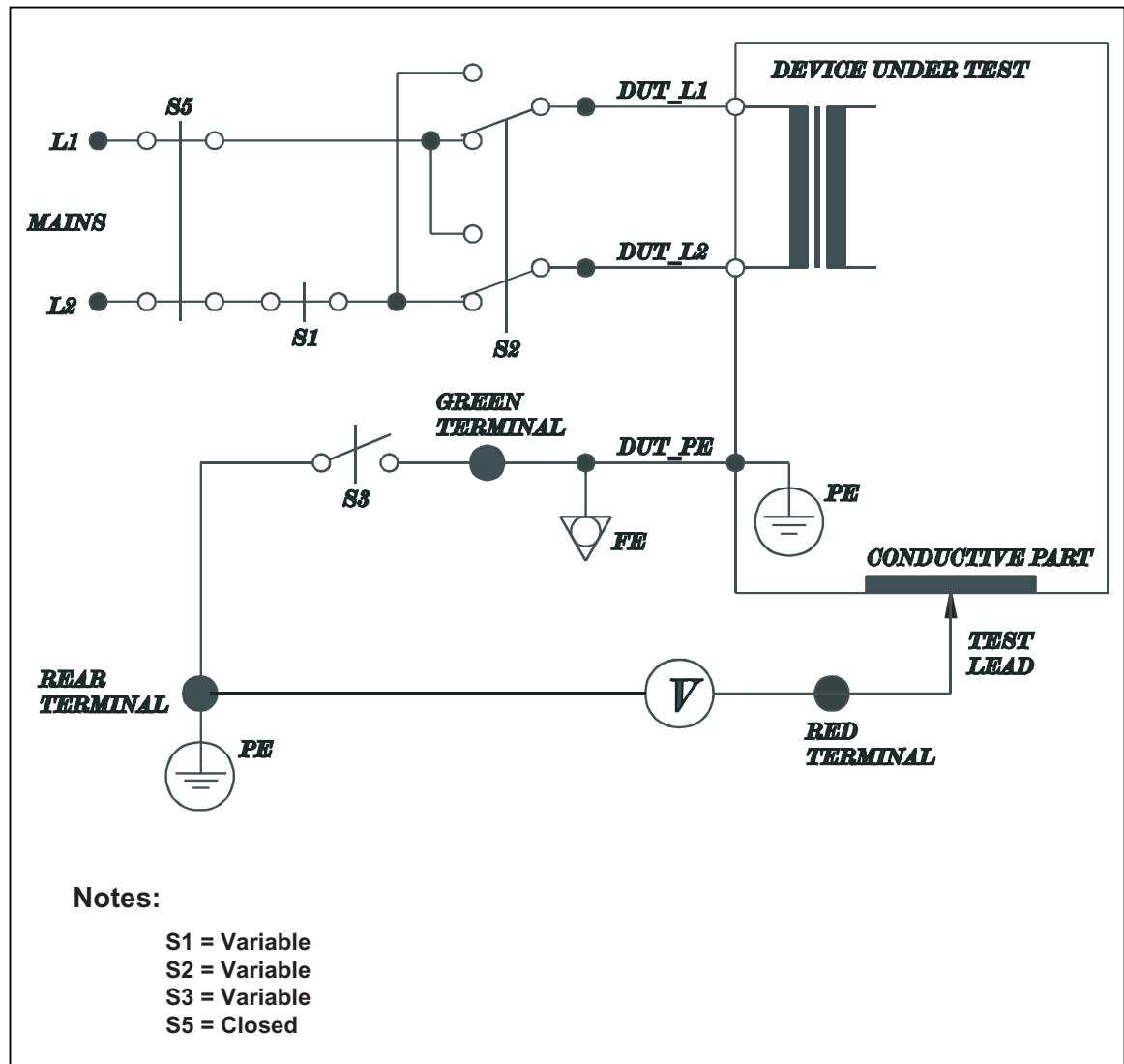

baw147f.eps

**Function:** Measures the voltage present on accessible parts relative to mains PE. The test is repeated with normal and reversed mains polarity and single faults of no earth and no L2.

**Applicable to:** IEC 1010

**Test Principle: Accessible Leakage Current**

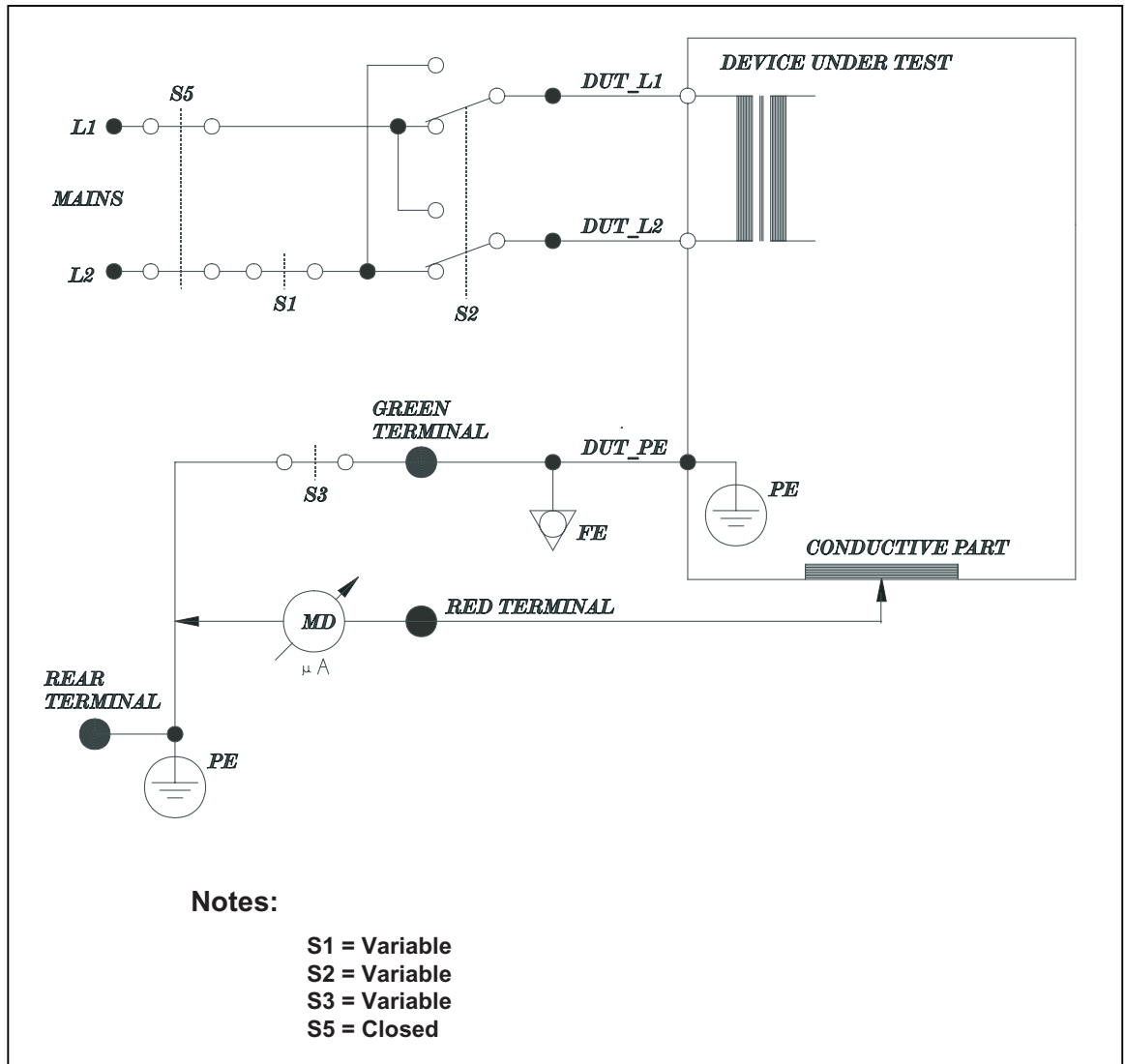

baw148f.eps

**Function:** Measures the current flowing from the RED TERMINAL to MAINS PE. Test is performed with normal and reverse mains supply polarity using S2, single fault condition open L2 using S1, and open earth using S3.

**Applicable to:** IEC 1010 (Accessible Leakage)

# Custom Standards

Chapter

9

This chapter describes how to define and edit custom test standards.

Although the 601PRO has many preprogrammed test standards, the operator can also define a custom test standard by selecting from among the 55 tests the 601PRO supports. The operator can edit any of the four custom standards by following the steps outlined below.

- 1. Defining/Editing a Custom Standard
- 2. Tests Available in a Custom Standard
- 3. Custom Standard Controlled Power Sequence

## 1. Defining/Editing a Custom Standard

- From the 601PRO **MAIN MENU**, press **UTILITIES**:

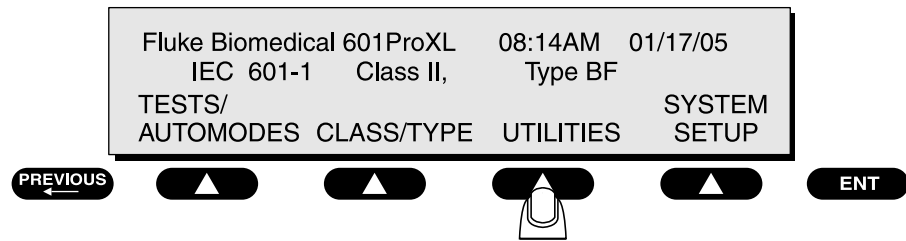

baw136f.eps

- Press **\*MORE** at the **SYSTEM TEST** menu to access **EDIT CUSTOM STANDARD**:

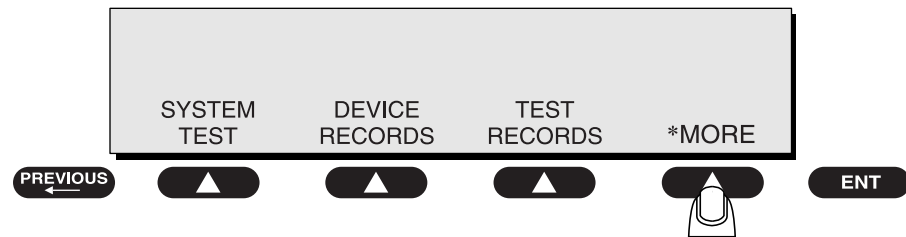

baw114f.eps

- Press **EDIT CUSTOM STANDARD**:

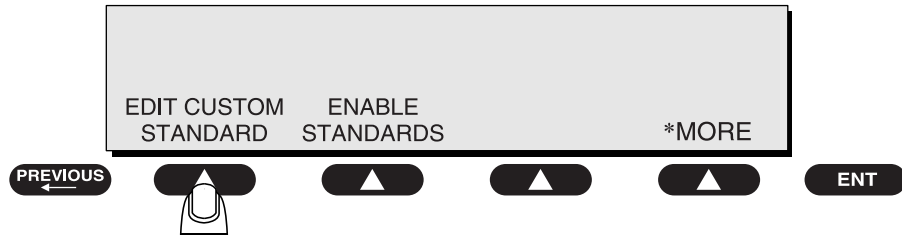

- At the **Select Custom Test Standard** screen, choose one of four available test standards to customize: baw115f.eps

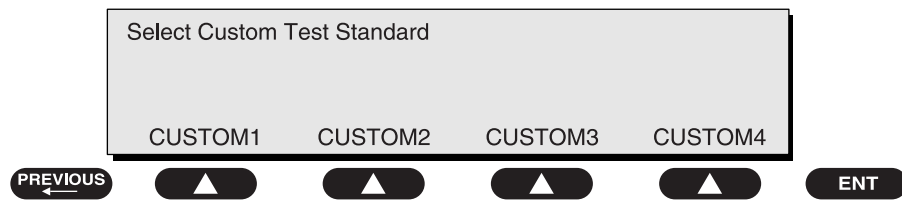

- There are three different Test Loads available on the 601PRO. Choose a Test Load and press **enter**: baw116f.eps

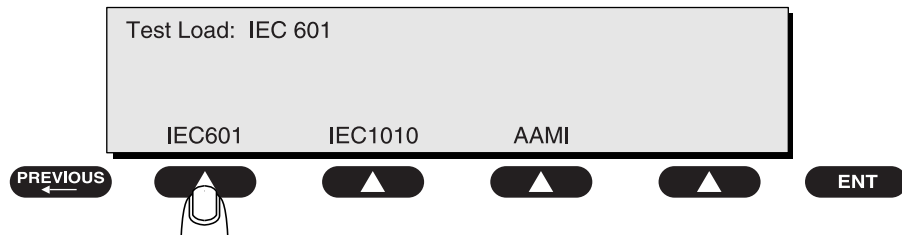

- The operator will now be prompted through a sequence of all tests available in the Custom Standard. Press **YES** to enable, or **NO** to disable the test. If the enabled test has no limit to enter, the following screen would be displayed: baw117f.eps

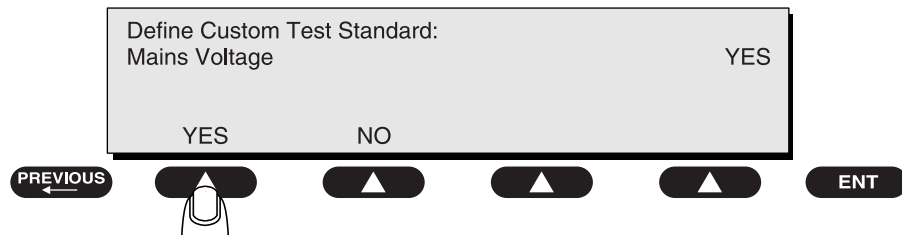

baw118f.eps

- If the test does require limits to be entered, press **YES**, and then use the numeric keys to enter the limit. The following typical screen would be displayed:

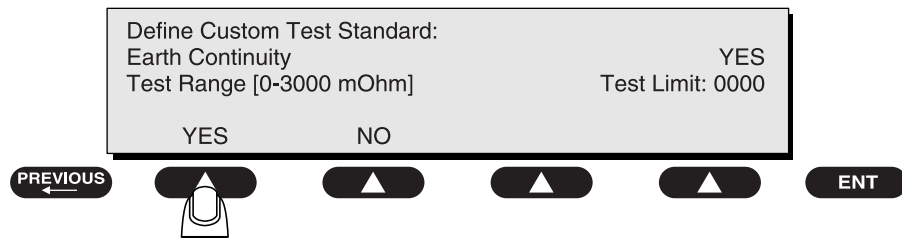

baw119f.eps

- Press **enter** to save the selection and advance to the next test standard.

☛ **Note:** Once the final selection is made, the 601PRO will automatically return to the **SYSTEM TEST** menu. Press **previous** to return to the **MAIN MENU**.

## 2. Tests Available in a Custom Standard

The following table lists all of the tests available in a custom standard, in the order in which the operator will be prompted. It also indicates whether the test requires limits.

### *Custom Test Standard Prompt Order*

SCREEN #	TEST	TEST LIMIT RANGE
1	Mains Voltage	NO LIMIT
2	Earth Resistance	0-3000 mOhm
3	Insul. Res: L1-L2-CASE	0-400 Mohm
4	Insul. Res: AP-CASE	0-400 Mohm
5	Current Consumption	NO LIMIT
6	Earth Leakage: Normal	0-8000 µA
7	Earth Leakage: No L2	0-8000 µA
8	Earth Leakage: Rev	0-8000 µA
9	Earth Leakage: Rev, No L2	0-8000 µA
10	Enclosure Leakage: Normal	0-8000 µA
11	Enclosure Leakage DC: Normal	0-8000 µA
12	Enclosure Leakage: No L2	0-8000 µA
13	Enclosure Leakage DC: No L2	0-8000 µA
14	Enclosure Leakage: No Earth	0-8000 µA
15	Enclosure Leakage DC: No Earth	0-8000 µA
16	Enclosure Leakage: Rev	0-8000 µA
17	Enclosure Leakage DC: Rev	0-8000 µA
18	Enclosure Leakage: Rev, No L2	0-8000 µA
19	Enclosure Leakage DC: Rev, No L2	0-8000 µA
20	Enclosure Leakage: Rev, No Earth	0-8000 µA
21	Enclosure Leakage DC: Rev, No Earth	0-8000 µA
22	Equiv Device Leakage	0-8000 µA
23	Patient Leakage: Normal	0-8000 µA
24	Patient Leakage DC: Normal	0-8000 µA
25	Patient Leakage: No L2	0-8000 µA
26	Patient Leakage DC: No L2	0-8000 µA
27	Patient Leakage: No Earth	0-8000 µA
28	Patient Leakage DC: No Earth	0-8000 µA
29	Patient Leakage: Rev	0-8000 µA
30	Patient Leakage DC: Rev	0-8000 µA
31	Patient Leakage: Rev, No L2	0-8000 µA
32	Patient Leakage DC: Rev, No L2	0-8000 µA
33	Patient Leakage: Rev, No Earth	0-8000 µA
34	Patient Leakage DC: Rev, No Earth	0-8000 µA
35	Mains On Applied Part: Normal	0-8000 µA
36	Mains On Applied Part: Rev	0-8000 µA
37	Patient Aux Current: Normal	0-8000 µA
38	Patient Aux Current DC: Normal	0-8000 µA
39	Patient Aux Current: No L2	0-8000 µA
40	Patient Aux Current DC: No L2	0-8000 µA
41	Patient Aux Current: No Earth	0-8000 µA
42	Patient Aux Current DC: No Earth	0-8000 µA
43	Patient Aux Current: Rev	0-8000 µA
44	Patient Aux Current DC: Rev	0-8000 µA
45	Patient Aux Current: Rev, No L2	0-8000 µA
46	Patient Aux Current DC: Rev, No L2	0-8000 µA
47	Patient Aux Current: Rev, No Earth	0-8000 µA
48	Patient Aux Current DC: Rev, No Earth	0-8000 µA
49	Equiv Patient Leakage	0-8000 µA
50	Accessible Voltage: Normal	0-300 V
51	Accessible Voltage: No Earth	0-300 V
52	Accessible Voltage: No L2	0-300 V
53	Accessible Voltage: Rev	0-300 V
54	Accessible Voltage: Rev, No Earth	0-300 V
55	Accessible Voltage: Rev, No L2	0-300 V

### 3. Custom Standard Controlled Power Sequence

The following table shows the controlled power sequence for custom test standards. Startup and Power-off delays are performed, regardless of the tests enabled. Only the tests enabled in the Custom Standard are performed. This sequence would be performed in both **Auto** and **Step** modes.

IEC-601-1 STANDARD	DUT OUTLET	
Description	Polarity	Circuit
Line Voltage V	N/A	OFF
Protective Earth Resistance $\Omega$	N/A	OFF
Insulation Resistance L1-L2-Case $\Omega$	N/A	OFF
Insulation Resistance All-Case M $\Omega$	N/A	OFF
Startup Delay (auto only)	Norm	Norm
Current in L2 - A	Norm	Norm
Accessible Voltage V	Norm	Norm
Enclosure Leakage - $\mu$ A	Norm	Norm
Accessible Leakage - $\mu$ A DC	Norm	Norm
Patient Leakage Current - $\mu$ A	Norm	Norm
Patient Leakage Current - $\mu$ A - DC Only	Norm	Norm
Mains on AP - $\mu$ A	Norm	Norm
Patient Auxiliary - $\mu$ A	Norm	Norm
Patient Auxiliary - $\mu$ A - DC Only	Norm	Norm
Accessible Voltage V	Norm	No E
Earth Leakage - $\mu$ A	Norm	No E
Enclosure Leakage - $\mu$ A	Norm	No E
Accessible Leakage - $\mu$ A DC	Norm	No E
Patient Leakage Current - $\mu$ A	Norm	No E
Patient Leakage Current - $\mu$ A - DC Only	Norm	No E
Patient Auxiliary - $\mu$ A	Norm	No E
Patient Auxiliary - $\mu$ A - DC Only	Norm	No E
Power OFF Delay	Norm	OFF
Startup Delay	Norm	No L2
Accessible Voltage V	Norm	No L2
Earth Leakage - $\mu$ A	Norm	No L2
Enclosure Leakage - $\mu$ A	Norm	No L2
Accessible Leakage - $\mu$ A DC	Norm	No L2
Patient Leakage Current - $\mu$ A	Norm	No L2
Patient Leakage Current - $\mu$ A - DC Only	Norm	No L2
Patient Auxiliary - $\mu$ A	Norm	No L2
Patient Auxiliary - $\mu$ A - DC Only	Norm	No L2

---

**Custom Standard Controlled Sequence (Cont.)**

IEC-601-1 STANDARD	DUT OUTLET	
Power OFF Delay	Reverse	OFF
Startup Delay	Reverse	Norm
Accessible Voltage V	Reverse	Norm
Earth Leakage -- $\mu$ A	Reverse	Norm
Enclosure Leakage -- $\mu$ A	Reverse	Norm
Accessible Leakage -- $\mu$ A DC	Reverse	Norm
Patient Leakage Current -- $\mu$ A	Reverse	Norm
Patient Leakage Current -- $\mu$ A - DC Only	Reverse	Norm
Patient Auxiliary - $\mu$ A	Reverse	Norm
Patient Auxiliary - $\mu$ A - DC Only	Reverse	Norm
Mains on AP – $\mu$ A	Reverse	Norm
Accessible Voltage V	Reverse	No E
Enclosure Leakage - $\mu$ A	Reverse	No E
Accessible Leakage - $\mu$ A DC	Reverse	No E
Patient Leakage Current - $\mu$ A	Reverse	No E
Patient Leakage Current - $\mu$ A - DC Only	Reverse	No E
Patient Auxiliary - $\mu$ A	Reverse	No E
Patient Auxiliary - $\mu$ A – DC Only	Reverse	No E
Power OFF Delay	Reverse	OFF
Startup Delay	Reverse	No L2
Accessible Voltage V	Reverse	No L2
Earth Leakage - $\mu$ A	Reverse	No L2
Enclosure Leakage - $\mu$ A	Reverse	No L2
Accessible Leakage - $\mu$ A DC	Reverse	No L2
Patient Leakage Current - $\mu$ A	Reverse	No L2
Patient Leakage Current - $\mu$ A - DC Only	Reverse	No L2
Patient Auxiliary - $\mu$ A	Reverse	No L2
Patient Auxiliary – $\mu$ A - DC Only	Reverse	No L2
Equivalent Device Leakage	N/A	OFF
Equivalent Patient Leakage	N/A	OFF

**Custom Standard Controlled Sequence (Cont.)**

IEC-601-1 STANDARD	DUT OUTLET	
	Polarity	Circuit
Description		
Line Voltage V	N/A	OFF
Protective Earth Resistance $\Omega$	N/A	OFF
Insulation Resistance L1-L2-Case $\Omega$	N/A	OFF
Insulation Resistance All-Case M $\Omega$	N/A	OFF
Startup Delay (auto only)	Norm	Norm
Current in L2 - A	Norm	Norm
Accessible Voltage V	Norm	Norm
Enclosure Leakage - $\mu$ A	Norm	Norm
Accessible Leakage - $\mu$ A DC	Norm	Norm
Patient Leakage Current - $\mu$ A	Norm	Norm
Patient Leakage Current - $\mu$ A - DC Only	Norm	Norm
Mains on AP - $\mu$ A	Norm	Norm
Patient Auxiliary - $\mu$ A	Norm	Norm
Patient Auxiliary - $\mu$ A - DC Only	Norm	Norm
Accessible Voltage V	Norm	No E
Earth Leakage - $\mu$ A	Norm	No E
Enclosure Leakage - $\mu$ A	Norm	No E
Accessible Leakage - $\mu$ A DC	Norm	No E
Patient Leakage Current - $\mu$ A	Norm	No E
Patient Leakage Current - $\mu$ A - DC Only	Norm	No E
Patient Auxiliary - $\mu$ A	Norm	No E
Patient Auxiliary - $\mu$ A - DC Only	Norm	No E
Power OFF Delay	Norm	OFF
Startup Delay	Norm	No L2
Accessible Voltage V	Norm	No L2
Earth Leakage - $\mu$ A	Norm	No L2
Enclosure Leakage - $\mu$ A	Norm	No L2
Accessible Leakage - $\mu$ A DC	Norm	No L2
Patient Leakage Current - $\mu$ A	Norm	No L2
Patient Leakage Current - $\mu$ A - DC Only	Norm	No L2
Patient Auxiliary - $\mu$ A	Norm	No L2
Patient Auxiliary - $\mu$ A - DC Only	Norm	No L2

---

**Custom Standard Control Sequence (Cont.)**

IEC-601-1 STANDARD	DUT OUTLET	
Power OFF Delay	Reverse	OFF
Startup Delay	Reverse	Norm
Accessible Voltage V	Reverse	Norm
Earth Leakage -- $\mu$ A	Reverse	Norm
Enclosure Leakage -- $\mu$ A	Reverse	Norm
Accessible Leakage -- $\mu$ A DC	Reverse	Norm
Patient Leakage Current -- $\mu$ A	Reverse	Norm
Patient Leakage Current -- $\mu$ A - DC Only	Reverse	Norm
Patient Auxiliary - $\mu$ A	Reverse	Norm
Patient Auxiliary - $\mu$ A - DC Only	Reverse	Norm
Mains on AP – $\mu$ A	Reverse	Norm
Accessible Voltage V	Reverse	No E
Enclosure Leakage - $\mu$ A	Reverse	No E
Accessible Leakage - $\mu$ A DC	Reverse	No E
Patient Leakage Current - $\mu$ A	Reverse	No E
Patient Leakage Current - $\mu$ A - DC Only	Reverse	No E
Patient Auxiliary - $\mu$ A	Reverse	No E
Patient Auxiliary - $\mu$ A – DC Only	Reverse	No E
Power OFF Delay	Reverse	OFF
Startup Delay	Reverse	No L2
Accessible Voltage V	Reverse	No L2
Earth Leakage - $\mu$ A	Reverse	No L2
Enclosure Leakage - $\mu$ A	Reverse	No L2
Accessible Leakage - $\mu$ A DC	Reverse	No L2
Patient Leakage Current - $\mu$ A	Reverse	No L2
Patient Leakage Current - $\mu$ A - DC Only	Reverse	No L2
Patient Auxiliary - $\mu$ A	Reverse	No L2
Patient Auxiliary – $\mu$ A - DC Only	Reverse	No L2
Equivalent Device Leakage	N/A	OFF
Equivalent Patient Leakage	N/A	OFF

---

# Computer Control

## Chapter

# 10

The 601PRO can be remotely operated using a host computer. The operator runs all tests normally accessible from the 601PRO's top panel by sending the appropriate command from the computer to the safety analyzer. The 601PRO then sends the test results or measurements back to the host computer.

The 601PRO is linked to the host computer using a standard D9M-D9F serial cable. One end of the serial cable is connected to the 601PRO's bi-directional RS232 port. The other end is connected to the computer's serial port. Commands are then sent from the host computer to activate top panel functions on the 601PRO.

---

## Setup Requirements

- ❑ Communications software, such as *ProComm™*, *CrossTalk™*, *Kermit™*, *Carbon Copy™* or Fluke Biomedical's *OTIS™* must be loaded on the host computer.
- ❑ The host computer and the 601PRO both must be set to the same communications parameters (for example, 2400 Baud, No Parity, 8 Data Bits, and 1 Stop Bit).
  - Set up communication parameters for the 601PRO by pressing **SYSTEM SETUP** then **RS232** key at the **MAIN MENU**. Select the appropriate Baud Rate. The other communications parameters are fixed at 1 Stop Bit, 8 Data Bits, and No Parity.
  - Set up communication parameters for the host computer following instructions provided with the installed communications software.
- ❑ A 9-pin male to 9-pin female D-type connector (available from Fluke Biomedical or an electronics supply outlet) must be attached to the computer and the 601PRO.



All command characters are sent in CAPITAL LETTERS (lower-case letters will not be recognized).

When a valid command is received by the 601PRO, computer control is established and the 601PRO displays the following screen:

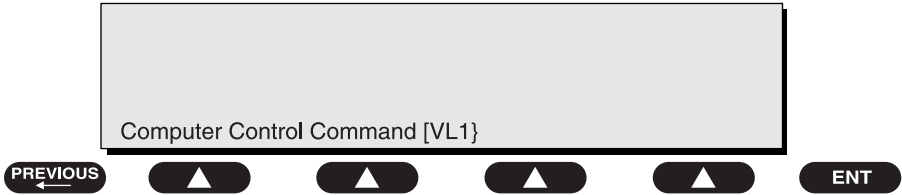

baw120f.eps

After the Mains Voltage test is completed, for example, the 601PRO would display the following screen:

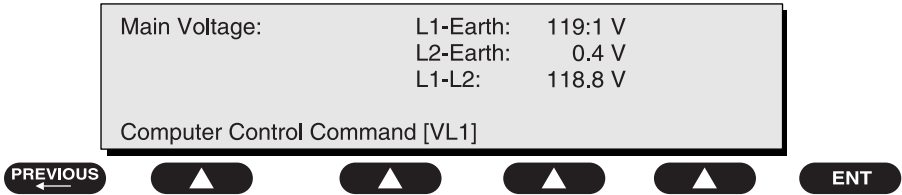

baw121f.eps

---

**Computer Control Commands**

<b>ENTER DESCRIPTION</b>		
<b>COMMAND</b>	<b>DESCRIPTION</b>	<b>NOTES</b>
[QUI]	Quit COM session	Bi-Directional
[Q]	Quit COM session	Bi-Directional
[RET]	Return Result of Last Test	
[R]	Return Result of Last Test	
[ACS]	Abort COM Session	Bi-Directional
[VER]	Version of 601PRO	
[SN]	Serial Number	
[FVER]	Returns Functionality Version	
[PRT]	Print last test result to printer	
[PRI]	Print Header to current printer	
[PRE]	Print Header to current printer	

<b>Calibration Check Commands</b>		
<b>COMMAND</b>	<b>DESCRIPTION</b>	<b>NOTES</b>
[CHK]	Calibration Check	
Returns "PASS*" or "FAIL*" for each test's RESISTANCE, LEAKAGE; i.e., "PASS*FAIL*" indicates RESIST passed, LEAKAGE failed.		

<b>Outlet Control Commands</b>		
<b>COMMAND</b>	<b>DESCRIPTION</b>	<b>NOTES</b>
[RPL]	Reverse Polarity	Turns DUT outlet ON
[NPL]	Normal Polarity	Turns DUT outlet ON
[CER]	Closed Earth	
[OER]	Open Earth	
[CL2]	Closed L2	
[OL2]	Open L2	
[OFF]	DUT Outlet OFF	
[ON]	DUT Outlet ON	
The DUT [ON] command always sets the outlet to Normal Polarity, Closed L2, Closed Earth. Note: The DUT outlet polarity can be switched from Reverse Polarity to Normal Polarity with the [ON] command. To prevent transients, the outlet control relays turns the outlet off; then, after a short delay, it turns the outlet back on with new polarity.		

---

**Computer Control Commands (Cont.)**

<b>Voltage Measurement Commands</b>		
<b>COMMAND</b>	<b>DESCRIPTION</b>	<b>NOTES</b>
[VL1]	Voltage L1-EARTH	
[VL2]	Voltage L2-EARTH	
[V12]	Voltage L1-L2	

<b>DUAL Mode Measurements</b>		
<b>COMMAND</b>	<b>DESCRIPTION</b>	<b>NOTES</b>
[DLV]	Dual Lead Voltage	

<b>Current Measurement Commands</b>		
<b>COMMAND</b>	<b>DESCRIPTION</b>	<b>NOTES</b>
[CUR]	Current Consumption	

<b>Insulation Resistance Measurement Commands</b>		
<b>COMMAND</b>	<b>DESCRIPTION</b>	<b>NOTES</b>
[IMN]	Mains-Case	
[IAL]	ALL - Case	
[IRA]	RA - Case	
[IRL]	RL - Case	
[ILA]	LA - Case	
[ILL]	LL - Case	
[IV1]	V1-V6-Case	

<b>Protective Earth Resistance Measurement Commands</b>		
<b>COMMAND</b>	<b>DESCRIPTION</b>	<b>NOTES</b>
[PEC]	Protective Earth Resistance	
[CAL]	Calibration of PEC at selected current	
[S01]	Select 1 Amp	
[S10]	Select 10 Amp	
[S25]	Select 25 Amp	

**Computer Control Commands (Cont.)**

<b>Leakage Current Measurement Commands (OUTLET AUTOMATICALLY ON FOR TEST)</b>		
<b>COMMAND</b>	<b>DESCRIPTION</b>	<b>NOTES</b>
[ENC]	Enclosure No AP-GND	601 Test Load
[ENA]	Enclosure AP-GND	601 Test Load
[ERT]*	Earth No AP-GND	601 Test Load
[ERA]*	Earth AP-GND	601 Test Load
[DLL]	Dual Lead Leakage	
[DLLD]	Dual Lead Leakage DC	
[AERT]*	Ground Wire Current No AP-GND	AAMI Test Load
[AERA]*	Ground Wire Current AP-GND	AAMI Test Load
[AENC]	Chassis Source Current No AP-GND	AAMI Test Load
[AENA]	Chassis Source Current AP-GND	AAMI Test Load

\*Leaves earth connection open when executed.

<b>Patient Leakage Measurement Commands (OUTLET AUTOMATICALLY ON FOR TEST)</b>		
<b>COMMAND</b>	<b>DESCRIPTION</b>	<b>NOTES</b>
[PAL]	Pat. Leakage ALL-EARTH	601 Test Load
[PRA]	Pat. Leakage RA-EARTH	601 Test Load
[PRL]	Pat. Leakage RL-EARTH	601 Test Load
[PLA]	Pat. Leakage LA-EARTH	601 Test Load
[PLL]	Pat. Leakage LL-EARTH	601 Test Load
[PV1]	Pat. Leakage V1-V6-EARTH	601 Test Load
[APAL]	Patient Source Current ALL-GND	AAMI Test Load
[APRA]	Patient Source Current RA-GND	AAMI Test Load
[APRL]	Patient Source Current RL-GND	AAMI Test Load
[APLA]	Patient Source Current LA-GND	AAMI Test Load
[APLL]	Patient Source Current LL-GND	AAMI Test Load
[APV1]	Patient Source Current V1-V6-GND	AAMI Test Load

---

**Computer Control Commands (Cont.)**

<b>Auxiliary Current Measurement Commands (OUTLET AUTOMATICALLY ON FOR TEST)</b>		
<b>COMMAND</b>	<b>DESCRIPTION</b>	<b>NOTES</b>
[ARA]	Aux. Leakage RA-ALL	601 Test Load
[ARL]	Aux. Leakage RL-ALL	601 Test Load
[ALA]	Aux. Leakage LA-ALL	601 Test Load
[ALL]	Aux. Leakage LL-ALL	601 Test Load
[AV1]	Aux. Leakage V1-V6-ALL	601 Test Load
[AARA]	Interlead Source Current RA-ALL	AAMI Test Load
[AARL]	Interlead Source Current RL-ALL	AAMI Test Load
[AALA]	Interlead Source Current LA-ALL	AAMI Test Load
[AALL]	Interlead Source Current LL-ALL	AAMI Test Load
[AAV1]	Interlead Source Current V1-V6-ALL	AAMI Test Load

<b>Mains on Applied Part Commands*</b>		
<b>COMMAND</b>	<b>DESCRIPTION</b>	<b>NOTES</b>
[MAL]	Mains ALL-EARTH	601 Test Load
[MRA]	Mains RA-EARTH	601 Test Load
[MRL]	Mains RL-EARTH	601 Test Load
[MLA]	Mains LA-EARTH	601 Test Load
[MLL]	Mains LL-EARTH	601 Test Load
[MV1]	Mains V1-V6-EARTH	601 Test Load
[MCL]	Mains on AP CAL	601 Test Load
[RAL]	Rev Mains ALL-EARTH	601 Test Load
[RRA]	Rev Mains RA-EARTH	601 Test Load
[RRL]	Rev Mains RL-EARTH	601 Test Load
[RLA]	Rev Mains LA-EARTH	601 Test Load
[RLL]	Rev Mains LL-EARTH	601 Test Load
[RV1]	Rev Mains V1-V6-EARTH	601 Test Load

\*Forces L2 closed to perform test.

---

**Computer Control Commands (Cont.)**

<b>Mains on Applied Part Commands (Cont.*</b>		
[AMAL]	Sink Current ALL-GND	AAMI Test Load
[AMRA]	Sink Current RA-GND	AAMI Test Load
[AMRL]	Sink Current RL-GND	AAMI Test Load
[AMLA]	Sink Current LA-GND	AAMI Test Load
[AMLL]	Sink Current LL-GND	AAMI Test Load
[AMV1]	Sink Current V1-V6-ALL-GND	AAMI Test Load
[ARAL]	Rev Sink Current ALL-GND	AAMI Test Load
[ARRA]	Rev Sink Current RA-GND	AAMI Test Load
[ARRL]	Rev Sink Current RL-GND	AAMI Test Load
[ARLA]	Rev Sink Current LA-GND	AAMI Test Load
[ARLL]	Rev Sink Current LL-GND	AAMI Test Load
[ARV1]	Rev Sink Current V1-V6-GND	AAMI Test Load

\*Forces L2 closed to perform test.

---

**Computer Control Commands (Cont.)**

<b>Patient Leakage Measurement – DC-Only Commands (OUTLET AUTOMATICALLY ON FOR TEST)</b>		
<b>COMMAND</b>	<b>DESCRIPTION</b>	<b>NOTES</b>
[PALD]	Pat. Leakage ALL-EARTH	601 Test Load
[PRAD]	Pat. Leakage RA-EARTH	601 Test Load
[PRLD]	Pat. Leakage RL-EARTH	601 Test Load
[PLAD]	Pat. Leakage LA-EARTH	601 Test Load
[PLLD]	Pat. Leakage LL-EARTH	601 Test Load
[PV1D]	Pat. Leakage V1-V6-EARTH	601 Test Load

<b>Auxiliary Current Measurement – DC-Only Commands (OUTLET AUTOMATICALLY ON FOR TEST)</b>		
<b>COMMAND</b>	<b>DESCRIPTION</b>	<b>NOTES</b>
[ARAD]	Aux. Leakage RA-ALL	601 Test Load
[ARLD]	Aux. Leakage RL-ALL	601 Test Load
[ALAD]	Aux. Leakage LA-ALL	601 Test Load
[ALLD]	Aux. Leakage LL-ALL	601 Test Load
[AV1D]	Aux. Leakage V1-V6-ALL	601 Test Load

<b>IEC 1010 Tests (OUTLET AUTOMATICALLY ON FOR TEST)</b>		
<b>COMMAND</b>	<b>DESCRIPTION</b>	<b>NOTES</b>
[ACV]	Accessible Voltage	
[ACL]	Accessible Leakage RMS	IEC 1010 Test Load
[ACLD]	Accessible Leakage DC	IEC 1010 Test Load

<b>VDE Tests</b>		
<b>COMMAND</b>	<b>DESCRIPTION</b>	<b>NOTES</b>
[EDL]	Equivalent Device Leak	601 Test Load
[EPL]	Equivalent Patient Leakage RMS	601 Test Load
[EPLD]	Equivalent Patient Leakage DC	601 Test Load

---

**Computer Control Commands (Cont.)**

<b>ECG/Performance Wave Commands</b>		
<b>COMMAND</b>	<b>DESCRIPTION</b>	<b>NOTES</b>
[W01]	ECG 30	
[W02]	ECG 60	
[W03]	ECG 120	
[W04]	ECG 180	
[W05]	ECG 240	
[W06]	Pulse 30 BPM	
[W07]	Pulse 60 BPM	
[W08]	Square wave 0.125 Hz	
[W09]	Square wave 2 Hz	
[W010]	Sin 10	
[W011]	Sin 40	
[W012]	Sin 50	
[W013]	Sin 60	
[W014]	Sin 100	
[W015]	Triangle 2 Hz	
[W016]	AFIB	
[W017]	AFLUT	
[W018]	ATACH	
[W019]	PVC 1	
[W020]	RUN	
[W021]	R on T	
[W022]	IDIO	
[W023]	VTACH	
[W024]	VFIB	
[WSP]	Stop Waveform Output	

---

**Computer Control Commands (Cont.)**

<b>Computer Control Commands Supported for Compatibility to Older Models of the ISA601PROCE</b>	
<b>COMMAND</b>	<b>DESCRIPTION</b>
[GBS] Get Bar-code String	Returns an empty string "<CR><LF>"
[BAR] wand is not supported	Returns "NO" indicating the stand-alone barcode
[BAT] Battery Status	Returns "YES"
[KBO] Ext. Keyboard Option	Returns "YES"
[RAM] Amount of RAM Installed	Returns "512K"
[EER] Eprom Re-initialization	Returns "PASS"

601PRO SERIES<sub>XL</sub>

# Error Messages, Troubleshooting, and Support

## Chapter

# 11

The tables in this chapter list error messages that may be received during 601PRO operation, and a brief description of the action to take.

This chapter also contains information on contacting Fluke Biomedical's Technical Service Department for assistance and returning the 601PRO for repairs or upgrades.

- 1. Error Codes**
- 2. Errors and Suggested Corrective Actions**
- 3. Troubleshooting**
- 4. Service**

## 1. Error Codes

Errors that fall in the range of 0100-0900 and A100-AA00 should never be encountered. However, if they are, you should collect as much information as possible about what you were doing at the time of the error, determine if it is reproducible, and contact Fluke Biomedical or your local Service Center and report the problem.

Code	Description
0100	ABORT_ERR
0200	Class not valid for present standard.
0300	Type not valid for present standard and class.
0400	Standard not known.
0500	Measurement type requested invalid.
0600	No Result found for number specified.
0700	Invalid mains voltage state.
0800	Invalid applied part.
0900	Invalid test group for standard.
A100	Task control block not available.
A200	Cursor position requested invalid.
A300	<device> not available.
A400	Failed code checksum test on power up.
A600	Flash configuration timed out.
A700	Flash read didn't match write.
A800	Device Info Record not on page boundary.
A900	RESULT structure not on page boundary.
AA00	Language files do not match size.

## 2. Errors and Suggested Corrective Actions

Follow the suggested corrective action for errors in the range of 0A00-1900. If the error persists, you should collect as much information as possible about what you were doing at the time of the error, and contact Fluke Biomedical or your local Service Center to report the problem.

Code	Description	Corrective Action
0A00	System Test: 500-Volt failure.	Recycle power and try again.
0B00	System Test: Mains Voltage failure.	Recycle power and try again.
0C00	System Test: No Earth connection.	Try a different wall outlet (see note below).
0D00	System Test Failure preventing action.	The unit failed the power-up test(s). Recycle power and try again.
0E00	A to D read failure.	Internal hardware error. Contact Fluke Biomedical or your local Service Center to report the problem.
0F00	Calibration Value out of range.	Confirm that patient leads are disconnected. If the problem persists, contact Fluke Biomedical or your local Service Center to report the problem.
1000	I Scale failure during calibration.	Internal hardware error. Contact Fluke Biomedical or your local Service Center to report the problem.
1100	Voltage across 0.5 Ohm cal resistor error.	Internal hardware error. Contact Fluke Biomedical or your local Service Center to report the problem.
1200	Calibration Resistor current error.	Internal hardware error. Contact Fluke Biomedical or your local Service Center to report the problem.
1300	System test leakage error.	Internal hardware error. Contact Fluke Biomedical or your local Service Center to report the problem.
1400	DIR checksum error.	Contact Fluke Biomedical or your local Service Center to report the problem. The most probable cause is that Flash is worn out in that sector.
1500	Result checksum error.	Contact Fluke Biomedical or your local Service Center to report the problem. The most probable cause is that Flash is worn out in that sector.
1600	No Test. Results storage full. Delete old.	Delete some stored results to make room for new ones. Refer to <i>Chapter 5</i> .
1700	Printer timeout. Print buffer full.	You need to have a printer enabled and connected. Refer to <i>Chapter 2</i> .
1800	Device Record Format is invalid.	Review the format of the data being transmitted to the 601PRO. Refer to <i>Chapter 6</i> .
1900	Serial Port timeout. Cannot transmit.	Verify that you are using the correct serial cable, that it is properly connected, and that the communications parameters are correctly set-up on both the PC and the 601. Refer to <i>Chapter 6</i> .
2100	Cannot delete all Device information until all test results have been deleted.	Delete all test results. Refer to <i>Chapter 5</i> .

☛ **Note:** If a connection to **Mains Earth** is provided by means other than through the line cord earth conductor (such as through a serial port or parallel port ground connection), the 601PRO will **not** detect an Open Earth Error as part of the outlet test that occurs upon power-up.

### 3. Troubleshooting

If possible, please first visit the Fluke Biomedical Technical Assistance Center Web site at [www.flukebiomedical.com](http://www.flukebiomedical.com) where we post answers to frequently asked questions. Otherwise, call or e-mail for assistance.

### 4. Technical Assistance

Technical assistance can be obtained by contacting Fluke through one of the following contact methods:

E-mail:	<a href="mailto:techservices@flukebiomedical.com">techservices@flukebiomedical.com</a>
Domestic Phone:	800.648.7952
International Phone:	775.886.6321
Fax:	775.883.9541

### 5. Service

Before returning the 601PRO for factory service, contact Fluke's Service Department for further information.

E-mail:	<a href="mailto:servicestatus@fluke.com">servicestatus@fluke.com</a>
Phone:	888.993.5853
International customers contact Fluke at	<a href="mailto:service.international@fluke.com">service.international@fluke.com</a>
Internet:	<a href="http://www.flukebiomedical.com">www.flukebiomedical.com</a>

#### ***Shipping Requirements***

1. Pack the unit carefully. Before shipping, contact Fluke Service for a Return Materials Authorization (RMA) Number. Be sure to reference the RMA number on documentation inside the box and on the shipping label.
2. Insure the unit for full retail value and ship to:

Fluke Customer Service  
1420 – 75<sup>th</sup> Street SW  
Everett, WA 98203  
USA

601PRO SERIES<sub>XL</sub>

# Specifications

## Appendix

# A

This appendix details the device specifications for the 601PRO Safety Analyzer.

For more information, please contact your Fluke Biomedical Service representative.

### Environmental

Operating Temp:	10°C to 40° C (50°F to 104° F)
Storage Temp:	-20° to +50° C (-4°F to +122° F)
Humidity:	80% Non-Condensing
Operating Voltage Range for full performance:	90-132 V RMS 198-264 V RMS 47-63 Hz ≤ 15 A
Front Panel Receptacle:	15 Amps @ 120 V 15 Amps 1/2 HP Max @ 250 V

### True RMS

	IEC-601/AAMI	IEC-1010
Measurement Range:	0.0-8000 $\mu$ A True RMS (per IEC 601-1 filter)	0.0-16000 $\mu$ A True RMS**
Accuracy:	DC -1 kHz $\pm$ 1% of reading $\pm$ 1 $\mu$ A 1 kHz-100 kHz $\pm$ 2% of reading $\pm$ 1 $\mu$ A 100 kHz -1 MHz $\pm$ 5% of reading $\pm$ 1 $\mu$ A	DC -1 kHz $\pm$ 2% of reading $\pm$ 2 $\mu$ A 1 kHz -100 kHz $\pm$ 4% of reading $\pm$ 2 $\mu$ A 100 kHz -1 MHz $\pm$ 10% of reading $\pm$ 10 $\mu$ A
Input Impedance:	Per selected test load specification	Per IEC-1010 specification
Frequency Response:	DC and 25 Hz -1 MHz per selected test load specification*	DC and 25 Hz -1 MHz per selected test load specification*

\*Accuracy at frequencies below approximately 25 Hz (but not DC) is not specified (because of "ripple" effects).

\*\*For some leakage tests, the displayed range may be 0.0-9999 when using the IEC 1010 test load.

**DC Only**

	IEC-601/AAMI	IEC-1010
Measurement Range:	0-8,000 $\mu$ A	0-16,000 $\mu$ A*
Accuracy:	$\pm 1\%$ of reading $\pm 1\mu$ A (@ DC)	$\pm 2\%$ of reading $\pm 2\mu$ A (@ DC)
Input Impedance:	1000 $\Omega \pm 1\%$ (@ DC)	2000 $\Omega \pm 1\%$ (@ DC)
Cutoff Frequency:	5 Hz (approximate)	5 Hz (approximate)
50 Hz Rejection:	60 dB minimum	60 dB minimum

For the Equivalent Device, Equivalent Patient, and Mains on Applied Part Leakage Current tests, the following exceptions apply:

Accuracy:	$\pm 2\%$ of reading $\pm 6\mu$ A
Applied Voltage:	$\geq 110\%$ of mains

\*For some leakage tests, the displayed range may be 0.0-9999 when using the IEC 1010 test load.

**Voltage Measurements – Main, Single, and Dual Lead**

Configuration:	Single Lead: Red input jack to mains earth Mains: L1 to L2, L1 to E, L2 to E Dual Lead: Between red and black input jacks not referenced to earth ground
Measurement Range:	0.000-300.0 V true RMS
Accuracy:	DC -100 Hz $\pm 1.5\%$ of reading $\pm 1$ LSD
Input Impedance:	$\geq 0.5$ M $\Omega$

**Protective Earth Resistance**

The following conditions apply:

- Selectable test current for 1 A, 10 A, or 25 A with open circuit voltage less than 6 VAC RMS
- Open circuit resistance is defined as greater than 10  $\Omega$
- Single lead measurement is to be taken between the RED terminal and the receptacle FE terminal.

The selectable test current for 1A, 10A, or 25A with open circuit voltage is less than 6 VAC RMS, where open circuit resistance is defined as greater than 10 Ω. Single lead measurement is to be taken between the red terminal and the receptacle FE terminal.

Range:	0.000-2.999 Ω
Accuracy:	± 5 % of reading ± 4 mΩ [see (a), (b), (c), and (d) below]
Open Circuit Resistance:	≥ 10 Ω
Current Source Output:	<u>1 Amp selection</u> 0.85-1.15 Amps AC RMS (0.000-2.999 Ω)  <u>10 Amp selection</u> 9.50-10.50 Amps AC RMS (0.000-0.999 Ω) 2.00-10.50 Amps AC RMS (1.000-2.999 Ω)  <u>25 Amp selection</u> 22.5-25 Amps AC RMS (0.000-0.200 Ω) 15.0-25 Amps AC RMS (0.000-0.300 Ω) 2.0-25 Amps AC RMS (0.000-2.999 Ω)

- (a) Accuracy specification applies to measurements with 1 Amp and 25 Amp test current where the load inductance is less than 60 μH and the phase angle is less than 10 degrees. The Calibration resistance is required to be less than 35 mΩ (factory-supplied test leads in good condition).

Accuracy specification applies to measurements with 10 Amp test current where the load inductance is less than 30 μH and the phase angle is less than 10 degrees. The calibration resistance is required to be less than 35 mΩ (factory-supplied test leads in good condition).

- (b) Specified accuracy with 10 Amp test current for load inductance up to 60 μH and phase angle greater than 10 degrees:

5% of reading ± 20 mΩ (resistance range of 10-199 mΩ)

5% of reading ± 10 mΩ (resistance range of 200-2999 mΩ)

- (c) Specified accuracy for load inductance up to 120  $\mu\text{H}$  and phase angle greater than 10 degrees:

**1A and 25 A:**

5% of reading  $\pm$  30  $\text{m}\Omega$  (resistance range of 10-99  $\text{m}\Omega$ )

5% of reading  $\pm$  15  $\text{m}\Omega$  (resistance range of 100-2999  $\text{m}\Omega$ )

**10 A:**

5% of reading  $\pm$  50  $\text{m}\Omega$  (resistance range of 10-99  $\text{m}\Omega$ ) for 10 A

5% of reading  $\pm$  35  $\text{m}\Omega$  (resistance range of 100-2999  $\text{m}\Omega$ ) for 10 A

- (d) Specified accuracy for load inductance up to 420  $\mu\text{H}$  and phase angle greater than 10 degrees:

5% of reading  $\pm$  40  $\text{m}\Omega$  (1A setting, resistance range of 10-2999  $\text{m}\Omega$ )

10 A and 25 A measurements not specified above 120  $\mu\text{H}$

**Technical Notes:**

If the load inductance and phase angle of the load are unknown, performing the following test may approximate their magnitudes:

- Make resistance measurements at both 1A and 25A current levels and calculate the difference.
  - $\Rightarrow$  If this difference is greater than 5%  $\pm$  4  $\text{m}\Omega$  of the 1 A reading, the inductance and phase angle of the load has exceeded 60  $\mu\text{H}$  and/or 10 degrees.
  - $\Rightarrow$  If the difference is 5%  $\pm$  35  $\text{m}\Omega$  of the 1 A reading, the inductance and phase angle has exceeded 120  $\mu\text{H}$  and/or 10 degrees.
  - $\Rightarrow$  Finally, if the difference is greater than 5%  $\pm$  150  $\text{m}\Omega$  of the 1 A reading, the inductance and phase angle of the load has exceeded 420  $\mu\text{H}$  and/or 10 degrees.

This test is based on the observation that as the load inductance exceeds 60  $\mu\text{H}$  or the load phase angle exceeds 10 degrees, the 1 A and 25 A measurements increasingly differ in value.

---

**Insulation Resistance**

Configuration:	Measurement taken through the DUT outlet as well as the Patient leads
Applied Voltage:	500 V $\pm$ 10% through a 5 M $\Omega$ limiting resistor
Accuracy:	$\pm$ 5% of reading $\pm$ 2 LSD
Measurement Range:	0.5-400.0 M $\Omega$

---

**Current Consumption**

Configuration:	DUT outlet can be configured as Open or Closed Earth and L2 and Reverse/Normal polarity
Range:	0.0-15.0 Amps AC true RMS
Accuracy:	$\pm$ 5% of reading $\pm$ 2 LSD

---

**ECG Simulation and Performance Testing**

Accuracy:	$\pm$ 2% of reading for rate or $\pm$ 5% of reading for Amplitude, which is fixed at 1 mV peak on a LEAD II ECG connection (except for triangle wave, which is 2 mV peak to peak)
Square wave:	0.125, 2 Hz 50% duty cycle
Sine wave:	10, 40, 50, 60, 100 Hz
Triangle wave:	2 Hz, 2 mV
ECG complex:	30, 60, 120, 180, 240 BPM
Pulse:	30,60 BPM 63 ms pulse width 600-700 $\mu$ s rise and fall time
Other waveforms:	A-Fib, A-Flutter, A-Tach, Idioventricular, PVC1, R-on-T, Run, V-Fib, V-Tach

---

**Serial Port**

Baud Rate: 2400, 9600, 19,200  
 Databits: 8  
 Parity: None  
 Stop bits: 1  
 Signal levels: Per EIA/TIA-574  
 Direction: DCE  
 Software flow control: None  
 Hardware flow control: Bidirectional using RTS and CTS signals  
 Connector: DB9F

Serial Port Pinouts and Connections:

601PROseries <sub>XL</sub> (DCE)		connects to	COMPUTER (DTE)	
1	N/C	—————→	1	DCD(input)
2	RX	—————→	2	RX (input)
3	TX	←————	3	TX (output)
4	N/C	←————	4	DTR (output)
5	GND	←————→	5	GND
6	DSR (fixed on)	—————→	6	DSR (input)
7	RTS	←————	7	RTS (output)
8	CTS	—————→	8	CTS (input)
9	N/C	—————→	9	RI (input)

The following are used when transmitting device records from to unit to unit:

601PROseries <sub>XL</sub> (DCE)		connects to	601PROseries <sub>XL</sub> (DCE)	
1	N/C	—————	1	NC
2	RX	←————→	2	RX
3	TX	←————→	3	TX
4	N/C	—————	4	NC
5	GND	—————	5	GND
6	DSR	—————	6	DSR
7	RTS	←————→	7	RTS
8	CTS	←————→	8	CTS
9	N/C	—————	9	NC

---

**Printer Port**

Parallel printer port. No graphics.

---

# Keyboard Options/Barcode Keyboard Wedge

## Appendix

# B

An optional keyboard is available for the 601PRO that allow the user complete control of the unit. The external keyboard can control manual tests, setup, utilities and input into text fields for comments, technician name, device information and more.

In addition, wedge-type barcode scanners can be used with the 601PRO to efficiently scan barcode labels and place the text as input to Control Number requests and other device information.

The 601PRO's keyboard interface is embedded for use with IBM PC AT-style keyboards. The circular 5-pin DIN connector is located on the back of the 601PRO.

☛ **Note:** Power off the 601PRO before connecting a keyboard or barcode keyboard wedge.

---

## Supported Keyboards

The supported standard U.S. keyboard and the recommended French, German, and Italian keyboards are shown on pages B-4 and B-5. The keyboard characters that the 601PRO displays and prints are 0..9, A..Z, and period, hyphen open parenthesis, close parenthesis, exclamation, question, slash, semicolon, and colon. Lower case a..z are all converted to upper case. The Escape, Enter, 0..9, slash, hyphen, and F1 through F8 keys are mapped to the 601PRO's front panel keypad. Ctrl, Alt, Alt Gr, Scroll Lock, and Num Lock have no effect.

Fluke Biomedical recommends the following keyboards, which are manufactured by Cherry Electrical ([www.cherrycorp.com](http://www.cherrycorp.com)):

Language	Manufacturing Part No.
French	G84-4100PPAFR
German	G84-4100PPADE
Italian	G84-4100PPAIT
English	G84-4100PPAUS

The English keyboard is available from Fluke Biomedical as Part Number 2213184.

The following table provides the translation of the External keyboard function keys to the onboard keypad:

External Keyboard Key	601PRO Behavior
F1	Previous
F2-F5	Menu/Soft Keys 1-4
F6	Print Header
F7	Print Data
F8	View Settings
Enter	Enter
Esc	Esc/Stop

The Fluke Biomedical-specified keyboards do not have a separate numeric keypad but have a second function (Fn) key that makes the Num Lock appear to always be active. Although not labeled on the Fluke Biomedical-specified keyboards, the following keys are mapped to the characters shown.

- **Note:** The function keys for the divide operation and decimal separator, and the Del key, do not produce the correct or desired character in all language versions.

Key Legend	Result	Key Legend	Result
Pg Up	9	End	1
Up Arrow	8	Ins	0
Home	7	Fn – Divide	'/'
Right Arrow	6	Fn – Multiply	No action
Left Arrow	4	Fn – Minus	'-'
Pg Dn	3	Fn – Plus	No action
Down Arrow	2	Del	No action
		Fn – Decimal Sep	'.'

---

### What Is a Barcode Keyboard Wedge?

A barcode keyboard wedge is a device that decodes the signals produced by a barcode scanner and generates keyboard codes from these signals. The 601PRO interprets the keyboard codes as data that was typed on an external keyboard.

Before using a barcode scanner with the 601PRO, follow the steps below to verify that it is connected properly.

- 1. Program the Barcode Scanner for Use With the 601PRO**
- 2. Attach the Barcode Keyboard Wedge**
- 3. Use the Barcode Scanner to Enter Information**

#### **1. Program the Barcode Scanner for Use With the 601PRO**

Follow the manufacturer's instructions for programming the barcode scanner.

## 2. Attach the Barcode Keyboard Wedge

1. Turn off power to the 601PRO.
2. Connect the barcode keyboard wedge to the keyboard port on the back of the 601PRO.
3. Plug the barcode scanner into the barcode keyboard wedge.
4. To use an external keyboard in conjunction with the barcode scanner, plug the keyboard into the open connector on the barcode keyboard wedge.

## 3. Use the Barcode Scanner to Enter Information

Use the barcode wand when prompted to enter information. For example, When prompted in **Auto** or **Manual** mode to enter a control number, swipe the wand over the barcode on the DUT.

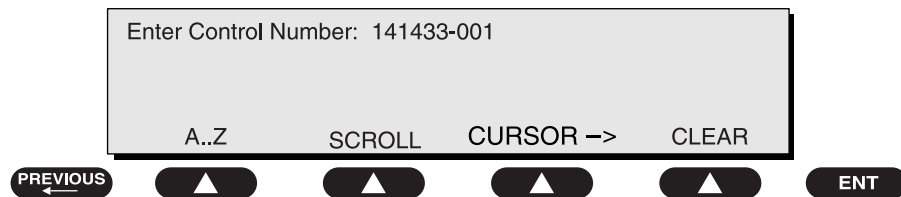

Once connected, any data, scanned or typed, will appear to the 601PRO as if it had been typed on the keyboard. baw122f.eps

- ☛ **Note:** Some scanners may require configuration before use. Refer to the manufacturer's instructions.

**French Keyboard**

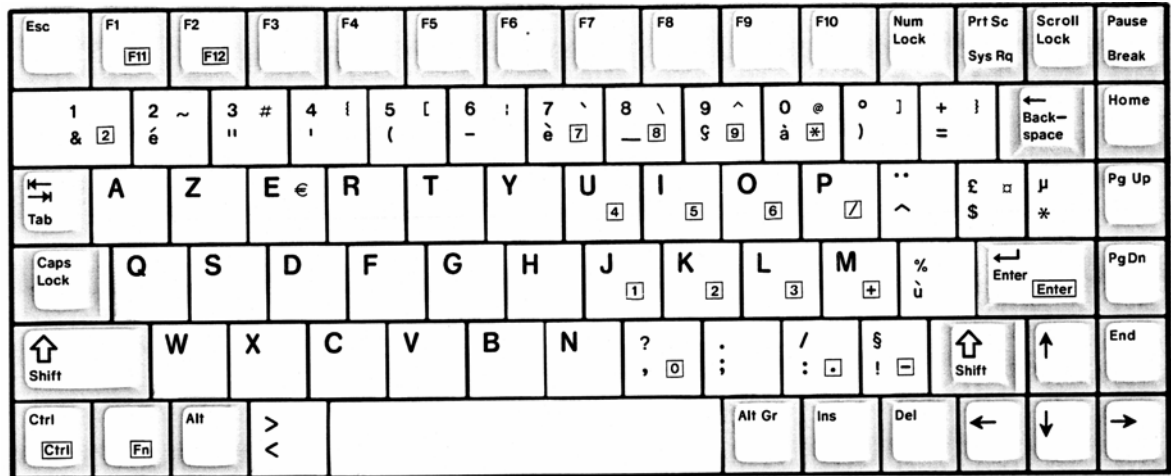

**German Keyboard**

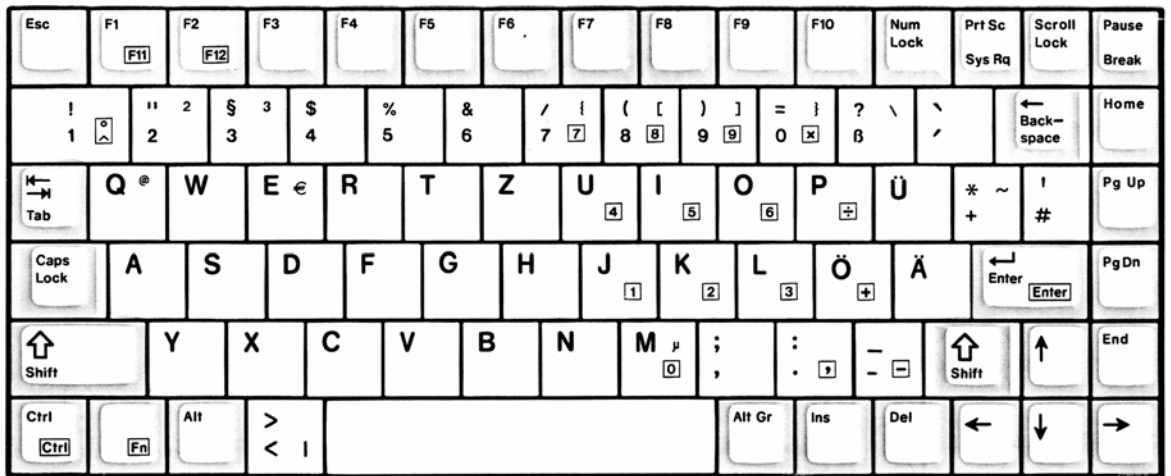

*Italian Keyboard*

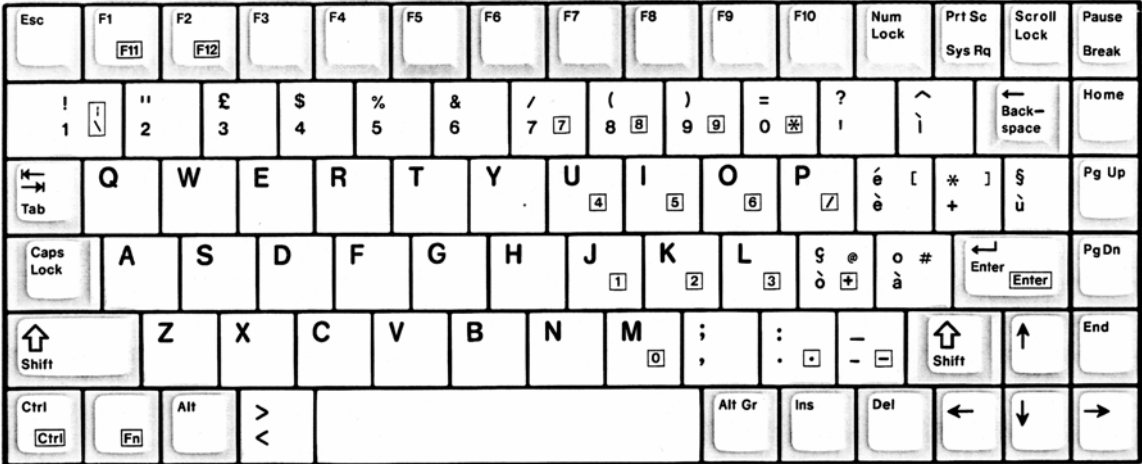

*English Keyboard*

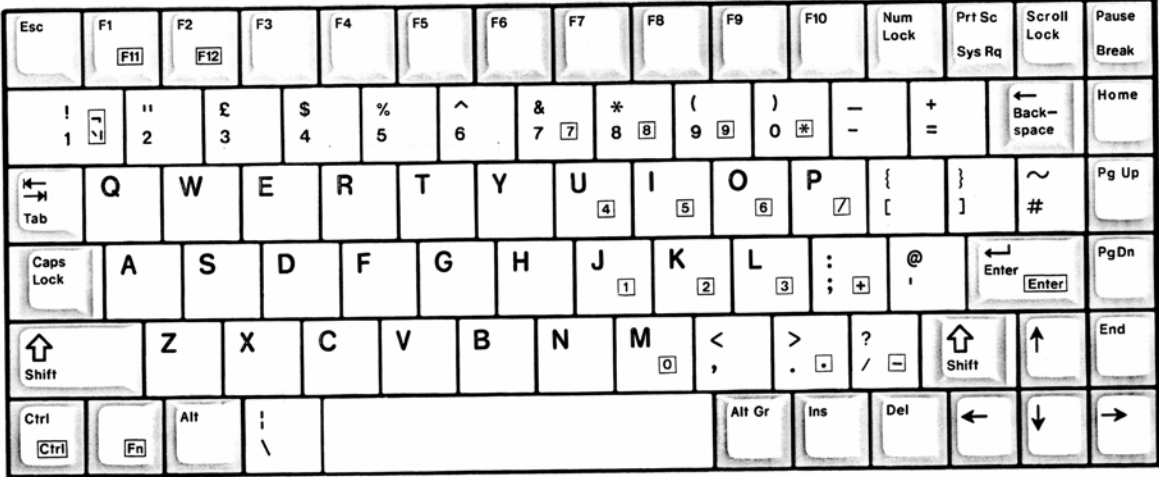

601PRO SERIES<sub>XL</sub>

---

# Printer Maintenance

## Appendix

# C

The 601PRO printer requires a minimum amount of maintenance. Beyond paper replacement and keeping the printer free of dirt, the printer should provide years of trouble-free operation.

- 1. Identifying the Installed Printer**
- 2. Martell Thermal Printer**
- 3. Seiko Thermal Printer**
- 4. Cleaning the Printer**

### **Identifying the Installed Printer**

The 601PRO has had more than one type of printer installed over its lifetime. Initially, the 601PRO was manufactured with a Seiko Thermal Printer installed. More recently however, a Martell Thermal printer has replaced the Seiko model to provide you with improved performance.

Before proceeding with the maintenance steps below, it's important to identify the type of printer installed in the 601PRO analyzer. The Martell printer is easily identified by its black colored chassis. The Seiko printer on the other hand, has a beige chassis. For the proper maintenance steps for the printer installed, locate the section in the following text appropriate for the identified printer. It is also important to obtain the correct printer paper roll by using the part number appropriate to the identified printer found in the *Accessories* section in chapter 1.

### **Martell Thermal Printer (black chassis)**

To gain access to the printer, press the cover release and swing the printer cover away from the printer housing.

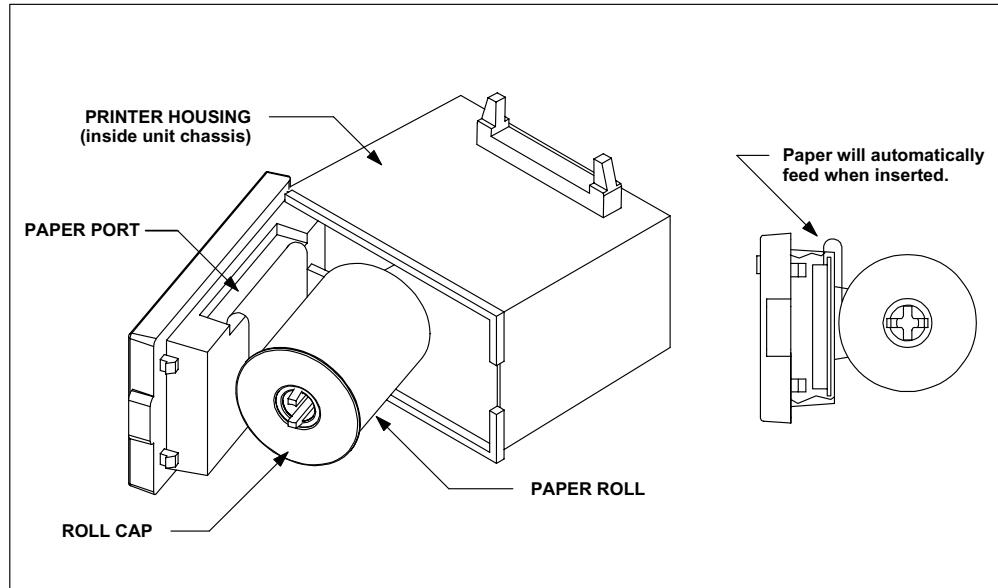

baw157f.eps

### Replacing the paper roll

1. Remove the roll cap by squeezing the barbs at the end of the paper roll shaft.
2. Load a new roll (PN 2248743) oriented as shown in the figure above.
3. Feed a clean, straight edge from the roll into the entry port of the printer mechanism. The paper will be sensed automatically and feed into the front slot for printing.
4. Wind any excess paper onto the roll and replace the roll cap.
5. Close the printer cover.

### Printer Self-Test

1. Turn off the power to the 601Pro analyzer.
2. Press and hold the paper feed button on the printer cover.
3. Turn the power back on.
4. Release the paper feed button.

### Seiko Thermal Printer (beige chassis)

Before proceeding, turn off the power to the 601PRO analyzer.

To gain access to the printer, gently press the latch buttons on the sides of the front panel and remove the panel.

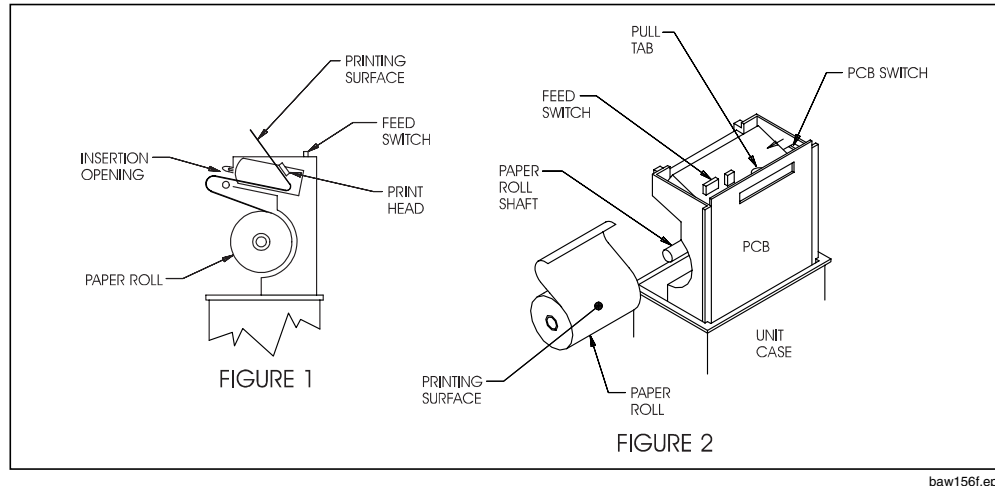

baw156f.eps

### Replacing the Paper Roll

1. Using the red pull-tab on the printed circuit board (PCB), carefully pull the printer from its internal cradle, until you feel some resistance (*Figure 1*).
2. Slide the old roll of paper off its shaft.
3. Place the new paper roll (PN 2248719) on the shaft as illustrated in *Figure 2*.

Note: The outside surface of the paper roll is the printing surface.

4. Gently push the paper into the paper feed opening (*Figure 1*).
5. Power up the unit.
6. Press the feed switch until the paper emerges from the print head. If the rollers do not automatically move the paper forward, apply light pressure on the paper to manually feed it into the rollers.
7. Carefully place the printer back in the 601PRO case.
8. Advance enough paper so that paper appears outside the output opening on the front panel.
9. Make sure the printed circuit board switch is positioned toward the pull-tab (*Figure 2*).
10. Replace the front panel of the unit, ensuring that the latches engage.
11. Test the functionality by printing

### Cleaning the Printer

- Clean the top panel using a dampened cloth and mild detergent.
- No cleaning of the internal components is required.

601PRO SERIES<sub>XL</sub>

# Test Data Record ASCII Character Formats

## Appendix

# D

Test data records must only contain ASCII characters formatted as shown in the table below. The first portion of the record contains information about the test setup, time, and date, etc., and each of these fields is surrounded by quotation marks. The remainder of the information pertains to test results: All lines are delimited with <CR><LF>. The data fields are delimited by commas as shown. The "P/F/N" relates to the Pass/Failure or test NOT performed. The individual safety tests are represented by numbers in the first field of each line and are described in parenthesis. Fields left blank at the time of test will appear as <CR><LF> (a blank line)

FIELD	DESCRIPTION
601PRO Serial Number	15 characters max
Month of test	"XX" two digit month
Day of test	"XX" two digit day
Year of test	"XX" two digit year
Hour of test	"XX" two digit (24 hour clock)
Minute of test	"XX" two digit
Technician	15 characters max
Control Number	15 characters max
Procedure ID	20 characters max
Serial Number of DUT	16 characters max
Location	30 characters max
Device Type	20 characters max
Manufacturer	25 characters max
Class of test	"I", "II", "IP", "??"
Type of test	"B", "BF", "CF", "T", "L", "??"
Test Standard	"IEC601-1", "IEC1010", "VDE751-1", "VDE701", "AAMI", "AS/NZS 3551", "CUSTOM1", "CUSTOM2", "CUSTOM3" and "CUSTOM4"
Test Current	"1", "10", or "25" Amperes
Leads	"X" ( 0,1,2,3, 4 or 5 )
Lead Definition	"(RA-XX)(RL-XX)(LA-XX)(LL-XX)(V-XX)"
Power Off Delay	"0-9999"
Startup Delay	"0-9999"
"100", "data"	(Voltage L1-Earth)
"101", "data"	(Voltage L2-Earth)
"102", "data"	(Voltage L1-L2)
"150", "data", "P/F/N"	(Earth Resistance)
"200", "data", "P/F"	(Insulation Resistance)
"201", "data", "P/F"	(Insulation Resistance AP- All leads )
"205", "data", "P/F"	(Insulation Resistance AP-RA only)
"206", "data", "P/F"	(Insulation Resistance AP-RL only)
"207", "data", "P/F"	(Insulation Resistance AP-LA only)
"208", "data", "P/F"	(Insulation Resistance AP-LL only)
"209", "data", "P/F"	(Insulation Resistance AP-V1-V6 only)
"250", "data"	(Current Consumption)
"300", "data", "P/F/N"	(Earth Leakage Normal)
"301", "data", "P/F/N"	(Earth Leakage No L2)
"302", "data", "P/F/N"	(Earth Leakage Rev Pol)
"303", "data", "P/F/N"	(Earth Leakage Rev No L2)
"350", "data", "P/F/N"	(Enclosure Leak Normal)

Field	Description
"351","data","P/F/N"	(Enclosure Leak No L2)
"352","data","P/F/N"	(Enclosure Leak No Earth)
"353","data","P/F/N"	(Enclosure Leak Rev Pol)
"354","data","P/F/N"	(Enclosure Leak Rev No L2)
"355","data","P/F/N"	(Enclosure Leak Rev No Earth)
"360","data","P/F/N"	(VDE 751.1 & VDE 701 Equiv Device Leak)
"405","data","P/F/N"	(Patient Leak Normal -All Leads)
"406","data","P/F/N"	(Patient Leak Normal -RA)
"407","data","P/F/N"	(Patient Leak Normal -RL)
"408","data","P/F/N"	(Patient Leak Normal -LA)
"409","data","P/F/N"	(Patient Leak Normal -LL)
"410","data","P/F/N"	(Patient Leak Normal -V1-V6)
"415","data","P/F/N"	(Patient Leak No L2-All Leads)
"416","data","P/F/N"	(Patient Leak No L2-RA)
"417","data","P/F/N"	(Patient Leak No L2-RL)
"418","data","P/F/N"	(Patient Leak No L2-LA)
"419","data","P/F/N"	(Patient Leak No L2-LL)
"420","data","P/F/N"	(Patient Leak No L2-V1-V6)
"425","data","P/F/N"	(Patient Leak No Earth-All Leads)
"426","data","P/F/N"	(Patient Leak No Earth-RA)
"427","data","P/F/N"	(Patient Leak No Earth-RL)
"428","data","P/F/N"	(Patient Leak No Earth-LA)
"429","data","P/F/N"	(Patient Leak No Earth-LL)
"430","data","P/F/N"	(Patient Leak No Earth-V1-V6)
"435","data","P/F/N"	(Patient Leak Rev Pol-All Leads Earth)
"436","data","P/F/N"	(Patient Leak Rev Pol-RA to Earth)
"437","data","P/F/N"	(Patient Leak Rev Pol-RL to Earth)
"438","data","P/F/N"	(Patient Leak Rev Pol-LA to Earth)
"439","data","P/F/N"	(Patient Leak Rev Pol-LL to Earth)
"440","data","P/F/N"	(Patient Leak Rev Pol-V1-V6 Earth)
"445","data","P/F/N"	(Patient Leak Rev No L2- All Leads Earth)
"446","data","P/F/N"	(Patient Leak Rev No L2- RA to Earth)
"447","data","P/F/N"	(Patient Leak Rev No L2- RL to Earth)
"448","data","P/F/N"	(Patient Leak Rev No L2- LA to Earth)
"449","data","P/F/N"	(Patient Leak Rev No L2- LL to Earth)
"450","data","P/F/N"	(Patient Leak Rev No L2- V1-V6 to Earth)
"455","data","P/F/N"	(Patient Leak Rev No Earth-All Leads)
"456","data","P/F/N"	(Patient Leak Rev No Earth- RA)
"457","data","P/F/N"	(Patient Leak Rev No Earth- RL)
"458","data","P/F/N"	(Patient Leak Rev No Earth- LA)
"459","data","P/F/N"	(Patient Leak Rev No Earth- LL)
"460","data","P/F/N"	(Patient Leak Rev No Earth- V1-V6)
"465","data","P/F/N"	(MAP Norm Outlet,Norm Isolation- All leads)
"466","data","P/F/N"	(MAP Norm Outlet,Rev Isolation- All leads)
"475","data","P/F/N"	(MAP Rev Outlet, Norm Isolation- All leads)
"476","data","P/F/N"	(MAP Rev Outlet, Rev Isolation – All leads)
"480","data","P/F/N"	(MAP Norm Outlet,Norm Isolation- RA only)
"481","data","P/F/N"	(MAP Norm Outlet,Norm Isolation- RL only)
"482","data","P/F/N"	(MAP Norm Outlet,Norm Isolation- LA only)
"483","data","P/F/N"	(MAP Norm Outlet,Norm Isolation- LL only)
"484","data","P/F/N"	(MAP Norm Outlet,Norm Isolation- V1-V6 only)

ASCII CHARACTER FORMATS

Field	Description
"485","data","P/F/N"	(MAP Norm Outlet,Rev Isolation- RA only)
"486","data","P/F/N"	(MAP Norm Outlet,Rev Isolation- RL only)
"487","data","P/F/N"	(MAP Norm Outlet,Rev Isolation- LA only)
"488","data","P/F/N"	(MAP Norm Outlet,Rev Isolation- LL only)
"489","data","P/F/N"	(MAP Norm Outlet,Rev Isolation- V1-V6)
"490","data","P/F/N"	(MAP Rev Outlet, Norm Isolation- RA only)
"491","data","P/F/N"	(MAP Rev Outlet, Norm Isolation- RL only)
"492","data","P/F/N"	(MAP Rev Outlet, Norm Isolation- LA only)
"493","data","P/F/N"	(MAP Rev Outlet, Norm Isolation- LL only)
"494","data","P/F/N"	(MAP Rev Outlet, Norm Isolation- V1-V6 only)
"495","data","P/F/N"	(MAP Rev Outlet, Rev Isolation- RA only)
"496","data","P/F/N"	(MAP Rev Outlet, Rev Isolation- RL only)
"497","data","P/F/N"	(MAP Rev Outlet, Rev Isolation- LA only)
"498","data","P/F/N"	(MAP Rev Outlet, Rev Isolation- LL only)
"499","data","P/F/N"	(MAP Rev Outlet, Rev Isolation- V1-V6 only)
"500","data","P/F/N"	(Pat Aux Leak Normal RA-ALL)
"501","data","P/F/N"	(Pat Aux Leak Normal RL-ALL)
"502","data","P/F/N"	(Pat Aux Leak Normal LA-ALL)
"503","data","P/F/N"	(Pat Aux Leak Normal LL-ALL)
"504","data","P/F/N"	(Pat Aux Leak Normal V1-ALL)
"510","data","P/F/N"	(Pat Aux Leak No L2 RA-ALL)
"511","data","P/F/N"	(Pat Aux Leak No L2 RL-ALL)
"512","data","P/F/N"	(Pat Aux Leak No L2 LA-ALL)
"513","data","P/F/N"	(Pat Aux Leak No L2 LL-ALL)
"514","data","P/F/N"	(Pat Aux Leak No L2 V1-ALL)
"520","data","P/F/N"	(Pat Aux Leak No Earth RA-ALL)
"521","data","P/F/N"	(Pat Aux Leak No Earth RL-ALL)
"522","data","P/F/N"	(Pat Aux Leak No Earth LA-ALL)
"523","data","P/F/N"	(Pat Aux Leak No Earth LL-ALL)
"524","data","P/F/N"	(Pat Aux Leak No Earth V1-ALL)
"530","data","P/F/N"	(Pat Aux Leak Rev Pol RA-ALL)
"531","data","P/F/N"	(Pat Aux Leak Rev Pol RL-ALL)
"532","data","P/F/N"	(Pat Aux Leak Rev Pol LA-ALL)
"533","data","P/F/N"	(Pat Aux Leak Rev Pol LL-ALL)
"534","data","P/F/N"	(Pat Aux Leak Rev Pol V1-ALL)
"540","data","P/F/N"	(Pat Aux Leak Rev No L2 RA-ALL)
"541","data","P/F/N"	(Pat Aux Leak Rev No L2 RL-ALL)
"542","data","P/F/N"	(Pat Aux Leak Rev No L2 LA-ALL)
"543","data","P/F/N"	(Pat Aux Leak Rev No L2 LL-ALL)
"544","data","P/F/N"	(Pat Aux Leak Rev No L2 V1-ALL)
"550","data","P/F/N"	(Pat Ax Lk Rev No Earth RA-ALL)
"551","data","P/F/N"	(Pat Ax Lk Rev No Earth RL-ALL)
"552","data","P/F/N"	(Pat Ax Lk Rev No Earth LA-ALL)
"553","data","P/F/N"	(Pat Ax Lk Rev No Earth LL-ALL)
"554","data","P/F/N"	(Pat Ax Lk Rev No Earth V1-ALL)
"560","data","P/F/N"	(VDE 751.1Equiv Patient Leak)
"570","data","P/F/N"	(DC Patient Leak Normal- All to Earth)
"571","data","P/F/N"	(DC Patient Leak No L2- All to Earth)
"572","data","P/F/N"	(DC Patient Leak No Earth- All to Earth)
"573","data","P/F/N"	(DC Patient Leak Rev- All to Earth)
"574","data","P/F/N"	(DC Patient Leak Rev, No L2- All to Earth)

<b>Field</b>	<b>Description</b>
"575","data","P/F/N"	(DC Patient Leak Rev, No Earth- All to Earth)
"580","data","P/F/N"	(DC Patient Leak Normal- RA to Earth)
"581","data","P/F/N"	(DC Patient Leak No L2- RA to Earth)
"582","data","P/F/N"	(DC Patient Leak No Earth- RA to Earth)
"583","data","P/F/N"	(DC Patient Leak Rev- RA to Earth)
"584","data","P/F/N"	(DC Patient Leak Rev, No L2- RA to Earth)
"585","data","P/F/N"	(DC Patient Leak Rev, No Earth- RA Earth)
"590","data","P/F/N"	(DC Patient Leak Normal- RL to Earth)
"591","data","P/F/N"	(DC Patient Leak No L2- RL to Earth)
"592","data","P/F/N"	(DC Patient Leak No Earth- RL to Earth)
"593","data","P/F/N"	(DC Patient Leak Rev- RL to Earth)
"594","data","P/F/N"	(DC Patient Leak Rev, No L2- RL to Earth)
"595","data","P/F/N"	(DC Patient Leak Rev, No Earth- RL Earth)
"600","data","P/F/N"	(DC Patient Leak Normal- LA to Earth)
"601","data","P/F/N"	(DC Patient Leak No L2- LA to Earth)
"602","data","P/F/N"	(DC Patient Leak No Earth- LA to Earth)
"603","data","P/F/N"	(DC Patient Leak Rev- LA to Earth)
"604","data","P/F/N"	(DC Patient Leak Rev, No L2- LA to Earth)
"605","data","P/F/N"	(DC Patient Leak Rev, No Earth- LA Earth)
"610","data","P/F/N"	(DC Patient Leak Normal- LL to Earth)
"611","data","P/F/N"	(DC Patient Leak No L2- LL to Earth)
"612","data","P/F/N"	(DC Patient Leak No Earth- LL to Earth)
"613","data","P/F/N"	(DC Patient Leak Rev- LL to Earth)
"614","data","P/F/N"	(DC Patient Leak Rev, No L2- LL to Earth)
"615","data","P/F/N"	(DC Patient Leak Rev, No Earth- LL Earth)
"620","data","P/F/N"	(DC Patient Leak Normal- V1-V6 to Earth)
"621","data","P/F/N"	(DC Patient Leak No L2- V1-V6 to Earth)
"622","data","P/F/N"	(DC Patient Leak No Earth- V1-V6 to Earth)
"623","data","P/F/N"	(DC Patient Leak Rev- V1-V6 to Earth)
"624","data","P/F/N"	(DC Patient Leak Rev, No L2- V1-V6 to Earth)
"625","data","P/F/N"	(DC Patient Leak Rev, No Earth- V1-V6 Earth)
"640","data","P/F/N"	(Pat Aux Leak DC Normal RA-ALL)
"641","data","P/F/N"	(Pat Aux Leak DC Normal RL-ALL)
"642","data","P/F/N"	(Pat Aux Leak DC Normal LA-ALL)
"643","data","P/F/N"	(Pat Aux Leak DC Normal LL-ALL)
"644","data","P/F/N"	(Pat Aux Leak DC Normal V1-ALL)
"650","data","P/F/N"	(Pat Aux Leak DC No L2 RA-ALL)
"651","data","P/F/N"	(Pat Aux Leak DC No L2 RL-ALL)
"652","data","P/F/N"	(Pat Aux Leak DC No L2 LA-ALL)
"653","data","P/F/N"	(Pat Aux Leak DC No L2 LL-ALL)
"654","data","P/F/N"	(Pat Aux Leak DC No L2 V1-ALL)
"660","data","P/F/N"	(Pat Aux Leak DC No Earth RA-ALL)
"661","data","P/F/N"	(Pat Aux Leak DC No Earth RL-ALL)
"662","data","P/F/N"	(Pat Aux Leak DC No Earth LA-ALL)
"663","data","P/F/N"	(Pat Aux Leak DC No Earth LL-ALL)
"664","data","P/F/N"	(Pat Aux Leak DC No Earth V1-ALL)
"670","data","P/F/N"	(Pat Aux Leak DC Rev Pol RA-ALL)
"671","data","P/F/N"	(Pat Aux Leak DC Rev Pol RL-ALL)
"672","data","P/F/N"	(Pat Aux Leak DC Rev Pol LA-ALL)
"673","data","P/F/N"	(Pat Aux Leak DC Rev Pol LL-ALL)
"674","data","P/F/N"	(Pat Aux Leak DC Rev Pol V1-ALL)

ASCII CHARACTER FORMATS

Field	Description
"680","data","P/F/N"	(Pat Aux Leak DC Rev No L2 RA-ALL)
"681","data","P/F/N"	(Pat Aux Leak DC Rev No L2 RL-ALL)
"682","data","P/F/N"	(Pat Aux Leak DC Rev No L2 LA-ALL)
"683","data","P/F/N"	(Pat Aux Leak DC Rev No L2 LL-ALL)
"684","data","P/F/N"	(Pat Aux Leak DC Rev No L2 V1-ALL)
"690","data","P/F/N"	(Pat Aux Leak DC Rev No Earth RA-ALL)
"691","data","P/F/N"	(Pat Aux Leak DC Rev No Earth RL-ALL)
"692","data","P/F/N"	(Pat Aux Leak DC Rev No Earth LA-ALL)
"693","data","P/F/N"	(Pat Aux Leak DC Rev No Earth LL-ALL)
"694","data","P/F/N"	(Pat Aux Leak DC Rev No Earth V1-ALL)
"700","data","P/F/N"	(Accessible Voltage Normal)
"701","data","P/F/N"	(Accessible Voltage No L2)
"702","data","P/F/N"	(Accessible Voltage No Earth)
"703","data","P/F/N"	(Accessible Voltage Rev Pol)
"704","data","P/F/N"	(Accessible Voltage Rev No L2)
"705","data","P/F/N"	(Accessible Voltage Rev No Earth)
"710","data","P/F/N"	(Accessible Leakage Normal)
"711","data","P/F/N"	(Accessible Leakage No L2)
"712","data","P/F/N"	(Accessible Leakage No Earth)
"713","data","P/F/N"	(Accessible Leakage Rev Pol)
"714","data","P/F/N"	(Accessible Leakage Rev No L2)
"715","data","P/F/N"	(Accessible Leakage Rev No Earth)
"720","data","P/F/N"	(Accessible Leakage DC Normal)
"721","data","P/F/N"	(Accessible Leakage DC No L2)
"722","data","P/F/N"	(Accessible Leakage DC No Earth)
"723","data","P/F/N"	(Accessible Leakage DC Rev Pol)
"724","data","P/F/N"	(Accessible Leakage DC Rev No L2)
"725","data","P/F/N"	(Accessible Leakage DC Rev No Earth)
PASS/FAIL	(Overall Test data)
Comments	(Comment Field)

601PRO SERIES<sub>XL</sub>