



DEFIBRILLATOR ANALYZERS



DA-2006



**DA-2006P
W/ PACER
ANALYZER**

SERVICE MANUAL

**BC BIOMEDICAL
SERVICE MANUAL
DA-2006 SERIES
TABLE OF CONTENTS**

WARNINGS, CAUTIONS, NOTICESii

MANUAL REVISIONSiv

WARRANTYiv

MANUALS

DA-2006 Series User Manual (Rev 06) SECTION A

DA-CS-06 (Rev 02) SECTION A

OPERATIONAL THEORY SECTION B

VALIDATION / CALIBRATION SECTION C

PARTS SECTION D

This Service Manual covers the following units:

- DA-2006
- DA-2006P

CAUTION - SERVICE

The DA-2006 Series Analyzers are intended to be serviced only by authorized service personnel.

Troubleshooting and service procedures should only be performed by qualified technical personnel.

WARNING - MODIFICATIONS

The DA-2006 Series Analyzers are intended for use within the published specifications. Any application beyond these specifications or any unauthorized user modifications may result in hazards or improper operation.

NOTICE – DISCLAIMER

USER ASSUMES FULL RESPONSIBILITY FOR UNAUTHORIZED EQUIPMENT MODIFICATIONS OR APPLICATION OF EQUIPMENT OUTSIDE OF THE PUBLISHED INTENDED USE AND SPECIFICATIONS. SUCH MODIFICATIONS OR APPLICATIONS MAY RESULT IN EQUIPMENT DAMAGE OR PERSONAL INJURY.

NOTICE – DISCLAIMER

BC GROUP INTERNATIONAL, INC. RESERVES THE RIGHT TO MAKE CHANGES TO ITS PRODUCTS OR SPECIFICATIONS AT ANY TIME, WITHOUT NOTICE, IN ORDER TO IMPROVE THE DESIGN OR PERFORMANCE AND TO SUPPLY THE BEST POSSIBLE PRODUCT. THE INFORMATION IN THIS MANUAL HAS BEEN CAREFULLY CHECKED AND IS BELIEVED TO BE ACCURATE. HOWEVER, NO RESPONSIBILITY IS ASSUMED FOR INACCURACIES.

NOTICE – CONTACT INFORMATION

BC BIOMEDICAL
BC GROUP INTERNATIONAL, INC.
PO BOX 25125
9415 GENTRY AVE
ST. LOUIS, MO 63125
USA

1-800-242-8428
314-638-3800

www.bcgrouptl.com
sales@bcgrouptl.com

MANUAL REVISIONS

<u>Revision #</u>	<u>Engineering #</u>	<u>Revisions Made</u>
Rev 01	7395	Origination
Rev 02	395	Drawing scans inserted

LIMITED WARRANTY

WARRANTY: BC GROUP INTERNATIONAL, INC. WARRANTS ITS NEW PRODUCTS TO BE FREE FROM DEFECTS IN MATERIALS AND WORKMANSHIP UNDER THE SERVICE FOR WHICH THEY ARE INTENDED. THIS WARRANTY IS EFFECTIVE FOR TWELVE MONTHS FROM THE DATE OF SHIPMENT.

EXCLUSIONS: THIS WARRANTY IS **IN LIEU OF** ANY OTHER WARRANTY EXPRESSED OR IMPLIED, INCLUDING, BUT NOT LIMITED TO ANY IMPLIED WARRANTY OF **MERCHANTABILITY** OR FITNESS FOR A PARTICULAR PURPOSE.

BC GROUP INTERNATIONAL, INC. IS NOT LIABLE FOR ANY INCIDENTAL OR CONSEQUENTIAL DAMAGES.

NO PERSON OTHER THAN AN OFFICER IS AUTHORIZED TO GIVE ANY OTHER WARRANTY OR ASSUME ANY LIABILITY.

REMEDIES: THE PURCHASER'S SOLE AND EXCLUSIVE REMEDY SHALL BE: (1) THE REPAIR OR REPLACEMENT OF DEFECTIVE PARTS OR PRODUCTS, WITHOUT CHARGE. (2) AT THE OPTION OF **BC GROUP INTERNATIONAL, INC.**, THE REFUND OF THE PURCHASE PRICE.

**SECTION A
USER MANUAL
DA-2006 SERIES
REV 06**



DEFIBRILLATOR ANALYZERS



DA-2006



**DA-2006P
W/ PACER
ANALYZER**

USER MANUAL

BC BIOMEDICAL DA-2006 SERIES TABLE OF CONTENTS

WARNINGS, CAUTIONS, NOTICES	2
DESCRIPTION.....	7
OVERVIEW.....	15
DEFIBRILLATOR ANALYZER	23
MAIN SCREEN.....	23
ECG WAVEFORMS SCREEN	31
PLAYBACK LAST PULSE SCREEN	35
START CHARGE TIMER SCREEN	37
PRINT HEADER.....	39
SELF TEST WAVEFORM	41
RUNNING A DEFIBRILLATION TEST	43
INTRODUCTION	43
DEFIBRILLATION TEST.....	45
CARDIOVERSION TEST.....	49
CHARGE TIME TEST.....	53
SHOCK ADVISORY ALGORITHM TEST	55
TRANSCUTANEOUS PACEMAKER ANALYZER	57
PACE MAIN SCREEN	57
PACER MODE SETUP SCREEN.....	63
SENSITIVITY TEST	65
REFRACTORY PERIOD TEST	67
PRINT MENU SCREEN	69
PLAYBACK LAST PULSE SCREEN	71

MESSAGES	73
SYSTEM SETUP.....	75
POWER UP SETTINGS.....	77
AUTO SEQUENCE FUNCTION.....	79
VIEW MODE	81
RUN MODE.....	85
PROGRAMMING AUTO SEQUENCES.....	95
MANUAL REVISIONS.....	107
WARRANTY.....	107
SPECIFICATIONS	109
NOTES.....	115

WARNING - USERS

The DA-2006 Series Analyzers are for use by skilled technical personnel only.

WARNING - USE

The DA-2006 Series Analyzers are intended for testing only and they should never be used in diagnostics, treatment or any other capacity where they would come in contact with a patient.

WARNING - MODIFICATIONS

The DA-2006 Series Analyzers are intended for use within the published specifications. Any application beyond these specifications or any unauthorized user modifications may result in hazards or improper operation.

WARNING - CONNECTIONS

All connections to patients must be removed before connecting the Device Under Test (DUT) to the Analyzer. A serious hazard may occur if the patient is connected when testing with the Analyzer.

Do not connect any leads from the patient directly to the Analyzer or DUT.

WARNING - POWER ADAPTOR

Unplug the Power Adaptor before cleaning the surface of the Analyzer.

WARNING - LIQUIDS

Do not submerge or spill liquids on the Analyzer. Do not operate the Analyzer if internal components not intended for use with fluids may have been exposed to fluid, as the internal leakage may have caused corrosion and be a potential hazard.

CAUTION - SERVICE

The DA-2006 Series Analyzers are intended to be serviced only by authorized service personnel. Troubleshooting and service procedures should only be performed by qualified technical personnel.

CAUTION - ENVIRONMENT

The DA-2006 Series Analyzers are intended to function between 15 and 40 °C. Exposure to temperatures outside this range can adversely affect the performance of the Analyzer.

CAUTION - CLEANING

Do not immerse. The Analyzer should be cleaned by wiping gently with a damp, lint-free cloth.

CAUTION - INSPECTION

The DA-2006 Series Analyzers should be inspected before each use for wear and the Analyzer should be serviced if any parts are in question.

NOTICE – SYMBOLS

Symbol

Description



Caution
(Consult Manual for Further Information)



Center Positive



Direct Current

NOTICE – ABBREVIATIONS

A, Amps	Amperes
BPM	Beats Per Minute
c	centi- (10^{-2})
C	Celsius
°	degree
dt	Delta Time, Change in Time
DUT	Device Under Test
E	Energy
ECG	Electrocardiogram
Euro	European
Hz	hertz
J	Joules
k	kilo- (10^3)
kg	kilograms
lbs	pounds
μ	micro- (10^{-6})
μA	microampere
μH	microhertz
μV	microvolt
μsec	microsecond
m	milli- (10^{-3})-
mA	milliampere
mm	millimeter
ms, mS, msec	millisecond
mV	millivolts
Ω	ohm
P	Power
ppm	pulse per minute
R	Resistance, ohms
Sec, S	seconds
US	United States
V	volt
VDC	Direct Current Voltage

NOTICE – DISCLAIMER

USER ASSUMES FULL RESPONSIBILITY FOR UNAUTHORIZED EQUIPMENT MODIFICATIONS OR APPLICATION OF EQUIPMENT OUTSIDE OF THE PUBLISHED INTENDED USE AND SPECIFICATIONS. SUCH MODIFICATIONS OR APPLICATIONS MAY RESULT IN EQUIPMENT DAMAGE OR PERSONAL INJURY.

NOTICE – DISCLAIMER

BC GROUP INTERNATIONAL, INC. RESERVES THE RIGHT TO MAKE CHANGES TO ITS PRODUCTS OR SPECIFICATIONS AT ANY TIME, WITHOUT NOTICE, IN ORDER TO IMPROVE THE DESIGN OR PERFORMANCE AND TO SUPPLY THE BEST POSSIBLE PRODUCT. THE INFORMATION IN THIS MANUAL HAS BEEN CAREFULLY CHECKED AND IS BELIEVED TO BE ACCURATE. HOWEVER, NO RESPONSIBILITY IS ASSUMED FOR INACCURACIES.

NOTICE – CONTACT INFORMATION

BC BIOMEDICAL
BC GROUP INTERNATIONAL, INC.
PO BOX 25125
9415 GENTRY AVE
ST. LOUIS, MO 63125
USA

1-800-242-8428
314-638-3800

www.bcgrouptl.com
sales@bcgrouptl.com

**BC GROUP
DA-2006 SERIES
DEFIBRILLATOR ANALYZER**

The Model DA-2006 Series is a microprocessor-based instrument family that is used in the testing of defibrillators. They measure the energy output and provide information about the defibrillation pulse. They are used on manual, semi-automatic and automatic defibrillators with monophasic or biphasic outputs.

The DA-2006P model additionally provides a Transcutaneous Pacemaker analysis function. It measures and displays pacer pulse information as well as performing Refractory Period, Sensitivity and Immunity testing.

All models have a built in 50 ohm human body simulation load as well as 12 lead ECG with arrhythmias and performance waveforms. Additionally, they have a Centronics printer port, a serial port, oscilloscope output, high-level ECG output, as well as provision for a battery eliminator.

The DA-2006 Series makes viewing and selecting the desired waveforms and test data quick and intuitive, with all operational information being available on the 240 by 64 pixel graphic display, allowing for easy maneuvering through parameters and scrolling through available options.

NOTE: The instrument is intended for use by trained service technicians.

The following are highlights of some of the main features:

GENERAL

- SIMPLE TO OPERATE
- GRAPHICS DISPLAY WITH SIMULTANEOUS DETAILED STATUS OF PARAMETERS AND SCROLLING CONTROL OF OPTIONS
- ON SCREEN VIEWING OF DEFIBRILLATOR AND PACEMAKER WAVEFORMS
- DROP DOWN CHOICE SCREENS LIST ALL OPTIONS FOR PARAMETERS
- MONOPHASIC AND BIPHASIC COMPATIBLE
- 5000 V, 1000 JOULE CAPACITY
- HIGH AND LOW RANGES
- CARDIOVERSION DELAY MEASUREMENT
- CHARGE TIME MEASUREMENT
- WAVEFORM STORAGE AND PLAYBACK
- 10 UNIVERSAL PATIENT LEAD CONNECTORS
- 25 PIN CONNECTOR FOR CENTRONICS PRINTER
- 9 VOLT BATTERY POWER
- LOW BATTERY INDICATOR
- AVAILABLE BATTERY ELIMINATOR
- DISPLAY BACKLIGHT
- FULL REMOTE OPERATION VIA RS-232
- FLASH PROGRAMMABLE FOR UPGRADES
- AUTO SEQUENCE TESTING CAPABLE OF STORING 50 CUSTOM TEST SEQUENCES

PACEMAKER OPTION

- 26 SELECTABLE INTERNAL LOADS
- FULL PULSE ANALYSIS
- DEMAND SENSITIVITY TEST
- REFRACTORY PERIOD TESTS
- 50/60 Hz INTERFERENCE TEST SIGNALS
- INPUT TERMINALS AND CIRCUITRY PROTECTED AGAINST ACCIDENTAL DEFIBRILLATOR DISCHARGE INTO PACEMAKER TEST TERMINALS

ENERGY OUTPUT MEASUREMENT GENERAL

The unit measures the energy in the output pulse of both monophasic and biphasic defibrillators.

- PULSE TYPE: Monophasic or Biphasic
- LOAD RESISTANCE: 50 ohm +/- 1%, non-inductive (<1 μ H)
- DISPLAY RESOLUTION: 0.1 Joules
- MEASUREMENT TIME WINDOW: 100 ms
- ABSOLUTE MAX PEAK VOLTAGE: 6000 Volts
- CARDIOVERSION DELAY: 0 to 6000 ms
- CARDIOVERSION RESOLUTION: 0.1 ms

ENERGY OUTPUT MEASUREMENT HIGH RANGE

The high range allows for a large pulse with high voltage and current.

- VOLTAGE: \leq 5000 Volts
- MAX CURRENT: 120 Amps
- MAX ENERGY: 1000 Joules
- TRIGGER LEVEL: 100 Volts
- PLAYBACK AMPLITUDE: 1 mV / 1000 V Lead I
- TEST PULSE: 125 Joules +/- 20%

ENERGY OUTPUT MEASUREMENT LOW RANGE

The low range allows greater resolution on smaller pulses.

- VOLTAGE: <1000 Volts
- MAX CURRENT: 24 Amps
- MAX ENERGY: 50 Joules
- TRIGGER LEVEL: 20 Volts
- PLAYBACK AMPLITUDE: 1 mV / 1000 V Lead I
- TEST PULSE: 5 Joules +/- 20%

ENERGY OUTPUT MEASUREMENT OTHER

OSCILLOSCOPE OUTPUT

- HIGH MEASUREMENT RANGE: 1000:1 amplitude-attenuated
- LOW MEASUREMENT RANGE: 200:1 amplitude-attenuated

WAVEFORM PLAYBACK

- OUTPUT – LEAD 1 & PLATES
- GRAPHICS SCREEN
- 200:1 Time Base Expansion

SYNC TIME MEASUREMENTS

- TIMING WINDOW: Starts at peak of each R-wave
- TEST WAVEFORMS: All waveform simulations available

CHARGE TIME MEASUREMENT

- From 0 .1 to 99.9 sec

ECG FUNCTIONS

The unit can produce a wide variety of ECG simulations. The user simply selects the parameters that match the desired output.

- RATE: 30,40,45,60,80,90,100,120,140,160,180,200,220,240,260,280,300 BPM
- AMPLITUDE: 0.50,1.0,1.5,2.0 mV (Lead II)

ECG-PERFORMANCE FUNCTIONS

The unit can generate Sine, Square, Triangular, and Pulse waveforms with adjustable amplitudes for performance testing.

- SINE: 0.1,0.2,0.5,5,10,40,50,60,100 Hz
- SQUARE: 0.125,2 Hz
- TRIANGLE: 2,2.5 Hz
- PULSE: 30,60,120 BPM; 60 ms WIDTH
- AMPLITUDE: 0.5,1.0,1.5,2.0 mV (Lead II)

ARRHYTHMIA FUNCTIONS

The unit can simulate 12 different arrhythmias.

- VENTRICULAR FIBRILLATION
- ATRIAL FIBRILLATION
- SECOND DEGREE A-V BLOCK
- RIGHT BUNDLE BRANCH BLOCK
- PREMATURE ATRIAL CONTRACTION
- EARLY PVC
- STANDARD PVC
- R ON T PVC
- MULTIFOCAL PVC
- BIGEMINY
- RUN OF 5 PVC
- VENTRICULAR TACHYCARDIA

SHOCK ADVISORY TESTS

The unit can simulate 8 different waveforms to test the shock algorithm of advanced defibrillators:

- ASYSTOLE
- COARSE VENTRICULAR FIBRILLATION
- FINE VENTRICULAR FIBRILLATION
- MULTIFOCAL VENTRICULAR TACHYCARDIA @ 140 BPM
- MULTIFOCAL VENTRICULAR TACHYCARDIA @ 160 BPM
- POLYFOCAL VENTRICULAR TACHYCARDIA @ 140 BPM
- POLYFOCAL VENTRICULAR TACHYCARDIA @ 160 BPM
- SUPRAVENTRICULAR TACHYCARDIA @ 90 BPM

TRANSCUTANEOUS PACER ANALYZER

The unit can test external transcutaneous pacemakers. It has a wide variety of loads and can measure the Pacer Pulse, Demand Sensitivity and Refractory Periods (Pacing and Sensing):

- LOAD:
 - RANGE: 50,100,150,200,300,400,500,600,700,800,900,1000,1100,1200,1300,1400,1500,1600,1700,1800,1900,2000,2100,2200,2300 ohm
- PULSE:
 - PULSE CURRENT: 4 TO 300 mA (100 ohm load)
 - RATE: 30 TO 800 ppm
 - WIDTH: 0.6 to 80 ms
- DEMAND SENSITIVITY:
 - WAVEFORMS:
 - SELECTIONS: SQUARE, TRIANGLE, HAVERSINE
 - WIDTH: 10,25,40,100,200 ms
 - ECG:
 - AMPLITUDE – OUT: 0 to 4 mV
 - PACER INPUT (50 TO 400 OHM):
 - AMPLITUDE – OUT: 0 to 10 mV / 50 ohms
 - RATE – IN: 30 to 120 ppm
 - PACER INPUT (500 TO 2300 OHM & OPEN):
 - AMPLITUDE – OUT: 0 to 100 mV
 - RATE – IN: 30 to 120 ppm
 - DEFIBRILLATOR PLATES:
 - AMPLITUDE – OUT: 0 to 10 mV
 - RATE – IN: 30 to 120 ppm
- REFRACTORY PERIOD:
 - PACING: 20 to 500 ms
 - SENSING: 20 to 500 ms
- 50/60 HZ INTERFERENCE TEST SIGNAL:
 - ECG OUTPUT: 0,0.4,0.8,1.2,1.6,2.0,2.4,2.8,3.2,3.6,4.0 mV
 - PACER INPUT 50 OHM: 0,1,2,3,4,5,6,7,8,9,10 mV
 - PACER INPUT 100 OHM: 0,2,4,6,8,10,12,14,16,18,20 mV
 - PACER INPUT 150 OHM: 0,3,6,9,12,15,18,21,24,27,30 mV
 - PACER INPUT 200 OHM: 0,4,8,12,16,20,24,28,32,26,40 mV
 - PACER INPUT 300 OHM: 0,6,12,18,24,30,36,42,48,54,60 mV
 - PACER INPUT 400 OHM: 0,8,16,24,32,40,48,56,64,72,80 mV
 - PACER INPUT \geq 500 OHM: 0,10,20,30,40,50,60,70,80,90,100 mV
 - DEFIBRILLATOR PLATES: 0,1,2,3,4,5,6,7,8,9,10 mV
- INPUT CIRCUITRY PROTECTION
 - INPUT CIRCUITRY IS PROTECTED AGAINST DAMAGE IN THE EVENT OF AN ACCIDENTAL DEFIBRILLATOR DISCHARGE INTO THE PACEMAKER TEST INPUT TERMINALS

ACCESSORIES

BC20 - 40032	INTERNAL PADDLE ADAPTERS (2 adapters)
BC20 - 21103	BATTERY ELIMINATOR (120 VAC) (US Version)
BC20 - 21101	BATTERY ELIMINATOR (220 VAC) (Euro Version)
BC20 - 00427	PLASTIC ELECTRODE PLATES (2 plates)

OPTIONAL ACCESSORIES

BC20 - 30108	BC BIOMEDICAL MEDIUM SOFT SIDED CARRYING CASE
BC20 - 41341	COMMUNICATION CABLE (DB 9 M to DB 9 F)
BC20 - 00420	PHYSIO-CONTROL DEFIB / PACE TEST CABLE
BC20 - 00421	MARQUETTE DEFIB / PACE TEST CABLE
BC20 - 00423	ZOLL DEFIB/PACE TEST CABLE
BC20 - 00424	PHYSIO-CONTROL PACE ONLY TEST CABLE
BC20 - 00425	ZOLL PACE ONLY TEST CABLE
BC20 - 00426	HP / AGILENT / LAERDAL / AAMI DEFIB / PACE TEST CABLE

This page intentionally left blank.

OVERVIEW

This section looks at the layout of a DA-2006 and gives descriptions of the elements that are present.

10 Universal Patient Lead Connectors:

- RA R
- LA L
- RL(-) N
- LL F
- V1 C1
- V2 C2
- V3 C3
- V4 C4
- V5 C5
- V6 C6

LCD Graphical Display:
Shows Parameters for Test Data and Waveforms

5 Light Touch Keys for Dynamic functions:

These keys are labeled in the bottom portion of the screen and change function based on operating mode.

Back Light Key
for turning on and off the backlight

Range Key
for selecting Defib input range high or low

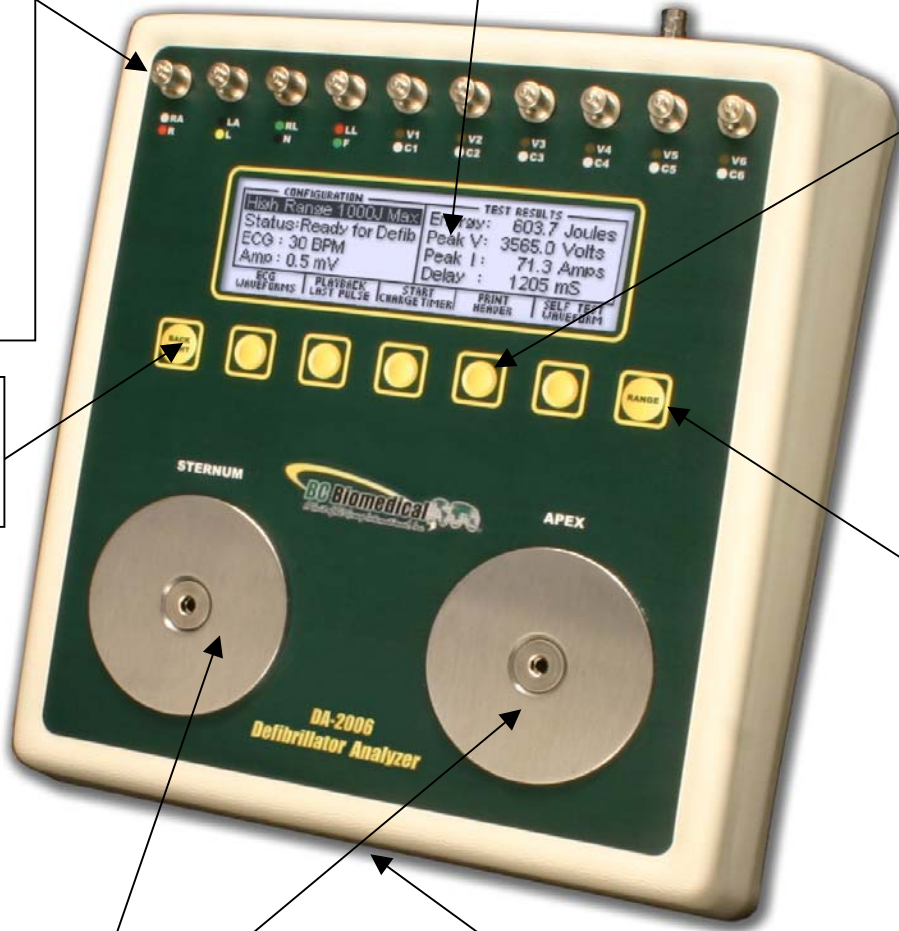

Large Defib Plates:
Fixed 50 ohm input load for Defibrillator testing

9V Battery Compartment
(Rear)

This section looks at the layout of a DA-2006P and gives descriptions of the elements that are present.

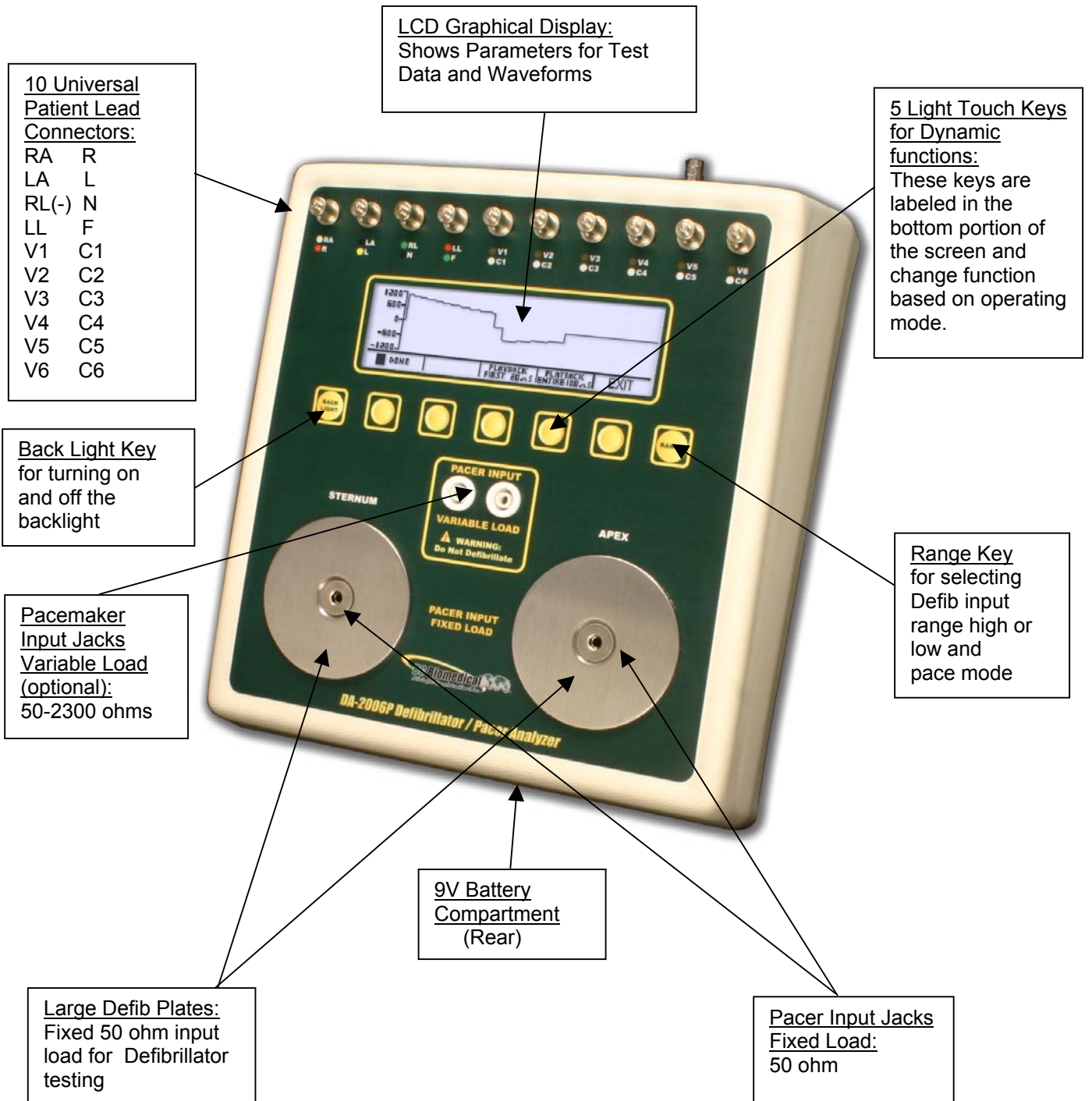

This section looks at the layout of the back and gives descriptions of the elements that are present.

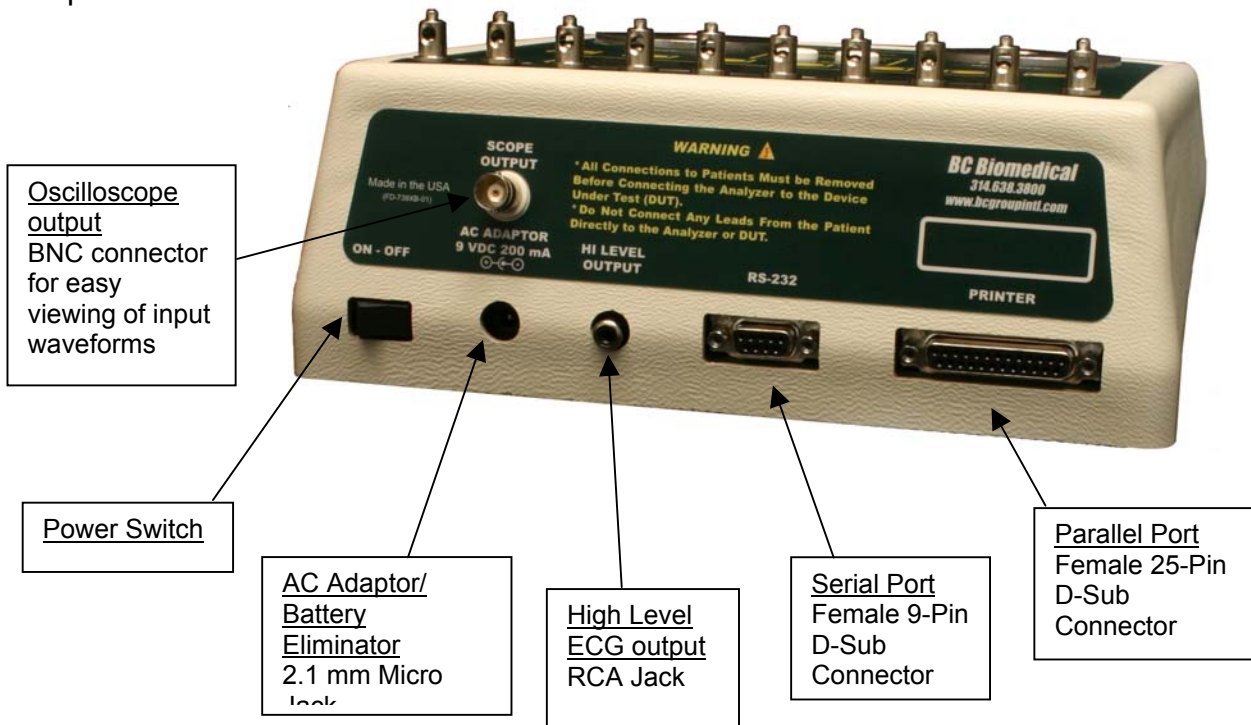

NOTE

The DA-2006 and the DA-2006P offer the same features, with the DA-2006P having the addition of a Transcutaneous Pacemaker Analyzer function (See Pacemaker Analyzer section for more details).

General Operation

The unit is controlled by 7 light touch keys. They allow the user to move around within the displayed parameters, select the desired options, choose a specific category and control the setup for the unit. When a key is depressed there is an audio click when it is accepted, or a razz tone if the key is invalid.

A large LCD graphics display with backlight provides the user with information about the current status of the device configuration options, test results and more. The display identifies the function of each key on a dynamic basis. As the operation mode changes, the key functions change to suit the operating mode.

Range Key

The  key scrolls through the ranges of the DA-2006 Series analyzers. Depressing the key will allow the user to select between High Defibrillator Range (1000J max), Low Defibrillator Range (50J max) and, with the DA-2006P, Pacemaker Range. The default mode on power up is High Defibrillator Range.

Backlight Key

The Graphic LCD display may be viewed with or without the backlight. Depressing any key will activate the backlight. However, since the backlight will drain the battery if left on, it will automatically shut off after a user programmable delay when running on battery power.

The  key is provided to toggle the backlight on or off at any time.

Function Keys

There are five  keys that are used to provide general operational control. The functions of the keys vary depending on the current screen. The section of the screen just above the key indicates its current meaning.

NOTE: Only functions that are available to the user will be visible at any given time.

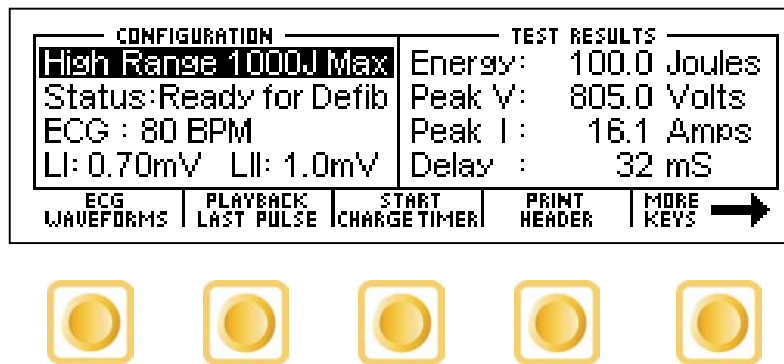

Sample Function Key Labeling

ECG Waveforms

The microprocessor has stored in its memory all of the digitalized waveforms. It sends the waveforms to a D/A converter, which generates an accurate analog representation. The waveform is then sent through resistor networks, developing the appropriate signals on the output terminals.

Universal Patient Lead Connectors

The 10 Universal Patient Lead Connectors allow for 12 lead ECG simulations. AHA and IEC color-coded labels are located on the face of the unit to aid in connecting the corresponding U.S. and International Patient Leads.

AHA Label	IEC Label	Description
RA	R	Right Arm
LA	L	Left Arm
RL	N	Right Leg (reference or ground)
LL	F	Left Leg
V1 V2 V3 V4 V5 V6	C1 C2 C3 C4 C5 C6	V Leads (V1-V6) (U.S. and Canada) also referred to as pericardial, precordial or unipolar chest leads Chest Leads (C1-C6) (International)

High Level Output (+)

A high level ECG output signal (200 X Amplitude Setting) is available on the RCA jack located on the rear of the unit.

Serial Port

A female 9-pin D-Sub connector is provided for the connection of the unit to a PC or laptop serial port (e.g. Com 1). This link is then used for either remote control or flash downloading of software upgrades.

Parallel Port

A female 25-pin D-Sub connector is provided for the connection of a printer via a Centronics parallel interface.

Oscilloscope Output

A BNC connector is provided to connect an oscilloscope to the unit. This output is a 200:1 attenuated version of the input to the Defibrillator Plates.

Power Switch

A rocker switch is provided on the rear of the unit to turn the power on and off.

Power Supply

The unit utilizes two 9 Volt Alkaline Batteries in the bottom battery compartments. When the unit detects a LOW BATTERY condition (10% Battery Life), a warning window will appear once per minute to alert the user.

Battery Eliminator

The unit has a 2.1 mm micro jack for connecting a 10-Volt AC battery eliminator. The adapter will power the unit, but will not charge the battery.

DEFIBRILLATOR ANALYZER

MAIN SCREEN

When the DA-2006 is first powered up, the Defibrillator Analyzer MAIN SCREEN will be displayed. This screen shows the current CONFIGURATION, the TEST RESULTS and the available FUNCTION KEYS. All defibrillator tests are run from the MAIN SCREEN. When the unit detects an input of greater than 100 Volts on the Defibrillator Plates (20 Volts in Low Range), it will automatically begin a test.

The default configuration is the High Range Defibrillator mode. This mode allows for a waveform of up to 1000 Joules to be analyzed.

The following is a sample screen for this mode:

CONFIGURATION		TEST RESULTS		
High Range 1000J Max		Energy:	100.0 Joules	
Status: Ready for Defib		Peak V:	805.0 Volts	
ECG : 80 BPM		Peak I:	16.1 Amps	
LI: 0.70mV LII: 1.0mV		Delay :	32 mS	
ECG WAVEFORMS	PLAYBACK LAST PULSE	START CHARGE/TIMER	PRINT HEADER	MORE KEYS →

Defibrillator Analyzer

The  key may be used to toggle the unit to the Low Range Defibrillator mode. This mode allows for waveforms up to 50 Joules to be analyzed. The Defibrillator Analyzer works the same in both ranges. The lower range simply provides for a higher resolution for pulses with smaller amplitudes.

The following is a sample screen for this mode:

CONFIGURATION		TEST RESULTS		
Low Range	50J Max	Energy:	20.4 Joules	
Status:	Ready for Defib	Peak V:	367.5 Volts	
ECG :	80 BPM	Peak I :	7.4 Amps	
LI:	0.70mV	LI:	1.0mV	
Delay :	394 mS			
ECG WAVEFORMS	PLAYBACK LAST PULSE	START CHARGE/TIMER	PRINT HEADER	MORE KEYS →

NOTE: The  key will also put the DA-2006P into the Transcutaneous Pacemaker Analyzer mode (See Pacemaker Analyzer section for more information).

CONFIGURATION

The CONFIGURATION section of the MAIN SCREEN displays the current setup of the unit.

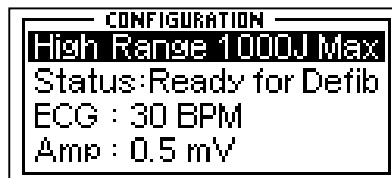

RANGE

The first line displays the range value for the pulse. It may be either 1000 Joules or 50 Joules max. This setting may be changed using the  key.

NOTE: This line also allows for the selection of the Pacer Analyzer that is an option available in the DA-2006P model. The  key will toggle to Pacer to put the unit into the Pacemaker Analyzer mode (See Pacemaker Analyzer section for more information).

STATUS

This line provides information about the current status of the analyzer.

ECG

This line displays the selection that is active on the ECG terminals. This setting may be changed in the ECG WAVEFORMS screen.

AMP

This line displays the amplitude that has been selected for the ECG terminals. This setting may be changed in the ECG WAVEFORMS screen.

TEST RESULTS

The TEST RESULTS section of the MAIN SCREEN displays the results of the last pulse. It will continue to be displayed until the power is turned off, another test is run or the range is changed.

TEST RESULTS	
Energy:	603.7 Joules
Peak V:	3565.0 Volts
Peak I:	71.3 Amps
Delay :	1205 mS

NOTE: The unit automatically starts a test when it sees a voltage greater than 100 Volts on the Defibrillator Plates (20 Volts in Low Range).

NOTE: Test results are immediately sent to the printer port as soon as the data is available.

ENERGY

This line displays the total energy of the last pulse.

PEAK V

This line displays the peak voltage of the last pulse.

PEAK I

This line displays the peak current of the last pulse.

DELAY

This line normally displays the delay from the peak of the R wave until the start of the Defib Energy pulse. The line is replaced by the CHARGE TIME if this test has been run (see START CHARGE TIMER SCREEN for more information).

CHG TIME

This line displays if the Charge Timer has been run. It shows the time required to charge the Device Under Test (DUT). This test is started with the  key.

FUNCTION KEYS

The FUNCTION KEYS section of the MAIN SCREEN displays the current functions of the keys found below the display. These keys allow for navigation to supporting screens and initiation of specific features.

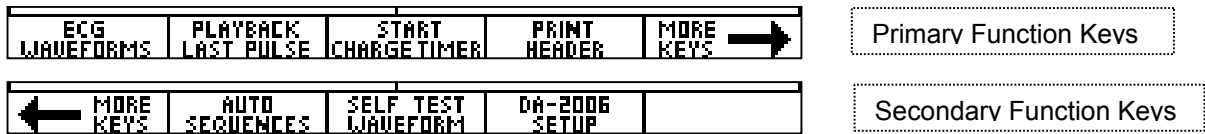

ECG WAVEFORMS

This key enters the ECG WAVEFORMS screen where all ECG parameters are set.

PLAYBACK LAST PULSE

This key enters the PLAYBACK LAST PULSE screen where a graphical representation of the last pulse may be viewed and sent out.

START CHARGE TIMER

This key brings up the CHARGE TIMER screen and starts the pre-warn timer. It is used to test the charge time for the defibrillator.

PRINT HEADER

This key sends the Report Header to the printer.

MORE KEYS

These keys toggle between the Primary and Secondary Function Keys.

AUTO SEQUENCES

This key brings up the AUTO SEQUENCE MENU, which is used to view or run the Auto Sequences stored in the unit.

SELF TEST WAVEFORM

This key sends an internal test pulse to the unit, allowing for the display of the results to give an indication that the system is working properly.

DA-2006 SETUP

This key brings up the SYSTEM CONFIGURATION SCREEN, which allows for adjusting the various system configuration parameters.

This page intentionally left blank.

ECG WAVEFORMS SCREEN

The DA-2006 ECG output can be connected in 3, 5 or 12 lead configurations. Pressing the ECG WAVEFORMS key from the MAIN SCREEN will allow the user to configure the waveform that is used for the ECG output.

The following is a sample of the ECG waveform configuration screen:

ECG GROUP	WAVEFORM
Disabled	None
NSR	30,40,45,60,80,90,100,120,140,160,180,200,220,240,260,280,300 BPM
AED	Asystole
	Coarse Vfib
	Fine Vfib
	Multifocal Vtach 140
	Multifocal Vtach 160
	Polyfocal Vtach 140
	Polyfocal Vtach 160
Arrhythmias	SupraVent Tach 90
	Vfib
	Afib
	Second Deg Block
	RBBB
	PAC
	PVC Early
	PVC STD
	PVC R on T
	MF PVC
	Bigeminy
	Run of 5 PVC
	Vtach
	Performance
2, 2.5 Hz Triangle	
0.1,0.2,0.5,5,10,40,50,60,100 Hz Sine	
30, 60, 120 BPM	
Pulse	

ECG Configuration Screen

ECG Group: Disabled

Waveform: None

Amplitude : Lead I 0.70mV Lead II 1.0mV

▲ | ▼ | CHOICES | EXIT

AMPLITUDE

Lead I 0.35 mV Lead II 0.5 mV

Lead I 0.70 mV Lead II 1.0 mV

Lead I 1.05 mV Lead II 1.5 mV

Lead I 1.40 mV Lead II 2.0 mV

The ECG Group, Waveform and Amplitude can be selected using  to highlight the parameter and using **CHOICES** to open a drop down menu of all the options for the highlighted parameter.

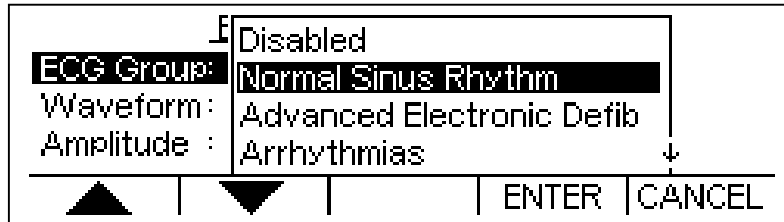

Use  to scroll to the desired option. Then **ENTER** is used to accept the new setting. The **CANCEL** key can be used to return to the ECG waveform configuration screen without making a new selection.

The **EXIT** key is used to return to the MAIN SCREEN.

The following is a brief description of how the DA-2006 simulates the available Arrhythmias:

Abbreviation	Arrhythmia	Description
Vent Fib – Fine	Ventricular Fibrillation	Irregular waveform with no real P-wave or clear R-R interval and a low signal level (Continuous)
Atrial Fib	Atrial Fibrillation	Absence of P-wave, irregular P-R interval rate and a high level signal (Continuous)
2nd Deg Heart Block	Second Degree Heart Block	80 BPM with increasing P-R interval for four beats (160, 220, 400, 470 ms) followed by a P wave without a QRS (Continuous)
Rt Bundle Branch Block	Right Bundle Branch Block	80 BPM with Normal P-wave and P-R interval but wider QRS complexes (Continuous)
PAC	Premature Atrial Contraction	NSR of 80 BPM with Periodic Abnormal 25% early P waves (PAC, 7 NSR) (Continuous)
PVC Early	Early Type 1 Premature Ventricular Contraction	NSR of 80 BPM with periodic left focus premature ventricular beats with 33% premature timing (PVC Type 1, 9 NSR) (Continuous)
PVC Std	Standard Type 1 Premature Ventricular Contraction	NSR of 80 BPM with periodic left focus premature ventricular beats with 20% premature timing (PVC Type 1, 9 NSR) (Continuous)
PVC R on T	R on T Type 1 Premature Ventricular Contraction	NSR of 80 BPM with periodic left focus premature ventricular beats with 65% premature timing, placing R on the previous T (PVC Type 1, 9 NSR) (Continuous)
Multifocal PVCS	Multifocal Premature Ventricular Contraction	NSR of 80 BPM with Type 1 and Type 2 PVCs (PVC Type 1, 2 NSR, PVC Type 2, 2 NSR) (Continuous)

Abbreviation	Arrhythmia	Description
Bigeminy	Bigeminal Rhythm	NSR of 80 BPM with every other beat a Type 1 PVC (Continuous)
Run of 5 PVCs	Run of 5 Premature Ventricular Contractions	NSR of 80 BPM with periodic group of 5 Type 1 PVCs (5 PVC Type 1, 36 NSR) (Continuous)
Vent Tach	Ventricular Tachycardia	160 BPM, No P-wave, Beats similar to Type 1 PVC (Continuous)



PLAYBACK LAST PULSE SCREEN

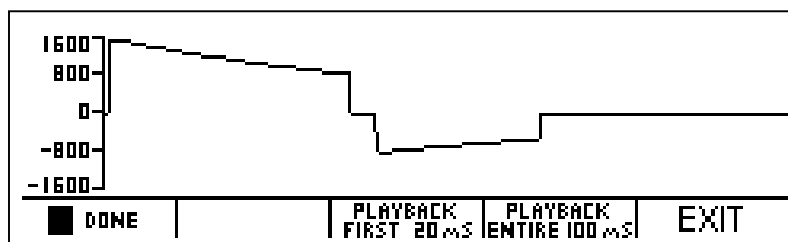

The DA-2006 can display a graphical representation of the last pulse. This screen may be accessed by pressing the  key from the Defibrillator Analyzer MAIN SCREEN. The playback allows the user to view the Defibrillator pulse in a time-expanded form. Samples are stored internally at 0.1 ms intervals. The PLAYBACK LAST PULSE SCREEN shows these samples expanded by a time factor of 200.

In playback mode, the samples are shown on the display and sent out the ECG leads, Defibrillator Plates and the High Level output. The following is a sample of the waveform that is shown in the display:





The scale shown on the screen is automatically adjusted to provide the maximum resolution available.

The  key can be used to pause the screen at any point while a pulse is being played back. This key replaces the  key when a pulse is being played back.

The  key can be used to play (continue) the waveform if it has been paused. This key replaces the  key.

Defibrillator Analyzer

The  key starts a playback of only the first 20 ms of the waveform.

The  key starts a playback of the entire 100 ms of the waveform.

At any time, the  key or  key can be depressed to return to the MAIN SCREEN.

START CHARGE TIMER SCREEN

A special timer has been incorporated into the DA-2006 to analyze the charging circuit of the Device Under Test (DUT). The START CHARGE TIMER SCREEN can be accessed by pressing the START CHARGE TIMER key from the MAIN SCREEN. To synchronize the charge timer with the defibrillator charge time, a Pre-Warning Countdown period is started. When the timer reaches zero, the defibrillator charge should be initiated. The following is an example of the countdown timer:

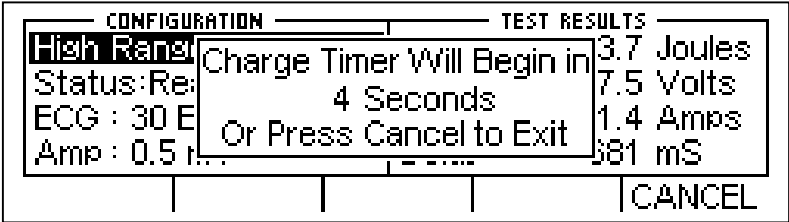

When the timer reaches zero, a beep will sound and the charge timer will begin counting up. The following is an example of the count up timer:

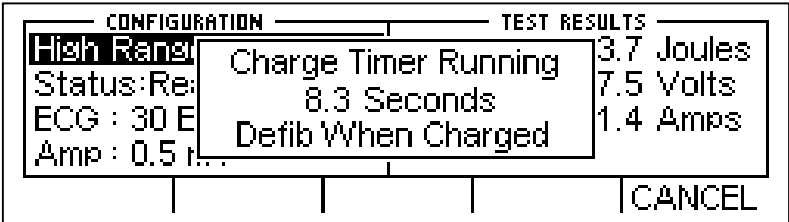

The DUT should be discharged as soon as it becomes charged. When the DUT is discharged, the timer will automatically stop. The display will show the results of the Defibrillator pulse analysis as well as the time required to charge the DUT:

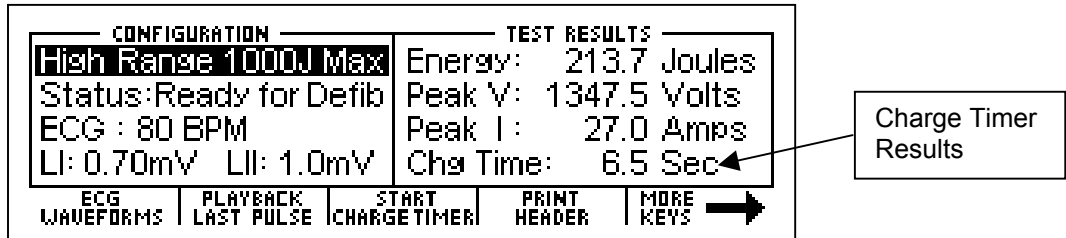

At any time, the key can be depressed to end the timer and return to the MAIN SCREEN.

PRINT HEADER

The DA-2006 provides a header for recording test data as well as the results of each pulse that is discharged into the unit. Test results are immediately sent to the printer port as soon as the data is available. The header is sent by pressing the  key from the MAIN SCREEN.

The status line of the configuration section will indicate that the header has been sent to the printer.

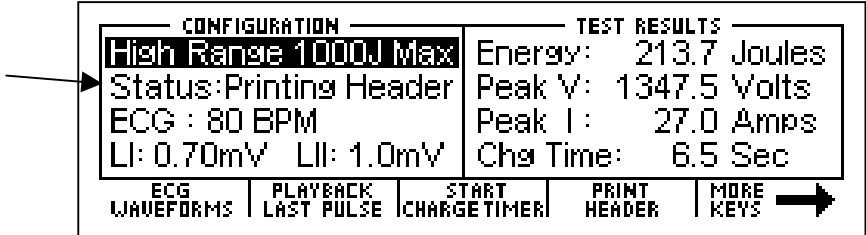

Defibrillator Analyzer

The following is the print header and sample data that are used for the Defibrillator Analyzer mode.

```

                                BC Biomedical
                                DA-2006 Defibrillator Analyzer

DA-2006 Serial Number: _____
Dut Manufacturer: _____
Dut Model: _____
Dut Serial Number: _____
Technician: _____
Location: _____

Date: _____

                                +----+
                                |      |
                                |      |
                                +----+
                                PASS

                                +----+
                                |      |
                                |      |
                                +----+
                                FAIL

Comments: _____
          _____
          _____

Test Data:
  Ecg      Ecg      Defib      Dut      +----+      DA-2006 Measurements:      ----+
Test# Wave   Amp     Load     Setting | Energy Voltage Current Dely/ChgT |
-----+-----+-----+-----+-----+-----+-----+
  1  None   1.0 mV  50ohm  _____J  112.5J  1085.0V  21.7A  0mS
  
```

NOTE: Printing the header also resets the test number printed on the data sheet.

NOTE: In the test results, the user must manually write the power setting of the DUT.

SELF TEST WAVEFORM

The DA-2006 has built in test waveforms that will give an indication that the system is working properly. The Self Test Waveform may be sent by pressing the SELF TEST WAVEFORM key from the MAIN SCREEN.

After the waveform has been sent, the results will be reflected in the test results section of the MAIN SCREEN and the PLAYBACK LAST PULSE SCREEN. The Self Test Waveform is not calibrated, but will provide a waveform that is approximately 125 Joules when configured for the High Range and 5 Joules when configured for the Low Range.

The following is an example of the MAIN SCREEN with the results of the Self Test Waveform:

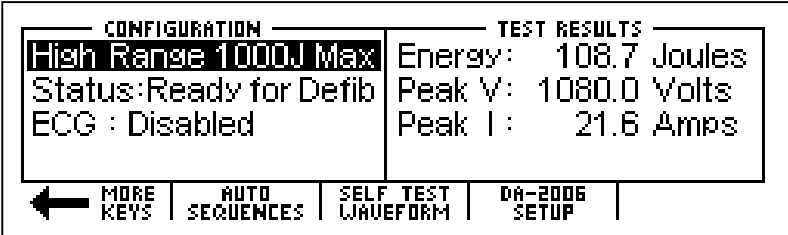

The following is an example of the PLAYBACK LAST PULSE SCREEN, showing a graphical representation of the Self Test Waveform:

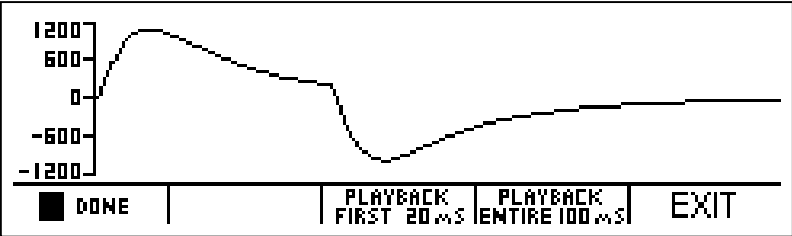

This page intentionally left blank.

RUNNING A DEFIBRILLATOR TEST

WARNING - CONNECTIONS

All connections to patients must be removed before connecting the Device Under Test (DUT) to the Analyzer. A serious hazard may occur if the patient is connected when testing with the Analyzer.

Do not connect any leads from the patient directly to the Analyzer or DUT.

INTRODUCTION

The DA-2006 will analyze the pulse output of a monophasic or biphasic defibrillator. The primary measure of the output is the Energy that it contains. Other information deals with the maximum voltage and current as well as the pulse timing with respect to the R-wave.

The human body has characteristic impedance that may vary, but 50 ohms is used for comparative defibrillator testing. The DA-2006 has a large internal 50 ohm non-inductive, high-power resistor to simulate a human body. It is sized to accept repeated pulses at the maximum energy levels.

The energy contained in a pulse is determined mathematically based on the fact that the energy is defined as the integral of the power curve. The following formulas describe the basic computation:

$$\text{Energy} = E = \int P \, dt$$

$$\text{Power} = P = V^2 / R \Rightarrow \int E = V^2 / R \, dt = \int V^2 \, dt / R$$

This computation is implemented digitally by taking timed samples of the voltage every 100 μ sec for 100 msec (1000 readings). Each value is then squared and divided by the resistance (50 ohms). The sum of these 1000 values times 10 is then the Energy in Joules (Watt Seconds) contained in the pulse.

DEFIBRILLATION TEST

The setup for a Defibrillation Test is dependent on the physical hardware involved. For the sake of this example we will assume a standard defibrillator with 5 lead ECG.

WARNING

This section is provided as a guide to familiarize the user with the DA-2006 Series. It is not intended to provide the necessary test sequence for every Defibrillator. The user must consult the manufacturer's manual for each DUT to determine the correct test procedure to follow.

- (1) Connect ECG leads to the corresponding universal connector on the DA-2006.

The connectors are marked with both the AHA and International color codes.

- (2) Turn on the DA-2006.

- (3) The unit will come up in the "High Range Defibrillator" mode. This range is used for normal adult testing.

NOTE: If it is desirable to run a test at 50 Joules or less with a peak voltage of 1000 Volts or less, the unit may be changed to the "Low Range Defibrillator" mode using the  key.

- (4) Select "Ventricular Fibrillation" from the ECG WAVEFORM SCREEN with an amplitude of 1 mV. This is necessary for most automatic defibrillators.

- (5) Place the Defibrillator Paddles on the DA-2006 contact plates. The APEX is on the right and the STERNUM is on the left.

NOTE: Reversing the paddles will not cause any damage to the unit or error in the energy reading. However, it will cause the polarity of the oscilloscope output and the playback waveform to be inverted.

- (6) Holding the paddles firmly in place, charge the Defibrillator and discharge it into the DA-2006.

WARNING

Observe all precautions noted by the Defibrillator Manufacturer when using the Defibrillator.

- (7) The DA-2006 will automatically sense the voltage rise across the internal 50 ohm load and begin taking readings. After the sampling is done (100 ms) the unit will compute and display the results.

- a. The power pulse is available at the oscilloscope output in real time at 200:1 signal attenuation when in low range and 1000:1 signal attenuation when in high range.
- b. After the computation, the pulse is automatically played back at a 200:1 time base expansion (200 times slower) on both the ECG leads and the Paddle plates. The signal level is 1 mV per 1000 Volts on Lead 1.
- c. At the same time, the test results are sent to the printer.

(8) The Status line will change to indicate the various steps as they are being done.

(9) At the end of the process the results are continuously displayed in the Test Results section of the MAIN SCREEN. They will remain there until another test is performed, the range is changed or the power is turned off.

(10) The user may repeat the playback of the waveform at any time by changing to the PLAYBACK LAST PULSE SCREEN using the  key. In this screen the pulse may be viewed in 20 msec segments and paused for review.

NOTE: The pulse is sent to the ECG and Paddle outputs at the same time it is being displayed on the screen.

This page intentionally left blank.

CARDIOVERSION TEST

A Cardioversion Test is simply an energy test with special attention being given to the timing. The DA-2006 continuously monitors for the R-wave timing and displays, if possible, the delay between the R-wave and the pulse. In Cardioversion testing, the Defibrillator is set to deliver a pulse based on a specific delay after the R-wave.

WARNING

This section is provided as a guide to familiarize the user with the DA-2006 Series. It is not intended to provide the necessary test sequence for every Defibrillator. The user must consult the manufacturer's manual for each DUT to determine the correct test procedure to follow.

(1) Connect ECG leads to the corresponding universal connector on the DA-2006.

The connectors are marked with both the AHA and International color codes.

(2) Turn on the DA-2006.

(3) The unit will come up in the "High Range Defibrillator" mode. This range is used for normal adult testing.

NOTE: If it is desirable to run a test at 50 Joules or less with a peak voltage of 1000 Volts or less, the unit may be changed to the "Low Range Defibrillator" mode using the  key.

- (4) Select the desired ECG Waveform and Amplitude to be tested from the choices on the ECG WAVEFORM SCREEN.

NOTE: The selected waveform must contain a QRS complex.

- (5) Set the Defibrillator to Synchronized Cardioversion mode.

- (6) Place the Defibrillator Paddles on the DA-2006 contact plates. The APEX is on the right and the STERNUM is on the left.

NOTE: Reversing the paddles will not cause any damage to the unit or error in the energy reading. However, it will cause the polarity of the oscilloscope output and the playback waveform to be inverted.

- (7) Holding the paddles firmly in place, charge the Defibrillator and discharge it into the DA-2006.

WARNING

**Observe all precautions noted by the Defibrillator
Manufacturer when using the Defibrillator.**

(8) The DA-2006 will automatically sense the voltage rise across the internal 50 ohm load and begin taking readings. After the sampling is done (100 ms) the unit will compute and display the results.

- a. The power pulse is available at the oscilloscope output in real time at 200:1 signal attenuation when in low range and 1000:1 signal attenuation when in high range.
- b. After the computation, the pulse is automatically played back at a 200:1 time base expansion (200 times slower) on both the ECG leads and the Paddle plates. The signal level is 1 mV per 1000 Volts on Lead 1.
- c. At the same time, the test results are sent to the printer.

(9) The Status line will change to indicate the various steps as they are being done.

(10) At the end of the process the results are continuously displayed in the Test Results section of the MAIN SCREEN. They will remain there until another test is performed, the range is changed or the power is turned off.

NOTE: Special note should be made of the "Delay: xxx msec" line in the results. This will show the delay between the peak of the R-wave and the start of the Pulse.

The user may repeat the playback of the waveform at any time by changing to the PLAYBACK LAST PULSE SCREEN using the  key. In this screen the pulse may be viewed in 20 msec segments and paused for review.

NOTE: The pulse is sent to the ECG and Paddle outputs at the same time it is being displayed on the screen.

CHARGE TIME TEST

The charging time of a Defibrillator is nothing more than a measurement of the time required for the Defibrillator to charge. It is used to test the battery, charging circuitry and capacitor. The DA-2006 provides a simple way to start and stop the timer. It also records the results.

WARNING

This section is provided as a guide to familiarize the user with the DA-2006 Series. It is not intended to provide the necessary test sequence for every Defibrillator. The user must consult the manufacturer's manual for each DUT to determine the correct test procedure to follow.

- (1) Turn on the DA-2006.
- (2) The unit will come up in the "High Range Defibrillator " mode. This range is used for normal adult testing.
- (3) Set the Defibrillator to its maximum power setting.
- (4) Depress the  key.

- (5) While the Pre-Warning Countdown is running, place the Defibrillator Paddles on the DA-2006 contact plates. The APEX is on the right and the STERNUM is on the left.

NOTE: Reversing the paddles will not cause any damage to the unit or error in the energy reading. However, it will cause the polarity of the oscilloscope output and the playback waveform to be inverted.

- (6) Holding the paddles firmly in place, wait until the Pre-Warning Countdown equals zero and then immediately start charging the Defibrillator.

- (7) As soon as the DUT is fully charged, discharge it into the DA-2006.

<p style="text-align: center;">WARNING</p> <p>Observe all precautions noted by the Defibrillator Manufacturer when using the Defibrillator.</p>

- (8) At the end of the process the results are continuously displayed in the Test Results section of the MAIN SCREEN. They will remain there until another test is performed, the range is changed or the power is turned off.

NOTE: The last line in the Test Results section of the screen will show "Chg Time: xxx.x sec"

SHOCK ADVISORY ALGORITHM TEST

The Shock Advisory Algorithm Test works with the analysis and prompting functions on automatic and semiautomatic Defibrillators. These circuits look at ECG waveforms and prompt the user to “Shock” or “No Shock” based on national and international guidelines. The following table outlines these guidelines:

SHOCK ADVISORY ALGORITHM TEST	
ECG SIGNALS	ACTION
Asystole	No Shock
Supra Ventricular Tachycardia @ 90 BPM	No Shock
Polyfocal Ventricular Tachycardia @ 140 BPM	No Shock
Multifocal Ventricular Tachycardia @ 140 BPM	No Shock
Coarse Ventricular Fibrillation	Shock
Fine Ventricular Fibrillation	Shock
Polyfocal Ventricular Tachycardia @ 160 BPM	Shock
Multifocal Ventricular Tachycardia @ 160 BPM	Shock

WARNING

This section is provided as a guide to familiarize the user with the DA-2006 Series. It is not intended to provide the necessary test sequence for every Defibrillator. The user must consult the manufacturer’s manual for each DUT to determine the correct test procedure to follow.

- (1) Connect ECG leads to the corresponding universal connector on the DA-2006.
The connectors are marked with both the AHA and International color codes.
- (2) Turn on the DA-2006.
- (3) The unit will come up in the “High Range Defibrillator” mode. This range is used for normal adult testing.
- (4) Select the desired AED Waveform and Amplitude to be tested from the choices on the ECG WAVEFORM SCREEN.
- (5) Set the Defibrillator to analyze the ECG waveform in the automatic or semiautomatic mode.
- (6) Observe and record the response of the Defibrillator to the various waveforms.

TRANSCUTANEOUS PACEMAKER ANALYZER

The DA-2006P can analyze pacemaker pulses as well as determine Refractory periods and Sensitivity levels of on-demand pacemakers. For maximum versatility, the DA-2006P has 26 internally selectable pacemaker loads ranging from 50 ohms to 2300 ohms. The DA-2006P can also test the noise immunity of the DUT by generating a 50 or 60 Hz noise waveform with amplitude up to 100 mV. For sensitivity testing, the DA-2006P can output a Square, Triangle or Haversine waveform with widths ranging from 10ms to 200ms. The input circuitry of the DA-2006P is protected against damage in the case of an accidental defibrillator discharge into the Pacemaker Input terminals.

The  key is used to change to the Pacemaker Analyzer mode.

PACE MAIN SCREEN

The Pacemaker Analyzer MAIN SCREEN shows the current CONFIGURATION, the TEST RESULTS and the available FUNCTION KEYS.

The following is a sample of the PACE MAIN SCREEN:

CONFIGURATION		TEST RESULTS		
Pace : DO NOT DEFIB	Rate :	80 ppm		
Load : 50 ohm	Width :	39.8 mS		
Noise : None	Amp :	18.2 mA		
Wave: 40 mS Square	Energy:	0.6 mJ		
PACE MODE SETUP	SENSITIVITY TEST	REFRACTORY PERIOD TEST	TOGGLE TEST RESULTS	MORE KEYS →

NOTE: The Test Results section of the PACE MAIN SCREEN contains eight lines of data that can be toggled to view the first 4 lines or the second 4 lines (See TEST RESULTS section of manual for more information).

CONFIGURATION

The CONFIGURATION section of the PACE MAIN SCREEN displays the current setup of the unit.

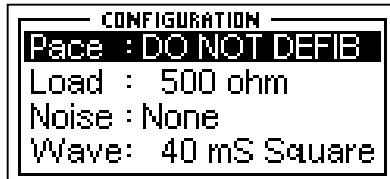

LOAD

This line displays the selected load. This setting may be changed in the PACE MODE SETUP screen. The load choice determines what impedance is used at the pacemaker input as well as whether the unit uses the Pacer Input Terminals or the Defibrillator Plate Input Terminals.

NOISE

This line displays the selected noise output. This setting may be changed in the PACE MODE SETUP screen.

WAVE

This line displays the selected output waveform. This setting may be changed in the PACE MODE SETUP screen. The selected waveform is the output to the pacer on the ECG Terminals, Pacer Terminals and Defibrillator Plate Terminals.

TEST RESULTS

The TEST RESULTS section of the PACE MAIN SCREEN displays the results of the last test. It will continue to be displayed until the power is turned off or another test is run.

The Test Results section of the PACE MAIN SCREEN contains eight lines of data that can be toggled to view the first 4 lines or the second 4 lines by pressing the  key.

TEST RESULTS	
Rate :	80 ppm
Width :	19.9 mS
Amp :	92.3 mA
Energy:	32.0 mJ

TEST RESULTS	
Sens.Pads :	1.62 mV
Sens.ECG :	0.21 mV
Paced RP :	270 mS
Sensed RP:	97 mS

RATE

This line displays the rate of the pacemaker pulse that is present at the selected load.

WIDTH

This line displays the width of the pacemaker pulse that is present at the selected load.

AMP

This line displays the current of the pacemaker pulse that is present at the selected load.

ENERGY

This line displays the energy of the pacemaker pulse that is present at the selected load.

SENS PADS

This line displays the sensitivity at the pads for the selected waveform during the last Sensitivity Test.

SENS ECG

This line displays the sensitivity at the ECG leads for the selected waveform during the last Sensitivity Test.

PACED RP

This line displays the paced refractory period detected at the selected load during the last Refractory Period Test.

SENSED RP

This line displays the sensed refractory period detected at the selected load during the last Refractory Period Test.

FUNCTION KEYS

The FUNCTION KEYS section of the PACE MAIN SCREEN displays the current functions of the keys found below the display. These keys allow for navigation to supporting screens and initiation of specific features.

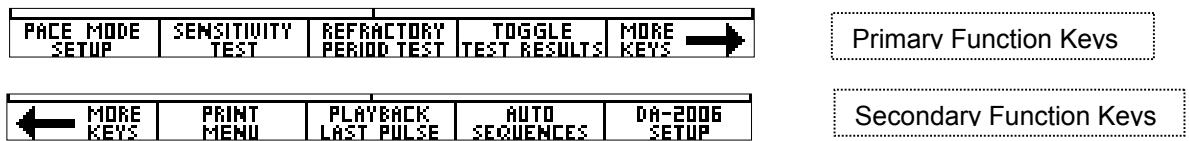

PACE MODE SETUP

This key enters the PACE MODE SETUP SCREEN where all pace parameters are chosen.

SENSITIVITY TEST

This key activates a Sensitivity Test.

REFRACTORY PERIOD TEST

This key activates a Refractory Period Test.

TOGGLE TEST RESULTS

This key toggles the test result section to view the first 4 lines or the second 4 lines of data.

MORE KEYS

These keys toggle between the Primary and Secondary Function Keys.

PRINT MENU

This key enters the PRINT SCREEN that allows the printing of the header or the test data.

PLAYBACK LAST PULSE

This key enters the PLAYBACK LAST PULSE screen where a graphical representation of the last pulse may be viewed and sent out.

AUTO SEQUENCES

This key brings up the AUTO SEQUENCE MENU, which is used to view or run the Auto Sequences stored in the unit.

DA-2006 SETUP



This key brings up the SYSTEM CONFIGURATION SCREEN, which allows for adjusting the various system configuration parameters.

PACER MODE SETUP SCREEN

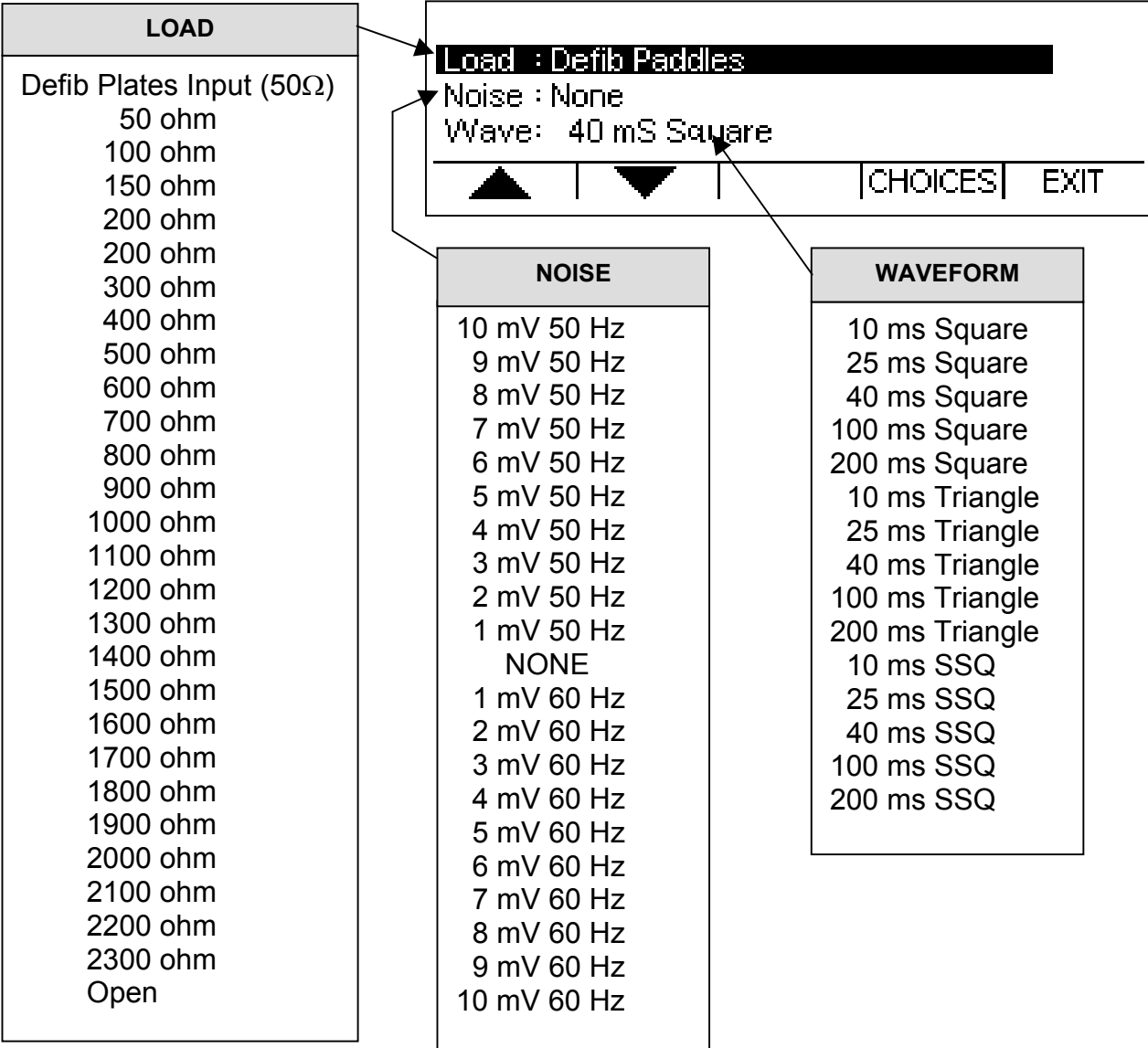

The DA-2006P can be configured to run a large number of tests under various load conditions. This screen is used to configure the unit for these tests. The pacemaker configuration screen is accessed by pressing the PACE MODE
SETUP key from the PACE MAIN SCREEN. In this screen, the user can select the desired Load, the output Noise waveform and the Sensitivity Test waveform.

The following is a sample of the Pacemaker configuration screen:

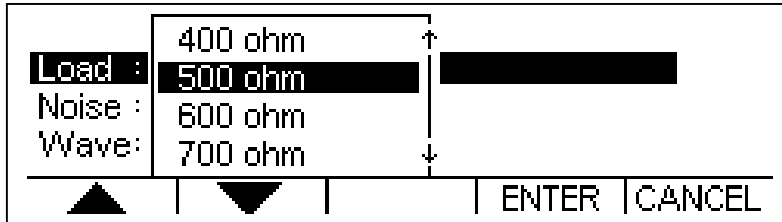

The Load, Noise and Waveform can be selected using  to highlight the parameter and using  to open a drop down menu of all the options for the highlighted parameter.



Use  to scroll to the desired option. Then  is used to accept the new setting. The  key can be used to return to the Pacemaker configuration screen without making a new selection.

The  key is used to return to the PACE MAIN SCREEN.

SENSITIVITY TEST

The Sensitivity Test is used to determine the smallest waveform that the pacemaker can detect. For this test, the selected waveform is generated outside of the refractory period of the pacemaker. The DA-2006P uses a successive approximation approach to determine the smallest output waveform that can be detected by the pacemaker. The Sensitivity Test may be initiated by pressing the SENSITIVITY TEST key from the PACE MAIN SCREEN.

WARNING

This section is provided as a guide to familiarize the user with the DA-2006P. It is not intended to provide the necessary test sequence for every Pacemaker. The user must consult the manufacturer's manual for each DUT to determine the correct test procedure to follow.

While this test is running, the following display will show the progress of the test:

CONFIGURATION	TEST RESULTS
Pace : DC	Sensitivity Test Running 0.00 mV
Load : 50	<div style="border: 1px solid black; width: 100px; height: 15px; margin: 2px;"></div> 0.00 mV
Noise : Nor	Please Wait 0 mS
Wave: 40	Or Press Cancel to Exit 0 mS
	CANCEL

At any time, the CANCEL key can be depressed to stop the test and return to the PACE MAIN SCREEN.

Pacemaker Analyzer

At the end of the test, the display will show the pacemaker amplitude sensitivity at the Pacer Terminals and the ECG Terminals.

CONFIGURATION		TEST RESULTS		
Pace : DO NOT DEFIB		Sens.Pads :	0.71 mV	
Load : 50 ohm		Sens.ECG :	0.09 mV	
Noise : None		Paced RP :	0 mS	
Wave: 40 mS Square		Sensed RP:	0 mS	
PACE MODE SETUP	SENSITIVITY TEST	REFRACTORY PERIOD TEST	TOGGLE TEST RESULTS	MORE KEYS →

REFRACTORY PERIOD TEST

For on-demand pacemakers, the pacemaker should ignore any ECG activity after a pacer pulse for a specific period of time. This time period is known as the Refractory Period. The Paced Refractory Period is the time after the pacemaker pulse that ECG activity is ignored. If an ECG pulse is present inside the refractory period, it is ignored. If an ECG pulse is detected outside of the refractory period, the pacemaker will re-synchronize to the sensed ECG pulse. For each sensed ECG pulse, there is a second refractory period. This is known as the Sensed Refractory Period. It is the period of time after the sensed ECG pulse that ECG activity is ignored. The Refractory Period Test may be initiated by pressing the REFRACTORY PERIOD TEST key from the PACE MAIN SCREEN.

WARNING

This section is provided as a guide to familiarize the user with the DA-2006P. It is not intended to provide the necessary test sequence for every Pacemaker. The user must consult the manufacturer's manual for each DUT to determine the correct test procedure to follow.

While the Refractory Period test is running, the display will indicate the progress of the test:

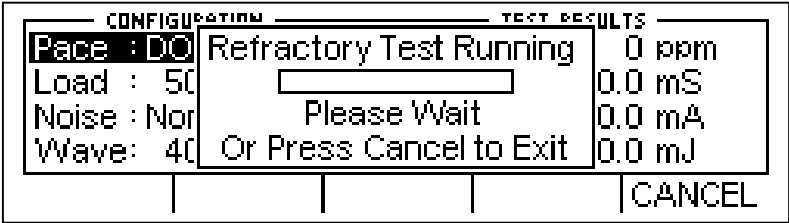

NOTE: It is important that the pulse rate does not change for the duration of the Refractory Test.

Pacemaker Analyzer

At any time, the CANCEL key can be depressed to stop the test and return to the PACE MAIN SCREEN.

When the test is completed, the display will update with the Paced Refractory Period and Sensed Refractory Period in the Test Results.

CONFIGURATION		TEST RESULTS		
Pace : DO NOT DEFIB	Load : 50 ohm	Sens.Pads :	0.71 mV	
Noise : None	Wave : 40 mS Square	Sens.ECG :	0.09 mV	
		Paced RP :	245 mS	
		Sensed RP :	200 mS	
PACE MODE SETUP	SENSITIVITY TEST	REFRACTORY PERIOD TEST	TOGGLE TEST RESULTS	MORE KEYS →

PRINT MENU SCREEN

The DA-2006P allows the user to print the latest Pacemaker Analysis data or a header. The PRINT MENU SCREEN is accessed by pressing the **PRINT MENU** key from the PACE MAIN SCREEN.

The following is an example of the print menu screen:

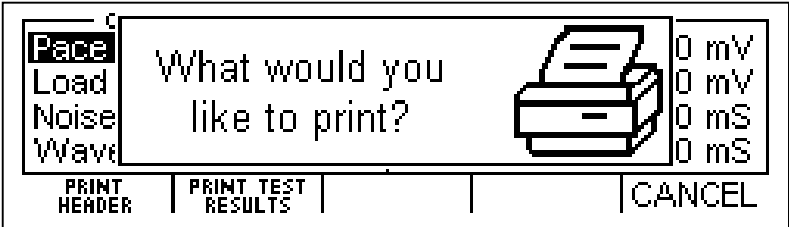

The header is sent by pressing the **PRINT HEADER** key.

The test data is sent by pressing the **PRINT TEST RESULTS** key.

The **CANCEL** key can be depressed to return to the PACE MAIN SCREEN.

PLAYBACK LAST PULSE SCREEN

The DA-2006P can display a graphical representation of the last pulse. This screen may be accessed by pressing the **PLAYBACK LAST PULSE** key from the PACE MAIN SCREEN. The playback allows the user to view the Pacemaker pulse in a time-expanded form. Samples are stored internally at 0.1 ms intervals. The PLAYBACK LAST PULSE SCREEN shows these samples expanded by a time factor of 200.

In playback mode, the samples are shown on the display and sent out the ECG leads, Defibrillator Plates, and the High Level output. The following is a sample of the waveform that is shown in the display:

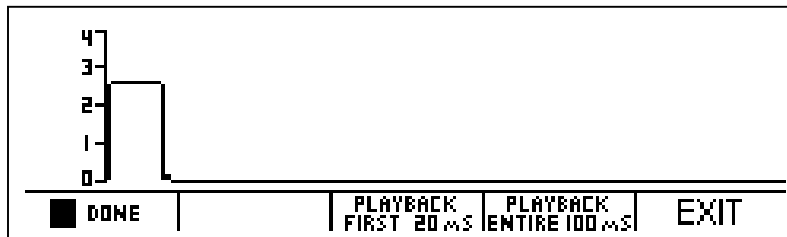



The scale shown on the screen is automatically adjusted to provide the maximum resolution available.

The **PAUSE** key can be used to pause the screen at any point while a pulse is being played back. This key replaces the **DONE** key when a pulse is being played back.

The **PLAY** key can be used to play (continue) the waveform if it has been paused. This key replaces the **PAUSE** key.

Pacemaker Analyzer

The  key starts a playback of only the first 20 ms of the waveform.

The  key starts a playback of the entire 100 ms of the waveform.

At any time, the  key or  key can be depressed to return to the MAIN SCREEN.

MESSAGES

INPUT OVERLOAD

The “Warning Input Overload Check Range” message can display during Defibrillator testing. The range should be checked to see if it should be changed to High Range for the current Joule setting.

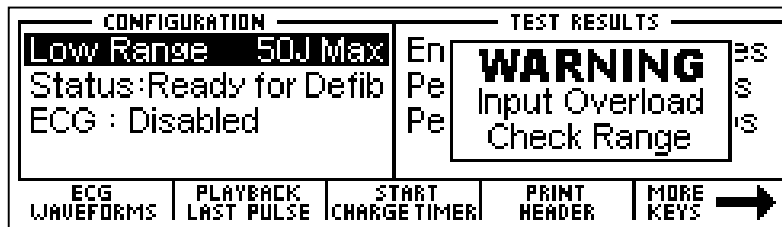

NO PULSE (DA-2006P Only)

The “Test Cancelled No Pulse for 3 seconds” message can display during Refractory or Sensitivity Pacer testing. The settings should be checked and the test rerun.

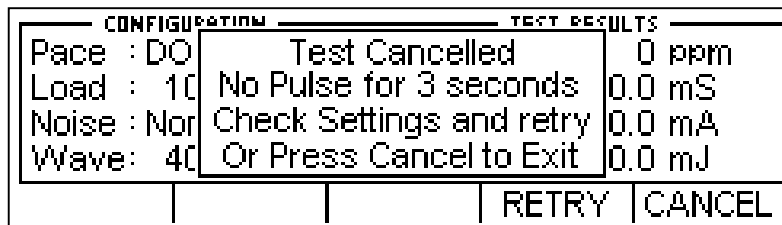

SENSITIVITY TOO HIGH (DA-2006P Only)

The “Test Cancelled DUT Sensitivity too high” message can display during Pacer testing. This happens when the Pacemaker does not detect the pulse generated by the DA-2006P. It could be that it is connected improperly or set to Async mode. This can occur during either the Sensitivity or Refractory test modes.

CONFIGURATION		TEST RESULTS	
Pace : 00	Test Cancelled	0 ppm	
Load : 10	DUT Sensitivity too high	0.0 mS	
Noise : Nor	Reduce Sens and retry	0.0 mA	
Wave: 40	Or Press Cancel to Exit	0.0 mJ	
			RETRY CANCEL

LOW BATTERY

This message indicates that the batteries are low and should be replaced.





CONFIGURATION		TEST RESULTS	
High Range	LOW BATTERY 7% Life Remaining	0.0 Joules	
Status: Pleas		0.0 Volts	
ECG : Disabl		0.0 Amps	
ECG WAVEFORMS	PLAYBACK LAST PULSE	START CHARGE TIMER	PRINT HEADER MORE KEYS →

EXITING AUTO SEQUENCE TESTING

The “Exit Auto Sequence Test All Data Will be Lost!” message will display in the Auto Sequencing Mode when is pushed. If the data is needed, it should be printed prior to exiting.

		TEST RESULTS	
LifePak 8P	Exit AutoSequence Test	0 ppm	
Set Pacem	All Data Will be Lost!	0.0 mS	
Press Star	Are You Sure?	0.0 mA	
PaceRP:		0.0 mJ	
			YES NO

SYSTEM SETUP

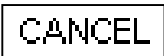
The SYSTEM SETUP SCREEN allows for the configuration of the system settings. The settings can be selected using  to highlight the parameter and using  to allow the editing of the parameter. The  keys are used to edit the setting, then  is used to accept the new setting. The  key can be used to return to the configuration screen without making a new selection.

The  key is used to return to the MAIN SCREEN.

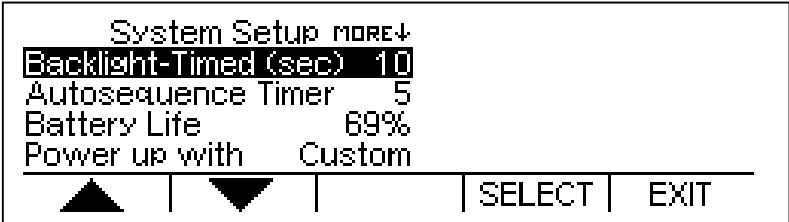

The following is a brief description of the parameters and the available range of settings:

Parameter	Description	Range
Backlight Timed	Off – Always off 1-20 sec – The elapsed time after which the backlight will automatically turn off. Always On – The backlight will be manually controlled by backlight key)	Off, 1-20 sec, Always On
Auto Sequence Timer	Sets the delay between Auto Sequence tests when the test passes.	1-20 sec
Battery Life	Displays current life of the batteries. At 5%, a warning screen will appear. At 10%, the unit will power down automatically.	5-100% (Read Only)
Power up with	Selects the values that will be used when the unit is first turned on. It is also used to Set the Custom Defaults, if used. (See Power Up Settings).	Default/Last/ Custom/ Set Custom Defaults
Software	Displays current software program.	(Read Only)

This page intentionally left blank.

POWER UP SETTINGS

The DA-2006 Series allows the user to tailor the settings that the unit will have on Power Up. The “Power Up With” parameter in the System Setup Menu allows for the selection of either Default or Custom selections.

DEFAULT

If this option is selected the following settings will be used every time the unit is turned on.

Range – Defib, High Range mode

ECG – Output Disabled

Pacemaker Load – 100 ohm

Pacemaker Noise Waveform- None

Pacemaker Output Waveform – 40 ms Square wave.

CUSTOM

If this option is selected, the user may save a unique set of default parameters and the unit will recall them every time the power is turned on.

SET CURRENT AS CUSTOM

The user simply configures the unit to the desired default conditions, selects this option and presses The current configuration is then saved as the Custom Power up values.

This page intentionally left blank.

AUTO SEQUENCE FUNCTION

The DA-2006 Series allows the user run up to 50 pre-programmed sequences of tests (Auto Sequences). The tests are configured with an easy to use PC program. Each test can be configured to test Defibrillator, Transcutaneous Pacemaker or both. (For programming Auto Sequences, see the Auto Sequence Programming section). Once configured, the tests are then downloaded to the DA-2006 unit through the RS232 serial interface.

The AUTO SEQUENCE SCREEN is accessed using the  key.

Use arrows to find Auto Sequence



Sequence Type: Defib and Pacer

4)LifePak 6S	←	
5)LifePak 7		
6)LifePak 8P		
7)LifePak 9P		

▲ | ▼ | VIEW | RUN | EXIT

AUTO SEQUENCES

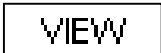
- LifePak 4
- LifePak 5
- LifePak 6
- LifePak 6S
- LifePak 8P
- LifePak 9P
- LifePak 9PM
- LifePak 10
- LifePak 10P
- LifePak 10PM
- HP 78660A
- HP XLPM
- Nihon Kohden 7000
- Laerdal HS 2000
- Marquette 1500PM
- Zoll PD 2000
- Zoll M-Series DSW
- Zoll AED Plus
- Blank Tests 20-50

In this menu, the  keys are used to select the desired test. The  key can be used to enter the VIEW MODE which will allow the user to view the programmed test options of the selected test. The  key will run the selected test and enter the RUN MODE which will step the technician through the programmed test as well as identify whether each step has passed or failed based upon the pre-programmed test limits that are part of each Auto Sequence.

The following table shows the possible test sequence with the details and options that can be selected using the PC program:

Test	Description	Fields	Options
Defibrillator Test Sequence			
Defib Energy Tests	Measures defibrillator discharge energy	Steps	1-20 xxx Joules
		Energy Level Limits	0-99%
		VFIB ECG Output	yes/no
Maximum Energy Test	Measures time required for defibrillator to charge to maximum energy	Do Test?	yes/no
		Energy Level Limits	xxx Joules
		Max Allowed Charge Time	x sec
Cardioversion Tests	Measures Cardioversion Delay	Steps	1-3 xxx Joules
		Energy Level Limits	0-99%
ECG Performance Test	Tests defibrillator ECG input	Steps	Up to 10
		Waveform Outputs and Amplitudes	x Waveform Group x Waveform Lead II = x.x mV
Pacemaker Test Sequence (DA-2006P Only)			
Pulse Rate and Amplitude Tests	Measures Pacemaker Pulse Rate and Amplitude	Steps	1-20
		Pulse Rate, Pulse Amplitude and Load settings	xxx ppm xx mA xxx ohms
		Limits for Rate and Amplitude	0-99%
Asynchronous Test	Tests Pacemaker Asynchronous Mode	Do Test?	yes/no
		Pulse Rate and Load	xxx ppm xxx ohms
Demand Mode Tests	Measures Pacemaker Sensitivity at Pacemaker Pads and ECG leads	Steps	1-5
		Pulse Rate, Load and Output Waveform	xxx ppm xxx ohms x Waveform
		Do Test?	yes/no
Refractory Test	Measures Paced Refractory Period and Sensed Refractory Period	Do Test?	yes/no

VIEW MODE

The VIEW MODE allows the user to look at the test configuration. Each test setting will be shown, as well as the test limits that identify a valid or invalid test result. The screens that are displayed in the VIEW MODE are determined by the Auto Sequence selected on the AUTO SEQUENCE SCREEN and its configuration as defined with the PC program.

The following screens are examples of what could be shown in the VIEW MODE if all test options are selected:

NOTE: If any particular test option is disabled using the PC Program, it will not be shown in the VIEW MODE.

DEFIBRILLATOR ENERGY TESTS:

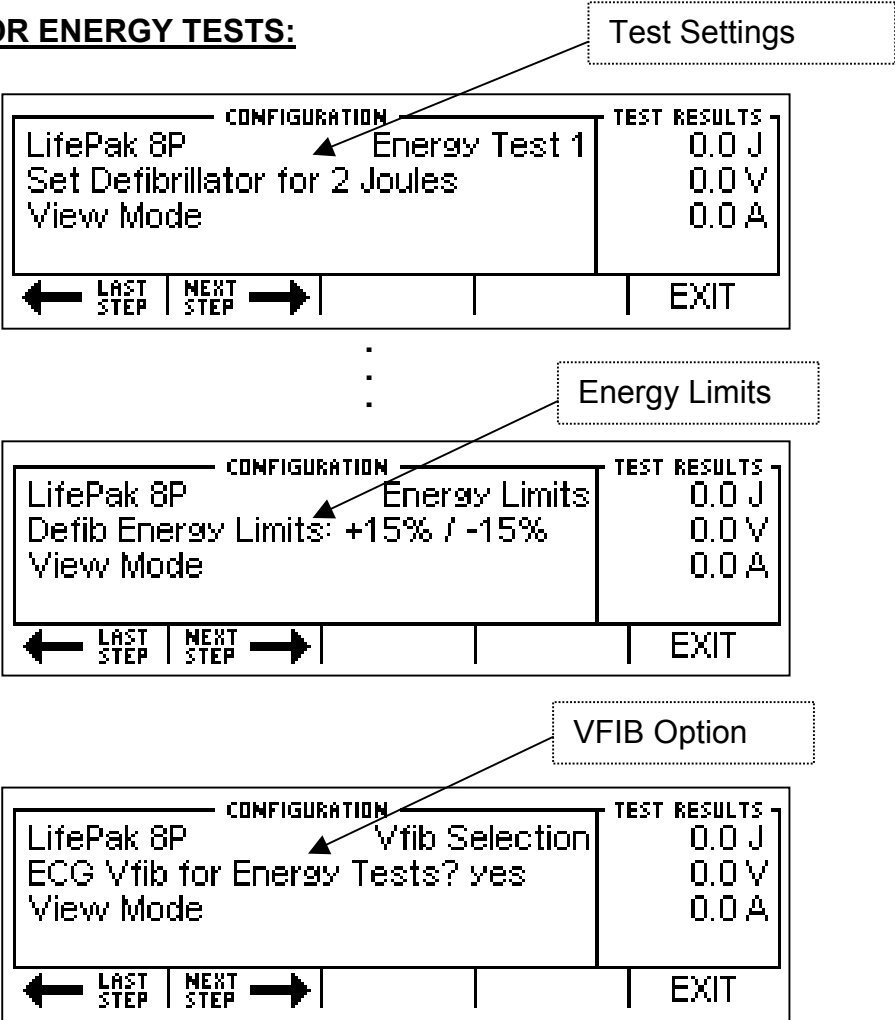

DEFIBRILLATOR MAXIMUM ENERGY TESTS:

Max Energy

CONFIGURATION	TEST RESULTS
LifePak 8P	MaxE Chg Time
Set Defibrillator for 360 Joules	0.0 J
View Mode	0.0 V
	0.0 A
	0.0 S
← LAST STEP NEXT STEP →	EXIT

Max Energy Test Limits

CONFIGURATION	TEST RESULTS
LifePak 8P	MaxE Chg Time
Energy Limits: 338 to 382 Joules	0.0 J
View Mode	0.0 V
	0.0 A
	0.0 S
← LAST STEP NEXT STEP →	EXIT

DEFIBRILLATOR CARDIOVERSION TESTS:

Test Settings

CONFIGURATION	TEST RESULTS
LifePak 8P	Crdvrnsn Test 1
Set Defibrillator for 100 Joules	0.0 J
View Mode	0.0 V
	0.0 A
	0 mS
← LAST STEP NEXT STEP →	EXIT

⋮

Test Limits

CONFIGURATION	TEST RESULTS
LifePak 8P	Crdvrnsn Limits
Cardioversion Limit +12% / -12%	0.0 J
View Mode	0.0 V
	0.0 A
	0 mS
← LAST STEP NEXT STEP →	EXIT

DEFIBRILLATOR ECG PERFORMANCE TEST:

CONFIGURATION		TEST RESULTS
LifePak 8P	ECG Perf 1	
ECG Performance Waveforms? yes		
View Mode		
← LAST STEP	NEXT STEP →	EXIT

Waveform Selection

NOTE: The individual selected waveforms are not displayed in the VIEW MODE.

PACEMAKER PULSE AND AMPLITUDE TESTS: (DA-2006P Only)

CONFIGURATION		TEST RESULTS
LifePak 8P	Pacer Test 1	0 ppm
Set Pacemaker for 40ppm 200mA		0.0 mA
View Mode		Load: 50 Ω
← LAST STEP	NEXT STEP →	EXIT

Test Settings

⋮

CONFIGURATION		TEST RESULTS
LifePak 8P	Pacer Limits	0 ppm
Pacer Rate +/-10% Amp +/-10%		0.0 mA
View Mode		Load: 50 Ω
← LAST STEP	NEXT STEP →	EXIT

Test Limits

PACEMAKER ASYNCHRONOUS MODE TEST: (DA-2006P Only)

CONFIGURATION		TEST RESULTS
LifePak 8P	Pacer Async	0 ppm
Set Pacer to Async Mode 70ppm		0.0 mA
View Mode		Load: 50 Ω
← LAST STEP	NEXT STEP →	EXIT

Pulse Rate Setting

PACEMAKER DEMAND MODE TESTS: (DA-2006P Only)

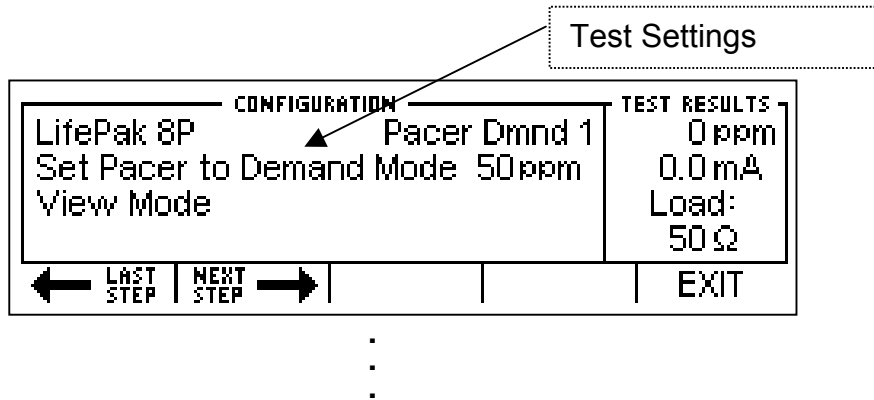

PACEMAKER REFRACTORY TEST: (DA-2006P Only)

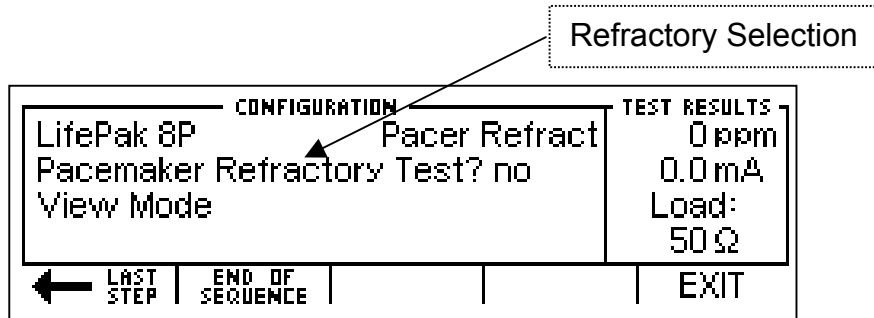

RUN MODE

The RUN MODE allows the user to run the test configuration. The screens that are displayed in the RUN MODE are determined by the Auto Sequence selected on the AUTO SEQUENCE SCREEN and its configuration as defined with the PC program.

Running an Auto Sequence will provide a consistent, guided procedure for testing equipment. This is a semi-automated process that will provide immediate feedback to the user if the DUT passes or fails individual tests. A programmable timer is provided to automatically progress through the test when a given test passes. This timer is set in the Auto Sequence Timer parameter in the SYSTEM SETUP SCREEN.

NOTE: If any particular test option is disabled using the PC Program, it will not be shown in the RUN MODE.

NOTE: Some tests, like Performance Waveforms, do not have quantitative analyses and therefore require the user to manually progress through the test.

The following sample screen shows the common elements present during the RUN MODE:

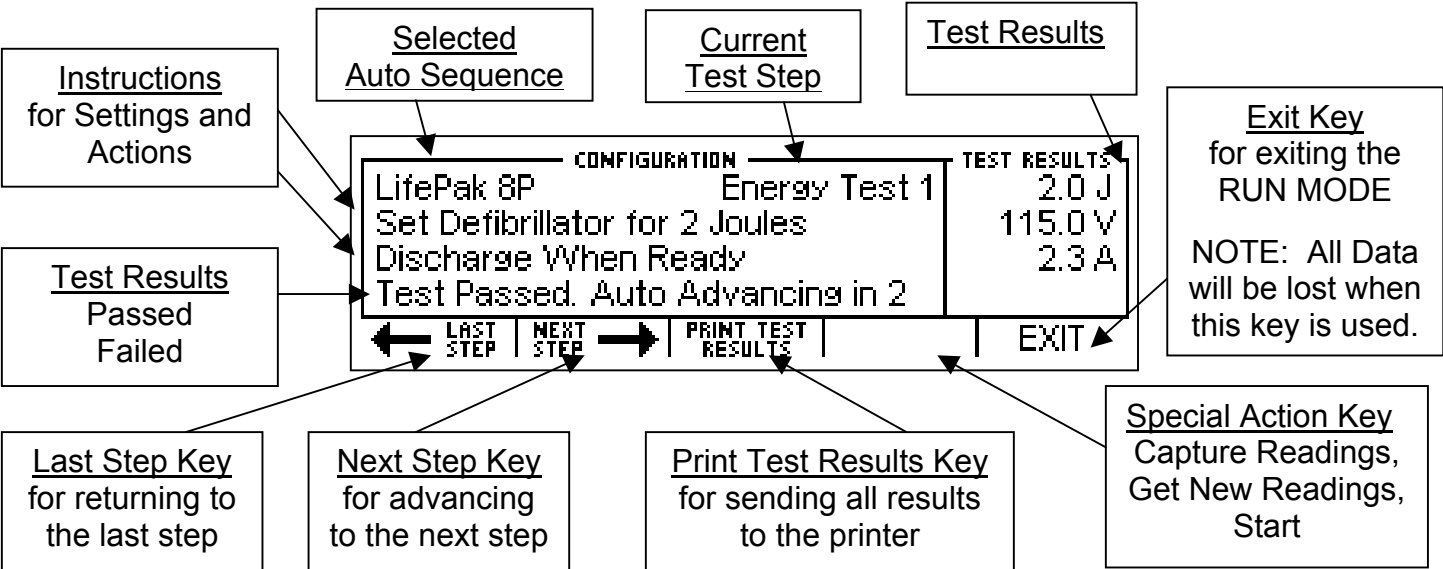

The following screens may be shown in the RUN MODE if all test options are selected:

DEFIBRILLATOR ENERGY TESTS:

Test Setup and Action

CONFIGURATION		TEST RESULTS
LifePak 8P	Energy Test 1	0.0 J
Set Defibrillator for 2 Joules		0.0 V
Discharge When Ready		0.0 A

← LAST STEP | NEXT STEP → | PRINT TEST RESULTS | EXIT

Test Passed

CONFIGURATION		TEST RESULTS
LifePak 8P	Energy Test 1	2.0 J
Set Defibrillator for 2 Joules		115.0 V
Discharge When Ready		2.3 A
Test Passed. Auto Advancing in 2		

← LAST STEP | NEXT STEP → | PRINT TEST RESULTS | EXIT

Test Failed

CONFIGURATION		TEST RESULTS
LifePak 8P	Energy Test 1	5.1 J
Set Defibrillator for 2 Joules		183.0 V
Discharge When Ready		3.7 A
Test Failed. Retry if desired		

← LAST STEP | NEXT STEP → | PRINT TEST RESULTS | EXIT

DEFIBRILLATOR MAXIMUM ENERGY TESTS:

Test Setup and Action

CONFIGURATION		TEST RESULTS
LifePak 8P	MaxE Chg Time	0.0 J
Set Defibrillator for 360 Joules		0.0 V
Press Start Timer When Ready		0.0 A
		0.0 S
← LAST STEP	NEXT STEP →	PRINT TEST RESULTS
		START CHARGE TIMER
		EXIT

Charge Timer Warning

CONFIGURATION		TEST RESULTS
LifePak 8P	Charge Timer Will Begin in	0.0 J
Set Defibri	4 Seconds	0.0 V
Press Star	Or Press Cancel to Exit	0.0 A
		0.0 S
		CANCEL

Charge Timer Running

CONFIGURATION		TEST RESULTS
LifePak 8P	Charge Timer Running	337.5 J
Set Defibri	4.5 Seconds	2470.0 V
Press Star	Defib When Charged	49.4 A
Test Failed		21.6 S
		CANCEL

Results

CONFIGURATION		TEST RESULTS
LifePak 8P	MaxE Chg Time	338.7 J
Set Defibrillator for 360 Joules		2477.5 V
Press Start Timer When Ready		49.6 A
Test Passed. Auto Advancing in 3		8.8 S
← LAST STEP	NEXT STEP →	PRINT TEST RESULTS
		START CHARGE TIMER
		EXIT

DEFIBRILLATOR CARADIOVERSION TESTS:

Test Setup and Action

CONFIGURATION		TEST RESULTS
LifePak 8P	Crdrvsn Test 1	0.0 J
Set Defibrillator for 100 Joules		0.0 V
Discharge Sync Mode When Ready		0.0 A
		0 mS
← LAST STEP	NEXT STEP →	PRINT TEST RESULTS
		EXIT

Test Passed

CONFIGURATION		TEST RESULTS
LifePak 8P	Crdrvsn Test 1	98.1 J
Set Defibrillator for 100 Joules		1340.0 V
Discharge Sync Mode When Ready		26.8 A
Test Passed. Auto Advancing in 3		26 mS
← LAST STEP	NEXT STEP →	PRINT TEST RESULTS
		EXIT

DEFIBRILLATOR ECG PERFORMANCE TEST:

Waveform

CONFIGURATION		TEST RESULTS
LifePak 8P	ECG Perf 3	Check ECG
ECG: Performance Waveforms		On Defib
Triangle Wave 2 Hz		Then Press
Lead I 0.70mV Lead II 1.0mV		Next Step
← LAST STEP	NEXT STEP →	PRINT TEST RESULTS
		EXIT

NOTE: Some tests, like Performance Waveforms, do not have quantitative analyses and therefore require the user to manually progress through the test.

PACEMAKER PULSE AND AMPLITUDE TESTS: (DA-2006P)

Test Setup and Action

CONFIGURATION		TEST RESULTS
LifePak 8P	Pacer Test 1	41 ppm
Set Pacemaker for 40ppm 20mA		21.1 mA
Press Capture to Test Readings		Load: 50 Ω
← LAST STEP	NEXT STEP →	PRINT TEST RESULTS
		CAPTURE READINGS
		EXIT

Results

CONFIGURATION		TEST RESULTS
LifePak 8P	Pacer Test 1	41 ppm
Set Pacemaker for 40ppm 20mA		21.1 mA
Showing Captured Readings		Load: 50 Ω
Test Passed. Auto Advancing in 2		
← LAST STEP	NEXT STEP →	PRINT TEST RESULTS
		GET NEW READINGS
		EXIT

NOTE: If the test fails or new readings are desired, the Get New Readings Key can be used to replace the current readings. The current readings will be lost, even if they are from a test that passed.

PACEMAKER ASYNCHRONOUS MODE TEST: (DA-2006P Only)

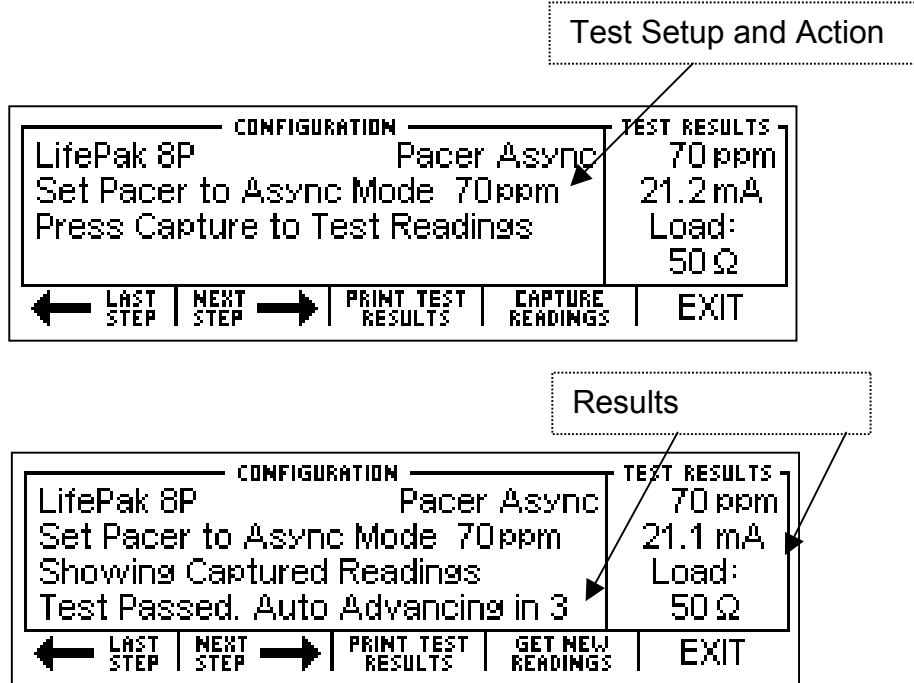

NOTE: If the test fails or new readings are desired, the Get New Readings Key can be used to replace the current readings. The current readings will be lost, even if they are from a test that passed.

PACEMAKER DEMAND MODE TESTS: (DA-2006P Only)

Test Setup and Action

CONFIGURATION		TEST RESULTS
LifePak 8P	Pacer Dmnd 1	51 ppm
Set Pacer to Demand Mode	50ppm	10.3 mA
Press Start for Sensitivity test		Load:
Sens.Pads: 0.00 mV	ECG: 0.00 mV	50 Ω
← LAST STEP	NEXT STEP →	PRINT TEST RESULTS
		START
		EXIT

Sensitivity Test Running

CONFIGURATION		TEST RESULTS
LifePak 8P	Sensitivity Test Running	51 ppm
Set Pacer	<input type="checkbox"/>	10.5 mA
Press Star	Please Wait	Load:
Sens.Pads	Or Press Cancel to Exit	50 Ω
		CANCEL

Results

CONFIGURATION		TEST RESULTS
LifePak 8P	Pacer Dmnd 1	51 ppm
Set Pacer to Demand Mode	50ppm	10.5 mA
Showing Captured Readings		Load:
Sens.Pads: 4.86 mV	ECG: 0.65 mV	50 Ω
← LAST STEP	NEXT STEP →	PRINT TEST RESULTS
		GET NEW READINGS
		EXIT

NOTE: If the test fails or new readings are desired, the Get New Readings Key can be used to replace the current readings. The current readings will be lost, even if they are from a test that passed.

PACEMAKER REFRACTORY TEST: (DA-2006P Only)

Test Setup and Action

CONFIGURATION		TEST RESULTS
LifePak 8P	Pacer Refract	51 ppm
Set Pacemaker to Demand Mode		10.5 mA
Press Start for Refractory test		Load:
PaceRP: 0 mS	SensRP: 0 mS	50 Ω
← LAST STEP	END OF SEQUENCE	PRINT TEST RESULTS
	START	EXIT

Refractory Test Running

CONFIGURATION		TEST RESULTS
LifePak 8P	Refractory Test Running	51 ppm
Set Pacem		10.1 mA
Press Star	Please Wait	Load:
PaceRP:	Or Press Cancel to Exit	50 Ω
		CANCEL

Results

CONFIGURATION		TEST RESULTS
LifePak 8P	Pacer Refract	51 ppm
Set Pacemaker to Demand Mode		10.1 mA
Showing Captured Readings		Load:
PaceRP: 284 mS	SensRP: 290 mS	50 Ω
← LAST STEP	END OF SEQUENCE	PRINT TEST RESULTS
	GET NEW READINGS	EXIT

NOTE: If the test fails or new readings are desired, the Get New Readings Key can be used to replace the current readings. The current readings will be lost, even if they are from a test that passed.

EXITING AUTO SEQUENCE TESTING MESSAGE

The “Exit Auto Sequence Test All Data Will be Lost!” message will display in the Auto Sequencing Mode when is pushed. If the data is needed, it should be printed prior to exiting.

LifePak 8P	Exit AutoSequence Test	TEST RESULTS
Set Pacerr	All Data Will be Lost!	0 ppm
Press Star	Are You Sure?	0.0 mS
PaceRP:		0.0 mA
		0.0 mJ
		YES NO

This page intentionally left blank.

PROGRAMMING AUTO SEQUENCES

Auto Sequences are programmed with an easy to use PC interface. This section shows how to use the Auto Sequence configuration software.

NOTE: In the Auto Sequence PC interface, the DA-2006 Series is noted as DA-2006/P.

SPLASH SCREEN

The Splash Screen identifies the version of the program. This screen will be displayed for 5 seconds, or until the user presses a key or clicks the screen with the mouse.

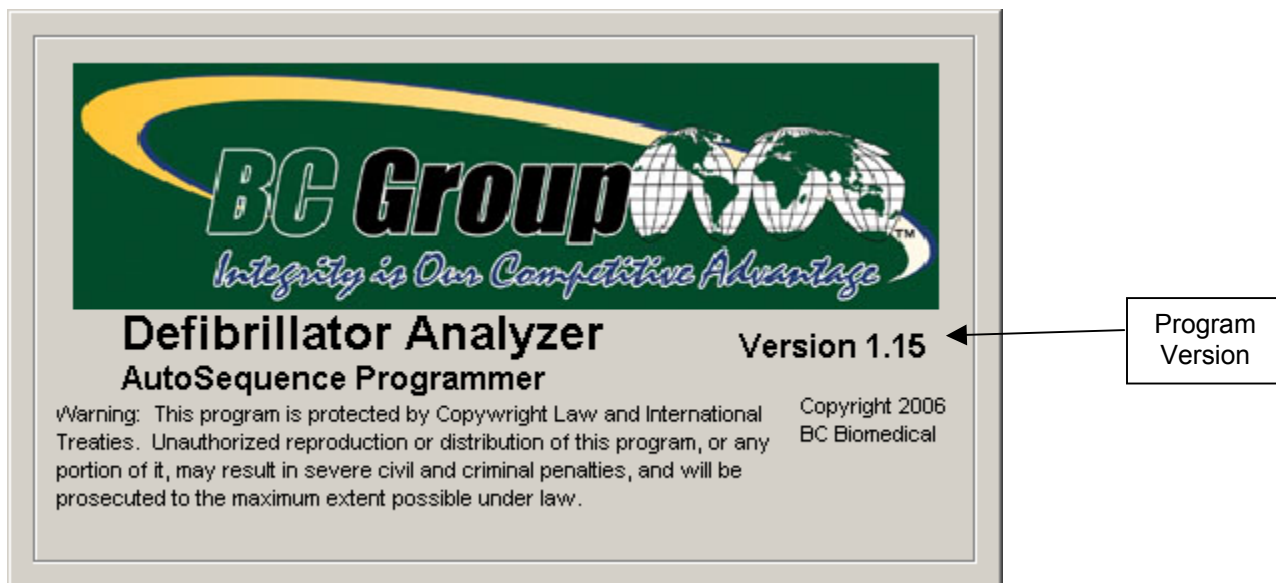

OVERVIEW

The following is a general overview of the PC Interface used for Programming Auto Sequences. Each part of this screen is described in full detail later in this section.

Program Menu Bar
File Help

File Control
This section is utilized to load/save configuration files on the PC as well as read/write the auto configuration in the DA-2006/P

ECG Sequence Programming
Use this section to easily configure each step of the ECG Auto Sequence

Sequence Selection
Use this list to select which sequence to view /edit.

Status Message

AutoSequence Filename
C:\Program Files\BC Biomedical\DA-2006 Series AutoSequence Programmer\Testing AutoSequence.s

Open AutoSequence File Save AutoSequence to File Read AutoSequence from DA-2006/P Download AutoSequence to DA-2006/P

Select Sequence to Edit

- LifePak 4
- LifePak 5
- LifePak 6
- LifePak 6S
- LifePak 7
- LifePak 8P
- LifePak 9P
- LifePak 9PM
- LifePak 10
- LifePak 10P
- LifePak 10PM
- HP 73650A
- HP XLPM
- Nihon Kohden 7000
- Laerdal HS 2000
- Marquette 1500PM
- Zoll PD2000
- Zoll M-Series DSW
- Zoll AED Plus
- Blank Test 20
- Blank Test 21
- Blank Test 22
- Blank Test 23
- Blank Test 24
- Blank Test 25
- Blank Test 26
- Blank Test 27
- Blank Test 28
- Blank Test 29
- Blank Test 30
- Blank Test 31
- Blank Test 32
- Blank Test 33
- Blank Test 34
- Blank Test 35
- Blank Test 36
- Blank Test 37
- Blank Test 38
- Blank Test 39
- Blank Test 40
- Blank Test 41
- Blank Test 42
- Blank Test 43
- Blank Test 44
- Blank Test 45

Edit Sequence Name (20 chars max)
LifePak 4 Copy Sequence

Select Test Mode
 Defibrillator Only
 Pacer Only
 Defib & Pacer

Configure Defibrillator Test Configure Pacer Test

Step	Energy Level Test (0 J to End)	Unit
Step 1	10	Joules
Step 2	25	Joules
Step 3	50	Joules
Step 4	100	Joules
Step 5	200	Joules
Step 6	300	Joules
Step 7	400	Joules
Step 8	450	Joules
Step 9	0	Joules
Step 10	0	Joules
Step 11	0	Joules
Step 12	0	Joules
Step 13	0	Joules
Step 14	0	Joules
Step 15	0	Joules
Step 16	0	Joules
Step 17	0	Joules
Step 18	0	Joules
Step 19	0	Joules
Step 20	0	Joules

Insert Step Delete Step

Tolerance + 15% - 15%

V-Fib Output During No

ECG Performance Test Sequence

Step 1
 ECG Output Group: AED
 ECG Output Waveform: Asystole
 ECG Output Amplitude: Lead II = 1.0 mV

Step 2
 ECG Output Group: Performance
 ECG Output Waveform: Square 2 Hz
 ECG Output Amplitude: Lead II = 1.0 mV

Step 3
 ECG Output Group: Performance
 ECG Output Waveform: Triangle 2 Hz
 ECG Output Amplitude: Lead II = 1.0 mV

Step 4
 ECG Output Group: Normal Sinus Rhythm
 ECG Output Waveform: 80 BPM
 ECG Output Amplitude: Lead II = 1.0 mV

Step 5
 ECG Output Group: []

Current Time
2/25/2007 9:39 AM

Com Port being used

Sequence Configuration
Use this section to configure each Auto Sequence test.

Task Progress Indicator

Today's Date

PROGRAM MENU

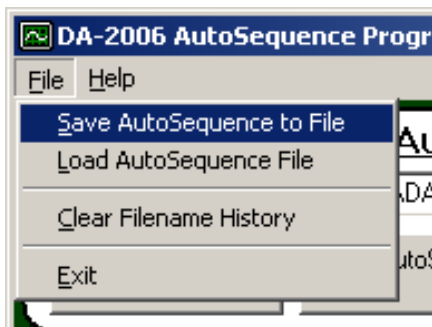

The program menu contains shortcuts to file operations as well as program version information.

From the File Menu, you can Save or Load Auto Sequences as well as Clear the History of files that were used. You can also Exit the program from this menu.



The Help Menu provides access to program version information, shown below:

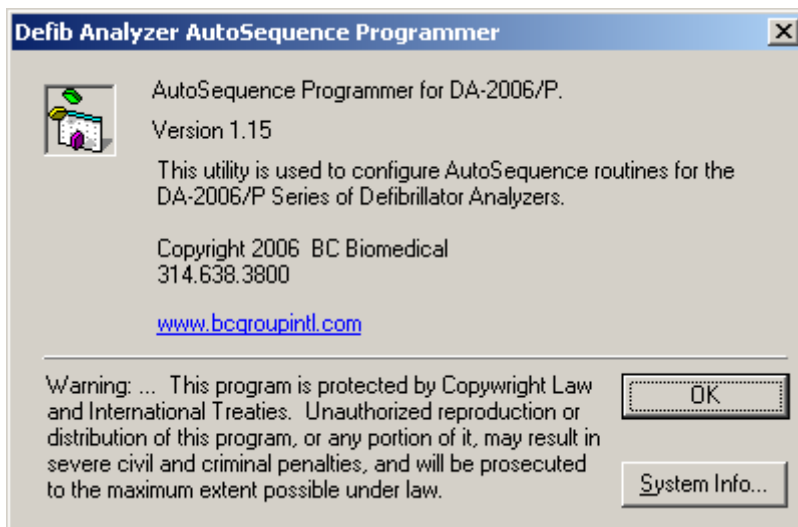

FILE CONTROL

The file control section allows the user to Load and Save Auto Sequence files, greatly expanding the number of pre-programmed sequences from 50 to virtually unlimited. The user also uses the File Control section to Load and Store Auto Sequences on the DA-2006/P.

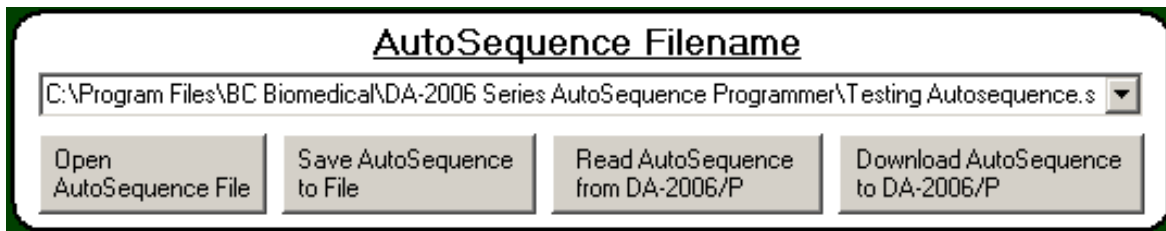

Dropdown List – This list shows the history of files that have recently been used. This provides quick access for switching between common Auto Sequence files.

Open Auto Sequence File – This button brings up the standard Windows Open File dialog box. It is used to load an existing configuration file.

Save Auto Sequence to File – This button brings up the standard Windows Save File dialog box. It is used to save the current configuration to a file for future reference.

Read Auto Sequence from DA-2006/P – This button is used to load the configuration currently stored in the DA-2006/P.

Download Auto Sequence to DA-2006/P – This button is used to send the configured Auto Sequence to the DA-2006/P, where it is stored in non-volatile flash memory.

SEQUENCE SELECTION

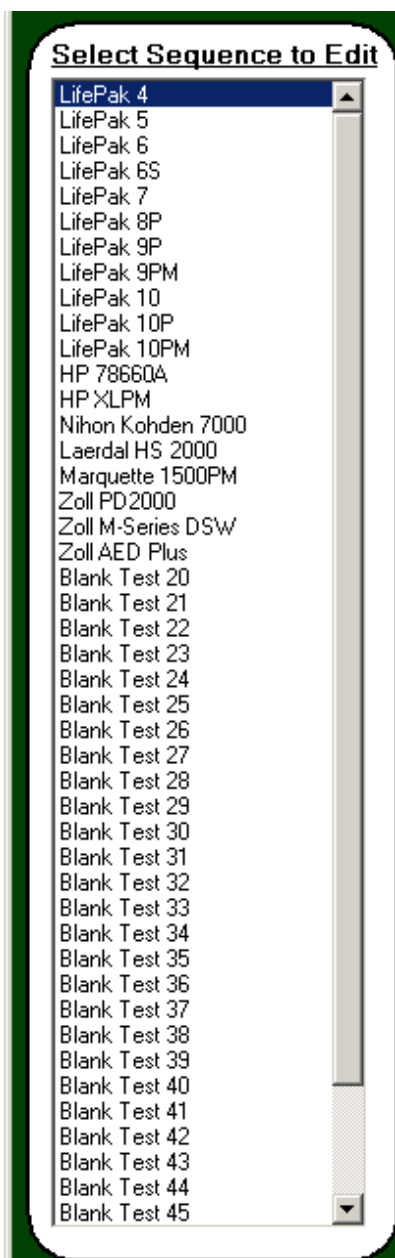

This section shows a list of all of the names of the Auto Sequences. It is used to select an individual sequence for configuration. Once selected, the configuration window will change to display the settings for the selected sequence.

SEQUENCE CONFIGURATION

The sequence configuration window displays all of the configuration settings for each Auto Sequence. This sample screen shows a defib test configuration.

The screenshot shows the 'Sequence Configuration' window for a defibrillator test. At the top, there is a text field for 'Edit Sequence Name (20 chars max)' containing 'LifePak 4' and a 'Copy Sequence' button. Below this are radio buttons for 'Select Test Mode': 'Defibrillator Only' (selected), 'Pacer Only', and 'Defib & Pacer'. Two buttons, 'Configure Defibrillator Test' and 'Configure Pacer Test', are visible. The main area is titled 'Energy Level Test (0 J to End)' and contains a list of 20 steps, each with a numerical value in a text box and 'Joules' to its right. Below the list are 'Insert Step' and 'Delete Step' buttons. Further down are 'Tolerance' settings (+15% and -15%), a 'V-Fib Output During Level Test?' dropdown set to 'No', and three sections: 'Max Energy Test' with fields for 'Do Max Energy Test?', 'Max Energy', 'High Limit', 'Low Limit', and 'Max Charge Time'; 'Cardioversion Test' with fields for 'Do Cardioversion Test?', three step energy values, 'Energy Limit', and 'Delay Limit'; and 'ECG Performance Test' with a 'Do Performance Test?' dropdown.

Sequence Name – This name can be any string of up to 20 standard ASCII characters. NOTE: Not all ASCII characters are valid and will be ignored.

Copy Sequence Button – This button opens the Copy Sequence Screen that allows the user to quickly configure similar test sequences.

Test Mode Selections – These selections allow each test to be configured as a Defibrillator Only, a Pacer Only or a Defib & Pacer test.

Configure Test Buttons – These buttons are used to alternate between defib and pacer test configuration windows.

Defibrillator Test Details – Each of the potential tests and test details for the Defibrillator are displayed for configuration. For ease of programming, individual steps can be deleted or added and individual tests can be included or not included.

Insert and Delete Steps Buttons – These buttons will open the Insert Steps Screen or the Delete Steps Screen.

Edit Sequence Name (20 chars max)
 LifePak 9PM Copy Sequence

Select Test Mode
 Defibrillator Only Pacer Only Defib & Pacer

Configure Defibrillator Test Configure Pacer Test

Pulse Mode Tests (0 ppm to End)

Step	Rate (ppm)	Amplitude (mA)	Load (Ohms)	Mode
Step 1	60	55	700	Ohms
Step 2	150	55	700	Ohms
Step 3	170	55	700	Ohms
Step 4	160	55	700	Ohms
Step 5	140	55	700	Ohms
Step 6	130	55	700	Ohms
Step 7	120	55	700	Ohms
Step 8	110	55	700	Ohms
Step 9	100	55	700	Ohms
Step 10	90	55	700	Ohms
Step 11	80	55	700	Ohms
Step 12	70	55	700	Ohms
Step 13	60	55	700	Ohms
Step 14	50	55	700	Ohms
Step 15	40	55	700	Ohms
Step 16	60	200	700	Ohms
Step 17	60	150	700	Ohms
Step 18	60	100	700	Ohms
Step 19	60	130	700	Ohms
Step 20	0	0	Defib	Ohms

Insert Step Delete Step

Rate Tol ± 10 % Amp Tol ± 10 %

Async Mode Test
 Do Async Mode Test? Yes
 Rate 60 ppm Load 100 Ohms

Demand Mode Tests (0 ppm to End)
 Do Demand Mode Test? Yes

Step	Rate (ppm)	Amplitude (mA)	Load (Ohms)	Output Waveform
Step 1	50	700	700	40 mS Square
Step 2	0	Defib	700	10 mS Square
Step 3	0	Defib	700	10 mS Square
Step 4	0	Defib	700	10 mS Square
Step 5	0	Defib	700	10 mS Square

Refractory Mode Test
 Do Refractory Mode Test? No

Pacer Test Details – Each of the potential tests and test details for the Pacer are displayed for configuration. For ease of programming, individual steps can be deleted or added and individual tests can be included or not included.

Insert and Delete Steps Buttons – These buttons will open the Insert Steps Screen or the Delete Steps Screen.

Copy Sequence Screen

This function allows the user to quickly configure similar Auto Sequences. Simply select the source and target test sequences, press OK, and the target sequence will be overwritten with the configuration from the source sequence configuration. The Cancel button will exit the window without modifying any configuration settings.

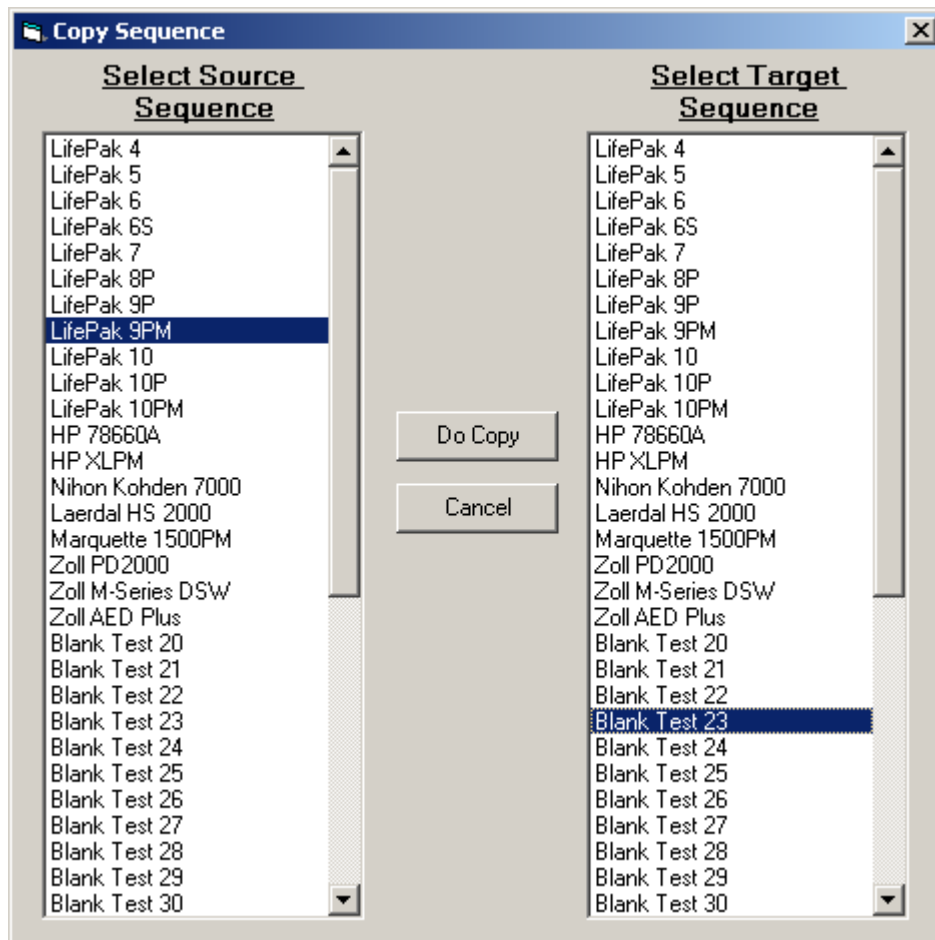

Insert Step and Deleting Step Screens

The insert and delete functions allow the user to quickly modify an existing test configuration. Deleting a step will move all of the tests following the deleted test up by one step and clear the final step. Inserting a step will shift all following steps down by one step and clear the selected step location.

Defibrillator Examples:

Pressing OK here would shift steps 4-19 down by one step and insert a blank step at step 4.

Pressing OK here would shift steps 6-20 up by one step and insert a blank step at step 20.

Programming Auto Sequences

Pacer Examples:

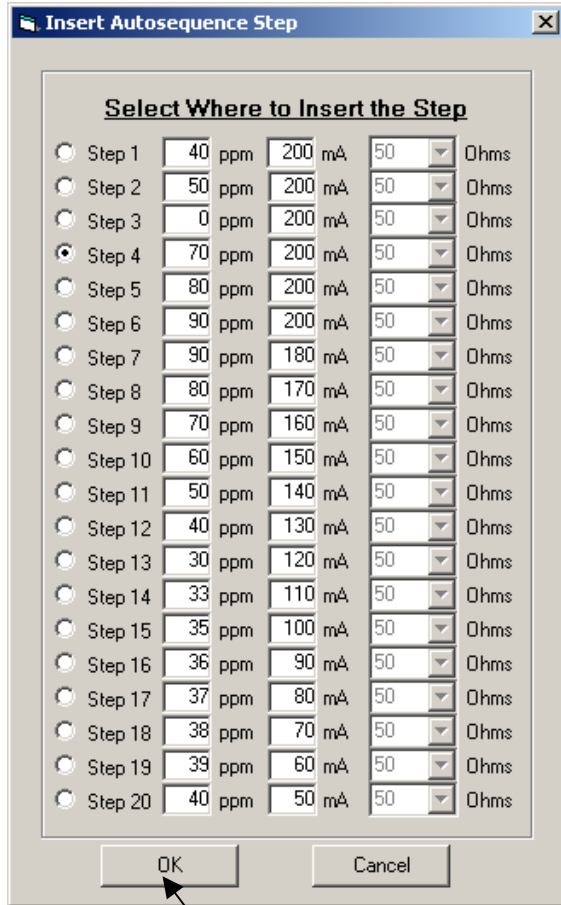

Insert Autosequence Step

Select Where to Insert the Step

<input type="radio"/>	Step 1	40	ppm	200	mA	50	Ohms
<input type="radio"/>	Step 2	50	ppm	200	mA	50	Ohms
<input type="radio"/>	Step 3	0	ppm	200	mA	50	Ohms
<input checked="" type="radio"/>	Step 4	70	ppm	200	mA	50	Ohms
<input type="radio"/>	Step 5	80	ppm	200	mA	50	Ohms
<input type="radio"/>	Step 6	90	ppm	200	mA	50	Ohms
<input type="radio"/>	Step 7	90	ppm	180	mA	50	Ohms
<input type="radio"/>	Step 8	80	ppm	170	mA	50	Ohms
<input type="radio"/>	Step 9	70	ppm	160	mA	50	Ohms
<input type="radio"/>	Step 10	60	ppm	150	mA	50	Ohms
<input type="radio"/>	Step 11	50	ppm	140	mA	50	Ohms
<input type="radio"/>	Step 12	40	ppm	130	mA	50	Ohms
<input type="radio"/>	Step 13	30	ppm	120	mA	50	Ohms
<input type="radio"/>	Step 14	33	ppm	110	mA	50	Ohms
<input type="radio"/>	Step 15	35	ppm	100	mA	50	Ohms
<input type="radio"/>	Step 16	36	ppm	90	mA	50	Ohms
<input type="radio"/>	Step 17	37	ppm	80	mA	50	Ohms
<input type="radio"/>	Step 18	38	ppm	70	mA	50	Ohms
<input type="radio"/>	Step 19	39	ppm	60	mA	50	Ohms
<input type="radio"/>	Step 20	40	ppm	50	mA	50	Ohms

OK Cancel

Pressing OK here would shift steps 4-19 down by one step and insert a blank step at step 4.

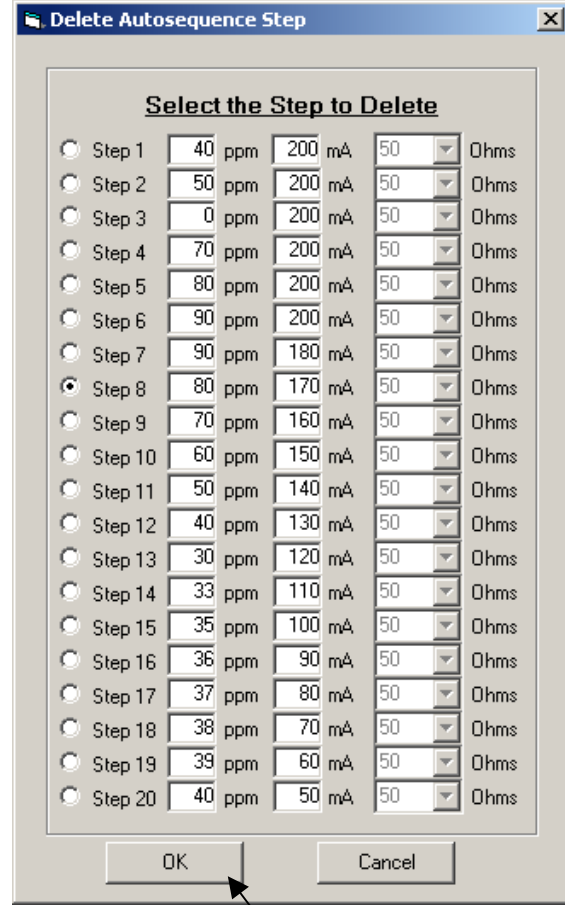

Delete Autosequence Step

Select the Step to Delete

<input type="radio"/>	Step 1	40	ppm	200	mA	50	Ohms
<input type="radio"/>	Step 2	50	ppm	200	mA	50	Ohms
<input type="radio"/>	Step 3	0	ppm	200	mA	50	Ohms
<input type="radio"/>	Step 4	70	ppm	200	mA	50	Ohms
<input type="radio"/>	Step 5	80	ppm	200	mA	50	Ohms
<input type="radio"/>	Step 6	90	ppm	200	mA	50	Ohms
<input type="radio"/>	Step 7	90	ppm	180	mA	50	Ohms
<input checked="" type="radio"/>	Step 8	80	ppm	170	mA	50	Ohms
<input type="radio"/>	Step 9	70	ppm	160	mA	50	Ohms
<input type="radio"/>	Step 10	60	ppm	150	mA	50	Ohms
<input type="radio"/>	Step 11	50	ppm	140	mA	50	Ohms
<input type="radio"/>	Step 12	40	ppm	130	mA	50	Ohms
<input type="radio"/>	Step 13	30	ppm	120	mA	50	Ohms
<input type="radio"/>	Step 14	33	ppm	110	mA	50	Ohms
<input type="radio"/>	Step 15	35	ppm	100	mA	50	Ohms
<input type="radio"/>	Step 16	36	ppm	90	mA	50	Ohms
<input type="radio"/>	Step 17	37	ppm	80	mA	50	Ohms
<input type="radio"/>	Step 18	38	ppm	70	mA	50	Ohms
<input type="radio"/>	Step 19	39	ppm	60	mA	50	Ohms
<input type="radio"/>	Step 20	40	ppm	50	mA	50	Ohms

OK Cancel

Pressing OK here would shift steps 6-20 up by one step and insert a blank step at step 20.

ECG CONFIGURATION SECTION

ECG Performance Test Sequence

Step 1

ECG Output Group
AED

ECG Output Waveform
Asystole

ECG Output Amplitude
Lead II = 1.0 mV

Step 2

ECG Output Group
Performance

ECG Output Waveform
Square 2 Hz

ECG Output Amplitude
Lead II = 1.0 mV

Step 3

ECG Output Group
Performance

ECG Output Waveform
Triangle 2 Hz

ECG Output Amplitude
Lead II = 1.0 mV

Step 4

ECG Output Group
Normal Sinus Rhythm

ECG Output Waveform
80 BPM

ECG Output Amplitude
Lead II = 1.0 mV

Step 5

ECG Output Group

2/25/2007 9:41 AM

This section configures the ECG Performance sequence when the ECG Performance Test option is set to YES for a Defibrillator Test.

The ECG sequence consists of up to 10 steps. Each step consists of a selected waveform group (Disabled, NSR, AED, Arrhythmia or Performance), output waveform and output amplitude.

There is only one ECG sequence for all 50 Auto Sequence tests.

To use less than 10 steps, set the ECG output group of the next step after the last to "Disabled."

This page intentionally left blank.

MANUAL REVISIONS

<u>Revision #</u>	<u>Program #</u>	<u>Revisions Made</u>
Rev 01	DT7395CA	Preliminary Manual
Rev 02	DT7395CA	Miscellaneous Editing Updates
Rev 03	DT7395CA	Pictures Updated
Rev 04	DT7395CD	Accessories Added
Rev 05	DT7395CF	Added Pacer Graphing, Auto Sequences
Rev 06	DT7395CF	Miscellaneous Editing Updates

LIMITED WARRANTY

WARRANTY: BC GROUP INTERNATIONAL, INC. WARRANTS ITS NEW PRODUCTS TO BE FREE FROM DEFECTS IN MATERIALS AND WORKMANSHIP UNDER THE SERVICE FOR WHICH THEY ARE INTENDED. THIS WARRANTY IS EFFECTIVE FOR TWELVE MONTHS FROM THE DATE OF SHIPMENT.

EXCLUSIONS: THIS WARRANTY IS **IN LIEU OF** ANY OTHER WARRANTY EXPRESSED OR IMPLIED, INCLUDING, BUT NOT LIMITED TO ANY IMPLIED WARRANTY OF **MERCHANTABILITY** OR FITNESS FOR A PARTICULAR PURPOSE.

BC GROUP INTERNATIONAL, INC. IS NOT LIABLE FOR ANY INCIDENTAL OR CONSEQUENTIAL DAMAGES.

NO PERSON OTHER THAN AN OFFICER IS AUTHORIZED TO GIVE ANY OTHER WARRANTY OR ASSUME ANY LIABILITY.

REMEDIES: THE PURCHASER'S SOLE AND EXCLUSIVE REMEDY SHALL BE: (1) THE REPAIR OR REPLACEMENT OF DEFECTIVE PARTS OR PRODUCTS, WITHOUT CHARGE. (2) AT THE OPTION OF **BC GROUP INTERNATIONAL, INC.**, THE REFUND OF THE PURCHASE PRICE.

This page intentionally left blank.

SPECIFICATIONS

ENERGY OUTPUT MEASUREMENT GENERAL	
METHOD	Monophasic or Biphasic
LOAD RESISTANCE	50 ohm +/- 1%, non-inductive (<1 μ H)
DISPLAY RESOLUTION	0.1 Joules
MEASUREMENT TIME WINDOW	100 ms
ABSOLUTE MAX PEAK VOLTAGE	6000 Volts
PULSE WIDTH	100 ms
CARDIOVERSION	
DELAY	0 to 6000 ms
RESOLUTION	0.1 ms
ACCURACY	+/-2 ms

ENERGY OUTPUT MEASUREMENT HIGH RANGE	
VOLTAGE	\leq 5000 Volts
MAX CURRENT	120 Amps
MAX ENERGY	1000 Joules
ACCURACY	+/-2% of reading for >100 Joules +/-2 Joules for <100 Joules
TRIGGER LEVEL	100 Volts
PLAYBACK AMPLITUDE	1 mv / 1000 V Lead 1
TEST PULSE	125 Joules +/- 20%

ENERGY OUTPUT MEASUREMENT LOW RANGE	
VOLTAGE	<1000 Volts
MAX CURRENT	24 Amps
MAX ENERGY	50 Joules
ACCURACY	+/-2% of reading for >20 Joules +/- 0.4 Joules for <20 Joules
TRIGGER LEVEL	20 Volts
PLAYBACK AMPLITUDE	1 mV / 1000 V Lead 1
TEST PULSE	5 Joules +/-20%

ENERGY OUTPUT MEASUREMENT OTHER	
OSCILLOSCOPE OUTPUT	
HIGH MEASURE RANGE	1000:1 amplitude-attenuated
LOW MEASURE RANGE	200:1 amplitude-attenuated
WAVEFORM PLAYBACK	
OUTPUT	LEAD I & PLATES
SCREEN	200:1 Time Base Expansion
SYNC TIME MEASUREMENTS	
TIMING WINDOW	Starts at peak of each R-wave
TEST WAVEFORMS	All waveform simulations available
DELAY TIME ACCURACY	+/- 1 ms
CHARGE TIME MEASUREMENT	
From 0.1 to 99.9 sec	

ECG NSR	
RATE	30,40,45,60,80,90,100,120,140,160,180,200,220,240,260,280,300 BPM
ACCURACY	+/- 1%
AMPLITUDE	0.5,1.0,1.5,2.0 mV (Lead II)
ACCURACY	+/- 2% @ Lead II
HIGH LEVEL	200 times Amplitude
ACCURACY	+/- 5%
QRS DURATION	80ms

ECG PERFORMANCE	
SINE WAVE	0.1,0.2,0.5,5,10,40,50,60,100 Hz
SQUARE WAVE	0.125, 2.000 Hz
TRIANGLE WAVE	2.000, 2.500 Hz
PULSE WAVE	30,60,120 BPM; 60 ms width
AMPLITUDE	0.5,1.0,1.5,2.0 mV (Lead II)
RATE ACCURACY	+/- 1%
AMPLITUDE ACCURACY	+/- 2% @ Lead II

ECG GENERAL	
LEAD TO LEAD IMPEDANCE (RL, LL, RA, LA)	1000 ohm
LEAD TO LEAD IMPEDANCE (V1-V6)	1000 ohm

ECG ARRHYTHMIA SELECTIONS
Ventricular Fibrillation
Atrial Fibrillation
Second Degree A-V Block
Right Bundle Branch Block
Premature Atrial Contraction
PVC Early
PVC Standard
PVC R on T
Multifocal PVC
Bigeminy
Run of 5 PVCs
Ventricular Tachycardia

SHOCK ADVISORY ALGORITHM TEST ECG SIGNALS
Asystole
Coarse Ventricular Fibrillation
Fine Ventricular Fibrillation
Multifocal Ventricular Tachycardia @ 140 BPM
Multifocal Ventricular Tachycardia @ 160 BPM
Polyfocal Ventricular Tachycardia @ 140 BPM
Polyfocal Ventricular Tachycardia @ 160 BPM
SupraVentricular Tachycardia @ 90 BPM

TRANSCUTANEOUS PACEMAKER ANALYZER TEST LOAD	
RANGE	50,100,150,200,300,400,500,600,700, 800,900,1000,1100,1200,1300,1400, 1500,1600,1700,1800,1900,2000, 2100,2200,2300 ohms
ACCURACY	50 to 1300 ohm +/-1% 1400 to 2300 ohm +/-1.5%

TRANSCUTANEOUS PACEMAKER ANALYZER OSCILLOSCOPE OUTPUT	
0 – 150 V	10.24:1 amplitude attenuation
15 – 60 V	41:1 amplitude attenuation
> 60 V	164:1 amplitude attenuation
MAX OUTPUT	200 V

TRANSCUTANEOUS PACEMAKER ANALYZER PULSE MEASUREMENTS	
CURRENT	4 to 300 mA (100 ohm load)
ACCURACY	+/-5% or +/-0.5 mA (whichever is greater)
RATE	30 to 800 ppm
ACCURACY	+/-1% or 2 ppm (whichever is greater)
PULSE WIDTH	0.6 to 80 ms
ACCURACY	+/-1% or +/-0.3 ms (whichever is greater)
MAX VOLTAGE	200 V (Variable Load Input Jacks) 15 V (Fixed Load Input Jacks)
PACE LIMIT	
PACE LOAD (Ohms)	CURRENT (mA)
50	300
100	300
150	300
200	300
300	300
400	300
500	300
600	300
700	286
800	250
900	222
1000	200
1100	182
1200	167
1300	154
1400	143
1500	133
1600	125
1700	118
1800	111
1900	105
2000	100
2100	95
2200	91
2300	87

TRANSCUTANEOUS PACEMAKER ANALYZER DEMAND SENSITIVITY	
WAVEFORMS	
SELECTIONS	Square Triangle Haversine
WIDTH	10,25,40,100,200 ms
ECG OUTPUT	
AMPLITUDE – OUT	0 to 4 mV
RESOLUTION – OUT	40 μ V
ACCURACY – OUT	+/-2%
PACER INPUT (50 TO 400 OHMS)	
AMPLITUDE – OUT	0 to 10 mV / 50 Ohms
RESOLUTION – OUT	40 μ V
ACCURACY – OUT	+/-2%
RATE – IN	30 to 120 ppm
PACER INPUT (500 TO 2300 OHMS & OPEN)	
AMPLITUDE – OUT	0 to 100 mV
RESOLUTION – OUT	1mV
ACCURACY – OUT	+/-2%
RATE – IN	30 to 120 ppm
DEFIBRILLATOR PLATES	
AMPLITUDE – OUT	0 to 10 mV
RESOLUTION – OUT	0.1 mV
ACCURACY – OUT	+/-2%
RATE – IN	30 to 120 ppm

TRANSCUTANEOUS PACEMAKER ANALYZER 50/60 HZ INTERFERENCE TEST SIGNAL	
ECG OUTPUT	0,0.4,0.8,1.2,1.6,2.0,2.4,2.8, 3.2,3.6,4.0 mV
PACER INPUT 50 OHMS	0,1,2,3,4,5,6,7,8,9,10 mV
PACER INPUT 100 OHMS	0,2,4,6,8,10,12,14,16,18,20 mV
PACER INPUT 150 OHMS	0,3,6,9,12,15,18,21,24,27,30 mV
PACER INPUT 200 OHMS	0,4,8,12,16,20,24,28,32,26,40 mV
PACER INPUT 300 OHMS	0,6,12,18,24,30,36,42,48,54,60 mV
PACER INPUT 400 OHMS	0,8,16,24,32,40,48,56,64,72,80 mV
PACER INPUT \geq 500 OHMS	0,10,20,30,40,50,60,70,80,90,100 mV
DEFIBRILLATOR PLATES	0,1,2,3,4,5,6,7,8,9,10 mV

TRANSCUTANEOUS PACEMAKER ANALYZER REFRACTORY PERIOD	
PACING	20 to 500 ms
SENSING	20 to 500 ms
ACCURACY	+/-2 ms

DATA INPUT/OUTPUTS
Parallel Printer Port
RS-232C (for computer control)

PHYSICAL	
DISPLAY	LCD Graphical 240 X 64 Pixels, Backlit
ENCLOSURE	3.4 x 9.8 x 10.7 Inches (86.4 x 249 x 271.8 mm) Royalite R59 UL Flame Rating 94 V-0
WEIGHT	< 5 Lbs (< 2.3 Kg)
FACE PLATE	Lexan, Back printed
OPERATING RANGE	15 to 40 C
STORAGE RANGE	-20 to 65 C

ELECTRICAL	
POWER	Battery, 9 VDC (2 required) (NE 1604) Alkaline
BATTERY ELIMINATOR	BC20 - 21103 (120 VAC) (US Version) BC20 - 21101 (220 VAC) (Euro Version) 10V, 300 mA DC 

NOTES

**SECTION A
USER MANUAL
DA-CS-06
REV 02**



DEFIBRILLATOR ANALYZER CALIBRATION STANDARD

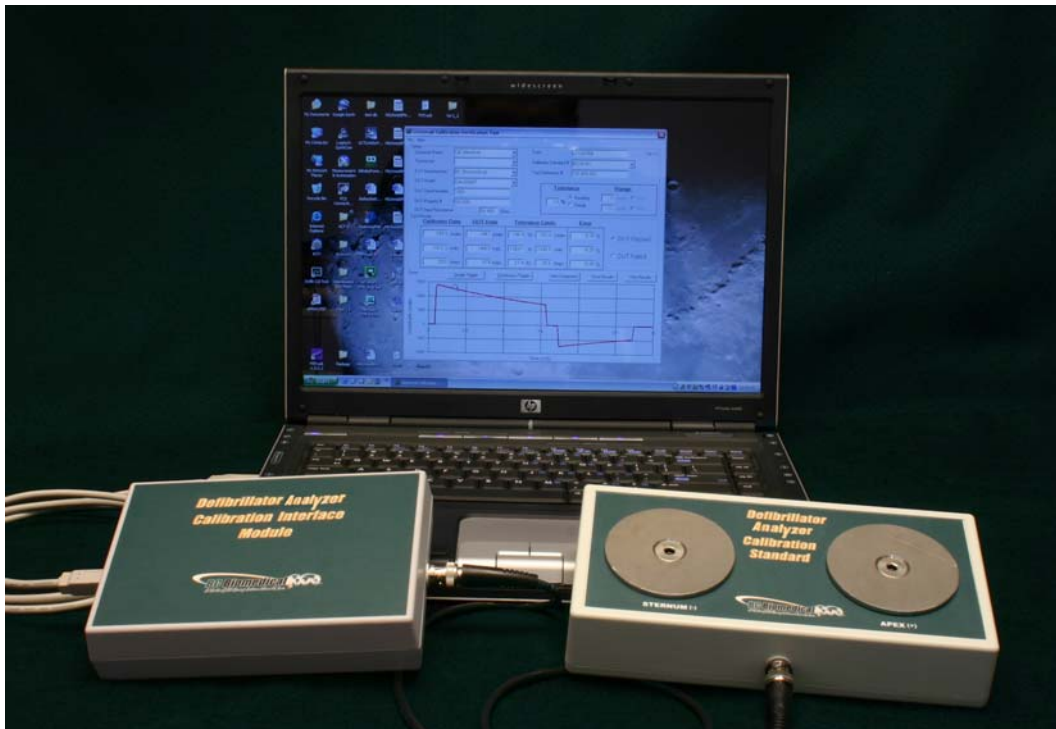

DA-CS-06

USER MANUAL

**BC BIOMEDICAL
DA-CS-06
TABLE OF CONTENTS**

WARNINGS	2
DESCRIPTION.....	4
OVERVIEW.....	5
CALIBRATION VERIFICATION SOFTWARE.....	6
MAIN SCREEN OVERVIEW	6
MENUS – FILE.....	7
MENUS – VIEW	8
TEST SETUP	9
TOLERANCE ADJUSTMENT.....	10
TEST RESULTS.....	10
CONTROL BUTTONS.....	11
AUTO-SCALING GRAPH.....	12
MANUAL REVISIONS.....	13
WARRANTY.....	13
SPECIFICATIONS	14
NOTES.....	15

WARNING

The DA-CS-06
is for use by
skilled technical personnel only.

WARNING

The DA-CS-06 is intended for calibration of
Defibrillator Analyzers only and should never be
used in diagnostics, treatment or any other
capacity where they would come in contact with
a patient.

WARNING

All connections to patients must be removed
before connecting the Device Under Test (DUT)
to the Analyzer. A serious hazard may occur if
the patient is connected when testing
with the Analyzer.
Do not connect any leads from the patient
directly to the Analyzer or DUT.

NOTICE

BC GROUP INTERNATIONAL, INC. RESERVES THE RIGHT TO MAKE CHANGES TO ITS PRODUCTS OR SPECIFICATIONS AT ANY TIME, WITHOUT NOTICE, IN ORDER TO IMPROVE THE DESIGN OR PERFORMANCE AND TO SUPPLY THE BEST POSSIBLE PRODUCT. THE INFORMATION IN THIS MANUAL HAS BEEN CAREFULLY CHECKED AND IS BELIEVED TO BE ACCURATE. HOWEVER, NO RESPONSIBILITY IS ASSUMED FOR INACCURACIES.

CONTACT INFORMATION

BC BIOMEDICAL
BC GROUP INTERNATIONAL, INC.
PO BOX 25125
9415 GENTRY AVE
ST. LOUIS, MO 63125
USA

1-800-242-8428
314-638-3800

www.bcgrouintl.com
sales@bcgrouintl.com

<p style="text-align: center;">BC GROUP DA-CS-06 DEFRILLATOR ANALYZER CALIBRATION STANDARD</p>

The Model DA-CS-06 is a sophisticated calibration standard system for Defibrillator Analyzers. It consists of a Standard, an Interface Module and a PC-based Software Interface.

The following are highlights of some of the main features:

- WORKS WITH DEFIBRILLATOR ANALYZERS FROM ALL MANUFACTURERS
- USES THE LOAD IN THE ANALYZER FOR MAXIMUM ACCURACY
- 16 BIT A/D RESOLUTION
- 10,000 SAMPLES
- PC-BASED DIGITAL INTEGRATOR
- FULL WINDOWS SOFTWARE FEATURES
- FULL NIST TRACEABILITY
- CALIBRATION IS MAINTAINED IN THE HARDWARE, NOT THE SOFTWARE, FOR EASE OF RECALIBRATION
- SINCE VERIFICATION IS DONE BY COMPARISON, ANY DEFIB SOURCE MAY BE USED TO GENERATE INPUT

OVERVIEW

This section looks at the layout of the DA-CS-06 and gives descriptions of the elements that are present and shows how they should be connected.

Sample Defibrillator
NOTE: A specific Defibrillator is not necessary to verify the calibration of a Defibrillator Analyzer to the presented Standard. This is a sample of a typical source.

Sample Defibrillator Analyzer
NOTE: The Device Under Test (DUT) must be Earth Grounded. This is typically done through the Serial Port.

Calibration Verification Software
PC-based program for control and display of results to verify a Defibrillator Analyzer falls within the presented Standard.



Calibration Standard
Plugs into the Input Jacks in the center of the Defib Plates on the Defibrillator Analyzer and has a BNC cable that is connected to the Interface Module

Interface Module
Connects via a BNC cable to the Calibration Standard and via a USB cable to the PC running the Calibration Verification Software

CALIBRATION VERIFICATION SOFTWARE

MAIN SCREEN OVERVIEW

The following is a general overview of the main operating screen. Each part of this Main Screen is described in full detail later in this section.

Menus—File and View
Used to configure the program and for data loading/storing.

Test Setup
Used to identify the Device Under Test (DUT) for reference purposes. This data is included on printouts and in the saved data files.

Tolerance Adjustment
Used to modify the tolerance for DUT Pass/Fail determination

Test Results
Used to display the results of the test.

NOTE: The DUT data must be manually entered.

Control Buttons
Used for quick access to common operations.

Auto Scaling Graph
Used to show the energy delivered to the DUT.

MENUS – FILE

File Menu:

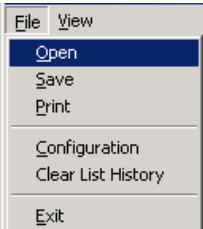

Open – This option allows you to view a previously stored test.

Save – This option allows you to save the latest test data in a Microsoft Excel file for future reference.

Print – This option prints the latest test data.

Configuration – This option opens the test configuration window.

Clear List History – This option opens the clear list history window.

Exit – This option exits the program.

Configuration Window: This window is used to configure the Channel and Timing Parameters.

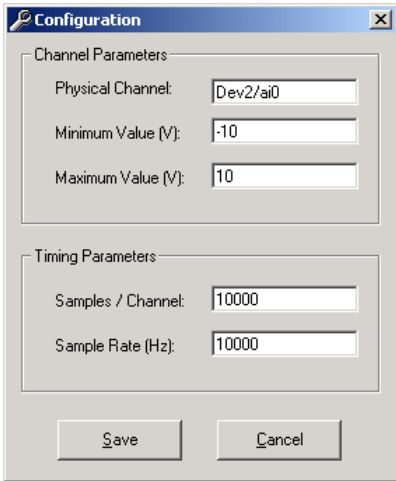

Physical Channel – This field identifies the calibrator being used and must match the Device ID.

Minimum Value – This is the minimum scaled voltage that the A/D converter can read.

Maximum Value – This is the maximum scaled voltage that the A/D converter can read.

Samples / Channel – This is the number of datapoints collected from each read of the A/D converter.

Sample Rate – This is the number of samples taken per second.

Clear List History Window: This box is used to erase the history of any drop down data entry boxes.

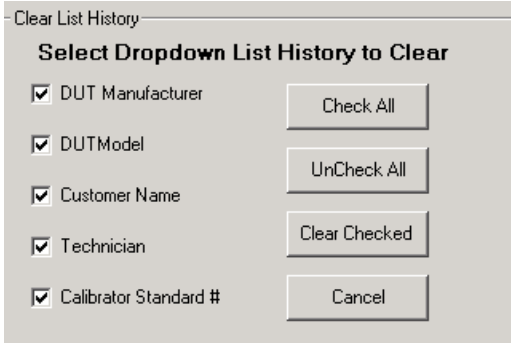

MENUS – VIEW

View Menu: This menu allows the user to select which program sections are visible to the user and which data is included in the report print-outs.



Display Option – This option drops down the Display Option List.

Print Option – This option drops down the Print Option List.

Display Options List:

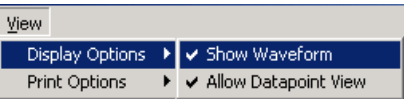

Show Waveform – This option determines whether the waveform graph is shown on the screen.

Allow Datapoint View – This option determines whether the user can view the individual voltage readings measured by the A/D converter.

Print Options List:

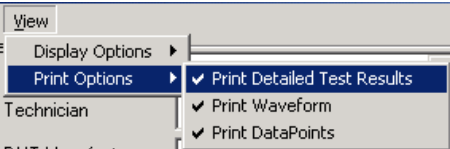

Print Detailed Test Results – This option determines if the report printout contains just a Pass/Fail, or if it also includes the Calibrator Data, DUT Data, Tolerance Limits and % Error.

Print Waveform – This option determines if the waveform plot is included in the report printout.

Print Datapoints – This option determines if the individual A/D datapoints are included in the report printout.

TEST SETUP

The Test Setup part of the Main Screen is used to enter all of the information about the DUT, as well as, the user and calibrator being used. All of the fields that have a drop down arrow maintain a history of entries. As data is entered, it is compared to any entry previously used. If a new entry is made, it is added to the history list for quick future reference. (See the Menu – File section for clearing the list histories.)

The screenshot shows a software interface titled "Setup" with a version number "Ver 1.3a" in the top right corner. The interface is divided into two main columns. The left column contains several fields: "Customer Name" (a dropdown menu), "Technician" (a dropdown menu), "DUT Manufacturer" (a dropdown menu), "DUT Model" (a dropdown menu), "DUT Serial Number" (a text input field), "DUT Property #" (a text input field), and "DUT Input Resistance" (a text input field followed by "Ohms"). The right column contains: "Date" (a text input field), "Calibrator Standard #" (a dropdown menu), and "Test Reference #" (a text input field). Below these fields is a section titled "Tolerance" and "Range". Under "Tolerance", there is a text input field containing "2" followed by a percentage sign "%". There are two radio buttons: "Reading" (which is selected) and "Range". Under "Range", there are two text input fields: one containing "50" followed by "Joules" and a radio button labeled "Low", and another containing "1000" followed by "Joules" and a radio button labeled "High" (which is selected).

Customer Name – This field is used to enter the owner of the Device Under Test (DUT).

Technician – This field is used to enter the name of the person performing the test.

DUT Manufacturer – This field is used identify the manufacturer of the DUT.

DUT Model – This field is used to identify the model number of the DUT.

DUT Serial Number – This field is used to identify the serial number of the DUT

DUT Property Number – This field is used for additional tracking numbers associated with the DUT.

DUT Input Resistance – This field is used to enter the Input Resistance of the DUT.

NOTE: This field must be updated with each DUT. This is used for the power computation and will cause reading errors if it does not match the DUT input impedance.

Date – This field is automatically updated when the program is opened.

Calibrator Standard Number – This field is used to identify the calibrator that is being used for the test.

Test Reference Number – This field is used for tracking the test data.

TOLERANCE ADJUSTMENT

Tolerance	Range
<input type="text" value="2"/> % <input checked="" type="radio"/> Reading <input type="radio"/> Range	<input type="text" value="50"/> Joules <input type="radio"/> Low <input type="text" value="1000"/> Joules <input checked="" type="radio"/> High

Tolerance – The test limits can be calculated as either % of Range or % of Reading.

Range – If % of Range is used, the Range needs to be properly selected.

TEST RESULTS

The Test Results part of the Main Screen contains the results of the latest pulse delivered to the defibrillator.

Test Results			
Calibrator Data	DUT Data	Tolerance Limits	Error
<input type="text" value="199.8"/> Joules	<input type="text" value="197.6"/> Joules	<input type="text" value="203.8"/> to <input type="text" value="195.8"/> Joules	<input type="text" value="-1.10"/> %
<input type="text" value="1396.3"/> Volts	<input type="text" value="1390.1"/> Volts	<input type="text" value="1424.2"/> to <input type="text" value="1368.4"/> Volts	<input type="text" value="-0.44"/> %
<input type="text" value="27.8"/> Amps	<input type="text" value="27.7"/> Amps	<input type="text" value="28.4"/> to <input type="text" value="27.2"/> Amps	<input type="text" value="-0.36"/> %

DUT Passed
 DUT Failed

Calibrator Data – This data is automatically entered as the defibrillator pulse is analyzed by the calibrator.

NOTE: In order for this data to be correct, the DUT input impedance must be correct.

DUT Data – This data is the readings taken by the DUT.

NOTE: This information must be entered manually by the user.

Tolerance Limits – This section shows the valid range of DUT Data based on the tolerances selected in the Test Setup section.

Error – This section shows the % error between the Calibrator Data and DUT Data based on the % of Range or % of Reading selection in the tolerance configuration.

DUT Passed/Failed – This section indicates whether the test Passed or Failed based on the tolerances selected in the Test Setup section.

CONTROL BUTTONS

These buttons are used to control the operation of the program.



Single Trigger – This button will initiate the sampling of the A/D converter inputs. 10,000 samples are buffered by the A/D converter and scanned for a valid defibrillator pulse. The A/D converter will continuously scan the input until a pulse is detected. When a valid pulse is detected, it is analyzed and the A/D converter stops reading the calibrator input.

NOTE: It is possible for the Calibrator to “miss” a pulse if it occurs during the time that the samples are transferred from the calibrator to the PC.

NOTE: If the pulse occurs too late in the sample buffer, there will not be enough samples to properly analyze the pulse and the test will need to be repeated, in which case, an error message will be displayed.

Continuous Trigger – This button configures the A/D converter to not stop after detecting the defibrillator pulse. It will continuously scan the A/D input for further defibrillator pulses. This can be useful when doing quick visual comparisons on the DUT.

The data can be entered, printed and saved as normal; however, the PC will operate slowly due to the traffic on the USB.

View Datapoints – This button will show all of the voltage readings taken by calibrator that were used in the pulse analysis.

NOTE: This button may not always be available
(See the Menu – View section for display options).

Save Results – This button allows the user to save the data to an Excel spreadsheet.

NOTE: All data will be saved, even if it is not shown on the screen
(See the Menu – View section for display options).

Print Results – This button allows the user to print the collected data.

AUTO-SCALING GRAPH

The Waveform part of the Main Screen shows the pulse that was detected by the calibrator.

NOTE: Only 15mS of data is used in the pulse analysis.

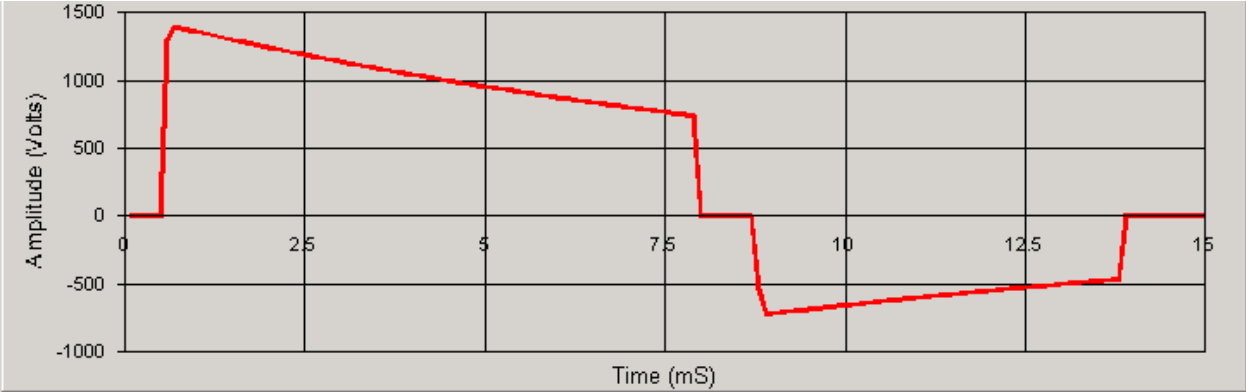

MANUAL REVISIONS

<u>Revision #</u>	<u>Engineering #</u>	<u>Revisions Made</u>
Rev 01	DT7375	Preliminary Manual
Rev 02	DT7375	Specification Method Updated

LIMITED WARRANTY

WARRANTY: BC GROUP INTERNATIONAL, INC. WARRANTS ITS NEW PRODUCTS TO BE FREE FROM DEFECTS IN MATERIALS AND WORKMANSHIP UNDER THE SERVICE FOR WHICH THEY ARE INTENDED. THIS WARRANTY IS EFFECTIVE FOR TWELVE MONTHS FROM THE DATE OF SHIPMENT.

EXCLUSIONS: THIS WARRANTY IS **IN LIEU OF** ANY OTHER WARRANTY EXPRESSED OR IMPLIED, INCLUDING, BUT NOT LIMITED TO ANY IMPLIED WARRANTY OF **MERCHANTABILITY** OR FITNESS FOR A PARTICULAR PURPOSE.

BC GROUP INTERNATIONAL, INC. IS NOT LIABLE FOR ANY INCIDENTAL OR CONSEQUENTIAL DAMAGES.

NO PERSON OTHER THAN AN OFFICER IS AUTHORIZED TO GIVE ANY OTHER WARRANTY OR ASSUME ANY LIABILITY.

REMEDIES: THE PURCHASER'S SOLE AND EXCLUSIVE REMEDY SHALL BE: (1) THE REPAIR OR REPLACEMENT OF DEFECTIVE PARTS OR PRODUCTS, WITHOUT CHARGE. (2) AT THE OPTION OF **BC GROUP INTERNATIONAL, INC.**, THE REFUND OF THE PURCHASE PRICE.

SPECIFICATIONS

GENERAL SPECIFICATIONS	
METHOD	Monophasic or Biphasic Waveforms (Including: Edmark, Lown, trapezoidal, biphasic rectilinear, biphasic truncated exponential, etc.)
DISPLAY RESOLUTION	0.1 Joules
MEASUREMENT TIME WINDOW	1000 ms
ABSOLUTE MAX PEAK VOLTAGE	6000 Volts
PULSE WIDTH	15 ms
ACCURACY	+/- 0.2% Reading
RESOLUTION	16 Bit
CALIBRATION INTERVAL	1 Year
TRIGGER LEVEL	250 Volts
OPERATING RANGE	15 to 40 C
STORAGE RANGE	-20 to 65 C

PHYSICAL – INTERFACE MODULE	
CONNECTION: CALIBRATION STANDARD	BNC
CONNECTION: PC	USB 2.0 High Speed
POWER CONSUMPTION	500mA Max, From USB
OS COMPATIBILITY	Windows 2000, XP
FACE PLATE	Lexan, Back printed
ENCLOSURE	6.8 x 4.8 x 1.5 Inches (172.7 x 121.9 x 38.1 mm)
WEIGHT	< 1Lbs (< 0.45 Kg)

PHYSICAL – CALIBRATION STANDARD	
CONNECTION: DUT	Banana Plug, 4.6" Spacing (Custom Interface available upon request)
CONNECTION: DEFIBRILLATOR	Defib Plates, Banana Jack, 4.6" Spacing
CONNECTION: INTERFACE MODULE	BNC
FACE PLATE	Lexan, Back printed
ENCLOSURE	8.7 x 4.3 x 1.7 Inches (221.0 x 109.2 x 43.2 mm)
WEIGHT	< 1Lbs (< 0.45 Kg)

NOTES

SECTION B

OPERATIONAL THEORY

The DA2006P Defibrillator Analyzer with Pace is a microcontroller based high precision energy analyzer for measuring the energy of a defibrillator pulse. It also measures Transcutaneous Pace Pulses and performs Refractory Period, Sensitivity and Immunity testing.

The DA2006P can measure both monophasic and biphasic pulses. Absolute maximum voltage is ± 6000 Volts and the measurement window is 100 milliseconds. There are two ranges, 50 and 1000 Joules.

The DA2006P can measure pace pulses with an amplitude of 4 to 300 mA, with widths from 0.6 to 80 milliseconds. Rate limits are from 30 to 800 ppm.

The DA2006P also generates ECG, NSR, Arrhythmia and performance waveforms.

The analyzer consists of a user interface, analog to digital converter, digital to analog converters, pacer load selection, communications interface and a centronics printer port.

OVERVIEW

The DA2006P energy pulse function is based on converting the output from a defibrillator to a digital value. The defibrillator is discharged into a fixed 50 ohms non-inductive load. The resulting voltage drop across this resistor is divided by a series of resistors and converted from an analog voltage to a digital count by the analog-to-digital (A/D) converter. This value is then processed by the microprocessor and displayed on the LCD. To properly evaluate the defibrillator pulse, the A/D converter samples 10,000 times per second.

The pace pulse is also analyzed by an A/D converter. The load resistance for the pace function can be the same load resistance for the defib pulse or a separate set of internal load resistors can be used. This allows the user to be able to analyze the pace pulse at many different loads.

ECG waveforms, along with performance waveforms are generated by an internal digital to analog converter and are available on the ten patient lead connectors.

USER INTERFACE

The user interfaces with the analyzer via the 240x64 pixel Backlit LCD display and the keys. The LCD display is a full graphical display and is continually updated to inform the user of the current operating conditions. The seven keys allows the user the ability to setup and operate the analyzer with a minimal number of keystrokes. The keys labeled F1 through F5 change function based on the current operating mode of the DA2006P. The lower section of the display is used to identify the function of these keys at any given time.

POWER SUPPLIES

The DA2006P analyzer can be powered from an AC line transformer or from the built in 9 volt batteries. The AC line power adapter jack is located at the back of the instrument. The power is connected to the power supply board via connector J4 for the AC adapter input and via J5 and J6 for the batteries. All power sources are protected from reverse connection through blocking diodes CR2, CR3, and CR4. Both options are connected through switch, SW1, to U1 which regulates the incoming power to 5 VDC. This 5 VDC is used to power the digital circuits.

U3 is used to generate the -9 supply for the backlight and analog circuitry. U2:A is used to generate the adjustable negative supply for the LCD contrast. All of the supplies are passed to the analog and micro boards through the ribbon cable on P1.

On the Analog board, U15 and U16 are used to generate the power supplies for the analog circuitry.

On the Microprocessor board, U11 is used to generate a local 5volt supply for the microprocessor and logic circuitry.

MICROCONTROLLER

The microcontroller, U3, is a 16 bit central processing unit with built in peripherals. The microcontroller utilizes a 16 bit data path. The microcontroller contains flash programmable EEPROM, RAM asynchronous serial communications interfaces, serial peripheral interfaces, etc. An external crystal is used to set the operational frequency at 24MHz. Watchdog functions are built into the chip.

PRINTER PORT

The printer port consists of an 8 bit data bus driven from the microprocessor as well as 8 I/O control signals. U4, U5, U7 and U9 are used to decode the Address/Data bus and provide the chip select signals for the printer port data latch. The control signals are used to read the status of the printer as well as control the data flow to the printer. The filters L2 through L23 on the power supply board are used to provide electrostatic discharge protection and noise filtering to the printer I/O signals.

SERIAL PORT

The serial port is used to communicate with a host PC. The port is fixed at 115,200 Baud, 8 Data Bits, 1 Stop bit, No parity. U1 on the microprocessor board is used to generate the RS-232 voltage levels. L6, L8 and L11 on the power supply board are used to provide electrostatic discharge protection and noise filtering to the serial port signals. R4, R6, and R8 on the power supply board are used to provide short circuit protection to the serial port signals. The port is configured for a direct to PC connection, a null modem is not needed.

DEFIBRILLATOR CIRCUITRY

The defibrillator circuitry consists of a voltage input measurement section as well as an analog output section. The input circuitry is used to measure the defibrillator discharge pulse or the pacemaker pulse. The analog output is used to generate ECG or pacemaker test waveforms.

The input circuit begins with the power resistors R22 and R25. These are 25 Ω , 100 W, Non-Inductive power resistors. These resistors absorb the power from the defibrillator discharge pulse. Connected to these power resistors is a series of 16 low power resistors R12 through R19 and R26 through R33. The purpose of these resistors is to divide the voltage of the defibrillator discharge pulse. U1A is the differential amplifier that is used to measure the divided voltage. The relays RL1 and RL2 are used along with R1, R2, R3, R6, R7, and R8 to select the gain for either Low Range Defibrillator input, High Range Defibrillator Input, or Pacemaker input measurements.

The amplifier U1:C is used to generate the zero offset voltage for the Defibrillator input circuitry. U1:D is used to generate the self test waveform pulse. R4, R35, and RA1 are used to properly attenuate the self-test and input signals and provide gain adjustment. The output of U1:B is then connected to the A/D converter. The signal is offset by $\frac{1}{2}$ of the A/D reference voltage. This gives an analog range of 0 V = -2048 counts, 1.25V = 0 counts, and 2.5 V = 2047 counts. The output of U1:A is also connected to the multiplexer U8 to drive the scope output circuitry.

The defibrillator output circuitry consists of a series of 16 resistors R50 through R57 and R61 through R68. These resistors are connected to the defibrillator plates and are driven by the op amp U4. These resistors are used to provide protection to the output drive circuitry from the defibrillator discharge pulse. The op amp receives the same voltage signal as the ECG output. Resistors R47, R48, and R49 are used to scale the output signal to match the voltage of Lead I. For more information on how the ECG output is generated, see that section below.

PACEMAKER CIRCUITRY

The pacemaker circuitry consists of a variable load input as well as an analog output. The variable load consists of a series of power resistors R86, R89, R93, R98, R103, R116, R126, and R114. Relays RL4 through RL9 are used in combination to short out individual load resistors. U11 is used to drive the relays from the Micro controller SPI bus. The resistors that are not shorted determine the pacemaker input impedance. The differential amplifier U17 is used to condition the pacemaker input voltage. Amplifiers U5:B through U5:D provide multiple gain settings that allow for a measurement of a wide range of input voltages. These signals are then passed to the A/D converter, which selects the appropriate channel based on signal level.

The output circuitry consists of a differential output from amplifiers U10:C and U10:D. The D/A converter U9 along with amplifiers U10:B and U10:A scale the output signal based on the selected load. The output signal source is the same as the ECG Output.

OSCILLOSCOPE OUTPUT

The oscilloscope output is driven from multiplexer U8. The signals routed to the multiplexer are the same signals that are routed to the A/D converter. U7 provides buffering and filtering for the oscilloscope output. The microprocessor selects either the Defibrillator or Pacemaker signals based on the operating mode of the DA-2006P.

ECG OUTPUT

The ECG output consists of a D/A converter with a variable reference voltage. The reference voltage is generated by the microprocessor and buffered by U2:A. The reference voltage is used to select the ECG Output amplitude. The ECG output waveform is generated by the D/A converter U3. The output of the D/A converter is buffered and scaled by U2:B and U2C for the ECG output and U2:D for the High Level output. It is also routed to the Defibrillator Output amplifier U4:A and the Pacemaker output attenuator U9. The ECG signal is routed to the ECG distribution board via J1. The distribution board contains all of the resistive dividers used to generate the individual output voltages.

SECTION C VALIDATION / CALIBRATION

GENERAL CALIBRATION / VERIFICATION INFORMATION

Calibration is the procedure by which an instrument is adjusted to make its indicated values correspond as closely as possible with the actual values being measured. Verification is the process of determining if the instrument is operating within its specified tolerances. If the instrument fails the validation testing, Calibration must be performed to adjust the instrument into tolerance.

REQUIRED EQUIPMENT

The following equipment is needed for Validation / Calibration:

- ❑ DMM, Fluke 45 or Equivalent
- ❑ Battery Eliminator, 10VDC, 300mA, Regulated
- ❑ Adjustable Power Supply, 0-12VDC, 500mA
- ❑ Defibrillator (With pacemaker function for DA-2006P)
- ❑ BC Biomedical Defibrillator Analyzer Calibration Interface Module (DA-CS-06)
- ❑ PC Running the Calibration Interface Module software (DA-CS-06)
- ❑ Oscilloscope, Lecroy 9304AM or equivalent
- ❑ Centronics printer (DeskJet or Dot-Matrix)

VERIFICATION TESTS

Use the following procedure to verify the Unit Under Test (UUT) operation:

DEFIBRILLATOR INPUT TEST

1. Set DMM to measure resistance
2. Measure the resistance between the UUT defibrillator input plates. Resistance should be 49.5 to 50.5 Ω .
3. Connect the Calibration Interface Module to the UUT. (See the DA-CS-06 User Manual for more information.)
4. Set the UUT for High Range input mode.
5. Use Defibrillator to discharge at energy levels of 100, 200 and 360 Joules. Verify that UUT measurements are within tolerance (2% of the calibrator measurement) as shown on the PC display.
6. Run the UUT self-test waveform.
7. Measured power should be 100 to 150 Joules.
8. Set the UUT for Low Range Mode.
9. Use Defibrillator to discharge at energy levels of 5, 20, and 50 Joules. Verify that UUT measurements are within tolerance (2% of the calibrator measurement) as shown on the PC display.

NOTE: If Input Overload Warning, use next lower setting on source defibrillator.

10. Run the UUT self test waveform.
11. Measured Power should be 4 to 6 Joules

ECG OUTPUT TEST

1. Set the ECG Output to 0.125 Hz Performance Waveform, 2.0 mV Lead II.
2. Connect the DMM (+) terminal to LL, (-) terminal to RA
3. The measurement will alternate from positive to negative. On the negative reading, press the Zero button on the meter. When the Output goes positive, the meter will then display the output Span. For this test the span should be from 1.960 to 2.040 mVDC.
4. Connect the DMM (-) terminal to RL. Connect the (+) terminal to the following positions. Measure the span as shown in step 3.

(+) Terminal	Valid DMM Measurement of Span (mV)
RA	1.313 to 1.367
LA	2.705 to 2.815
LL	3.273 to 3.407
V1	2.822 to 2.938
V2	3.038 to 3.162
V3	4.057 to 4.223
V4	4.900 to 5.100
V5	4.057 to 4.223
V6	3.773 to 3.927

NOTE: The limits shown in the table above are for reference only based on ideal output voltage. Only Lead II amplitude accuracy is specified.

5. Connect the DMM (+) terminal to the Apex plate, (-) terminal to the Sternum plate.
6. The output span should be from 1.372 to 1.428 mV.
7. Connect the DMM to the Pacemaker Terminals (DA-2006P only).
8. The output span should be from 102.9 to 107.1 mV.
9. Connect the DMM to the High Level Output.
10. The output span should be from 392 to 408 mV.
11. Set the ECG Output to 100Hz Performance Sine wave
12. The output Frequency should be from 99 to 101 Hz.
13. Remove connections from UUT.

PRINTER PORT TEST (REFERENCE ONLY)

1. Connect a compatible printer to the UUT.
2. Press the Print Header button and validate the printer output.

SERIAL PORT TEST (REFERENCE ONLY)

1. Connect UUT to serial PC Serial port.
2. Using a terminal program such as Hyperterminal or Teraterm set to 115200 Baud, send a “V” and CR (carriage-return) to the UUT.
3. The UUT should respond with the current firmware revision “DT7349xxx”.

VARIABLE RESISTANCE LOAD (DA-2006P ONLY)

1. Connect DMM to Variable Load Pacer inputs.
2. Set UUT Mode to Pace mode. Verify resistance of each Load selection according to table below

Load Selection (ohms)	Valid DMM Measurement of Resistance (ohms)
50	49.5 to 50.5
100	99 to 101
150	148.5 to 151.5
200	198 to 202
300	297 to 303
400	396 to 404
500	495 to 505
600	594 to 606
700	693 to 707
800	792 to 808
900	891 to 909
1000	990 to 1010
1100	1089 to 1111
1200	1188 to 1212
1300	1287 to 1313
1400	1379 to 1421
1500	1477.5 to 1522.5
1600	1576 to 1624
1700	1674.5 to 1725.5
1800	1773 to 1827
1900	1871.5 to 1928.5
2000	1970 to 2030
2100	2068.5 to 2131.5
2200	2167 to 2233
2300	2265.5 to 2334.5

PACEMAKER INPUT TEST (DA-2006P ONLY)

1. Configure UUT Pacemaker load so that it is compatible with Defibrillator Pacemaker.
2. Using the Defibrillator Pacemaker output, apply a pacemaker signal to the UUT.
3. Verify pulse width and rate measurements with oscilloscope.
4. Verify current measurement by dividing measured pulse voltage by the measured UUT load resistance.

CALIBRATION

The Calibration procedure is used to adjust the UUT to comply with manufacturers specifications. This procedure should only be performed if the UUT failed the Defibrillator Input, Pacemaker Load Resistance or Pacemaker Input Verification tests. After calibration is performed, the Verification test should be run to validate the new calibration settings.

Part of the calibration can be performed Closed Box, other parts require Open Box. Closed Box refers to the digital calibration adjustments that do not require the technician to open the UUT.

NOTE: Opening the UUT will void the Manufacturer's Warranty. Not all calibration adjustments can be made Closed Box.

REQUIRED EQUIPMENT

The following equipment is needed for Validation / Calibration:

- ❑ DMM, Fluke 45 or Equivalent
- ❑ Battery Eliminator, 10VDC, 300mA, Regulated
- ❑ Adjustable Power Supply, 0-12VDC, 500mA
- ❑ Defibrillator (With pacemaker function for DA-2006P)
- ❑ BC Biomedical Defibrillator Analyzer Calibration Interface Module (DA-CS-06)
- ❑ PC Running the Calibration Interface Module software (DA-CS-06)
- ❑ Oscilloscope, Lecroy 9304AM or equivalent
- ❑ Centronics printer (DeskJet or Dot-Matrix)

CLOSED BOX CALIBRATION

1. Turn the UUT off.
2. Press and hold the Function Key to the right of the Backlight Key. Turn the UUT on. Hold this key until the Access code screen appears (after the startup screen).
3. Use the Up/Down arrows to select access code "1".
4. Press the Enter button to gain access to the Calibration menu.
5. Set the DMM to resistance mode.
6. Connect the DMM leads to each other, then press the Zero button on the DMM. This will offset any resistance due to the measurement leads.
7. Connect the DMM to the Defib Input plates.
8. On the UUT, use the UP and Down arrows to highlight the parameter labeled "Defib Load".
9. Press the Select button to modify the parameter.
10. On the UUT, use the UP and DOWN arrows to adjust the Defib Load parameter to match the measurement of the DMM.
11. Press ENTER when done.

CLOSED BOX CALIBRATION CONTINUED (DA-2006P ONLY)

1. Set the DMM to DCV mode.
2. Connect the DMM to the UUT Pacemaker inputs.
3. On the UUT, Press the DOWN arrow until the "50 ohms Offset" is selected.

NOTE: The display will indicate to connect the DMM to TP6 and TP7; this does not apply to this procedure and will only be applicable in the Open Box Calibration procedure.

4. Press Select to enable changes to the parameter.
5. Use the UP and DOWN arrows to adjust the offset parameter so that the DMM measures as close to 0VDC as possible
6. Repeats steps 3-5 for all pacemaker load selections.

OPEN BOX CALIBRATION

1. Perform the Closed Box Calibration procedure.
2. Remove the screws on the bottom of the UUT.
3. Open the UUT but leave the ribbon cable connected between the power supply board and the analog board. You will need access to the test points and potentiometers on the analog board while the UUT is powered.
4. Enter the Calibration menu as shown in steps 1-4 of the Closed Box calibration procedure.
5. On the UUT, Change the A/D Input Parameter to “Low Range”
6. Adjust Potentiometer RA2 so that the A/D Counts displays 0
7. Connect 4.00 VDC to TP3(+) and TP1(-) on the analog board.
8. Adjust Potentiometer RA1 on the analog board so that the A/D Counts display shows 2000.
9. Reverse the connections to the TP3 and TP1 terminals. A/D Counts display should show –1980 to –2020 counts.
10. Change the A/D Input parameter to “High Range”.
11. The A/D Counts should show –396 to –404 counts.
12. Reverse the connections to the TP3 and TP1 terminals.
13. The A/D Counts should show 396 to 404 counts.
14. Remove the 4.00 VDC from TP3 and TP1.
15. Set the A/D Input parameter to “Pace 0”.
16. Adjust Potentiometer RA3 so that the A/D Counts shows 0.
17. Connect 10.0 VDC to TP7(+) and TP6(-) on the analog board.
18. The A/D counts should show 98 to 102.
19. Set the A/D Input to “Pace 1”
20. The A/D counts should show 392 to 408 counts
21. Set the A/D Input to “Pace 2”
22. The A/D counts should show 1568 to 1632
23. Replace the screws on the bottom of the UUT.

SECTION D PARTS

TABLES		
Number	Title	Page
1	Top Level Assembly DA-2006P	D2
2	Wiring DA-2006P	D3
3	Circuit Board DA-2006 and DA-2006P – Patient Lead	D4
4	Circuit Board DA-2006 and DA-2006P – Input / Output	D7
5	Circuit Board DA-2006 and DA-2006P – Micro	D10-11
6	Circuit Board DA-2006 and DA-2006P – Analog	D14-16

DRAWINGS		
Number	Title	Page
21-739554-30-02	DA-2006 and DA-2006P Patient Lead Connector Board Parts Layout	D5
21-739549-30-03	DA-2006 and DA-2006P I/O Board Parts Layout	D8
21-739552-40-04	DA-2006 and DA-2006P Micro Board Parts Layout	D12
21-739556-40-04	DA-2006 Analog Board Parts Layout	D17
21-739601-40-04	DA-2006P Analog Board Parts Layout	D18

Table 1: TOP LEVEL ASSEMBLY DA-2006P

PART NUMBER	QUANTITY	DESCRIPTION	REFERENCE NUMBER
AM-0401	2	FITNG,PLUG,BANANA,6-32X3/8	-
AM-7395-02	10	CONNECTOR,SHORT,7395,DYTEC	-
AM-BH9V-04	2	BATTERY HLDR,9V,PLS	-
AM-J4MM-W	2	CONN,JACK,4MM,WHT,SAFETY	-
EA-7395	1	ENCLOSURE,DT7395,MOUNTING PLATE	-
EP-7395	1	ENCLOSURE, DT7395	-
HA-61/4-P	2	SCREW,6-32X1/4,NYLN,PAN	-
HA-63/4-F	8	SCREW,6-32X3/4,NYLON,FLAT	-
HC-41/4-P	10	SCREW,4-40X1/4,PH,PAN,SS	-
HC-43/8-P	3	SCREW,4-40X3/8,PH,PAN,SS	-
HC-61/4-P	15	SCREW,6-32X1/4,PH,PAN,SS	-
HC-63/8-P	8	SCREW,6-32X3/8,PH,PAN,SS	-
HG-0029	8	SPACER,PVC,SELF RETAIN	-
HM-0721	4	BUMPER,RECESSED,#4	-
HM-1181-1	0.8 ft	TAPE,COPPER FOIL,1"X18YRDS	-
HM-7395-01	2	DEFIB PLATE MTG SCREW,7395	-
HM-7395-02	2	DEFIB ANALYZER KNOB,7395	-
HM-7395-03	2	DEFIBRILLATOR PLATE,7395	-
HM-7395-04	1	INSULATOR,ENCLOSURE,7395	-
HM-7395-05	1	INSULATOR,ANALOG BOARD,7395	-
HN-L440	4	NUT,4-40,SS,W/NYLON INS LOCK	-
HN-S516-01	2	NUT,SS,5/16"	-
HP-7395-01	2	COVER PLATE,7395	-
HP-7395-03	2	SPACER,7395	-
HS-F609	8	STANDOFF,F/F,9/16,ABBATRON	-
HW-S004	10	WASHER,#4,INT TOOTH,SS	-
HW-S006	15	WASHER,#6,INT TOOTH,SS	-
HW-S516	4	WASHER,FLAT,5/16",SS	-
HW-S516-01	2	WASHER,SPLIT LCK,5/16",SS	-
HW-SF04-01	4	WASHER,FLAT,#4X1/4"OD,SS	-
TX-1003	1	TRNSFMR,10VDC,300MA	-

Table 2: WIRING DA-2006P

PART NUMBER	QUANTITY	DESCRIPTION	REFERENCE NUMBER
AI-T040-F	2	CONN,IDC,40 PIN,RIBBON	-
AJ-M002	1	HOUSING,2PIN,.156CC	-
AJ-M003	1	HOUSING,3PIN,.156CC	-
AJ-M005	1	HOUSING,5PIN,.156CC	-
AJ-M005	1	HOUSING,5PIN,.156CC	-
AM-A311	1	CNNCTR,BLKHEAD,RCPTCLE,AMPHENOL	-
AP-0114	4	PIN,.100CC,MOLEX	-
AP-0187	4	PIN,.156CC,MOLEX,7K REEL	-
HM-1181	0.1 ft	TAPE,FOIL,SHIELDING	-
JW-2715	1	WIRE,RUBR INSULATED,BLK	-
JW-9174	0.6 ft	CABLE,COAX,RG-174/U	-
WD-22BK	0.3 ft	WIRE,22AWG,BLACK	-
WD-22RD	.01 ft	WIRE,22AWG,RED	-
WR-40NN	1	CABLE,FLAT,40COND,28AWG	-
WH-0001	0.1 ft	HEAT SHRINK,1/8	-
WH-0002	0.15 ft	HEAT SHRINK,1/4	-

Table 3: CIRCUIT BOARD DA-2006 and DA-2006P – PATIENT LEAD

PART NUMBER	QUANTITY	DESCRIPTION	REFERENCE NUMBER
AH-M105	1	HEADER,5PIN	J1
AM-0836	1	CONNECTOR,1/4QC,TAB	QC1
BA-7395-P1	1	CKT BD,DT7395,REV2	-
DZ-68CA	1	DIODE, P6KE6.8CA	CR1
RB-0499	10	RESISTOR,499 OHMS	R2,R4,R6,R8,R10,R12,R14, R16,R18,R20
RB-K100	1	RESISTOR,100K OHMS	R15
RB-K121	2	RESISTOR,121K OHMS	R13,R17
RB-K130	1	RESISTOR,130K OHMS	R19
RB-K149	1	RESISTOR,149K OHMS	R7
RB-K162	1	RESISTOR,162K,1/4W,1%	R11
RB-K174	1	RESISTOR, 174K OHMS	R9
RB-K182	1	RESISTOR, 182K OHMS	R3
RB-K372	1	RESISTOR,372K OHMS	R1
UE-0310	10	SUPPRESSOR,TE FILTER	L1 thru L10

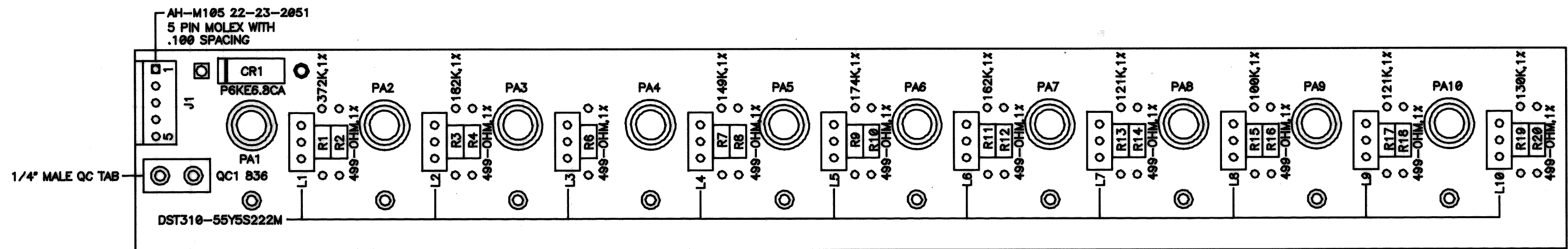

BC GROUP DA-2006 (DT7395) AND DA-2006P (DT7396) PATIENT LEAD CONNECTOR BOARD PARTS LAYOUT
 DATE: 01/03/06
 DRAWING NO. 21-739554-30-02
 PATH=E:\CC\DT7395\BC7395P2.PCB
 NOTE: USE DT7395 PATIENT LEAD CONNECTOR BOARD REV 2

Table 4: CIRCUIT BOARD DA-2006P – INPUT / OUTPUT

PART NUMBER	QUANTITY	DESCRIPTION	REFERENCE NUMBER
AD-0009-14	1	CONN,D-SUB,9PIN,F,R/A	J3
AD-0025-5	1	CONN,D-SUB,25P,F,R/A,PCB MNT	J2
AH-M103	2	HEADER,3PIN..100CC	J5,J6
AI-CB40-02	1	HEADER,IDC,40PIN	P1
AJ-C001	1	CONN,JACK,RCA,R/A,PCB,BLK	J1
AM-0006	4	LUG TEST POINT	TP1 thru TP5
AM-0007	1	CONN,JACK,POWER,RT ANGLE	J4
AM-0836	1	CONNECTOR,1/4QC,TAB	QC1
BA-7395-11	1	CKT BD,DT7395,I/O,REV3	-
CC-N010-20	1	CAP,.01uF,25V	C10
CC-N100-50	5	CAP,.1uF,50V	C3,C4,C7 thru C9
CR-M022-20	3	CAP,22uF,25V	C2,C5,C6
CR-M220-10	1	CAP,220uF,16V	C1
DA-4148	2	DIODE,1N4148,XXV,XA	CR1,CR5
DA-5817	4	DIODE,1N5817,20V1A	CR2,CR3,CR4,CR7
IC-0291-01	1	IC,DUAL OP AMP,OP291	U2
IC-7660	1	IC,ICL7660,DC-DC VLT	U3
IR-0385	1	VOLT REG,LM385Z-2.5	CR6
IR-2936-5	1	VOLT,5.0V,LOW PWR,LOW OUT	U1
RA-0010	5	RESISTOR,10 OHMS	R3,R8,R10,R12,R13
RA-0100	2	RESISTOR,100 OHMS	R4,R6
RA-3300	2	RESISTOR,3.3K OHMS	R7,R9
RB-0499	1	RESISTOR,499 OHMS	R1
RB-6810	1	RESISTOR,6.81K OHMS	R11
RB-K020	1	RESISTOR,20.0K OHMS	R14
RB-K100	1	RESISTOR,100K OHMS	R5
RB-K162	1	RESISTOR,162K,1/4W,1%	R2
RM-5000-02	1	POT,5K OHMS	RA1
RN-K120-9C	1	RES,NETWORK,120K OHMS	RP1
SR-0006	1	SWITCH,ROCKER,SPDT,PCB	SW1
UE-0310	25	SUPPRESSOR,TE FILTER	L1 thru L25
UI-M003	1	CHOKE,M9331,DIGIKE	L26

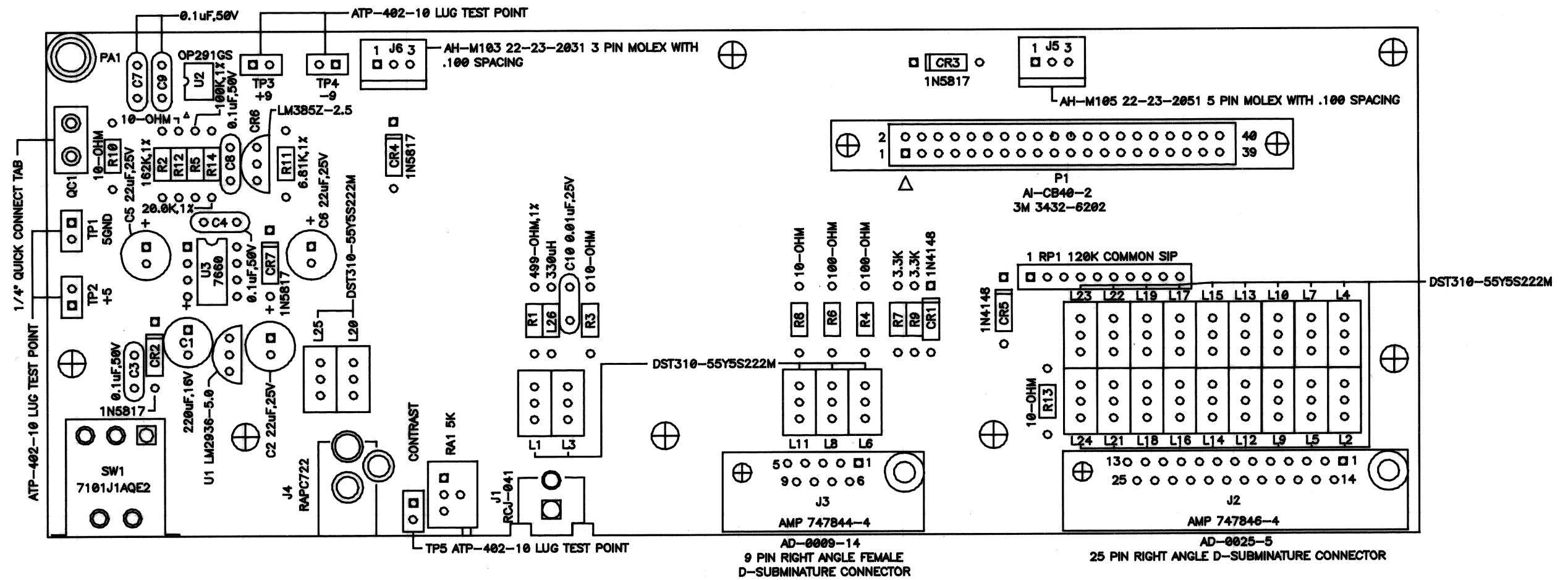

BC GROUP DA-2006 (DT7395) AND DA-2006P (DT7396)
 DEFIBRILLATOR ANALYZER I/O BOARD PARTS LAYOUT
 DATE: 12/27/05
 DWG NO. 21-739549-30-03
 PATH=E:\CC\DT7395\BC7395I3.PCB
 NOTE: USE DT7395 I/O BOARD REV 3 CIRCUIT BOARD

Table 5: CIRCUIT BOARD DA-2006P – MICRO

PART NUMBER	QUANTITY	DESCRIPTION	REFERENCE NUMBER
AH-AF36	1.4	HEADER,FEMALE,36/40	J1
AH-AM36-D	0.2	HEADER,MALE,36PIN,DBL	J2
AH-JB2B	1	CONN,HEADER,2POS,LATCH	J5
AH-H536	2	CONN,RECPT,36POS,.5MM	J3,J4
AH-M103	1	HEADER,3PIN..100CC	J6
AM-0006	2	LUG TEST POINT	TP1,TP2
BA-7395-M1	1	CKT BD,DT7395,MICRO,REV4	-
CC-N010-20	2	CAP,.01uF,25V	C5,C17
CC-N022-50	1	CAP,CER,.022UF,50VOLT	C12
CC-N100-50	20	CAP,.1uF,50V	C3,C7,C9,C11,C15,C16,C20 thru C29,C31,C36 thru C39
CC-N220-50	1	CAP,CER,.22UF,50VOLT	C13
CC-P022-50	2	CAP,22pF,50V	C18,C19
CR-M022-20	2	CAP,22uF,25V	C2,C4
CR-M220-10	1	CAP,220uF,16V	C33
CT-M001-20	1	CAP,1uF,25V DIPTAN	C41
CT-M001-30	1	CAP,1.0uF,35V,TAN	C1
CT-M010-25	10	CAP,10uF,25V,TAN	C6,C8,C10,C14,C25,C30,C3 2,C34,C35,C40
DA-5817	1	DIODE,1N5817,20V1A	CR1
GC-5185-2	1	DISPLAY,F-51851GNFJ-SLW-AEN	-
HB-3512-F	4	SCREW,M3X.5X12MM,PHL,FLAT,ZNC	-
HG-0015	4	SPACER,0.070",#6,NYLON	-
HN-03.5	4	NUT,HEX,3X.5MM,STL/ZNC	-
HW-03MM	4	LOCKWASHER,INT TOOTH,3MM,STL/ZNC	-
IC-0221	1	IC,RS232 DRIVER	U1
IC-0305	1	IC,NCP305LSQ45T1,RESET GENERATOR	U2
IC-0491	1	IC,QUAD OPAMP,SGL-SUP	U6
IC-9S12-256	1	IC,MC9S12A256BCPV	U3
IC-X005-HS	1	IC,HEX,INVTR,OPEN DRAIN,SM	U10
IC-X032-H	1	IC,SN74HC32N,QUAD OR	U4
IC-X138-S	1	IC,3:8LINE DECDR,SOIC	U7
IC-X573-HS	2	IC,OCT,D-TYPE,LATCH	U8,U9
IC-X574-S	1	IC,CD74HC574M,SOIC	U5
IR-8340	1	IC,REG,5V,1A,LDO,CMOS	U11
QA-0A13	1	TRANSISTOR,NPN,DAR	Q3
QA-3638	1	TRANSISTOR,PNP,.5A,25V	Q1
QA-5172	1	TRANSISTOR,NPN,100mA	Q2
QA-8099	1	TRANSISTOR,NPN,500mA	Q4
RA-0010	6	RESISTOR,10 OHMS	R15,R24,R26,R28,R32,R36
RA-0010-10	1	RESISTOR,10 OHMS	R29
RA-0047-20	1	RESISTOR,47 OHMS	R30
RA-0100	14	RESISTOR,100 OHMS	R13,R14,R43 thru R54
RA-0680	1	RESISTOR,680 OHMS	R18
RA-1000	3	RESISTOR,1K OHMS	R11,R21,R22

RA-3300	1	RESISTOR,3.3K OHMS	R33
RA-K010	5	RESISTOR,10K OHMS	R5 thru R7, R19,R20
RA-K012	2	RESISTOR,12K OHMS	R1,R3
RA-K033	1	RESISTOR,33K OHMS	R8
RA-K100	7	RESISTOR,100K OHMS	R2,R4,R37 thru R41
RA-K120	8	RESISTOR,120K OHMS	R9,R10,R12,R16,R17,R35, R42,R55
RB-4750	4	RESISTOR,4.75K OHMS	R23,R25,R31,R34
RB-K023	1	RESISTOR,23.7K OHMS	R27
RN-K120-7C	1	RES,NETWORK,120K OHMS	RP1
SL-0013	7	SWITCH,LIGHT TOUCH	SW1 thru SW7
SL-C013-01	7	SWITCH CAP,12X12	-
UB-2242	1	BUZZER,12VDC,13.7MM	CEP-2242
UC-1843	1	CRYSTAL,1.8432MHZ	Y1
UE-0004	2	FERRITE BEAD DOUBLE	B2,B3

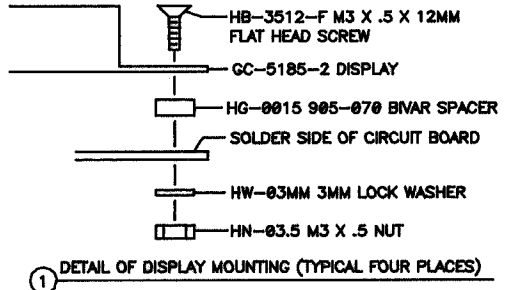
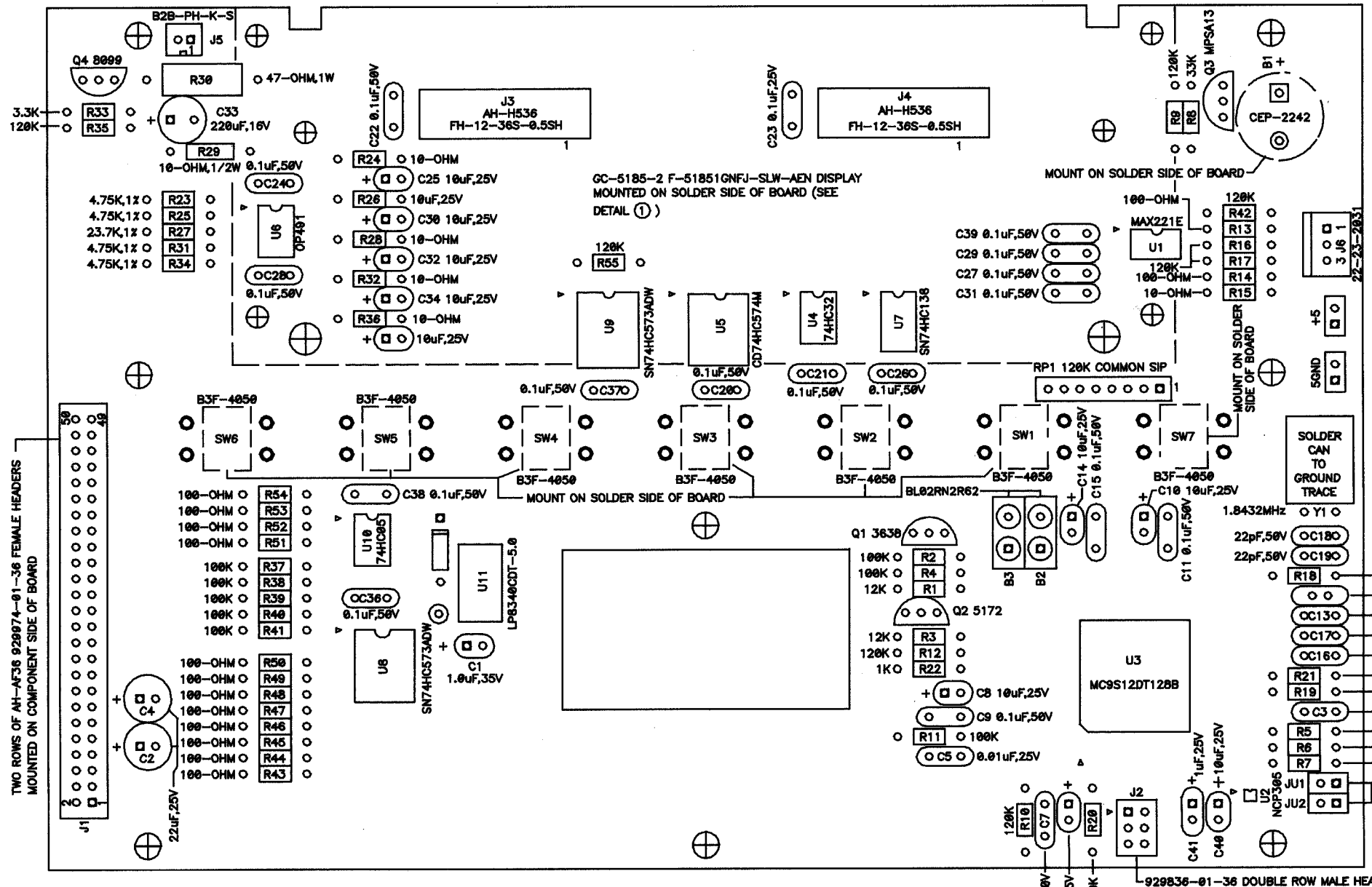

TWO ROWS OF AH-AF38 929874-01-36 FEMALE HEADERS MOUNTED ON COMPONENT SIDE OF BOARD

GENERAL NOTES:
 1. ALL LIGHT TOUCH SWITCHES ARE TO HAVE KEY TOPS (JPC PART NO. SL-C013-01).

MODEL	JU1	JU2
DA-2006	X	
DA-2006P		

X = JUMPER INSTALLED

BC GROUP DA-2006 (DT7395) AND DA-2006P (DT7396)
 DEFIBRILLATOR ANALYZER MICRO BOARD PARTS LAYOUT
 DWG NO. 21-739552-40-04
 DATE: 08/17/06
 PATH=E:\CC\DT7395\BC7395M4.PCB
 NOTE: USE DT7395 MICRO BOARD REV 4

Table 6: CIRCUIT BOARD DA-2006P – ANALOG

PART NUMBER	QUANTITY	DESCRIPTION	REFERENCE NUMBER
AH-AM36-1	0	HEADER,MALE,36PIN	JU1,JU2
AH-AM36-2	1.4	HEADER,MALE,36PIN	P1
AH-M002	1	HEADER,2PIN	J3
AH-M003	1	HEADER,3PIN	J2
AH-M102	1	HEADER,MOLEX,0.1CC,2PIN	J1
AI-CB40-02	1	HEADER,IDC,40PIN	J4
AM-0001	2	CONNECTOR,JUMPER,MIDGIE	JU1,JU2
AM-0006	11	LUG TEST POINT	TP1 thru TP11
BA-7395-A1	1	CKT BD,DT7395,ANALOG,REV4	-
CC-N001-90	3	CAP,.001uF,1KV,	C3,C13,C23
CC-N010-20	2	CAP,.01uF,25V	C29, C30
CC-N100-50	27	CAP,.1uF,50V	C2,C4,C7,C8,C9,C11,C12, C14 thru C19,C21 thru C28,C31,C33,C35,C44,C45, C47,C48
CC-P022-50	4	CAP,22pF,50V	C36 thru C38, C46
CC-P470-90	1	CAP,470pF,1000V	C1
CR-M220-10	1	CAP,220uF,16V	C43
CS-M001-50	1	CAP,1uF,50V	C20
CS-N010-50	1	CAP,.01uF,50V	C5
CS-N047-50	1	CAP,.47uF,50V	C6
CT-M001-20	4	CAP,1uF,25V DIPTAN	C10,C34,C40,C42
CT-M010-25	3	CAP,10uF,25V,TAN	C32,C39,C41
DA-4148	8	DIODE,1N4148,XXV,XA	CR1,CR2, CR8 thru CR13
DA-5817	3	DIODE,1N5817,20V1A	CR14 thru CR16
DZ-12CA	3	DIODE, P6KE12CA	CR3,CR5,CR7
HC-83/8-P	2	SCREW,8-32X3/8,PAN,PH,SS	-
HC-83/4-P	4	SCREW,8-32X3/4,PH,PAN,SS	-
HG-0013	2	SPACER ROUND,.100	-
HG-0018	16	SPACER,DONUT,.160	-
HN-L832	2	NUT,8-32,SS,W/NYLON INS LOCK	-
HP-7395-02	2	RESISTOR STANDOFF,7395	-
HW-S008	4	WASHER,#8,INT TOOTH,SS	-
HW-SF08	4	WASHER,#8,FLAT,SS	-
IC-0291-01	2	IC,DUAL OP AMP,OP291	U4,U7
IC-0491	4	IC,QUAD OPAMP,SGL-SUP	U1,U2,U5,U10
IC-1012-01	1	IC,OP AMP,PREC,UNIV,8-SONIC	U17
IC-4051	1	IC,4051,ANALOG	U8
IC-5841	2	IC,DRIVER,8-BIT,SERIAL INPUT	U11,U13
IC-7928	1	IC,A/D CONVTR,8CHANL	U14
IC-8043	2	IC,L/P,SERIAL,12BT,DAC	U3, U9
IR-0385	1	VOLT REG,LM385Z-2.5	CR6
IR-1761	1	IC,REGULATOR,+5V,LOW PWR	U15
IR-1964	1	IC,REGULATOR,-5V,LOW PWR	U16

MR-Z850	9	RELAY,AZ850P2-5.0	RL1 thru RL9
RA-0120	4	RESISTOR, 120 OHMS 1/4W 5%	R118 thru R121
RA-K100	1	RESISTOR,100K OHM	R40
RB-0010	1	RESISTOR, 10 OHM	R42
RB-0049-10	2	RESISTOR,49.9 OHM	R86,R89
RB-0100-10	1	RESISTOR,100 OHM	R93
RB-0201-10	1	RESISTOR,201 OHM	R98
RB-0237	1	RESISTOR,237 OHM	R37
RB-0410-20	1	RESISTOR,410 OHM	R103
RB-0499	1	RESISTOR,499 OHM	R75
RB-0825	3	RESISTOR,825 OHM	R74,R77,R79
RB-0827-30	1	RESISTOR,827 OHM	R116
RB-1000	1	RESISTOR,1K OHM	R117
RB-1500	2	RESISTOR,1.5K OHM	R73,R88
RB-1620	1	RESISTOR,1.62K OHM	R90
RB-1740	1	RESISTOR,1.74K OHM	R115
RB-2000	3	RESISTOR,2K OHM	R3,R7,R99
RB-3010	1	RESISTOR, 3.01K OHM	R123
RB-3320	1	RESISTOR,3.32K OHM	R5
RB-3380-30	2	RESISTOR,3.38K OHM	R114,R126
RB-3830-.1	2	RESISTOR,3.83K OHM	R104,R107
RB-3920	16	RESISTOR,3.92K OHM	R50 thru R57,R61 thru R68
RB-4750	3	RESISTOR,4.75K OHM	R91,R94,R95
RB-6810	2	RESISTOR,6.81K OHM	R72,R82
RB-8060	2	RESISTOR,8.06K OHM	R20,R34
RB-8250	1	RESISTOR,8.25K OHM	R35
RB-9090	1	RESISTOR,9.09K OHM	R9
RB-K003	1	RESISTOR,3.16K OHM	R48
RB-K005	2	RESISTOR,5.36K OHM	R39,R60
RB-K010	11	RESISTOR,10K OHM	R6,R8,R111,R112,R24,R45, R69,R83,R84,R85,R87
RB-K013	2	RESISTOR,13.3K OHM,1/4W,1%,MF	R11,R4
RB-K020	7	RESISTOR,20.0K OHM	R43,R46,R49,R58,R59,R101,R110
RB-K020-.1	2	RESISTOR,20K OHM	R105,R108
RB-K021	1	RESISTOR,21K OHM	R47
RB-K030	2	RESISTOR,30.1K OHM	R76,R78
RB-K039	1	RESISTOR,39.2K OHM	R21
RB-K047	1	RESISTOR,47.5K OHM	R23
RB-K062	2	RES,61.9K OHM,MTL	R38,R44
RB-K090	1	RESISTOR,90.9K OHM	R36
RB-K095	1	RESISTOR,95.3K OHM	R41
RB-K100	5	RESISTOR,100K OHM	R10,R96,R100,R122,R124
RB-K121	4	RESISTOR,121K OHM	R70,R71,R80,R81
RB-K249	16	RESISTOR,249K OHM	R12 thru R19,R26 thru R33
RB-K665	2	RESISTOR,665K OHM	R1,R2
RB-M002	1	RESISTOR, 2.0M	R92

RM-0050	2	POT,MULTI,50 OHM	RA5,RA6
RM-0500	1	POT, MULTI, 500 OHM, TOP ADJUST	RA3
RM-1000	2	POT,MULTI,1K OHM	RA2,RA4
RM-5000	1	POT,MULTI,5K OHM	RA1
RP-0025-01	2	RESISTOR,POWER,25 OHM	R22,R25
UA-S230	1	ARRESTER,SURGE,230V,2PIN	CR4
UE-0004	3	FERRITE BEAD DOUBLE	B1 thru B3
UE-0005	1	FERRITE SINGLE BEAD	B4

NOTE: Not all parts are used in every model. The Parts Layouts indicate parts that are not installed for particular models.

NOTES