

GOMCO MODEL 6053

● SUCTION APPARATUS SURGICAL HIGH VOLUME, LOW PRESSURE, PLEURAL CAVITY

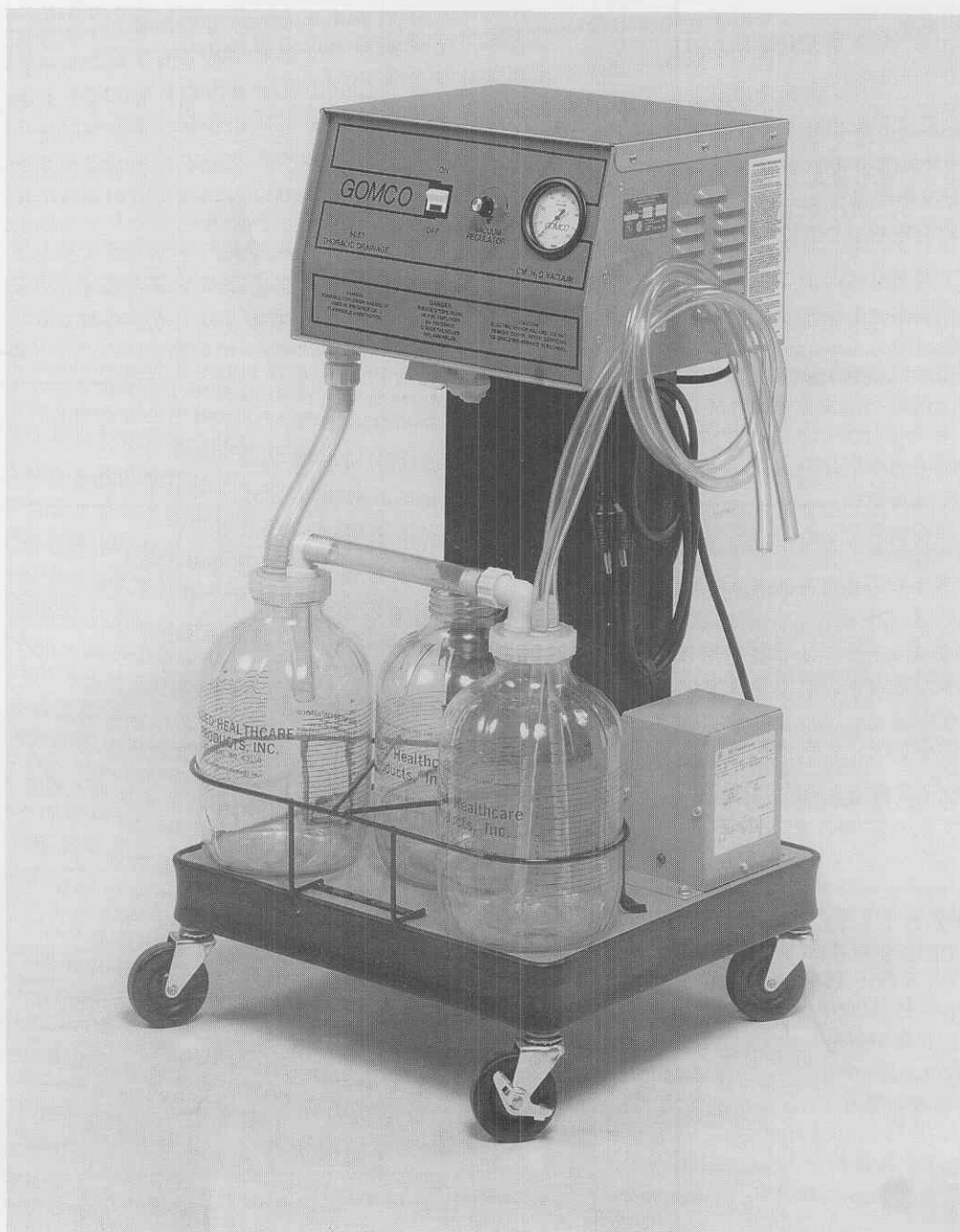

● OPERATION, MAINTENANCE AND SERVICE MANUAL

TABLE OF CONTENTS

1.0	Arrival Inspection Procedures	1
1.1	Unpacking	1
1.2	Inspection.....	1
2.0	General Information.....	1
2.1	Purpose.....	1
2.2	Features	1
2.3	Specifications	1
3.0	Equipment Set-Up	2
3.1	Collection Bottles and Tubing	2
4.0	Operation.....	2
4.1	Operating Procedure.....	2
4.2	Performance Checks	3
4.3	Precautions	3
4.4	Operator Troubleshooting	3
5.0	Care and Cleaning	3
5.1	Collection Bottles	4
5.2	Tubing	4
5.3	Stand Cleaning	4
5.4	Pump.....	4
6.0	Maintenance and Service	4
6.1	Installation.....	4
6.2	Principle of Operation	4
6.3	Maintenance and Repair.....	5
6.3.1	Test Equipment	5
6.3.2	Periodic Maintenance.....	5
6.3.3	Brush Replacement.....	5
6.3.4	Motor Replacement.....	6
6.3.5	Motor Fuse Replacement.....	6
6.3.6	Motor Control Replacement	7
6.3.7	Transformer Fuse Replacement.....	7
6.4	Major Troubleshooting	8
7.0	Storage.....	8
8.0	Illustrations	8
	No. 1 – Complete Assembly.....	9
	No. 2 – Collection Bottle System.....	10
	No. 3 – Patient Bottle Assembly	11
	No. 4 – Trap Bottle Assembly.....	12
	No. 5 – Motor (Pump) Assembly	13
	No. 6 – Schematic.....	14
	No. 7 – Front Control Panel.....	15
	No. 8 – Panel Assembly	16
	No. 9 – Step Down Transformer.....	17
9.0	Parts List and Accessories	18
10.0	Warranty	18
11.0	Copyright.....	18

1.0 ARRIVAL INSPECTION PROCEDURES:

1.1 Unpacking:

Remove pump from carton. Pump is completely assembled and ready for use. No set-up should be required.

Insure proper set-up by referring to Illustration Nos. 1 and 2 and cover photo.

Part No. 3099 is taped to the patient bottle. See Item 8 under 4.0 operation.

1.2 Inspection:

The unit should be visually checked for any apparent damage due to shipping, any broken or missing parts (refer to Illustration Nos. 1 and 2).

After a complete visual inspection performance checks should be run in accordance to 6.3.2 to confirm operation to specifications - 2.3.

2.0 GENERAL INFORMATION:

2.1 Purpose:

The Gomco Model 6053 is designed to re-establish vacuum within the pleural cavity following thoracic and cardiac surgery.

2.2 Features:

Supplied with the model 6053 as standard equipment are: (See Illustration No 1)

1. One (1) 2600 ml patient collection container with plastic top, and fittings and water seal tubes
2. One (1) 2600 ml trap collection container with plastic top and fittings
3. One (1) 2600 ml spare collection container
4. All connecting tubing and patient tubes
5. Compact cart with non-marking casters (2 with brakes), easy to clean stainless steel top, illuminated on-off switch, easy reading 0 to 76 cmH₂O vacuum gauge and vacuum regulator
6. A step-down transformer enabling the use of Model 6053 in areas supplied with 230 volts.
7. Cooling fan intergal within pump to allow for extended running without excessive heat build up
8. Night light and electrical receptacle built into the bottom of the cabinet.

2.3 Specifications:

1. Vacuum Range:
0 to 60 cmH₂O
2. Flow Rate:
Open Flow 130 LPM
3. Electrical Requirements:
115/230 Volts 50/60 Hz 2.5 AMP
4. Motor and Pump Description:
Two stage, by pass vacuum motor single phase, 220 volt 50/60 Hz
5. Dimensions:
(D) 17" x (W) 18" x (H) 33-1/4"
6. Weight:
Shipping - 78 lbs.
Net 71 lbs.
7. Variable transformer (Vac. Regulator):
0 to 120 Volt Output

3.0 EQUIPMENT SET-UP:

3.1 Collection Bottles and Tubing:

After cleaning (Section 5.0), the equipment should be set-up as follows:

3.1.1 Patient Collection bottle: (See Illustration No. 3)

1. Install water seal tubes (2) into lid as shown in Illustration No. 3.
2. Screw cap securely onto collection bottle.

3.1.2 Trap Collection Bottle: (See Illustration No. 4)

1. Install splash tube into fitting on underside of lid as shown in Illustration No. 4.
2. Screw cap securely onto collection bottle.

3.1.3 Tubing: (See Illustration No. 2)

1. All tubing should be connected as shown in Illustration No. 2.
2. Place bottle system into bottle bracket on pump base and connect the bottle to pump tube to the underside of the cabinet as shown in Illustration No. 1.

4.0 OPERATION:

4.1 Operating Procedure:

1. Fill the "patient bottle" with sterile water to the 2 cm mark on the graduated water seal tubes.
2. Be sure all tubing and bottle tops are tight.
3. The power switch (See Illustration No. 7) on the front panel should be in the "Off" position.
4. The voltage supply (115V 50-60 Hz or 230V 50-60 Hz) of the room that the suction apparatus is to be used in must be determined. For 115 volt use, the power cord extending down from the left corner of the stand body (parallel bladed plug) should be plugged directly into the 115 volt receptacle. For 230 use, plug the power cord extending down from the left corner of the stand body (parallel bladed plug) into the transformer receptacle at the rear of the stand base. Plug the power cord extending out of the opposite end of the transformer (straight bladed plug) into the 230 volt receptacle. See Figure No. 1.

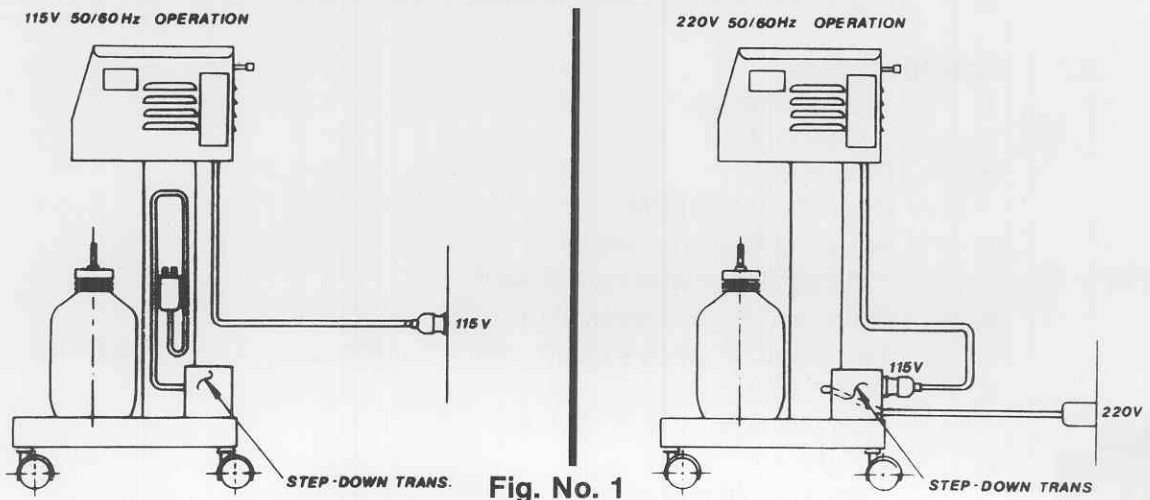

5. Bottles and tubing should be in place and connected as per Illustration Nos. 1 and 2.
6. Turn the power switch to the "On" position. The light in the switch indicates the power is on.

7. Turn the regulator knob clockwise to increase the vacuum level, counter-clockwise to decrease the vacuum level. Bubbling should be noticed in the bottle with the water seal. (See III. No. 7).
8. With the pump running, pinch off the two (2) patient tubes and adjust the vacuum level to the desired amount. (This setting will be the maximum vacuum). If only one patient tube is used, the unused fitting in the patient bottle top should be capped-off with part no. 3099.
9. Your thoracic pump is now ready for patient use.
NOTE: Pleural vacuum is determined by subtracting the pressure head of the water seal from the vacuum indicated on the gauge.
EXAMPLE: The reading on the gauge (cm H₂O) equals the approximate negative pressure available.

4.2 Performance Checks:

To insure proper pump performance, the operator should periodically check the following:

1. Occlude patient tubing - set vacuum - release patient tubing and occlude to make sure set vacuum level is attained.
2. Check regulator function by increasing and decreasing regulator and observing the corresponding increase and decrease on the vacuum gauge.

4.3 Precautions:

1. **DANGER:**
A possible explosion hazard exists if this apparatus is used in the presence of flammable anesthetics.
2. **CAUTION:**
Electric shock hazard, do not remove the stainless steel top cover of this unit. Refer servicing to qualified service personnel.
3. **CAUTION:**
When patient collection bottle fills to the last graduation of the bottle, it should be emptied or changed.

4.4 Operator Troubleshooting:

PROBLEM	PROBABLE CAUSE:	REMEDY:
PUMP WILL NOT RUN WHEN SWITCH IS "ON"	BAD POWER SOURCE	CHECK PLUG
LOW VACUUM	LOOSE TUBING OR BOTTLE CAPS	CHECK TUBING AND BOTTLE CAPS

NOTE:

In the event this unit is not performing as intended, and all the probable causes and remedies as described in 4.4 have been eliminated, refer any further servicing to qualified personnel. This work should be performed by a qualified bio-medical technician or other qualified technical personnel familiar with repair practices for servicing medical devices.

5.0 CARE AND CLEANING:

With proper care this equipment will provide trouble free operation for many years. The following are procedures which should be followed when the equipment is removed from a patient:

5.1 **Collection Bottle Cleaning:**

1. Unscrew the bottle top assemblies from the bottles.
2. Dispose of drainage fluids in the bottles.
3. Soak the bottles and bottle top assemblies in a warm detergent solution.
4. Wash all the parts with a warm detergent solution and a nylon bristle brush, rinse thoroughly with water and aerate.
 - A. Autoclave at 250°F with autoclave timer set for 15 minutes. Follow autoclave manufacturer's directions for recommended procedure.
CAUTION: Do not flash autoclave the collection bottles.
 - B. If desired, sterilize with ethylene oxide gas. Follow manufacturer's directions for recommended procedure.

5.2 **Tubing, Cleaning & Sterilization:**

1. Remove tubing from fittings
2. Soak in warm detergent solution
3. Wash all parts with a warm detergent solution and a nylon bristle brush, rinse thoroughly with water and aerate.
 - A. Autoclave at 250°F with autoclave timer set for 15 minutes. Follow autoclave manufacturer's directions for recommended procedure.
CAUTION: Do not flash autoclave.
 - B. If desired, sterilize with ethylene oxide gas. Follow manufacturer's directions for recommended procedure.

5.3 **Stand Cleaning:**

The entire stand should be disinfected after patient use by wiping it down with a mild disinfecting detergent. Mix the detergent according to the recommended manufacturer's directions.

5.4 **Pump:**

1. **Lubrication:**
The motor and pump are permanently lubricated and require no further oiling or greasing.
2. **Cleaning:**
See section 6.3.2 periodic maintenance.

6.0 **MAINTENACE AND SERVICE:**

6.1 **Installation:**

The unit should be unpacked and inspected per 1.0 of this manual.

1. Insure set-up is proper (See 3.0).
2. Unit operates on 115/230 volt 50/60 Hz. See 4.1, Item 4 for proper voltage set-up.

6.2 **Principle of Operation:**

The operation of the unit is simple and centers around a two-stage vacuum motor. Vacuum is regulated by a variable Transformer (regulator), See Illustration No. 6 and No. 8, which controls the speed of the pump. To increase the vacuum the regulator knob is turned clockwise which increases the voltage to the pump. This in turn increases the RPM of the pump which increases the vacuum. Decreasing the voltage lowers the RPM of the pump which decreases the vacuum. This unit is capable of running on both 115 or 230 volt 50/60 Hz power by using the step down transformer on the base. (See Figure No. 1 under 4.0 operation for proper set-up for voltage available.) When using 115 volt or 230 volt, the variable transformer, night light, switch and any other electrical components in the cabinet will only see 115 volts because when 230 volt power is used to operate the equipment, the transformer on the base reduces the voltage to the equipment to 115 volts.

6.3 Maintenance and Repair:

6.3.1 Test equipment:

Test equipment which will be required to perform periodic maintenance and tests is as follows:

1. Multimeter for checking resistance (OHMS) and voltage
2. cm H₂O manometer or vacuum gauge calibrated in cm H₂O for checking vacuum

6.3.2 Periodic Maintenance:

To insure proper pump performance the following checks should be made by qualified service personnel every three (3) months at a minimum while pump is in use.

1. Clean inside of cabinet and bleed hole
2. Check brushes
3. Ground continuity
4. Vacuum level
5. Transformer function

6.3.2.1 Cabinet Cleaning:

Disconnect unit from power source and remove stainless steel top. With a small vacuum cleaner or dusting rag, remove any dust build-up on or around vacuum motor and exhaust fan. Check air bleed hole in motor mounting ring to be sure it is free of all obstructions to allow proper air flow through the pump. (See Illustration No. 5)

6.3.2.2 Brushes:

While the power is disconnected and the top is off, the two (2) brushes should be checked to insure sufficient life. They should be changed (See 6.3.3) before the brush shunt touches the communicator.

6.3.2.3 Ground Continuity:

Ground continuity between the chassis and the plug ground pin should be checked to assure operator and patient safety. Power cord replacement or tightening the chassis ground screw will usually rectify an interrupted ground.

Necessary instrument: OHM meter or HY-POT tester

6.3.2.4 Vacuum Level:

Vacuum levels should be checked to insure proper performance. Attach vacuum gauge or manometer to patient tubing and check that reading on test gauge and gauge on unit correspond to ± 2 graduations.

Necessary equipment: Vacuum guage or water manometer.

6.3.2.5 Step down transformer function:

Plug transformer into a 230 volt power source and check output voltage at the receptacle on the back of the transformer. Output should be 115V with a 230 volt input. If no output voltage is recorded, check the fuse adjacent to the receptacle.

Necessary equipment: Multimeter to check voltage.

6.3.3 Brush Replacement:

1. Always disconnect the power supply prior to servicing.
2. Remove stainless steel top.

3. Remove the two (2) wires from the brush holders by tapping with a screwdriver. (See figure No. 2)
4. Remove the two (2) screws and bracket holding the brush assembly in place (both sides) and remove brush assemblies.
5. Insert the male spade terminal into the opening of the replacement brush assembly (both brushes).
6. Place brush assemblies on motor frame so that the locating pin of the brush assembly is seated into its pocket.
7. Replace brush holder brackets and tighten screws.
8. New brushes must be seated on the commutator to achieve best performance.

Seating for new brushes:

After new brushes are installed per the replacement procedure 6.3.3, they must be properly seated on the commutator as follows.

Procedure: after brush change turn unit on and turn regulator fully clockwise (MAX) and run for 30 minutes to accomplish seating.

WARNING: During this seating procedure the vacuum inlet must not be sealed off.

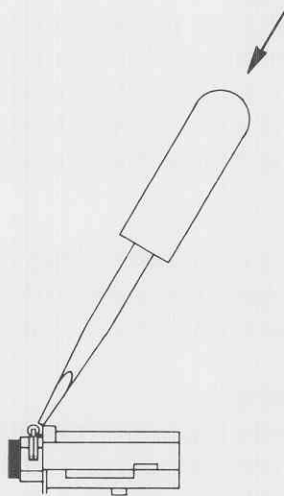

Fig. No. 2

6.3.4 Motor Replacement: (Refer to Ill. No. 5)

1. Disconnect the power supply prior to servicing.
2. Remove stainless steel top cover.
3. Remove four 10-32 nuts and lockwashers from bottom of cabinet.
4. Disconnect wires from variable transformer.
5. Disconnect all tubing from mounting ring.
6. Remove pump assembly from cabinet.
7. Remove the four 10-32 nuts and lockwashers from the lower end of the hold down brackets (See Illustration No. 5).
8. Motor will now come free of the mounting ring and plate.
9. Remove the four self-tapping screws holding the hold down brackets to the motor and remove brackets.
10. Install 2390 gasket to bottom of new motor and install 1/4" female quick connect terminals to both pump wires.
11. Install the four hold down brackets to the new motor with the four self-tapping screws.

12. Center plastic mounting ring on mounting plate and install motor with the four 10-32 x 3/4 screws, nuts and lockwashers making sure the motor is firmly seated on ring and plate.
13. Install complete assembly into cabinet. Connect tubing and wires.
14. Brushes will have to be seated because this is a new motor. After assembly, refer to 6.3.3 for brush seating procedure. This must be accomplished before equipment is placed into service.
15. After seating brushes, perform the periodic maintenance checks to insure proper function.

6.3.5 **Motor Fuse Replacement:**

1. Disconnect power supply
2. Remove stainless steel top
3. Unscrew fuse cap located on the side of the motor
4. Discard blown fuse and insert a new fuse rated 2.0 amp slow-blow
5. Screw the fuse cap back on
6. Replace stainless steel top
7. Perform the checks under periodic maintenance 6.3.2 to insure proper function

CAUTION: THIS SHOULD ALWAYS BE DONE BY QUALIFIED PERSONNEL

6.3.6 **Motor Control Replacement:**

1. Disconnect power supply.
2. Remove stainless steel top.
3. Remove knob from variable transformer with 1/16 allen wrench.
4. Remove all wires from variable transformer.
5. Remove mounting nut from front of unit.
6. Remove variable transformer.
7. Install new transformer making sure the 3/16 diameter boss enters the hole in the front panel.
8. Install mounting nut and knob.
9. Install wires.
10. Perform the checks under a periodic maintenance to insure proper function.

6.3.7 **Transformer Fuse Replacement:**

1. Disconnect the unit from its 230 volt power source.
2. Unscrew the fuse cap located on the transformer.
3. Discard the blown fuse and insert a new fuse rated 1.5 amp Type AGC
4. Screw the fuse cap onto the transformer.

6.4 Trouble Shooting:

PROBLEM	PROBABLE CAUSE	REMEDY
PUMP WILL NOT RUN WHEN SWITCH IS ON	1. BAD POWER SOURCE	CHECK PLUG
	2. LOOSE OR DISCONNECTED WIRES	CHECK WIRING ILL. NO. 6
	3. BAD VARIABLE TRANSFORMER	CHECK INPUT & OUTPUT OF VARIABLE TRANSFORMER ILL. NO. 6
	4. BAD BRUSHES ON MOTOR	CHECK AND REPLACE BRUSHES 6.3.2.2 & 6.3.3
	5. BAD MOTOR	REPLACE 6.3.4
	6. BAD SWITCH	CHECK SWITCH
	7. TRANSFORMER FUSE BLOWN	REPLACE 6.3.7
	8. MOTOR FUSE BLOWN	REPLACE 6.3.5
LOW VACUUM	1. LOOSE TUBING OR BOTTLE CAPS	CHECK ALL CONNECTIONS
	2. BRUSHES NOT SEATED ON NEW MOTOR OR BRUSHES	SET BRUSHES 6.3.3
	3. LOW VOLTAGE	CHECK POWER SUPPLY

7.0 STORAGE:

Gomco Model 6053 is designed for indoor use and should be stored in facilities similar to the hospital environment. Sheltered from weather, the recommended storage conditions are 0° to 120°F for temperature and a maximum limit of 90% humidity. Maintenance checks as specified in paragraph 6.3.2 should be made before pump is placed in use.

8.0 ILLUSTRATIONS:

No. 1 — Complete Assembly	09
No. 2 — Collection Bottle System	10
No. 3 — Patient Bottle Assembly	11
No. 4 — Trap Bottle Assembly	12
No. 5 — Motor (Pump) Assembly	13
No. 6 — Schematic	14
No. 7 — Front Control Panel	15
No. 8 — Panel Assembly	16
No. 9 — Step Down Transformer	17

DESIGN 7-92	DATE 28 1/82	GOMCO Division Allied Healthcare Products, Inc.	818 East Ferry Street Burlingame, CA 94010	REV. NO. M-3973
WLB	WLB			PART NO. 01-36 6053
TITLE BILL OF MATERIALS FOR THE MANUFACTURE OF BILL OF MATERIALS		DRAWN BY LINDA ASSBY		PROJ. NO. 6053

BILL OF MATERIALS

REF No.	QTY.	DESCRIPTION	PART No.
1	1	ST. STL. TOP COVER	2573
2	7	PLATED POP RIVET	2604-2
3	6	#8-3/8 ST. SCR. TYPE 1	
4	1	OPERATION DECAL	3967
5	1	STAND ASSY	3971
6	1	FRONT PANEL ASSY	3963
7	1	SIDE FORM	3434
8	1	BOTTOM FOAM	3447
9	1	NYLON ADAPTOR	2531
10	1	NYLON SAWV6	2532
11	1	BOTTLE TO PUMP TUBE	3970
12	1	SPARE BOTTLE	3105
13	1	BOTTLE TO BOTTLE TUBE	3968
14	1	TRAP BOTTLE ASSY	2521
15	1	BOTTLE BRACKET	3958
16	4	GROMMET	2241
17	4	#10 FLATWASHER	
18	7	#10 LOCKWASHER	
19	7	#10-32 HEX NUT	
20	1	NIGHT LIGHT TWRP	3966
21	1	HEXCO STRAIN RELIEF	2028-2
22	5	#10-32x 1/2 RO. HO. M.S.	
23	1	PATIENT BOTTLE ASSY	5102
24	1	POWER CORD 115V.	2737
25	1	GROUND TAG	2940-2
26	1	PUMP ASSY	5151
27	1	PUMP TO GAUGE TUBE	2797
28	1	FUSE DECAL TRANS.	5125
29	1	NAMEPLATE	3972
30	1	TRANSFORMER DECAL	3941
31	1	PUMP CONN. TUBE	3006
32	1	STEP DOWN TRANS.	5159
33	4	1/4-20x 1/2 W/LC Lox SCR.	
34	4	1/4" LOCKWASHER	
35	4	1/4-20 HEX NUT	
36	1	NYLON ELBOW	3004
37	4	BLACK POP RIVET	2604-1
38	1	OUTLET ASSY	3969
39	2	PATIENT TUBE 4 FT.	2535
40	2	#8-32x 1/6 RO. HO. M.S.	
41	2	#8 LOCKWASHER	
42	2	#8-32 HEX NUT	
43	2	PATIENT TUBE CAP	3099
44	1	FUSE DECAL IN LINE	5177

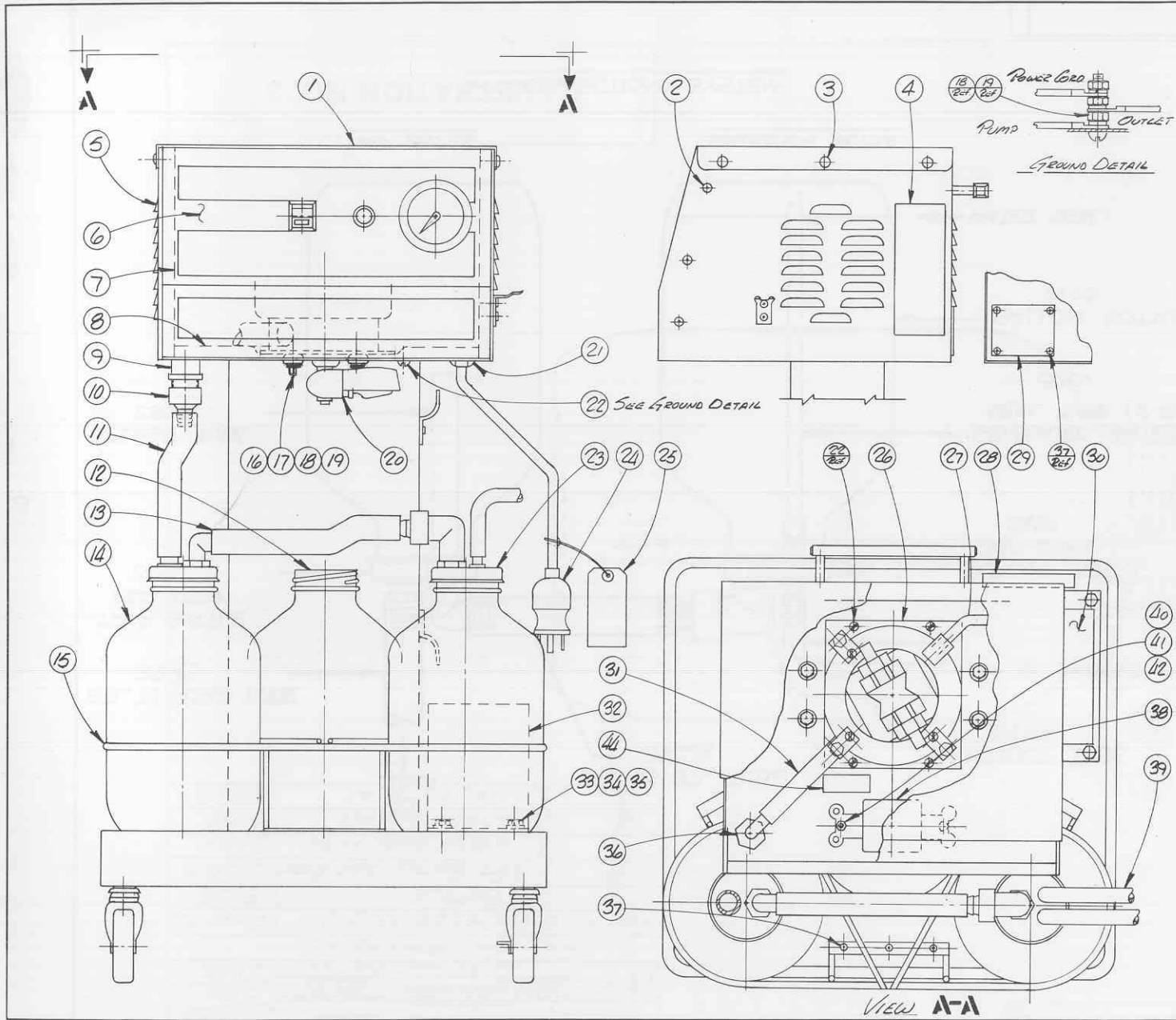
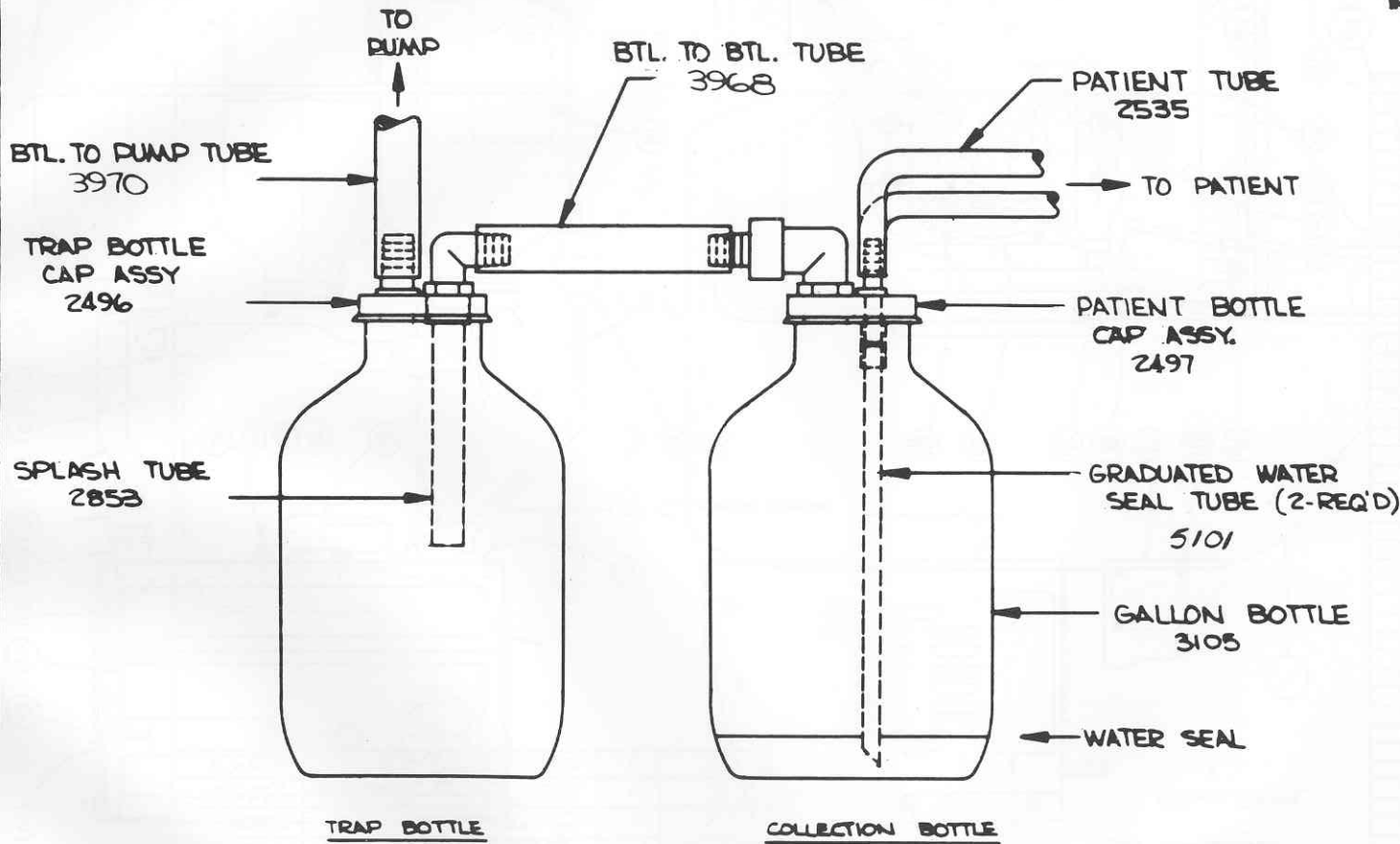

ILLUSTRATION NO. 1

COLLECTION BOTTLE ASSY - 5102
 INCLUDES: GALLON BOTTLE - 3105
 PATIENT BTL CAP ASSY - 2497
 2-WATER SEAL TUBES - 5101

TRAP BOTTLE ASSY - 2521
 INCLUDES: GALLON BOTTLE - 3025
 TRAP BTL CAP ASSY - 2496
 SPLASH TUBE - 2853



6053 COLLECTION SYSTEM

10

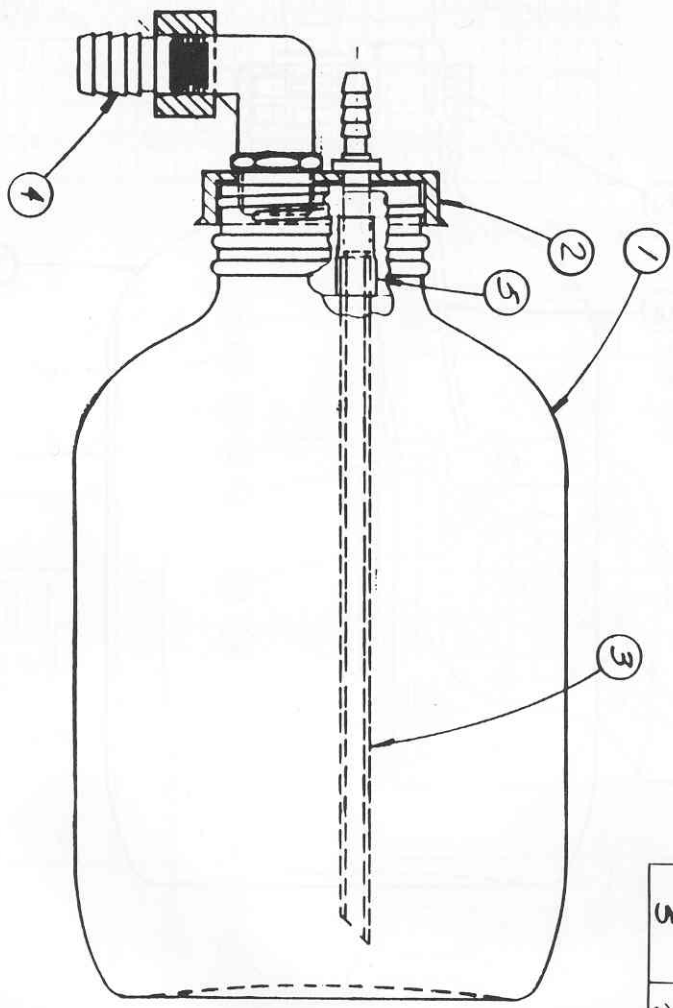

GOMCO Division		3102-A	
3102			
6053			
<i>BILL OF MATERIALS</i>			
Part No	Qty	Description	Part No
1	1	BOTTLE	3105
2	1	TOP ASSY	2497
3	2	WATER SEAL TUBE	5101
4	1	NYLON SWIVEL	2532
5	2	SOLICE TUBE	2822

ILLUSTRATION NO. 3

GOMCO Division		2521-A
TRAD BOTTLE ASSY		2521
BILL OF MATERIALS		4053
QTY	DESCRIPTION	PART NO
1	BOTTLE	3105
1	TRAD BOTTLE TOP ASSY	2496
1	SPRUSH TUBE	2053

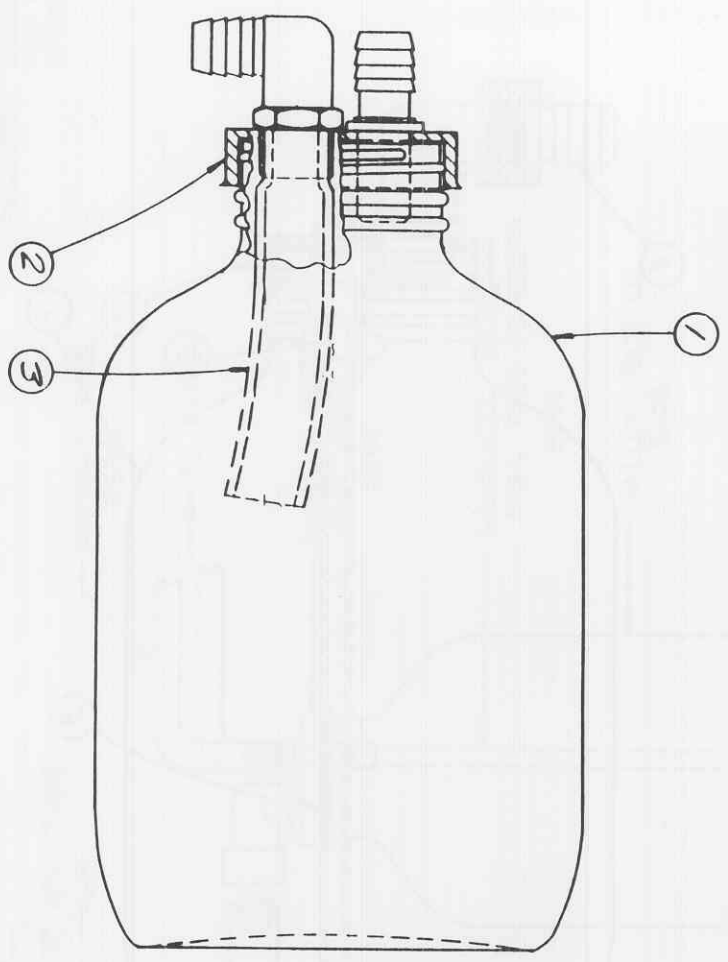
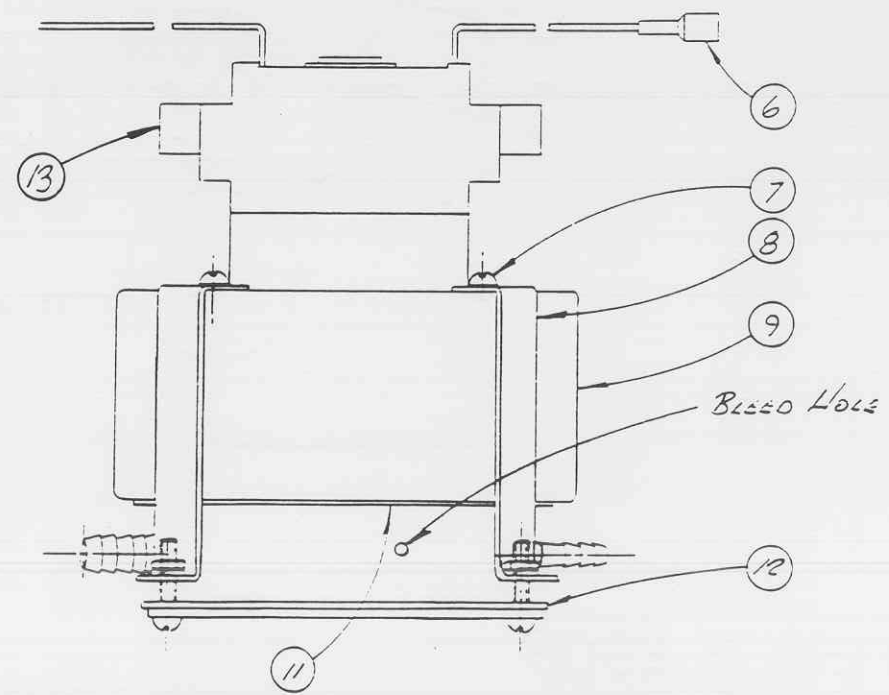
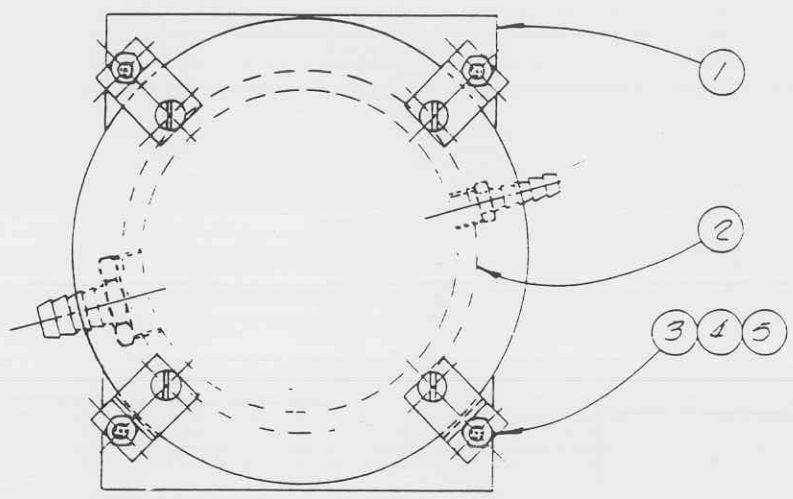

ILLUSTRATION NO. 4



FORM 5-21	CHECKED	GOMCO SURGICAL MFG. CORP.	5151-A
5151	DATE	SEE PARTS LIST SUPPLIED WITH THIS DRAWING	
Full	These drawings and specifications are the property of GOMCO SURGICAL MFG. CORP. and shall not be copied, reproduced, or used in any way without the written consent of GOMCO SURGICAL MFG. CORP.		5151
FILE NO.	NAME	ITEM NO.	QTY.
	Pump Assy		6050
BILL OF MATERIALS			
REF. No.	QTY.	DESCRIPTION	PART No.
1	1	PLATE	3388
2	1	RING ASSY	2528
3	6	#10-32-30 LG	PO. NO. M.S.
4	4	#10-32 HEX NUT	
5	4	#10 LOCKWASHER	
6	1	INSUL. SLIP ON (RES)	2339-L
7	4	SELF TAP #10-32	
8	1	HOLD DOWN BEET.	3471
9	1	MOTOR	5176
11	1	GASKET	2390
12	1	GASKET	2538
13	1	REPLACEMENT BRUSH	3569

ILLUSTRATION NO. 5

6053 SCHEMATIC

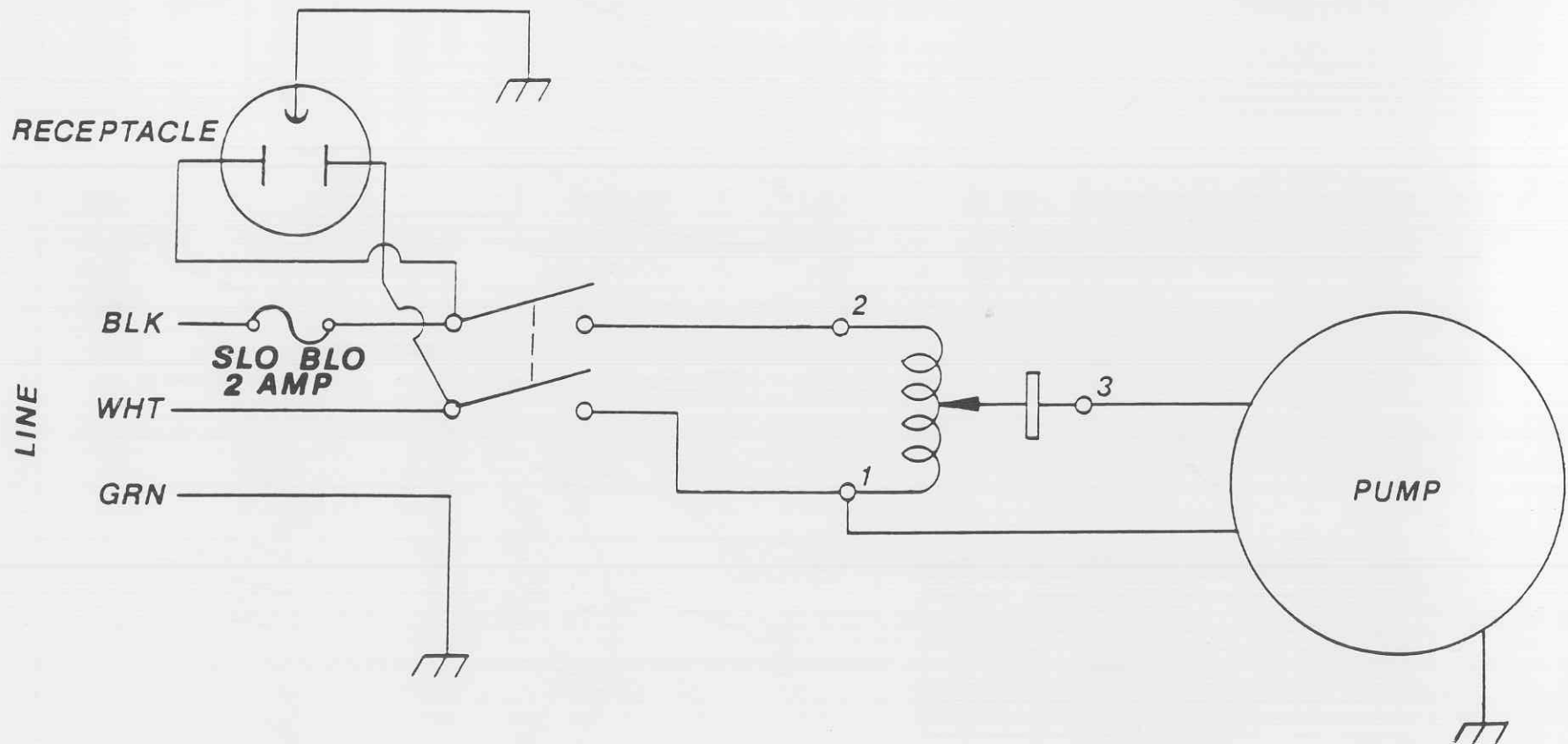

DATE 8-87	REVISED COP	GOMCO Division	200 East Park Street Burlingame, CA 94010	REV. BY
PART NO.		FRONT PANEL RESY		6053
BILL OF MATERIALS				
ITEM NO.	QTY	DESCRIPTION	PART NO.	
1	1	FRONT PANEL	5121	
2	1	ON-OFF SWITCH	2904	
3	1	VACUUM REGULATOR	3961	
4	1	VACUUM GAGE	2518	

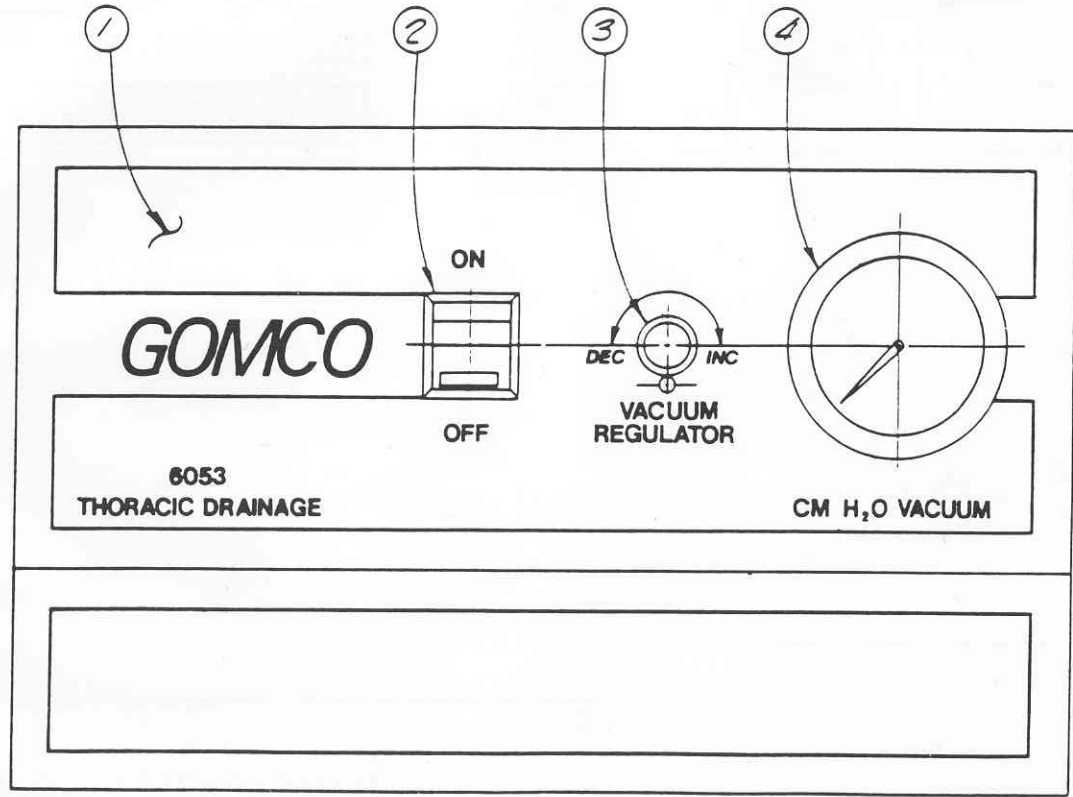
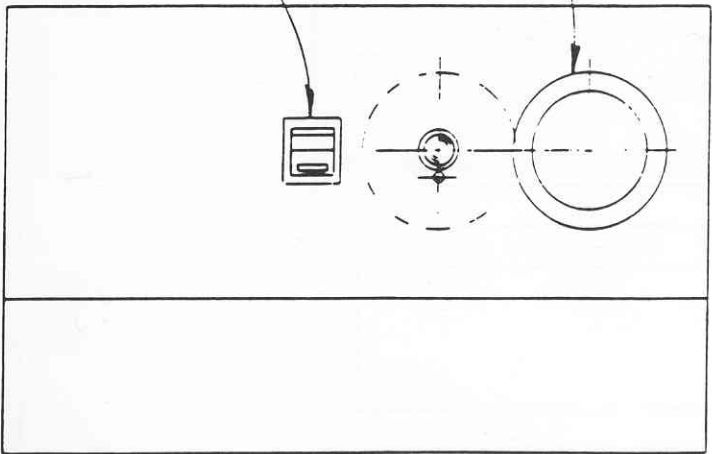
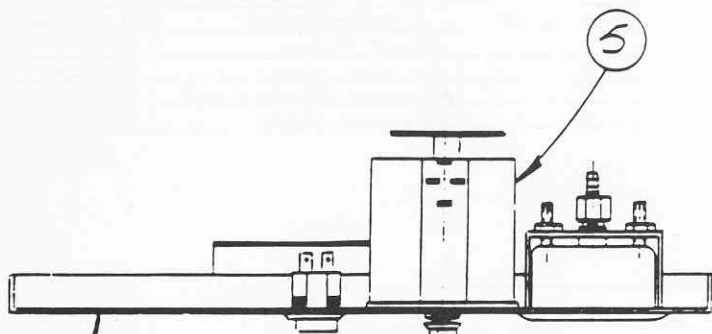

ILLUSTRATION NO. 7



DATE 8-67	DESIGNED CAD	ENGINEER EGER APP	GOMCO Division Allied Healthcare Products, Inc.	EST. L&M FORM 5100 Sullivan, NY 14211	DWG. NO. 8-3963 SA
SMALL Hole			THIS DRAWING AND SPECIFICATIONS ARE THE PROPERTY OF GOMCO AND SHALL NOT BE REPRODUCED, COPIED OR USED AS THE BASIS FOR THE MANUFACTURE OR SALE OF APPARATUS WITHOUT PERMISSION	FOR OTHER USES WITHOUT PERMISSION SECTION 1 OF FRONT PANEL 1102 ANALOG 1102	PART NO. 3963
FILE NO.	NAME FRONT PANEL ASSY.			SIZE 7/8 6053 GOUT	

BILL OF MATERIALS			
ITEM No	QTY.	DESCRIPTION	PART No
1	1	FRONT PANEL	3181
2	1	ON-OFF SWITCH	2306
3	1	KNOB	2951
4	1	GAGE ASSY	2518
5	1	MOTOR CONTROL (VARIAL)	3961

REVISIONS

ILLUSTRATION NO. 8

CHG. LTR.	CHG. NO.	DATE	BY

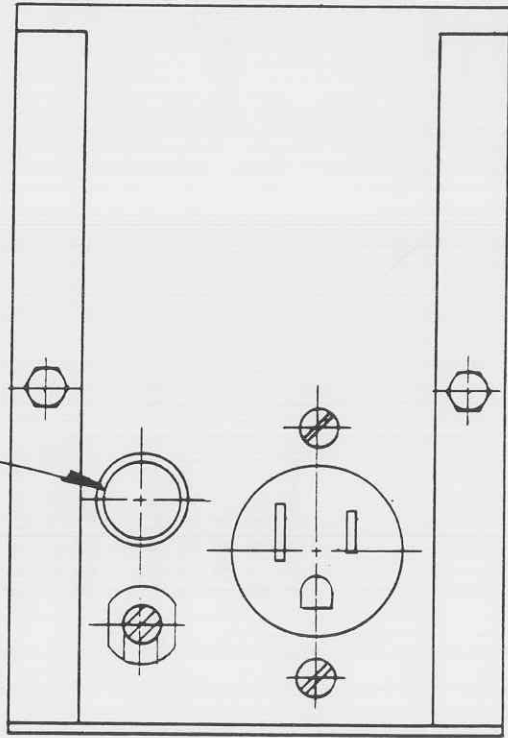

FUSE 1.5 AMP
TYPE AGC
PART No. 5062

STEP-DOWN TRANS.
PART No. 5159

ILLUSTRATION NO. 9

9.0**PARTS LIST AND ACCESSORIES****ILL. NO.**

01-90-5102	Patient Bottle Assembly	3
Collection Bottle	01-90-3105	2,3
Patient Bottle Top Assy.	01-90-2497	2,3
Water Seal Tube	01-90-5101	2,3
Nylon Swivel	01-90-2532	3
01-90-2521	Trap Bottle Assembly	4
Collection Bottle	01-90-3105	2,4
Trap Bottle Top Assy.	01-90-2496	2,4
Splash Tube	01-90-2853	2,4
01-90-5151	Pump Assembly	5
Motor	01-90-5176	5
Ring	01-90-2528	5
Motor Gasket	01-90-2390	5
Ring Gasket	01-90-2538	5
01-90-3963	Front Panel Assembly	8
On-Off Switch	01-90-2304	8
Variable Transformer	01-90-3961	8
Gauge	01-90-2518	8
Knob	01-90-2351	8
01-90-2535	Patient Tube	
01-90-3970	Bottle to Pump Tube	
01-90-3968	Bottle to Bottle Tube	
01-90-2737	Power Cord	
01-90-3958	Bottle Bracket	
01-90-5159	Step Down Transformer	
01-90-3966	Night Light	
01-90-5062	Transformer Fuse	
01-90-5175	Pump Fuse	

10.0 WARRANTY:

The seller warrants that the products manufactured by the seller are free from defects in material and workmanship for a period of one (1) year after receipt.

11.0 COPYRIGHT:

The drawings and specifications in this manual shall not be reproduced, copied, or used as the basis for the manufacture of this apparatus. Copyright is limited to the U.S. Government for use in military services training programs and other technical publications.

***Allied Healthcare
Products, Inc.***

GOMCO Division

1720 Sublette Avenue
St. Louis, MO 63110
Telephone: (314) 771-2400
Toll Free: (800) 444-3954

INSTRUMENTS OF CARE