

# Dornoch

Medical Systems, Inc.

## Transposal Ultra Evacuation Unit Technical Manual



Model No.: UL-EV100







# Contents

Introduction	1
Important Information	2
Intended Use	2
Equipment Description	2
User/Patient Safety	3
Technical Description	4
Specifications	4
Operation	6
Safety Features	7
Environmental Protection	7
Waste Disposal Accessories	7
MSDS Sheet for Bleach and Enzyme	7
Reusable Suction Reservoir Use and Processing	8
Instructions for Use	9
Processing Reservoirs	9
Reprocessing Reservoirs (Optional)	9
Prepare Cart for Next Case	9
Replacing Bleach & Enzyme Bottles	10
Reprocessing Cycle Descriptions:	10
Performing Verify Bleach Cycle:	10
Unit Information and Error Messages	11
Periodic Maintenance	11
Troubleshooting Guide	12
DMS Technical Service - Information	12
Symbols & Labels	13
Consumables and Accessories	14
Use of Single Use Lids and Manifolds	14
Installation	15
Protective Packaging & Unpacking	15
Site Preparation	15
Utilities Needed for Installation	16
Space	16
Water Supply	16
Electrical	16
Sanitary Sewer (Drain)	16
Backflow Preventers	16
De-install/Disconnect Instructions	18
Equipment Storage	18
Maintenance	19
Qualifications for Service Personnel	19
Service Warnings	19
Additional Information	19
Routine Maintenance	20
Replacement Items	20

Fluid Paths and Wiring Diagrams-----	21
Preventative Maintenance -----	25
Company Information -----	26
Contact Information -----	26
Limited Warranty -----	27

### List of Tables

Table 1 – Equipment Specifications.....	4
Table 2 – Site Utilities for Installation.....	16
Table 3 – Preventative Maintenance Schedule .....	25

### List of Figures

Figure 1 – Ultra Evac Unit Dimensions and Features (Dim.=inch(cm))-----	5
Figure 2 – TP-DL2800 Single Use Lid-----	6
Figure 3 – UL-CL500 Single Use Manifold-----	6
Figure 4 – Ultra Fluid Cart Connected to the Ultra Evac Unit-----	6
Figure 5 – Coupler Insertion -----	9
Figure 6 – Cycle Complete Screen -----	9
Figure 7 – Cleaning Cycles Screen -----	9
Figure 8 – Bleach and Enzyme Bottles -----	10
Figure 9 – Ultra Evac Unit Architectural Drawing-----	17
Figure 10 – Environmental Conditions-----	18
Figure 11 – Ultra Evac Unit Fluid Flow Diagram -----	21
Figure 12 – Ultra Evac Unit Wiring Diagram-----	22
Figure 13 – Ultra Evac Unit Board Schematic -----	24

# Introduction

The Transposal Ultra Evacuation Unit (evac) is designed to empty, clean, and rinse the Ultra Fluid Carts (carts). The evac is used to process the Ultra Quad Cart (4 reservoirs) and the Ultra Duo Cart (2 reservoirs) after they have been used to collect fluids in the surgical procedure.

Two manuals are provided with this equipment and are shipped with the equipment during the initial installation. Copies of these manuals are available to any Dornoch Medical Systems, Inc. (DMS) customer upon request.

The two different manuals are as follows:

Instructions for Use Manual – This manual is designed to instruct users in the correct operation of the evac as well as safety considerations associated with the unit.

Technical Service Manual – This manual includes operation instructions, installation & disconnection instructions, technical specifications, and preventative maintenance procedures for the unit.

This is the Technical Service Manual, and it is broken into seven sections including:

- *Introduction*
- *Technical Description*
- *Operation*
- *Installation*
- *Maintenance*
- *Company Information*
- *Limited Warranty*

As a supplement to these two manuals, instructional video(s) are available to assist maintenance personnel in their understanding of the equipment's operation and the maintenance procedures needed. If required, DMS service personnel can be contacted 24-hours a day at 1-888-466-6633.

# Important Information

Please read this manual and follow all instructions. The words WARNING, CAUTION and NOTE have special meanings and should be reviewed.

**WARNING:** Disregarding WARNING information may compromise the safety of the patient and/or health care staff and may result in injury.

**CAUTION:** Disregarding CAUTION instructions may compromise product reliability and may result in damage.

**NOTE:** NOTE information supplements and/or clarifies procedural information.



A triangle with an exclamation point alerts the health care professional to read and understand the accompanying instructions, especially the operating, maintenance and safety information.

## Intended Use

The intended use of the evac is to process the carts after they have collected surgical fluids. The evac will empty, clean, and rinse the reusable suction reservoirs on the carts.

## Equipment Description

The evac is a standalone unit that can automatically process a cart. The evac empties, cleans, and rinses the carts during the process. The Ultra System significantly reduces employee exposure to potentially infectious body fluids, while eliminating up to 70% of Operating Room red bag waste.

The evac processes Ultra Duo and Ultra Quad carts for reuse. Once installed, operators simply connect the evac to a dirty cart with the evac's coupler. With a touch of a button the cart is automatically emptied, cleaned, and rinsed. With the addition of a new single use lid, they are ready for reuse within the facility.

# User/Patient Safety



## WARNINGS:

- Before using this system, read and understand the information in this manual.
- DO NOT use this system outside the scope of the defined indications for use.
- Upon initial receipt and before each use, operate the equipment and inspect each component for damage. DO NOT use any component if damage is apparent.
- Handling biohazard waste is potentially dangerous. ALWAYS follow current local regulations governing biohazard waste to safely handle and dispose of surgical fluid waste.
- The Blood-borne Pathogens Standards, provided by the Occupational Safety and Health Association (OSHA), requires that all workers, having exposure to “potentially infectious materials”, should wear the correct personal protection equipment.
- To avoid the risk of electrical shock, this equipment must be connected to electrical outlet with a protective earth ground.
- Verify all access doors are securely in place before operating this unit.
- Use only Dornoch Medical Systems, Inc. approved accessories. Do not connect items to this system that are not designed for or specified for use with this system.
- Perform recommended maintenance as indicated in these instructions. Only trained and experienced health care professionals should maintain this equipment.
- No user serviceable parts inside the unit. Contact Dornoch Medical Systems, Inc. customer service if an issue arises. Only authorized service personnel should open any of the access covers on this equipment. User operation does not require access to these areas.
- ALWAYS use the handle to move the cart. DO NOT push or pull the cart by grasping any receptacle or the outer surface. NEVER hang any heavy object from the cart handles.
- ALWAYS have more than one person unpack and lift the equipment off the shipping pallet.
- No incline planes of operation.
- DO NOT use the system if leakage of surgical fluid waste occurs. Disconnect power immediately and call Dornoch Medical Systems, Inc. customer service.
- DO NOT allow fluid of any kind to spill directly onto the exterior surface of the electrically-powered evac.
- DO NOT use the evac until it has been installed and tested for proper operation.
- This unit uses both bleach and enzyme in its operation. When replacing bottles, always wear the appropriate Personal Protective Equipment. Use only Dornoch Medical Systems, Inc. approved Bleach and Enzyme to avoid damage to the system components.
- This equipment is not suitable for use in the presence of flammable anesthetic mixtures with air, oxygen or nitrous oxide. Is not intended for use with AP or APG equipment.
- Hot Water Temperatures higher than 118 °F can cause damage to the unit.
- There are no known significant risks of reciprocal interference posed by the presence of this equipment or its operation in either the operating room suites or other areas when used during specific investigations and/or treatments.
- There are no known potential electromagnetic or other interferences between this unit and other devices located and/or operated within the area of the operating room suites.

# Technical Description

## Specifications

**Table 1 – Equipment Specifications**

Item	Ultra Evac Unit (#UL-EV100)
<b>Certifications</b>	ETL Listing - Class 1 Medical Device. Complies with the following: <ul style="list-style-type: none"> <li>▪ IEC-60601-1: General Requirements for Safety</li> <li>▪ IEC-60601-1-1: Safety Requirements for Medical Electrical Systems</li> <li>▪ IEC-60601-1-2: Electromagnetic Compatibility - Requirements and Tests</li> <li>▪ IEC- 60529 rating certification of IP41</li> <li>▪ FDA 510K certification</li> <li>▪ CAN/CSA Standard C22.2 No. 601.1</li> </ul>
<b>FDA Registration</b>	# 1954182
<b>Patents</b>	Patent Pending
<b>Installation</b>	Fixed
<b>Size (inch (cm))</b>	20(51)W x 16(41)D x 28(71)H
<b>Weight (lbs (kg))</b>	100(46)

### Utilities

<b>Power</b>	120VAC, 60Hz, 15amp
<b>Water</b>	3/4" Hot and Cold, 5.0gpm(18.9lpm), 55psi Hot Water Temperature 100 – 115°F (38 - 46°C)
<b>Drain</b>	1 ½" – 2"
<b>Space (inch (cm))</b>	24(61)W x 20(51)D x 33(84)H
<b>Additional Cooling</b>	None
<b>Flammable Rating</b>	Not suitable for use in the presence of flammable anesthetic mixture with air or with oxygen or with nitrous oxide.

### Operation

<b>Mode</b>	Continuous
<b>Cycle</b>	5 to 16 minutes
<b>Water Use</b>	5.0(18.9) to 10.0(37.9) gallons(liters)/cycle
<b>Enzyme Use</b>	5.8(172) to 10.8(319) ounces(milliliters)/cycle
<b>Bleach Use</b>	2.85(84) to 5.7(168) ounces(milliliters)/cycle
<b>Cleaning</b>	Dornoch enzyme solution and Clorox bleach are used to clean the collection cylinders of the Ultra Fluid Cart.

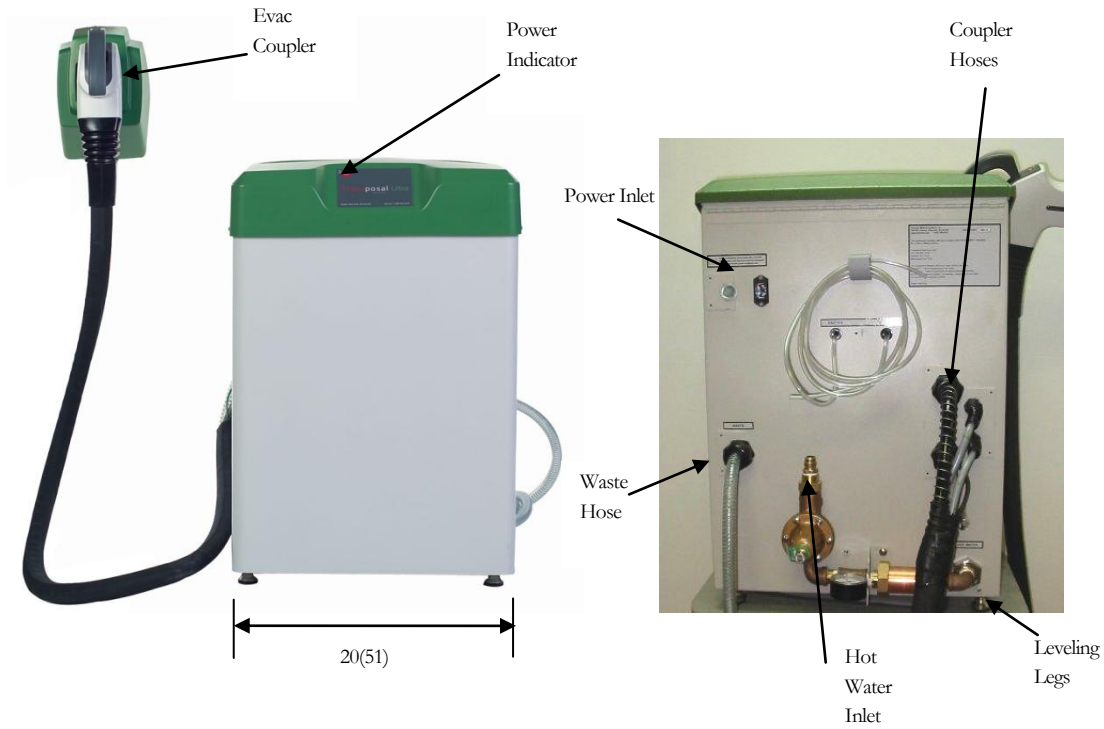

**Figure 1 – Ultra Evac Unit Dimensions and Features (Dim.=inch(cm))**

# Operation

The Transposal Ultra Infectious Fluid Management System consists of carts for fluid collection and the evac for fluid disposal. Carts collect up to 52 liters of surgical fluids without the need to tandem multiple suction canisters. In addition, each Ultra unit's on-board vacuum pump replaces or improves facility wall vacuum performance when inadequate suction is otherwise present.

Once connected to a 120 VAC electrical outlet, cart reservoirs collect fluids from one to three separate sites. Ultra Duo Fluid Carts have two 16.5 liter reservoirs and Ultra Quad Fluid Carts have four 13.0 liter reservoirs. Reservoirs can be used with wall vacuum and/or the on-board vacuum pump.

A single use lid (Figure 2) or manifold (Figure 3) is used to make suction tube connections from the field to the cart. The Ultra Duo uses two single use lids or manifolds and the Ultra Quad uses four lids or manifolds. New lids are pressed on to the top of cart reservoirs or new manifolds are inserted into the housings. On carts with the single use lid, only one sealed, cleaned reservoir is used per patient. Carts are removed from the OR suite for processing after all reservoirs have been used, or at the end of the day. On carts with the single use cart manifold, the manifold is changed between patients to allow for multi-patient fluid collection. The carts are removed for processing at the end of every day.

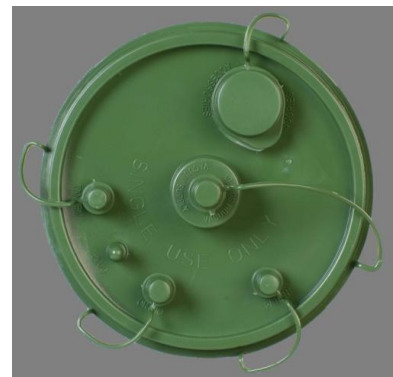

**Figure 2** – TP-DL2800 Single Use Lid



**Figure 3** – UL-CL500 Single Use Manifold

Cart processing is accomplished with an evac (Figure 4) located in an OR utility closet or decontamination room. Evacs empty, clean, and rinse reservoirs for reuse. The evac's water, drain, and sensor lines are easily connected to the cart using a drip-less all-in-one coupler connection. Carts are powered by the evac coupler connection during reservoir processing.



**Figure 4** – Ultra Fluid Cart Connected to the Ultra Evac Unit

## Safety Features

The Ultra Fluid Carts have numerous built in safety features including:

- **Closed System Design.** The Ultra Fluid Carts are designed to confine and contain fluids during disposal. Personnel never open cylinders that contain collected fluids.
- **Interactive Controls.** The Ultra Fluid Carts' high-tech control system guides users through unit operation while monitoring key functions.
- **Bleach Cycle Monitoring.** Continuous automatic monitoring of the bleach cycle is accomplished with electronic sensors within the Ultra Evac Unit.

## Environmental Protection

**Infectious Waste:** None

## Waste Disposal Accessories

There are no current accessories required for disposal from this unit.

## MSDS Sheet for Bleach and Enzyme

MSDS sheets are available upon request by calling DMS at 1-888-466-6633.

# Reusable Suction Reservoir Use and Processing

- **Reservoir Processing.**



**WARNING:** Follow the current local regulations governing biohazard waste to safely handle and dispose of surgical fluid waste.

Carts should be processed when all of the collection reservoirs have been used or at the end of the day. Designated OR, SPD, or housekeeping personnel shall empty and clean used carts with the evac. Processing shall be accomplished in accordance with manufacturer's directions. After processing, wipe down the cart with a hospital approved bleach wipe (Sani-Cloth Bleach Germicidal Wipe (DMS# UL-BW100), Clorox: Germicidal Wipes or equivalent) and place clean lids onto the cart. Non-approved wipes may cause surface damage to the equipment.

- **Bleach Verification.** Daily visual verification of the cart/evac systems bleach cycle shall be completed using a Verification Log Kit (#TP-VL100). Continuous automatic monitoring of the bleach cycle is accomplished with electronic sensors within the evac. If an error is detected, the message shall be reported to an immediate supervisor.
- **Single Use Items Storage.** A supply of new single use reservoir lids or manifolds shall be kept in a designated clean storage area, and near any point of use.
- **Preparing Reservoirs for Use.** A new single use lid (TP-DL2800) or manifold (UL-CL500) shall be placed onto the reservoir in a designated clean area. The user must verify the white hydrophobic filter is in place on the lid or manifold. If it is the first case of the day or the cart has just been processed, verify the reservoirs are clean prior to installing a new single use lid.
- **Cart Cleaning.** Ultra Fluid Carts should be processed when all of the collection reservoirs have been used or at the end of the day.
- **Cart Transportation.** Used carts shall be sealed and transported to the evac for processing. Before processing the cart, verify all of the ports on the single use lids or manifolds are capped.

# Instructions for Use

## Processing Reservoirs

**Step 1** – Insert the coupler into the receiver and gently press the handle down. (Figure 5)

**Step 2** – Verify that all reservoirs have green lids/manifolds and that all of the ports are capped.

**CAUTION:** Caps must be on all ports prior to washing to prevent wash fluid from leaking out onto the top of the cart during processing.

**Step 3** – Follow the on-screen instructions to start the processing cycle.

**Step 4** – When processing is complete (Figure 6), verify the reservoirs are clean. If reservoirs are not clean, proceed to the Reprocessing Reservoirs instructions below.

**Step 5** – Press the “REMOVE COUPLER” button and remove the coupler by first pressing down gently on the handle and then lifting up while pulling the coupler out of the receiver. Place the receiver in the storage unit.

**CAUTION:** ALWAYS press down gently on the handle prior to removing the coupler. Failure to do so could cause damage to the equipment.

## Reprocessing Reservoirs (Optional)

**Step 1** - Access the reprocessing options by pressing the “OPTIONS” button in the upper right corner. (Figure 6)

**Step 2** - Select the desired reservoir(s) and the cleaning cycle and then press the “START PROCESS” button to perform the selected cycle. (Figure 7) **See “Reprocessing Cycle Descriptions”.**

## Prepare Cart for Next Case

**Step 1** – Remove the used lids/manifolds from each reservoir and discard according to hospital policy. Processed lids/manifolds can be identified with a blue filter.

**Step 2** – Wipe down the cart with a hospital approved bleach wipe. (Sani-Cloth Bleach Germicidal Wipe (DMS# UL-BW100), Clorox: Germicidal Wipes or equivalent)

**Step 3** – Move the cart to a clean area and replace the lids/manifolds.



**Figure 5** – Coupler Insertion

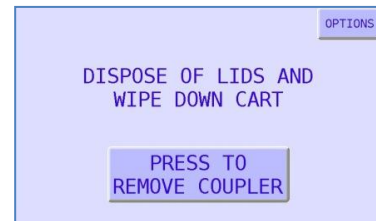

**Figure 6** – Cycle Complete Screen



**Figure 7** – Cleaning Cycles Screen

## Replacing Bleach & Enzyme Bottles

Evac Station bleach and enzyme bottles must be replaced when indicated on the cart's display during processing. Bottle replacement is completed as follows:

**CAUTION:** ALWAYS use approved enzymatic cleaner and fresh Clorox bleach when replacing chemicals (Clorox bleach slowly loses strength over time). Other chemicals may damage the evac and cart.



**Figure 8** – Bleach and Enzyme Bottles

**Step 1** – Remove lid and pickup tube from empty container. (Figure 8)

**Step 2** – Open a new bottle, place the bottle into the top of the unit, insert the pickup tube into the bottle, and secure the lid.

**Step 3** – Dispose of the empty bottle per hospital policy.

## Reprocessing Cycle Descriptions:

**3L Soak** – Cycle applies 10 ounces of enzyme with 3 liters of water to help break up any clots that may be remaining in the bottom of the reservoir at the end of the cycle. Let the fluid soak for at least one hour for best results.

**Full Soak** – Cycle fills reservoir to the 13L (Quad) or 16.5L (Duo) mark along with about 10 ounces of enzyme. This cycle is used if there are spots on the reservoir that are not coming off during a wash. Let the fluid soak for at least one hour for best results.

**Rewash** – Cycle will attempt to clean the selected reservoir(s) again using wash water and enzyme. The cycle will apply the solution and pause several times during the rewash cycle.

## Performing Verify Bleach Cycle:

To verify that the unit is applying bleach, place the unit into the check for bleach mode by using the following steps:

1. Hook a cart to the evac.
2. Press the button to confirm the lids are on the reservoirs.
3. On the second screen press the options button in the upper right hand corner.
4. Select "Bleach Check" and press the "Start Process" button.
5. The cart will process through bleach application and will give instructions on the screen.
6. Remove a test strip from its container.
7. Remove the lids and touch one end of the test strip to a droplet on the bottom of the first lid and use the other end of the test strip to touch a droplet on the bottom of the other lid.
8. A purple test strip indicates a pass. Any other color indicates a failed result.
9. Replace the lids onto the reservoirs and press the button on the screen to complete processing.
10. If the test strip turns purple the canisters are having bleach applied to them.
11. If the test strips do not turn purple, call DMS at 1-888-466-6633 and ask for service.

## Unit Information and Error Messages

The cart display provides the operator feedback for common operating errors encountered during the evac processing cycle. The most common messages are described below. Please call DMS at 1-888-466-6633 for assistance with any error message.

<b>Warning or Error</b>	<b>Action Required</b>
<b>Leak Detected:</b> This message indicates that there has been a leak detected within the evac. The unit alarms at the end of the cycle when cart has completed the cleaning process.	Check all supply lines for correct connection. Call service if necessary.
<b>Replace Bleach:</b> This message indicates that the unit has run out of bleach. The unit alarms at the end of the cycle and when replaced will go back and apply bleach to the reservoirs as necessary.	Replace the bleach with a new gallon.
<b>Replace Enzyme:</b> This message indicates that the Enzyme solution has run out. The unit alarms at the end of the cycle when the reservoirs have completed the cleaning process.	Replace the enzyme with a new gallon.
<b>Valve Error:</b> This message indicates one of the evac valves is not operating properly. The error displays after the reservoirs have completed the cleaning process.	Contact service with the specific valve error.
<b>Communication Error:</b> This error indicates that the cart and the evac are hooked together but there is no data transfer between the two.	Uncouple the evac from the cart. Wipe the contacts on the coupler and in the receiver with alcohol and try to hook them together again. Call service if the problem continues.

## Periodic Maintenance

### **Interval**                      **Activity**

Prior to each use	Inspect the coupler hose for twisting or any leaks in the hoses. Inspect the coupler housing for any cracks or other defects that may affect function. DO NOT use if the equipment if damage is present.
As required	Check the level of the enzyme and bleach in the bottles. Replace the bottles as required.

## Troubleshooting Guide

### **Problem: Unit Will Not Operate**

#### **Possible Solutions:**

1. Check that the machine is plugged into an operational outlet.
2. Call maintenance to replace the Unit's internal fuses.

### **Problem: Coupler Engages but Cart Will Not Power Up**

#### **Possible Solutions:**

1. Remove the coupler and try again.
2. Clean the electrical contacts with a cotton swab and alcohol. Try to activate the cart again.
3. Call DMS at 1-888-466-6633.

### **Problem: Chemical Flow Error Even With New Gallons**

#### **Possible Solutions:**

1. Tighten connections on the pickup tubes in the chemical bottles.
2. Clean chemical pickup tubes in warm water.
3. Call DMS at 1-888-466-6633.

### **Problem: Reservoirs are Not Washing**

#### **Possible Solution:**

1. Verify the water to the unit is turned on.
2. Check for any crimps in the black water line to the coupler on the back of the evac.
3. Call DMS at 1-888-466-6633.

## DMS Technical Service - Information

DMS Technical Service is available 24 hours a day, 7 days a week. Technicians are available in the office from Monday – Friday from 8AM until 5PM central standard time. DMS uses a paging system for any calls received at other times during the day and will get back with you as soon as possible. Please call 1-888-466-6633 and have the information below available for the technician. If possible, call with the equipment available for troubleshooting.

- Equipment Type (Ultra Duo, Ultra Quad, Evac or Safety Station)
- Equipment Serial Number
- Description of the problem
- Location of the equipment
- Contact information for a service technician coming to the account

## Symbols & Labels

The explanation and location of all Labels, Safety Signs, Symbols and Displays used on the equipment is presented below.

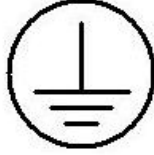

**Protective Earth Ground Symbol** – This label is used to symbolize a protective earth ground location on the unit. There is one located on the ground from the main power cord and another located on the ground for the 24VDC power supply. There is also one located on the ground wire from the coupler.



**Functional Earth Ground Symbol** – This label is used to symbolize a functional earth ground. They are located near all functional grounds.

**Electrical Requirements and Serial Number Label** - Located on the back of the unit upper right corner (as facing the back). Information contained on this label: Dornoch contact information, serial number, ETL compliance information, electrical information and patent information.

Dornoch Medical Systems, Inc. 200 NW Parkway Riverside, MO 64150 <a href="http://www.dornoch.com">www.dornoch.com</a> (888) 466-6633	Serial Number <input type="text"/>
This equipment complies with and is Listed under the IEC-60601-1 (2 <sup>nd</sup> Edition) Standard for a Class 1 Medical Device.	
Ultra Transposal Evacuation Unit 115 – 120 VAC 60 Hz Nominal 0.2 – 6.0 A Momentary Peak 8.8 A	
This equipment complies with and is approved for use under: IEC-60601-1: General Requirements for Safety IEC-60601-1-1: Safety Requirements for Medical Electrical Systems IEC-60601-1-2: Electromagnetic Compatibility - Requirements and Tests IEC-60529 rating certification of IP41	
Patent Pending	

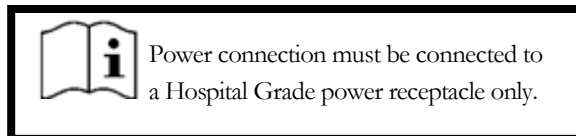

**Operating Instructions** – Located on the back of unit near the power cord. The label is used to instruct the user to the manuals as well as inform them of the power outlet requirements of the unit.



**Waste Label** – This label is used to identify the waste line where it exits the rear of the unit. This label is located next to the waste line on the rear of the unit.

**HOT WATER**

**ENZYME**

**BLEACH**

**Hot Water Label** – This label is used to identify the hot water line where it enters the rear of the unit. This label is located next to the water line on the rear of the unit.

**Enzyme Label** – This label is used to identify the inlet location of the enzyme line. This label is located next to the enzyme line on the rear of the unit.

**Bleach Label** – This label is used to identify the inlet location of the bleach line. This label is located next to the bleach line on the rear of the unit.

## Consumables and Accessories

The following is a list of consumables associated with the evac.



**WARNING:** Use only Dornoch-approved components and enzyme. DO NOT modify any component or accessory.

- UL-EZ200 – Enzymatic Cleaner
- TP-VL100 – Verification Log and Test Strips for Bleach Application Verification
- UL-BW100 – Sani-Cloth Bleach Germicidal Wipe – approved surface disinfectant wipe for the carts.
- Clorox Bleach

## Use of Single Use Lids and Manifolds



**WARNING:** Both the TP-DL2800 lid and the UL-CL500 manifold are designed to be used for a single patient. Failure to change the item after each patient may result in the following:

1. Loss of available suction. Contaminated and/or wet filters will affect vacuum flow.
2. Cross contamination. Improper usage of single use items poses a health risk to patients and health care providers.

# Installation

## Protective Packaging & Unpacking



**WARNING:** ALWAYS have more than one person unpack and lift the evac off the shipping pallet.

Special measures are needed for and during transport of the unit. Ultra Evac Units are equipped with four adjustable legs. Ultra Evac Units should be put on a cart or dolly for transporting during installation/de-installation. Adjustable legs are adjusted to level the unit during installation.

To obtain information on transporting and temporary storage considerations call DMS at 1-888-466-6633.

Premature unpacking of the Ultra Evac Units could risk damage to or loss of the installation items that may be sent with the unit. Contact customer service if unpacking the unit is necessary.

## Site Preparation

A DMS Installation Technician is responsible for the physical hook-up, on-site quality control testing and the initial start up of Ultra Evac Unit equipment. Customers are responsible for preparing the equipment space and utilities at the installation site.

All equipment sites must be prepared in accordance with the requirements described here at least seven (7) days prior to scheduled system installation.

This section outlines the general and specific site preparation requirements for space, water, drain, and electrical needs are presented below. Figure 9 presents an architectural drawing of site requirements. Please use these figures as a reference for proper site preparation.

## Utilities Needed for Installation

**Table 2 – Site Utilities for Installation**

<b>Power</b>	120VAC, 60Hz, 15amp
<b>Water Supply</b>	3/4" Hot and Cold, 5.0gpm(18.9lpm), 55psi
<b>Water Temperature</b>	100 – 115°F (38 - 46 °C)
<b>Drain</b>	1 ½" – 2"
<b>Space</b>	24(61)W x 20(51)D x 33(84)H

### Space

The Ultra Evac Unit installation site must be a minimum of 24" (61cm) W x 20" (51cm) D x 33" (84cm) H. The Ultra Evac Unit must be installed no less than 6 inches (15cm) from the wall to accommodate operator access to the unit's main power supply wall outlet.

### Water Supply

The Ultra Evac Unit requires a hot water supply running at a minimum of 5.0gpm (18.9lpm) and 55psi. Hot water temperature should be between 100-115°F (38 - 46 °C). Hard water in excess of 5.0 grains per gallon can adversely affect equipment operation. Consequently, hard water must be treated before it enters installed equipment. Untreated hard water supplies will void equipment warranties.

A 3/4" supply is desirable because of the volume of water it carries, but a 1/2" line is usually sufficient as long as the facility has good water pressure (55 psi or higher at the unit). Hot supply pipe should run up or down the wall to the left side of the space where the machine will be installed, ending 48" (122cm) to 58" (148cm) from the floor. Attach a threaded ½" FPT ball valve to the end of the supply pipe.

### Electrical

The unit's electrical supply must be within 36" (92cm) of the unit location. A ground fault receptacle rated at 120 VAC, single phase at 60 Hz and 15 amps is required. The Ultra Evac Unit draws a peak current of 8.8 amps with a normal operating current draw of 0.2 to 6.0 amps.

### Sanitary Sewer (Drain)

The Ultra Evac Unit requires a 1-1/2" to 2" PVC or copper sanitary sewer drain connection. The ideal drain is centered on the install site, 6" (15cm) to 15" (38cm) from the floor and has an attached trap. The drain can protrude vertically out of the floor or horizontally from the wall. Drainpipes brought up through the floor should stay as close as possible to the wall. Wall drains should not protrude more than 6" (15cm) from the wall. The drain shall be trapped and have a 16" (40cm) long standpipe.

A mop sink or hopper may be used in lieu of the above specification.

### Backflow Preventers

The Backflow preventer is integrated into the Ultra Evac Unit. It requires no drain hook-up. Consult local regulations for specific requirements.

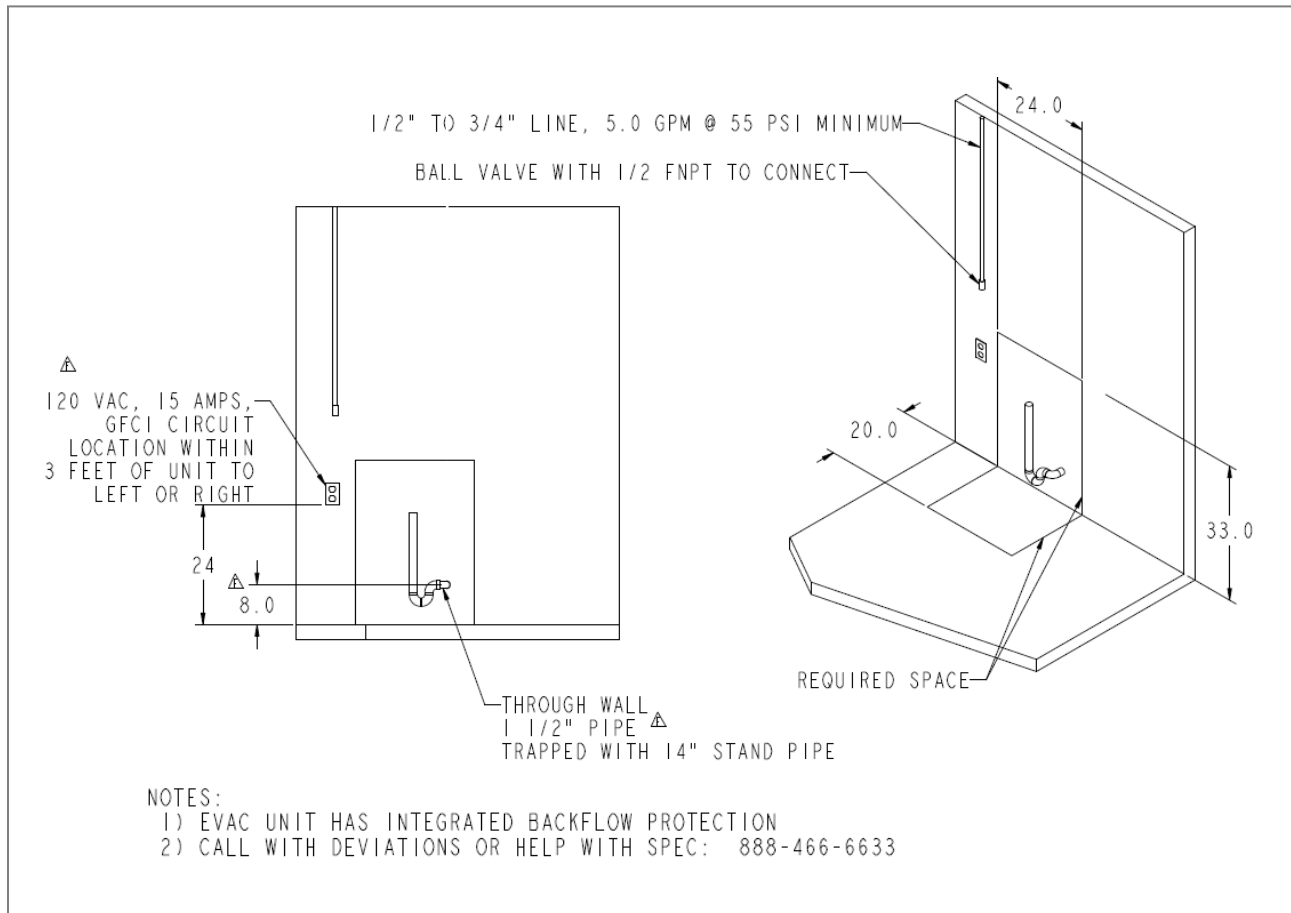

**Figure 9** – Ultra Evac Unit Architectural Drawing

# De-install/Disconnect Instructions

Please contact DMS at 1-888-466-6633 prior to de-installation or re-installation of an evac.

If a Customer de-installs or re-installs an evac, the guidelines listed below must be followed.

- Always wear personal protective equipment (PPE), including eye protection and latex gloves, to prevent contact with potentially infectious material.
- Always unplug the unit from the wall electrical receptacle before moving equipment.
- Wipe down the unit with an approved contact disinfectant after each use.

## Equipment Storage

Temperature range for proper storage is -20°C to 40°C. If unit is to be taken out of service and stored for a prolonged period of time, evacuate water from the hot and cold water manifolds, as well as removing the bleach and enzyme solution from their chemical tanks regardless of temperature within storage facility.

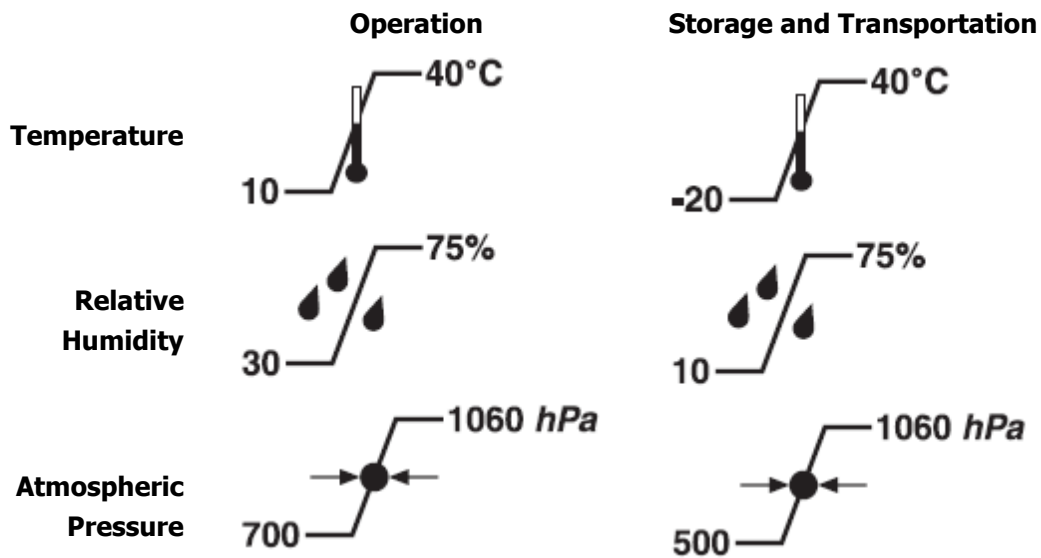

Figure 10 – Environmental Conditions

# Maintenance

## Qualifications for Service Personnel

Service personnel will be trained during the installation of the equipment on preventative maintenance, troubleshooting and common problems. Support for the service technicians is always available by calling Customer Service at 1-888-466-6633.

Qualifications needed to properly service products manufactured by DMS in no way allows for or authorizes any person to avoid the authorities with jurisdiction to impose additional requirements for qualifications on service personnel.

DMS recommends that all facilities service and healthcare professionals attend the Maintenance & In-Service Training sessions offered during the time of equipment installation.

All maintenance to be performed by qualified personnel only. Repairs by unauthorized individuals should not be attempted and may result in damage to or malfunction of the system or even personal injury.

## Service Warnings



### **WARNINGS:**

- Modification of this equipment is not allowed.
- When performing any service or maintenance procedures on the cart, follow all manufacturers' instructions.
- Handling biohazard waste is potentially dangerous. Wear personal protective equipment when servicing the cart.
- Prior to performing any maintenance on the evac, unplug the unit from the wall outlet. Not unplugging this unit will leave dangerous voltages & current accessible to the service personnel working on or in this machine.

**NOTE:** If the unit is to be moved, wipe down the outside of the unit with a hospital approved bleach wipe. (Sani-Cloth Bleach Germicidal Wipe (DMS# UL-BW100), Clorox: Germicidal Wipes or equivalent)

**NOTE:** Remove all fluids from the bottom of the unit's lower cabinet before returning equipment to service.

## Additional Information

Upon request DMS will provide the following: Circuit Diagrams, Component Parts List, Description of Components, Calibration Instructions, and any parts information needed for repair of the unit.

# Routine Maintenance

## Front Panel Removal

Call DMS at 1-888-466-6633 prior to removing or servicing any components that require the front panel to be removed. Removal of the front panel will allow access to the electrical components underneath. Once removed the possibility of electrical shock is present. Use caution when performing any service to these components. To take off the front panel, remove the two screws on either side of the green top and raise the top. Remove the two screws on either side of the front panel near the bottom of the unit at the back edges of the panel. Lift the panel up and out to remove. Note: This panel has a ground wire attached to it.

## Inspections

Regularly visually inspect the unit for any signs of damaged or leaking components. If any problems are found, contact Customer Service at 1-888-466-6633 to report findings.

# Replacement Items

## Power Supply

There is not a substitute power supply replacement. The power supply must be replaced with the following:

- Manufacturer: Condor
- Model #: GLM75 Medical

Contact DMS for replacement parts at 1-888-466-6633.

## Replacement Fuses

Two sets of replacement fuses are located on the main circuit board. Fuse specifications are as follows:

- Fuse replacement for the main ICB power – 250V 5A time delayed fuse.
- Fuse replacement for the drain pump – 250V 8A time delayed fuse.

## Power Cord Replacement

Contact DMS for replacement only (see components part list), Procedure for replacement (correct connection & anchoring) are provided with the replacement power cord.

# Fluid Paths and Wiring Diagrams

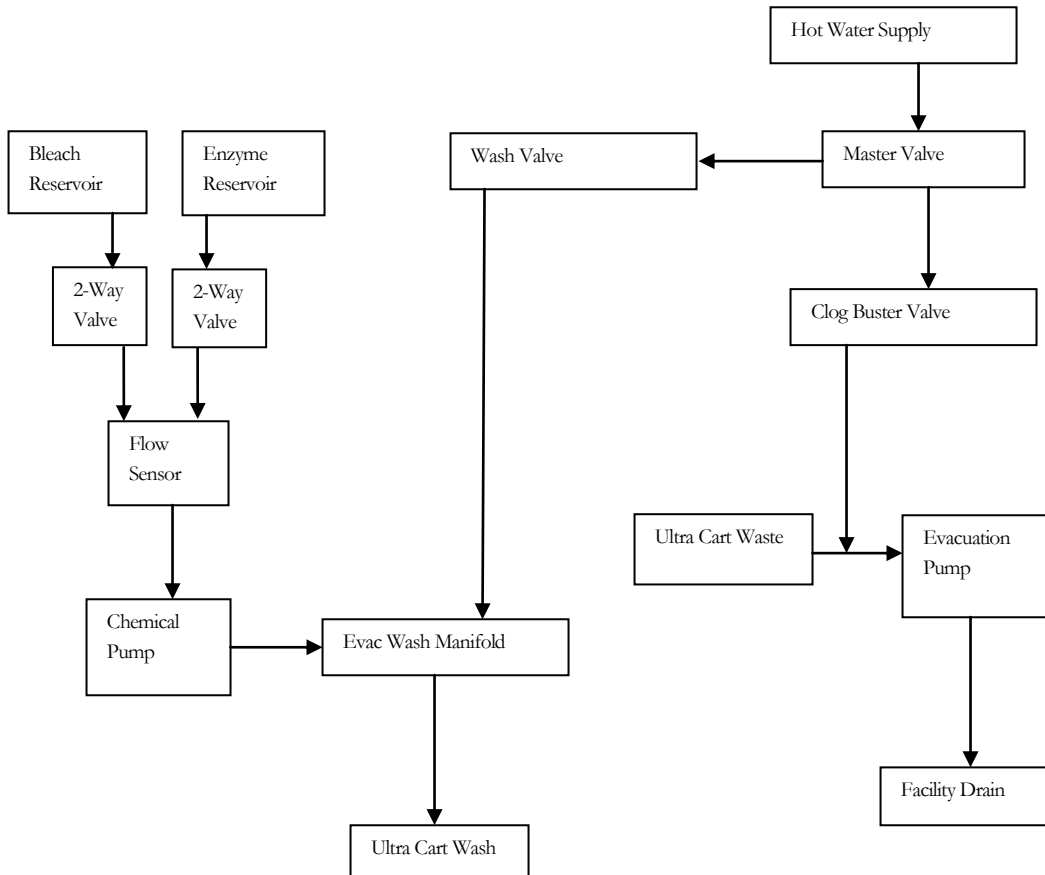

**Figure 11** – Ultra Evac Unit Fluid Flow Diagram

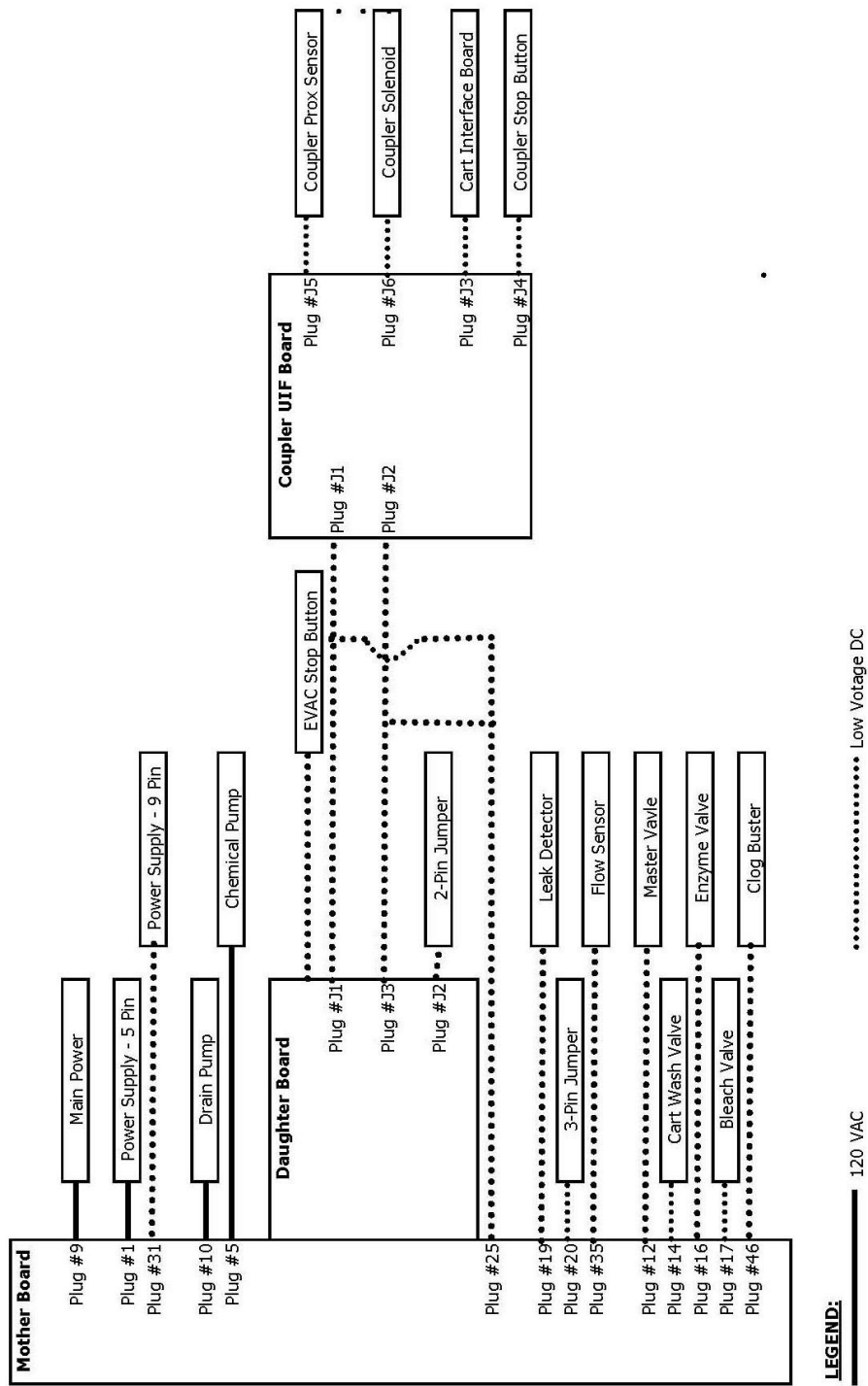

Figure 12 – Ultra Evac Unit Wiring Diagram





# Preventative Maintenance

The Ultra Evac Unit preventative maintenance schedule is presented below. Preventive maintenance parts kits can be ordered directly from DMS by calling 1-888-466-6633.

**Table 3 – Preventative Maintenance Schedule**

Procedure	Year End				Required Parts	
	1	2	3	4	Part #	Quantity
Annual PM Kit	X	X	X	X	PM-007	1
Replace Solenoid Valve		X		X	12520	3

Note: Preventative Maintenance Procedures are available upon request by contacting Customer Service at 1-888-466-6633.

# Company Information

DMS has been helping healthcare facilities responsibly manage infectious fluid waste since 1997. Starting out as the premier manufacturer for fluid waste management systems in the country, we now have installations in leading healthcare facilities nation-wide.

DMS was founded in 1995. Products are manufactured and shipped from a centralized facility and supported by a nation-wide sales force. The company's principals include individuals with extensive backgrounds in product development, management, production, and sales of medical/surgical products. Jim Dunn, a successful inventor who served as an operating room nurse for 20 years, helped design DMS products.

## Contact Information

Dornoch Medical Systems, Inc.

Shipping Address:

200 NW Parkway  
Riverside, MO 64150

Office Correspondence:

P.O. Box 681656  
Riverside, MO 64168

Toll free: 1-888-466-6633

Phone: 1-816-505-2226

Fax: 1-816-505-1050

Web: [www.dornoch.com](http://www.dornoch.com)

# Limited Warranty

Dornoch Medical Systems, Inc. (hereinafter 'DMS') warrants each new Transposal Product (as listed in the Transposal Product Guide, published by DMS from time to time) which is identified as "capital equipment" on the Purchase Agreement or Trial Agreement entered into in connection herewith, to be free from defects in materials and workmanship under normal use and service for a period of one (1) year from the date of installation (the "Term"). Both parts and labor are covered for the one-year period per the conditions below.

Notwithstanding the foregoing, if any Transposal Product requiring installation is not installed by a DMS Customer Service Engineer, the term of this limited warranty shall begin 14 days (two weeks) after the date the Transposal Product has been shipped by DMS. And for any Transposal Product which does not such installation, the Term of this limited warranty shall begin three (3) days after the date the Transposal Product has been shipped by DMS. Any replacement part, including a user-installed part that has been installed in accordance with instructions provided by DMS, is subject to this limited warranty for the period remaining in the Term for the subject Transposal Product.

NOTWITHSTANDING ANYTHING TO THE CONTRARY, DMS DOES NOT WARRANT ANY OF THE FOLLOWING THAT MAY BE SHIPPED WITH OR AN INTEGRAL PART OF ANY TRANSPOSAL PRODUCT OR SUPPLIES REQUIRED TO OPERATE OR INSTALL ANY TRANSPOSAL PRODUCT: (I) ITEMS AND PRODUCTS NOT MANUFACTURED BY DMS, INCLUDING, BUT NOT LIMITED TO ENZYMATIC CLEANER, TUBING, AND ANY BACKFLOW PREVENTER; (II) ITEMS AND PRODUCTS DESIGNED FOR SINGLE USE, INCLUDING BUT NOT LIMITED TO, CANISTER LIDS AND CART LIDS; AND (III) ITEMS AND PRODUCTS IDENTIFIED AS "CONSUMABLE/CONVERSION SUPPLIES" ON A PURCHASE AGREEMENT OR TRIAL AGREEMENT ENTERED INTO IN CONNECTION HEREWITH.

DMS' liability shall be limited, at its sole option and expense, to repair or replace during DMS' normal service hours any Transposal Product which has been examined by DMS and found, in the sole discretion of DMS, to be defective. The maximum liability of DMS to any person whatsoever arising out of or in connection with the sale or use of its equipment, whether such liability arises from a claim based upon contract, warranty, tort, or otherwise, shall in no case exceed the actual value of the equipment paid by the purchaser. DMS shall not be liable to the purchaser or to any other person or entity for incidental or consequential damages.

DMS reserves the right to replace defective parts or equipment with parts which may not be identical to the original equipment or parts. Said replacement parts or equipment shall be, in the judgment of DMS, equal to or better in performance than parts or equipment initially furnished.

THIS EXPRESS LIMITED WARRANTY IS IN LIEU OF ALL OTHER WARRANTIES, EXPRESS OR IMPLIED, INCLUDING THE IMPLIED WARRANTIES OF FITNESS FOR A PARTICULAR PURPOSE AND MERCHANTABILITY.

DMS reserves the right to discontinue any Transposal Product, incorporate new features, specifications, colors, etc., at any time without incurring obligations to provide similar equipment or features on previously sold models of equipment or parts.

This warranty applies to the original purchaser only and is not transferable, except to the end user in a lease financed transaction, and then, if and only if, and to the extent specifically approved by DMS in writing.

This limited warranty shall be construed and interpreted in accordance with and governed by the internal laws of the State of Missouri (without giving effect to Missouri choice or conflict of law principles).

PURCHASER IRREVOCABLY AGREES THAT, SUBJECT TO DMS' SOLE AND ABSOLUTE DISCRETION, ALL ACTIONS OR PROCEEDINGS IN ANY WAY ARISING OUT OF OR RELATED TO THIS LIMITED WARRANTY WILL BE LITIGATED IN COURTS HAVING SITUS IN KANSAS CITY, MISSOURI. PURCHASER HEREBY CONSENTS AND SUBMITS TO THE JURISDICTION OF ANY COURT LOCATED WITHIN MISSOURI.

THIS WARRANTY SHALL BE VOIDED IF (I) ANY PARTY OTHER THAN A DMS CUSTOMER SERVICE ENGINEER REPAIRS OR REPLACES OR ATTEMPTS TO REPAIR OR REPLACE ANY TRANSPOSAL PRODUCT OR PARTS AND DOES NOT FOLLOW SPECIFIC INSTRUCTIONS PROVIDED BY DMS FOR SUCH REPAIR OR REPLACEMENT OF PARTS OR (II) ANY TRANSPOSAL PRODUCT (A) IS NOT USED IN ACCORDANCE WITH INSTRUCTIONS PROVIDED BY DMS (including water hook-ups at hardness levels above five (5) grains per gallon), (B) IS NOT ACCORDED REASONABLE TREATMENT BY THE PURCHASER OR (C) IS USED IN A MANNER INCONSISTENT WITH THE FOLLOWING: TRANSPOSAL ULTRA EQUIPMENT MUST NOT BE USED TO DISPOSE OF ANY SOLID MATERIAL, INCLUDING BUT NOT LIMITED TO NEEDLES, SYRINGES, HARDENED CASTING MATERIAL, TISSUE OR ANY OTHER SOLID OR SEMI-SOLID. SHOULD ANY TRANSPOSAL PRODUCT BE USED IN A MANNER INCONSISTENT WITH THE FOREGOING AND A DRAIN BLOCKAGE OCCURS, THE PURCHASER SHALL BE SOLELY RESPONSIBLE FOR THE COST OF ALL REPAIRS OF THE TRANSPOSAL EQUIPMENT AND OF ANY FACILITY DRAINAGE SYSTEMS AND ANY OTHER RELATED DAMAGE.