

---

# VITALOGRAPH-*alpha* SERVICE MANUAL

---

Buckingham  
Hamburg  
Kansas City  
Ennis

## CONTENTS

	PAGE
1. REPAIRS AND SERVICE	2
2. TECHNICAL INTRODUCTION	2
3. ACCURACY CHECK/CALIBRATION	3
4. SPARE PARTS LIST	5
5. SPARE PARTS FITTING INSTRUCTIONS	9
6. FAULT FINDING GUIDE	13
7. CONSUMABLES AND ACCESSORIES	16
8. CLEANING/DISINFECTING/STERILISING	16
9. TECHNICAL DATA LIST	18
10. GUARANTEE AND CUSTOMER SERVICE	21

Current Edition (Issue 2)

Copyright © 1987 and 1988 by Vitalograph Ltd., Buckingham, England.

Vitalograph Ltd., Maids Moreton House, Buckingham, MK18 1SW.

☎ (0280) 816868 · Telex: 83480 (VITALB G) · Fax: (0280) 815609

Vitalograph GmbH, Jacobsenweg 12, 2000 Hamburg 54.

☎ (040) 540 30 26/27 · Telex: 212466 (VITAL D) · Fax: (040) 540 65 32

Vitalograph Inc., 8347 Quivira Road, Lenexa, Kansas 66215.

☎ (913) 888-4221 · Toll Free 1-800-255-6626 · Fax: (913) 888-4259

Vitalograph (Ire.) Ltd., Ennis Ind. Estate, Gort Road, Ennis, Co. Clare.

☎ (065) 29611 · Telex: 26832 (VITA EI) · Fax: (065) 29289

## 1. REPAIRS AND SERVICE

Servicing of the Vitalograph-**alpha** should be carried out only by qualified service technicians. There are no user-serviceable components inside the equipment.

For any technical assistance or for the names and addresses of approved Vitalograph Service Agents, please contact any of the following offices:

Vitalograph Ltd., Maids Moreton House, Buckingham, MK18 1SW.

☎ (0280) 816868 · Telex: 83480 (VITALB G) · Fax: (0280) 815609

Vitalograph GmbH, Jacobsenweg 12, 2000 Hamburg 54.

☎ (040) 540 30 26/27 · Telex: 212466 (VITAL D) · Fax: (040) 540 65 32

Vitalograph Inc., 8347 Quivira Road, Lenexa, Kansas 66215.

☎ (913) 888-4221 · Toll Free 1-800-255-6626 · Fax: (913) 888-4259

Vitalograph (Ire.) Ltd., Ennis Ind. Estate, Gort Road, Ennis, Co. Clare.

☎ (065) 29611 · Telex: 26832 (VITA EI) · Fax: (065) 29289

## 2. TECHNICAL INTRODUCTION

The Vitalograph-**alpha** detects the flow of expired air using a Lilly Pneumotachograph type flowhead connected to one side of a differential pressure transducer. The back pressure created by the resistance of the mesh is transferred to the pressure transducer via the Pitot Tube and a flexible pipe.

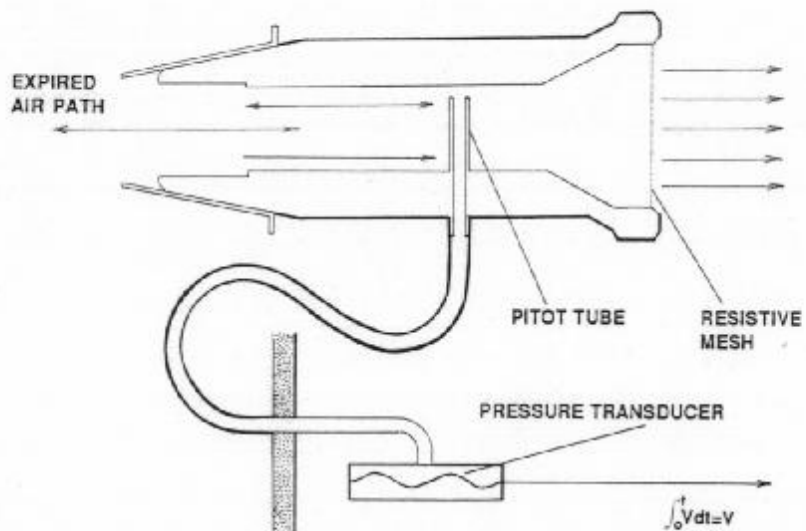

FIG. 1.

The output voltage from the pressure transducer is proportional to the flow through the flowhead. During testing, the flow signals are integrated to obtain measured volumes; these are displayed on the screen at the end of each test, alongside predicted values. The test results may be printed out subsequently, if required.

This routine allows the user to simply check, and adjust if necessary, the calibration of the instrument. **The actual adjustment, if made, is carried out totally by control from the keyboard and no actual mechanical adjustment is necessary.** The revised calibration is retained until altered again, even when the machine is switched off.

### 3. ACCURACY CHECK/ CALIBRATION

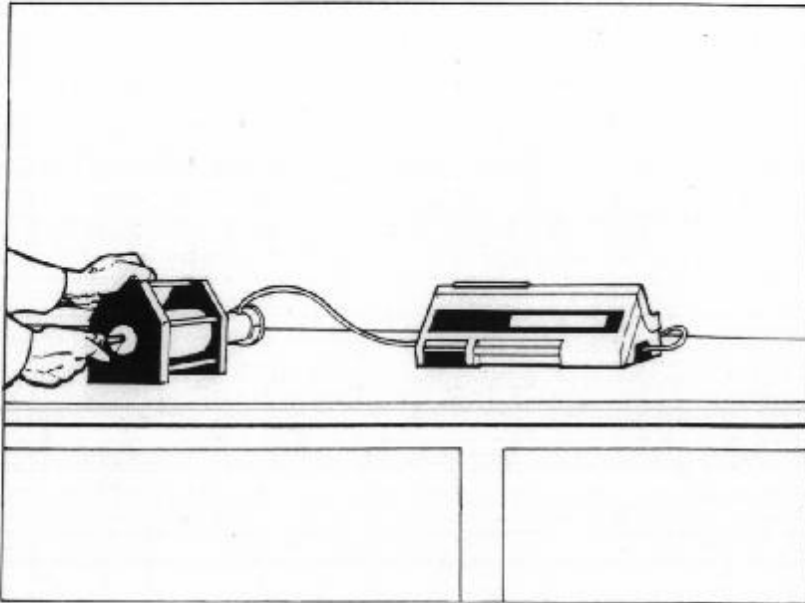

FIG. 2.

To perform the accuracy check/calibration a precision syringe is required. Before attempting calibration it is essential that the flowhead and syringe are at ambient room temperature. Blowing through the flowhead raises its temperature. If the flowhead has recently been blown through by a patient prior to calibration, then the temperature must be lowered to ambient by pumping room air through it prior to accuracy check using the syringe.

### Recommended Calibration Procedure

1. It is important to pump 10 litres (approx) of air through the flowhead prior to commencing this procedure.
2. The user is asked to enter the ambient temperature. **THIS MUST BE MEASURED ACCURATELY BEFORE ENTERING.**
3. Air must be pumped through the flowhead when requested on the screen. The air must be pumped through the flowhead for at least one second continuously or it will be ignored.
4. At the end of the first stroke of the syringe, the user may exit the routine or pump more air to increase the calibration volume.
5. If a second stroke of the syringe is to be performed it is important to wait for at least half a second after the syringe fills. This allows the system to settle.
6. Strokes of the syringe may be repeated up to a maximum displayed volume of 9.99L.
7. When the air pumping routine is exited the measured volume is displayed and the user is requested to enter the actual total volume pumped. This is then compared with the measured value and a difference indication is displayed.
8. The user is then offered the chance to change the calibration. This is only necessary **IF THE ERROR IS GREATER THAN 3%.**
9. Once the check or adjustment is completed a Calibration Report is printed.

4.  
SPARE PARTS  
LIST

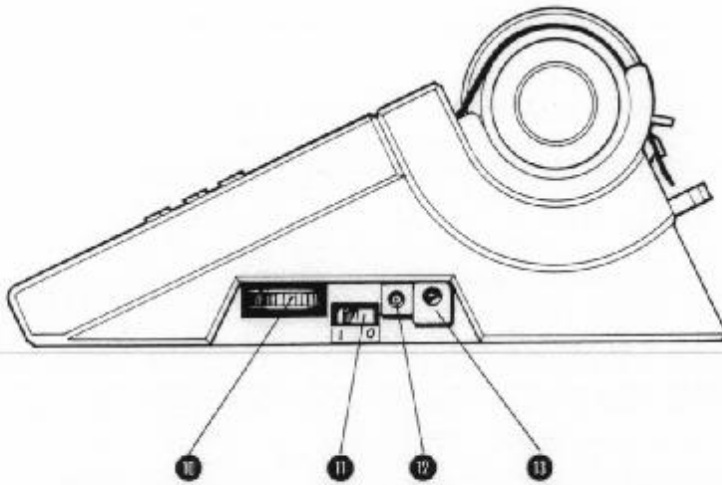
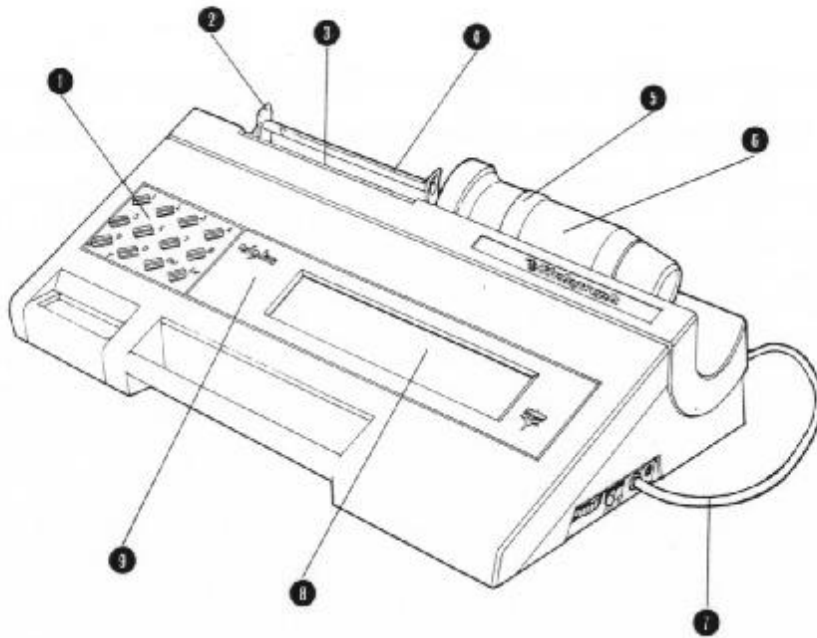

- |                                  |  |
|----------------------------------|--|
| 1. Keypad Complete - 44.002SPR   | 8. LCD Display Glass - 44.011SPR           |
| 2. Paper Roll Clip - 44.016SPR   | 9. LCD Surround - 44.004SPR                |
| 3. Paper Tear Bar - 44.017SPR    | 10. Contrast Control with Knob - 31.583SPR |
| 4. Paper Roller - 44.015SPR      | 11. On/Off Switch - 31.639SPR              |
| 5. Rubber Strap - 44.014SPR      | 12. Pressure Inlet Port - 44.070SPR        |
| 6. Flowhead Complete - 44.026SPR | 13. Power Inlet Socket - 31.625SPR         |
| 7. Pressure Tube - 44.028SPR     |  |

FIG. 3. IDENTIFICATION - EXTERNAL PARTS

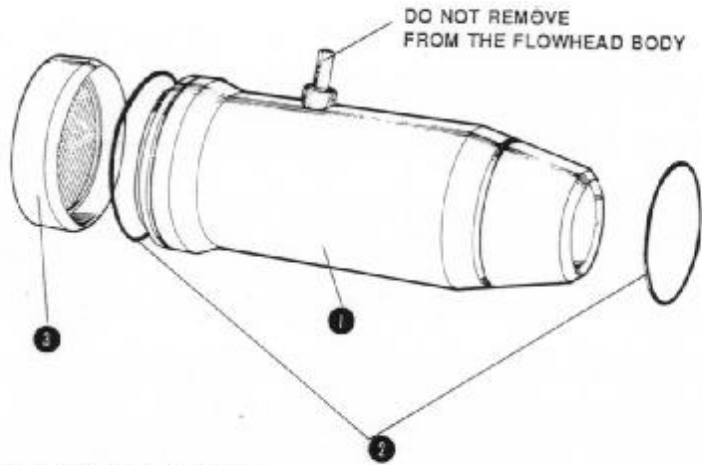

1. Flowhead Complete - 44.026SPR
2. Flowhead Seal Kit - 44.029SPR
3. Semi Disposable Resistive Element (Refer to Consumables List)

FIG. 4. FLOWHEAD PARTS IDENTIFICATION

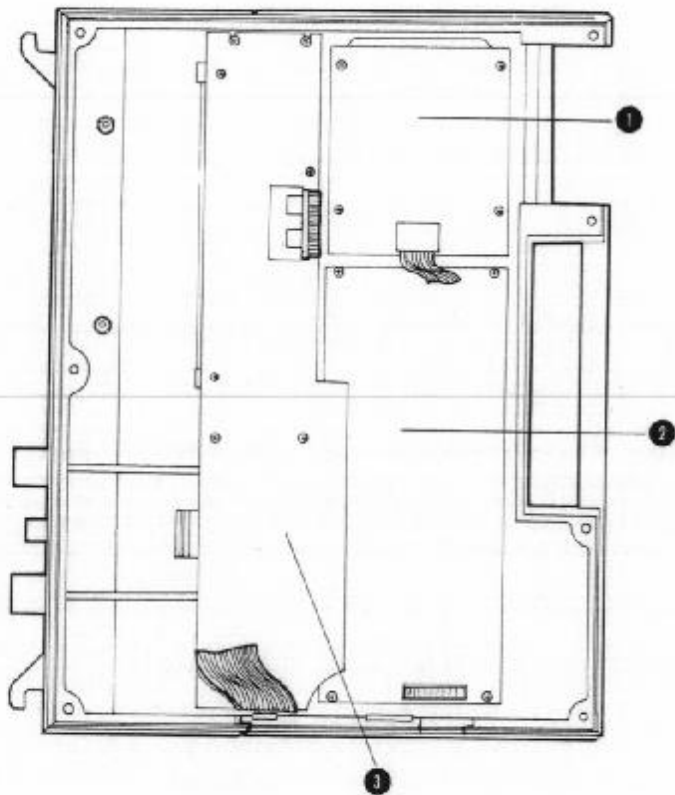

1. Keypad Complete - 44.002SPR
2. LCD Display with Lead - 44.039SPR
3. Printer with Board - 31.581SPR

FIG. 5. INTERNAL VIEW - TOP HALF PARTS IDENTIFICATION

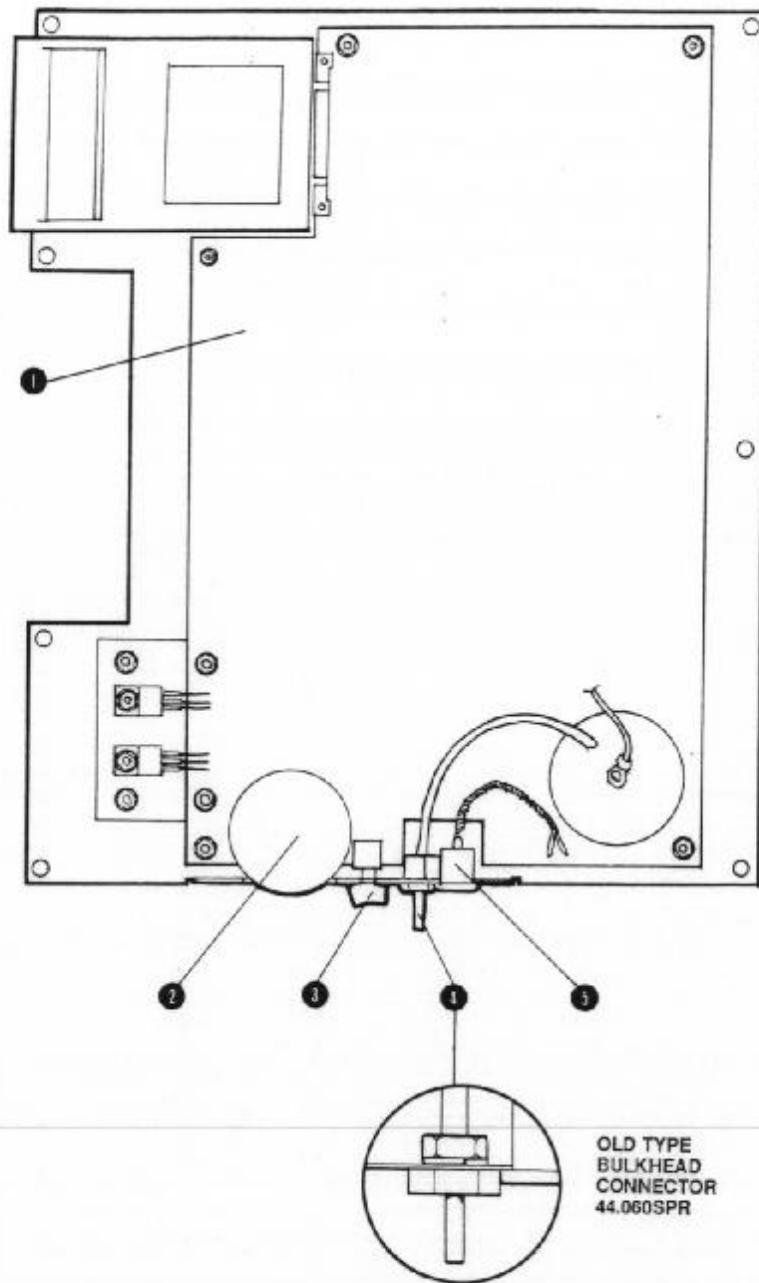

OLD TYPE  
BULKHEAD  
CONNECTOR  
44.060SPR

- 1. Main PCB Service Exchange - 44.031SPR
- 2. Contrast Control with Knob - 31.583SPR
- 3. On/Off Switch - 31.639SPR
- 4. Pressure Inlet Port - 44.070SPR
- 5. Power Inlet Socket - 31.625SPR

FIG. 5. INTERNAL VIEW - BOTTOM HALF PARTS IDENTIFICATION



**SPARE PARTS LIST**

<b>DESCRIPTION</b>	<b>ORDER CODE</b>	<b>FITTING NOTE LOCATION</b>
<b>Hardware</b>		
Printer with Board	31.581SPR	Refer to Section 6
Contrast Control with Knob	31.583SPR	Refer to Section 6
Power Inlet Socket	31.625SPR	Refer to Section 6
On/Off Switch	31.639SPR	Refer to Section 6
Keypad Complete	44.002SPR	Refer to Section 6
LCD Surround	44.004SPR	Refer to Section 6
LCD Display Glass	44.011SPR	Refer to Section 6
Rubber Strap	44.014SPR	Refer to Section 6
Paper Roller	44.015SPR	N/A
Paper Roll Clip	44.016SPR	Refer to Section 6
Paper Tear Bar	44.017SPR	Refer to Section 6
Flowhead Complete	44.026SPR	Refer to Section 8
Pressure Tube	44.028SPR	N/A
Flowhead Seal Kit	44.029SPR	Refer to Section 8
Main PCB Service Exchange	44.031SPR	Refer to Section 6
LCD Display with Lead	44.039SPR	Refer to Section 6
Vitalograph-alpha Carrying Case	44.048SPR	N/A
LCD Connecting Lead	44.051SPR	N/A
Dust Cover	44.054SPR	N/A
Pressure Inlet Port	44.070SPR	Refer to Section 6
Bulkhead Connector (early)	44.060SPR	Refer to Section 6
<b>PowerSAFE</b> Adaptor (Europe/Germany)	44.036SPR	N/A
<b>PowerSAFE</b> Adaptor (U.K. 13 amp plug)	44.043SPR	N/A

THE FITTING OF ANY SPARE PARTS SHOULD BE CARRIED OUT BY QUALIFIED SERVICE TECHNICIANS ONLY.

## 5. SPARE PARTS FITTING INSTRUCTIONS

### INSTRUMENT ACCESS

Switch **MAINS POWER OFF** and disconnect power supply lead from side of instrument. Remove flowhead connection tubing from the connector on base. Turn unit over and place on foam mat or other soft surface to avoid damage to facia.

Slacken and remove the seven screws indicated on the illustration using a No. 2 posidriv screwdriver.

**NOTE: DO NOT ATTEMPT TO REMOVE BASE AT THIS STAGE**

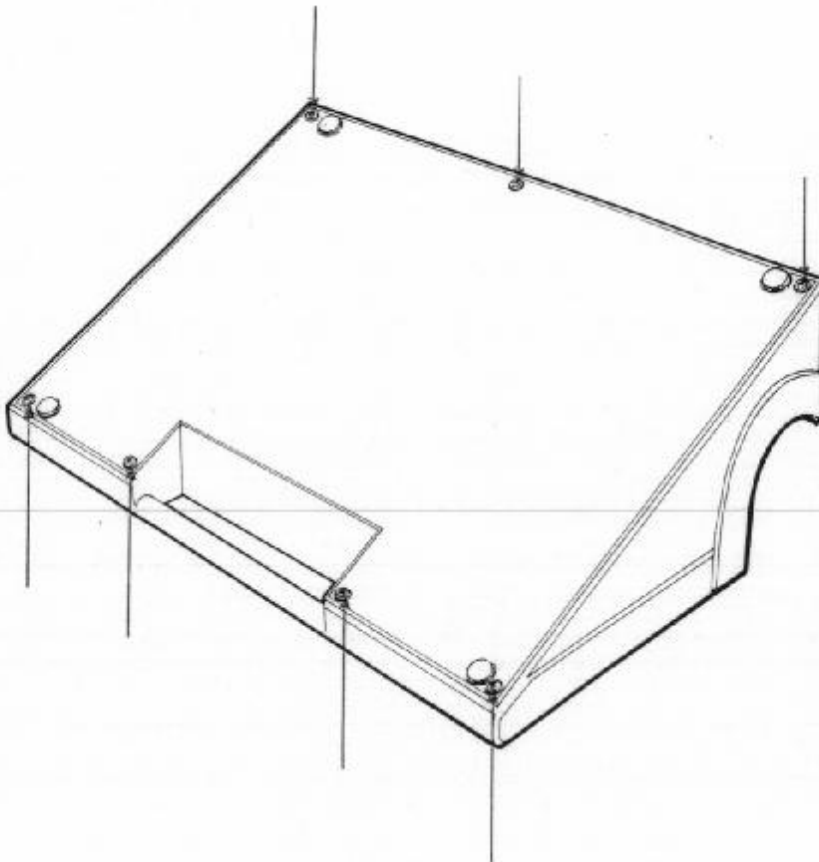

FIG. 7. UNDERSIDE VIEW INDICATING SCREWS TO BE REMOVED FOR INTERNAL INSTRUMENT ACCESS

After the screws have been removed, turn the instrument over onto its feet. Very carefully lift away the case only far enough to allow disconnection of all the inter-connecting leads as shown on the following page.

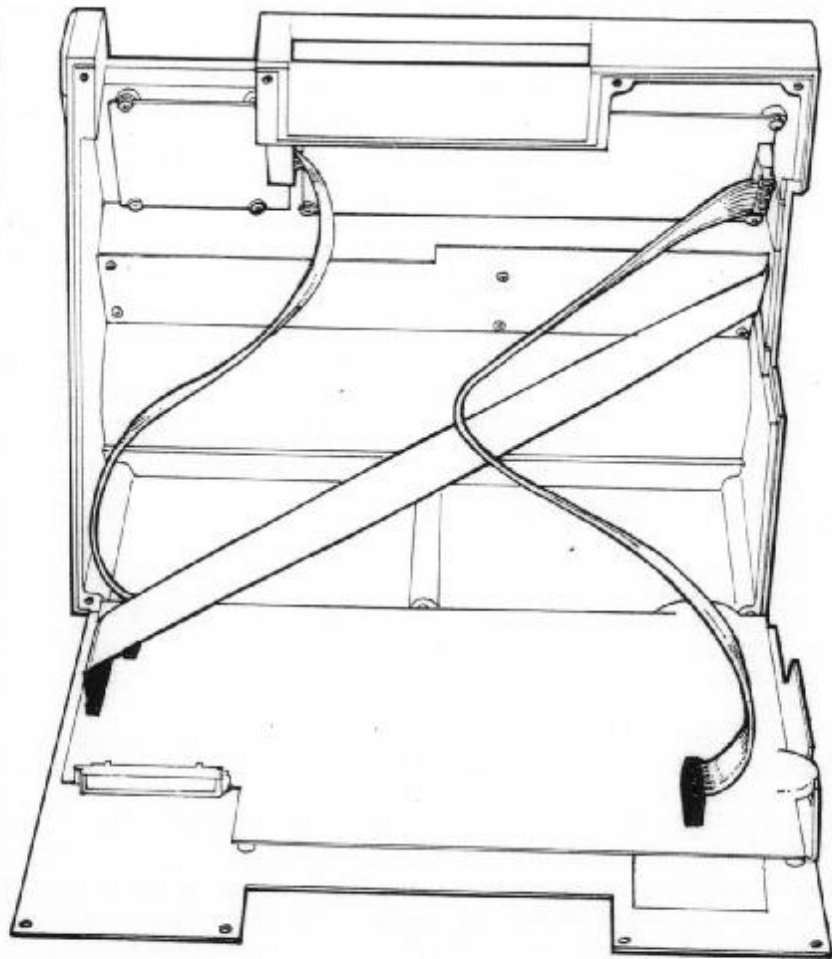

FIG. 8. CASE BEING REMOVED FOR INSTRUMENT ACCESS

**NOTE:**

To separate top and bottom halves, the connectors shown in RED must be disconnected. Ensure correct orientation on re-assembly.

**Printer with Board - 31.581SPR**

Refer to figures 7 and 8 for internal instrument access. The printer board is retained in the case by five screws; removal of the complete assembly is simply achieved by removing these and replacing the unit. Do not attempt to fit a new printer to the existing printer board, always use the replacement assembly.

#### **Contrast Control with Knob - 31.583SPR**

Refer to figures 7 and 8 for internal instrument access. Removal of the main PCB from the base is required when replacing this component (refer to Main PCB Service Exchange - 44.032SPR fitting instructions). The contrast control is soldered to the board. It is therefore necessary to unsolder this and re-solder the replacement part into position. Ensure that the replacement is pushed down squarely onto the board before resoldering, to maintain correct alignment.

#### **Power Inlet Socket - 31.625SPR**

Refer to figures 7 and 8 for internal instrument access. The power inlet socket is a slide fit into the base panel and is connected to the main PCB via discrete wires; these should be unsoldered at the socket and the replacement fitted in its place.

#### **On/Off Switch - 31.639SPR**

Refer to figures 7 and 8 for internal instrument access. Removal of the main PCB from the base is required when replacing this component (refer to Main PCB Service Exchange - 44.031SPR fitting instructions). The on/off switch must be unsoldered from the board and the replacement soldered back into position.

#### **Bulkhead Connector - 44.060SPR**

Refer to figures 8 and 9 for internal instrument access. The pressure tapping is held in place by an M4 nut. Remove the flexible pipe from the pressure tapping and unscrew the retaining nut. The refitting procedure is a reversal of the removal procedure.

#### **Keypad Complete - 44.002SPR**

Refer to figures 7 and 8 for internal instrument access. Lay the case face down on a soft surface and remove the four screws retaining the keypad PCB. Lift away the PCB which will expose the rubber membrane, remove the complete keypad at this stage and discard. Fit the new keypad moulding to the case and drop the keys into their apertures. The new rubber membrane locates in the rear face of the keypad moulding and is trapped by fitting the new PCB. Ensure free operation of Keys before finally tightening fixing screws.

#### **LCD Surround - 44.004SPR**

The LCD surround is fitted to the case using double-sided adhesive tape. To remove it simply lever it out of its location, remove any residual tape from the case, and fit the replacement using the tape provided.

#### **LCD Display Glass - 44.011SPR**

Refer to figures 7 and 8 for internal instrument access. Remove four screws retaining LCD display and remove display. The display glass is held in position by double-sided adhesive tape. To remove push carefully on the front face and lift clear. The new part is fitted, ensuring that no residual tape is left in the recess of the case. Use the new tape provided when fitting the replacement.

#### **Rubber Strap - 44.014SPR**

To fit a replacement strap remove the damaged part and feed the open end of the new part into the retaining slot; use a small screwdriver if necessary to push it home.

#### **Paper Roll Clip - 44.016SPR**

Refer to figures 7 and 8 for internal instrument access. The paper roll clip is retained by two nuts; found on the inside of the case; remove the nuts and fit the replacement part in reverse order of the removal procedure.

#### **Paper Tear Bar - 44.017SPR**

Refer to figures 7 and 8 for internal instrument access. Remove the printer board assembly (refer to printer with board - 31.581SPR fitting instructions). The tear bar is retained by two spring clips, which must be prised carefully from their locating pins. Replacement is a reversal of the removal procedure.

#### **Main PCB Service Exchange - 44.031SPR**

Refer to figures 7 and 8 for internal instrument access. Remove plastic tube from pressure tapping and slide power inlet socket out of its retaining slot in the base. Remove two outer nuts from heat sink plate and five plastic nuts from edges of PCB. **DO NOT REMOVE THE INNER TWO NUTS ON THE HEATSINK PLATE OR THE TWO NUTS WHICH HOLD THE HEATSINK AND THE PCB TOGETHER.** Lift the PCB from the base studs and remove complete assembly.

Clean heat sink compound from base around the heat sink mounting position. Apply heat sink compound provided to underside of heat sink on new PCB and spread evenly. Ensure that plastic spacers are fitted to the five studs which support the PCB and fit new PCB into position. Replace all nuts and tighten. Do not overtighten plastic nuts. Wipe away excess heat sink compound from edges of heat sink plate and refit power inlet socket and plastic tube to pressure tapping. Reassemble base and case halves, ensuring connection of interconnecting leads.



# CHEMTRONICS

Biomedical Engineering

ABN : 33 370 664 005

40 MERCY ST.  
BENDIGO VIC 3550

Bendigo Workshop

Telephone : 03 5441 6753  
Facsimile : 03 5444 0507

Service Report PM392386

### CUSTOMER DETAILS

SWAN HILL DISTRICT HOSPITAL  
P.O. BOX 483  
SWAN HILL  
3585

### EQUIPMENT DETAILS

BMI Number	053349
Customer Barcode	EM0594
Asset Description	INFUSION PUMP, GENERAL PU
Make	SIMS GRASEBY
Model	500
Serial No	30060593
Department	WARD 1
Last Update	20-Nov-2007 15:17
Engineer	Iblandhorn
Order No.	14397
TFMS No.	

Campus  
D422/SWAN HILL  
Contact Name  
WILLIAMSON, ANDY  
Requested by  
Phone Number  
03 5033 9300

### Fault Description

DISPLAYS , SYSTEM CHECK & OCCLUSION BELOW PUMP  
INSPECT UNIT FOR DAMAGE OR FAULTS - NONE FOUND.  
SETUP & PERFORM BASIC TEST - OK.  
UNIT PLACED ON EXTENDED BENCH TEST.  
NO FAULT OCCURRED DURING TEST PERIOD.  
CHECKED OVERALL PERFORMANCE - OK.  
SAFETY AND PERFORM ACE TESTED TO AS:3551(2004)

### Loan Equipment

Expense Type	Description	Quantity
freight	FREIGHT (INC. P&H) - DELIVERY TO CUSTOMI Con# 110526 0000265	1

### LCD Display with Lead - 44.039SPR

Refer to figures 7 and 8 for internal instrument access. Remove four screws retaining the display in the rear face of the case and lift clear. Cut to length, and stick on foam tape provided around complete perimeter of the metal housing of the new display. The foam tape has a liner on the rear face which when removed will expose a self adhesive tape surface. Refer to the removed screen for correct positioning of the foam tape. Dust ingress between the display and display glass is prevented by the foam. Reassembly is a reversal of the removal procedures.

#### PROBLEM

#### SOLUTION

No instrument response when turned on.

Check fuses in the mains plug (where applicable) and proper insertion of the power supply lead. Check power at wall socket. Check that the software cartridge is fully inserted.

The instrument operates intermittently and "jumps" to the start of the programme.

Check the following: The mains plug is properly inserted into the wall socket. The power inlet plug is fully inserted into the socket in the side of the machine.

Test begins automatically and volume accumulates for 20 seconds without the patient blowing or very small VC or FVC test displayed or only responds to very large air flows.

Keep flowhead and tubing stationary at the start of a test until the 'READY' prompt appears. Return to MENU and re-enter the test routine.

Calibration air not accepted or measured volumes vary greatly from the volumes of pumped air.

Keep flowhead, tubing and syringe plunger stationary until prompted to 'PUMP AIR'. Terminate the calibration procedure WITHOUT UPDATE, return to menu and re-enter the calibration procedure.

Last entered DATE corrupted on 'Power On' and/or obviously false test readings.

Internal eprom corrupted. Re-enter the correct date and re-calibrate the instrument.

## 6. FAULT FINDING GUIDE

**PROBLEM****SOLUTION**

Printer operating but no print-out appearing on paper.

Check that paper roll is inserted correct side up.

Erratic recording of test.

Check that the tubing from the flowhead has not become deformed by being trapped under the instrument and that there are no tight bends and kinks along its length.

Test results appear to be suspiciously high.

Check that the flowhead resistive element has not become soiled. If necessary clean and dry or replace the element and recalibrate.

**Internal Testing**

Refer to section 5 (Instrument Access) and remove the chassis from the instrument case. Place the case on the left of the chassis and leave all the interconnecting cables connected.

Carefully examine all the interconnecting cables and make sure that they are fully inserted into the various sockets.

**PowerSAFE Supply Voltage**

Using a voltmeter, with the negative input on zero (TP12), measure the voltage at the input connection to the PCB. This is marked on the PCB as VP +. The voltage here should be approximately 9.5 volts. If this voltage is not present check for faulty connections at the power input socket.

**On/Off Switch**

If the PowerSAFE supply voltage is correct then proceed to check the on/off switch. Place switch in OFF position and with the voltmeter on zero volts (TP12) check that supply voltage is present at pin 1 of the switch. Operate the switch and the supply voltage should appear at pin 2 of the switch. If the supply voltage is not present then a faulty switch is indicated.

**Internal Power Supplies**

Check that the power supply voltages generated on the PCB are correct. These are measured between the zero volt test point (TP12) and positions on the board marked with the relevant voltages.



Voltages marked on PCB	Correct Voltage
TP12 and + 5V	4.9/5.1
TP and + 10V	+9.6/+10.4
TP and -10V	-9.6/-10.4
TP and -12V	-12/-12.4

The supply for the printer head drive 5.75/6.3V can be measured between TP12 and TP13.

#### Liquid Crystal Display

The -12 Volt supply above is used to drive the LCD (Liquid Crystal Display) screen. If this voltage is not correct then the display will appear blank. If the supply is correct but the screen is blank or it has become impossible to change the "viewing angle" of the display then the contrast potentiometer should be checked.

#### Contrast Potentiometer

This device is designated RV2 on the PCB. To check that it is working correctly, switch off the instrument and disconnect the power connector from the PowerSAFE and remove the display ribbon connector from PL4. With an ohm meter measure the resistance of the potentiometer between its centre connection and the -12 volt position marked on the PCB. Rotate the control knob and the reading on the ohm meter should vary from approximately zero ohms to 22 kilohms. If the reading is a fixed value of 22 kilohms wherever the control is set or the reading is erratic then the potentiometer should be replaced.

N.B. Reconnect the display ribbon connector after completing this test.

#### Printer

If the printer motor runs when the machine is required to print out test information but the paper remains blank then check the 6 volt printer head supply as mentioned in the paragraph "Internal Power Supplies". If the quality of the print-out has become poor i.e. alpha numeric characters are not totally bold and the vertical graph axis have become "broken" lines then the printer head may have become faulty and the printer PCB will require replacement.

N.B. Never perform a print-out without paper in the printer mechanism or permanent damage will result immediately.

### Erratic Test Results

If the spirometer is producing erroneous test results this may be caused by the trimming capacitors breaking free from their solder posts. Check that the two capacitors mounted on solder pins, CT1 and CT2, near the transducer body, are properly connected.

Also check that the screws holding the pressure transducer to the PCB have not become loose.

## 7. CONSUMABLES AND ACCESSORIES

20.302	Paediatric Mouthpiece Adaptor
20.202	Paediatric Mouthpieces (box of 400)
20.201	Cardboard Mouthpieces (box of 200)
42.085	COMPACT Mouthpieces (pack of 200)
20.303	Nose Clips (pack of 10)
20.408	1-litre Precision Syringe
44.057	Resistive Elements (pack of 5)
44.058	Thermal Printer Paper (5 rolls)

### SOFTWARE CARTRIDGES

44.125	Standard Program
44.128	Flow Volume Program
44.130	Pre/Post Program

## 8. CLEANING/ DISINFECTING/ STERILISING

### Cleaning/Disinfecting/Sterilising - Recommendations Chart

PART	MATERIAL	CLEANING	DISINFECTING	STERILISING
Case	Polystyrene	Lint free	Mild liquid	N/A
Exterior	high density foam painted with epoxy paint	damp cloth <b>DO NOT USE</b> <b>SOLVENTS</b>	disinfectant wipe over	
Display	Glass	Lint free damp cloth <b>DO NOT USE</b> <b>SOLVENTS</b>	Mild liquid disinfectant wipe over	N/A

Cleaning/Disinfecting/Sterilising - Recommendations Chart

PART	MATERIAL	CLEANING	DISINFECTING	STERILISING
Screen Surround	(ABS)	Lint free damp cloth <b>DO NOT USE SOLVENTS</b>	Mild liquid disinfectant wipe over	N/a
Keypads	(ABS)	Lint free damp cloth <b>DO NOT USE SOLVENTS</b>	Mild liquid disinfectant wipe over	N/A
Flowhead tube	Silicone-rubber	Mild detergent flush with clean water. Dry thoroughly	Mild disinfectant flush with clean water. Dry thoroughly	Cold liquid recommended. Autoclaving possible.
Flowhead cone	Acetal	Mild detergent flush with clean water	Mild disinfectant flush with clean water. Dry thoroughly	Cold liquid recommended. Autoclaving possible.
Flowhead resistive element	ABS/ Stainless steel mesh	<b>DISPOSABLE, CHANGE MONTHLY OR WHEN SOILED RECALIBRATE AFTER REPLACING ELEMENT</b>		

**DISASSEMBLING THE FLOWHEAD FOR CLEANING, DISINFECTING AND STERILISING**

1. Disconnect the FLOWHEAD from the FLOWHEAD tube.
2. Grip the resistive element in one hand and pull the cone off with the other.
3. Discard resistive element if soiled.
4. Clean as described in Cleaning/Disinfecting/Sterilising. **IMPORTANT: ENSURE THAT NO LIQUID REMAINS IN THE HOLES, GROOVES OR PITOT TUBE OF THE BODY.**
5. After cleaning etc. check the FLOWHEAD RINGS for damage and see that they are correctly positioned in the grooves.
6. Fit new resistive element and push firmly home, reconnect pressure tubes. Remember to re-calibrate when fitting a new resistive element.

9.  
TECHNICAL  
DATA LIST

Flow detection principles:	Lilly type pneumotachograph
Volume measurement:	Flow integration
Accuracy:	Volume - $\pm 3\%$ or $\pm 50$ ml whichever the greater. Flow - $\pm 3\%$ (up to 15L/S) at recommended operating temperature range
Max. displayed volume:	8 litres
Max. displayed flow rate:	15 litres/sec.
Max. test duration (FVC):	20 secs.
Back pressure:	<0.2 kPa/litre/sec. complies with or exceeds ATS, ACCP and ECCS standards
Flowhead cleaning:	Cold liquid recommended.
Printer paper:	Thermally sensitive
Printer speed:	20 lines/minute
Characters per line:	40 max.
Display:	LCD graphics panel 240X64 pixels
Microprocessor:	Intel 80188
Data entry:	Discrete key switches
Recommended operating temperature range:	20-30 degrees C (60-85 degrees F)
Operating voltage range:	115V AC $\pm 15\%$ or 230V AC $\pm 15\%$
Operation frequency range:	50-60Hz
Safety standards:	Conforms to IEC 601-1, BS 5724
Size:	300X250X130mm (WDXH) Nett 540X380X160mm (WDXH) Gross

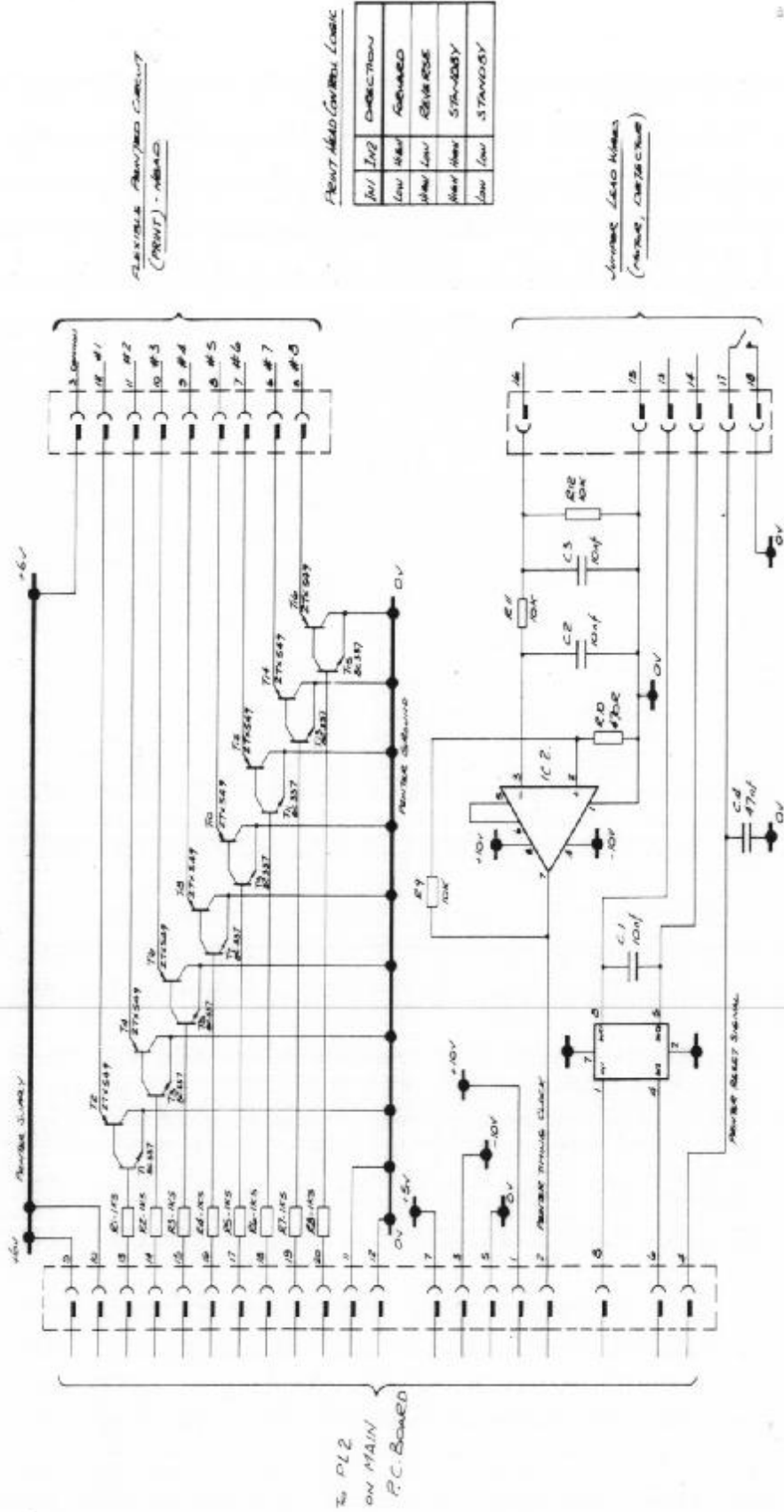

FIG. 9. PRINTER BOARD CIRCUIT DIAGRAM

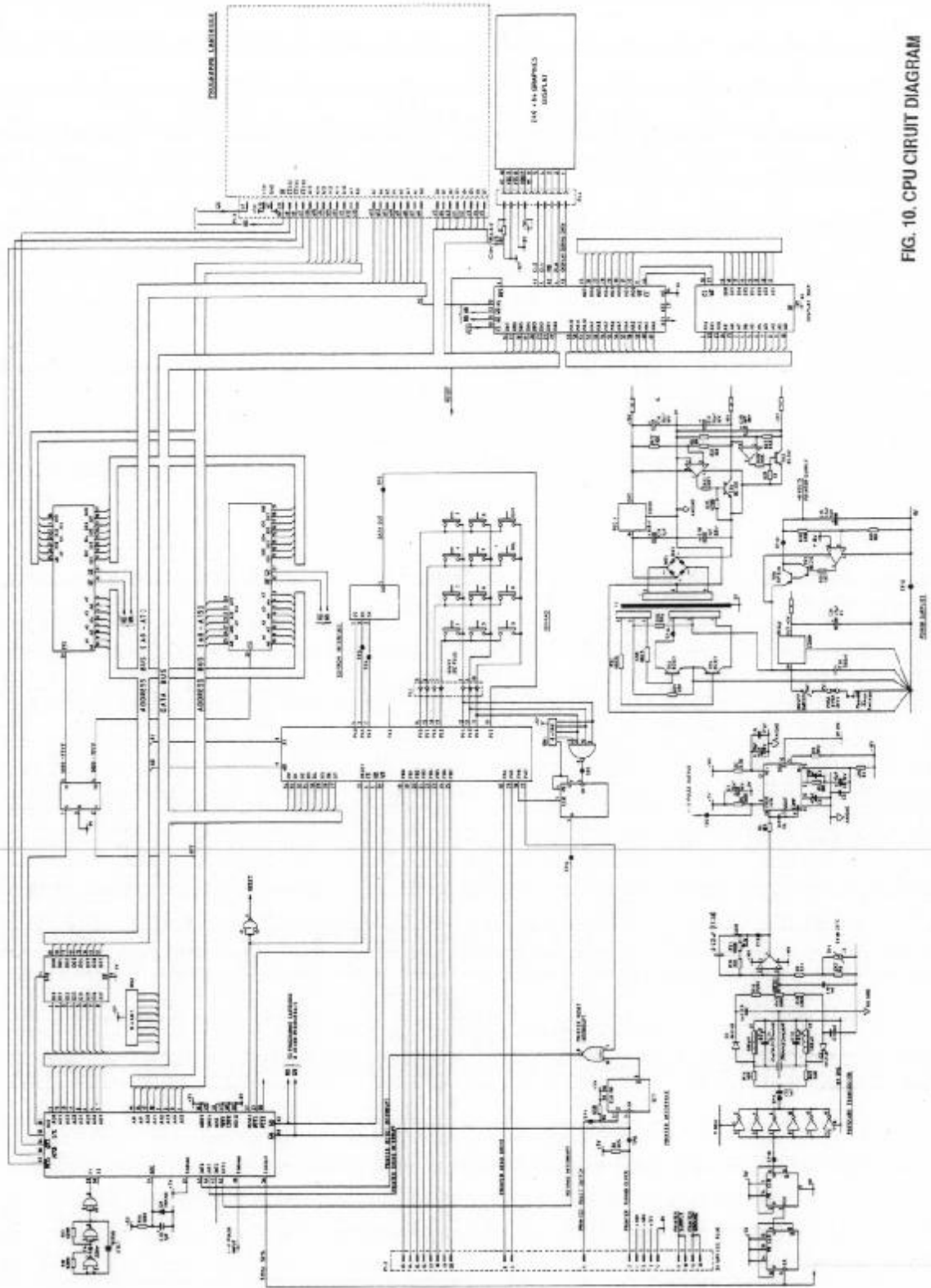

FIG. 10. CPU CIRCUIT DIAGRAM

#### **ONE YEAR GUARANTEE AND CUSTOMER SERVICE:**

SERVICE AND REPAIRS should be carried out only by the manufacturer, the approved importer or by Service Agents specifically approved by VITALOGRAPH LIMITED. There are no user serviceable components inside the equipment.

#### **Terms of Guarantee**

Subject to the conditions listed below, Vitalograph Ltd., (hereinafter called the Company) guarantee to repair or at its option replace any component thereof, which, in the opinion of the Company is faulty or below standard as a result of inferior workmanship or materials.

#### **The conditions of this Guarantee are:-**

1. This Guarantee shall only apply to alleged defects or faults which are notified to the Company or to its accredited agent within 1 year of the date of purchase of the equipment.
2. This Guarantee does not cover any faults caused by accident, misuse, neglect, tampering with the equipment, or any attempt at adjustment or repair other than by the accredited agent of the Company.
3. If a defect occurs please contact the supplier from whom it was purchased for advice. The Company does not authorize any person to create for it any other obligation or liability in connection with Vitalograph® equipment.
4. This Guarantee is not transferable and no person, firm or company has any authority to vary the terms or conditions of this Guarantee.
5. This Guarantee is offered as an additional benefit to the Consumer's statutory rights and does not affect these rights in any way.

## **10. GUARANTEE AND CUSTOMER SERVICE**