

SERVICE MANUAL

SEGMENTATION SYSTEM

Model

MS930A, MS930E

MS940A, MS940E

MS950A, MS950E

MS960A, MS960E

MS970A, MS970E

No. CAT.MS950SM1.0E
ISSUE 1 MARCH 2002

Important Notes

*** WARNING ***

**Do not open the covers. Risk of electric shock exists.
Warranty may be voided if the covers are opened.**

*** WARNING ***

**Do not operate this machine in close proximity to any person
with a pacemaker or to any sensitive electronic apparatus.
The recommended minimum safety distance is 12 feet (3.6 m).**

1. Safety notices:

This machine generates high-level power of 40.68 MHz radio-frequency (RF). Users are requested to be cautious of potential electric shock or hazard.

- Do not operate the machine without the protectors on the sealing heads.
- Do not insert fingers into a sealing head.
- Always turn the power switch off before cleaning the machine.
- Only authorized and trained personnel should remove covers.

2. Installation:

Nominal AC mains voltage of the models MS930A-970A is 100-120 volts 50/60Hz, and operational voltage range is 90-132 volts.

Nominal AC mains voltage of the models MS930E-970E is 200-240 volts 50/60Hz, and operational voltage range is 180-264 volts.

3. Cleaning:

- (1) Always keep the sealing head area clean and dry. If the sealing heads become wet or dirty, arcs may appear during sealing. If an arc appears, clean the sealing heads and let them dry thoroughly.
- (2) Use a soft cloth and mild detergent to clean the machine. After cleaning, wait a few minutes until the area cleaned is completely dried. Do not use paint thinner, benzene, solvent or any strong detergent.
- (3) Avoid using or leaving the machine in a location where temperature is higher than 50 °C (122 °F). Keep it away from any heating source or direct sunlight.

Contents

	page
Important Note	i
Contents	ii
List of Figures	iii
1. Introduction	1-1
1-1. General	1-1
1-2. Feature	1-3
1-3. Specification	1-4
2. Appearance and Function	2-1
2-1. Control Unit	2-1
2-2. Segmentation Unit	2-4
3. System Description	3-1
3-1. General	3-1
3-2. Control Board	3-3
3-3. I/O Board	3-3
3-4. Power Distribution Board	3-3
3-5. Power Supply Unit	3-3
3-6. Filter Board	3-3
3-7. RF Board	3-4
3-8. Distribution Board	3-5
3-9. Sealing Head Unit	3-5
3-10. Switch Board	3-6
3-11. Trigger Board	3-6
3-12. Matching Board	3-6
4. Standard Operating Procedure	4-1
4-1. Operation Mode	4-1
4-2. Operation in Local Mode	4-4
4-3. Operation in Remote Switch Mode	4-4
4-4. Operation in Remote Circuit Mode	4-4
4-5. Operation in Remote Command Mode	4-4
5. Maintenance and Troubleshooting	5-1
5-1. Precaution	5-1
5-2. Test Equipment	5-2
5-3. Troubleshooting Procedure	5-3
5-4. Adjustment of Variables	5-7
5-5. Fixtures for Remote Mode Control	5-9
5-6. Adjustment of RF	5-11
5-7. Cleaning Sealing Head	5-13

	page
6. Schematic Diagram	6-1
7. Technical Illustration	7-1
8. Parts List	8-1

List of Figures

[Figure 1-1]	Segmentation system MS950	1-2
[Figure 2-1]	Control unit	2-1
[Figure 2-2]	Segmentation unit	2-4
[Figure 3-1]	Overall system block diagram	3-2
[Figure 3-2]	RF board functional block diagram	3-4
[Figure 3-3]	Sealing head unit functional block diagram	3-5
[Figure 5-1]	Troubleshooting flow chart	5-4
[Figure 5-2]	Remote control scheme	5-9
[Figure 5-3]	RF test set-up	5-11
[Figure 6-1]	System wiring diagram	6-2
[Figure 6-2]	Control board schematic diagram	6-4
[Figure 6-3]	I/O board schematic diagram	6-8
[Figure 6-4]	RF board schematic diagram	6-9
[Figure 6-5]	Filter board schematic diagram	6-10
[Figure 6-6]	Power distribution board schematic diagram	6-11
[Figure 6-7]	Distribution board schematic diagram	6-12
[Figure 6-8]	Switch board schematic diagram	6-13
[Figure 6-9]	Trigger board schematic diagram	6-14
[Figure 6-10]	Matching board schematic diagram	6-15
[Figure 7-1]	Exploded view of MS950 Control unit	7-2
[Figure 7-1]	Exploded view of MS950 Segmentation unit	7-3
[Figure 7-2]	Control board layout	7-4
[Figure 7-3]	I/O board layout	7-5
[Figure 7-4]	RF board layout	7-6
[Figure 7-5]	Power distribution board layout	7-7
[Figure 7-6]	Distribution board layout	7-8
[Figure 7-7]	Trigger board layout	7-9
[Figure 7-8]	Matching board layout	7-9
[Figure 7-9]	Switch board layout	7-9
[Figure 7-10]	Filter board layout	7-9



1. Introduction

1-1. General

This Service Manual covers all technical information of Segmentation Systems MS930A/E - MS970A/E for servicing and maintenance of the machines.

The model numbers of Segmentation System denote the number of sealing head, and the voltage range of AC main.

Model number	Number of sealing head	AC mains voltage
MS930A	3	100-120 VAC
MS930E	3	200-240 VAC
MS940A	4	100-120 VAC
MS940E	4	200-240 VAC
MS950A	5	100-120 VAC
MS950E	5	200-240 VAC
MS960A	6	100-120 VAC
MS960E	6	200-240 VAC
MS970A	7	100-120 VAC
MS970E	7	200-240 VAC

This manual contains ;

1. Introduction
2. Appearance and Function
3. System Description
4. Standard Operating Procedure
5. Troubleshooting and Adjustment
6. Schematic Diagram
7. Technical Illustration
8. Parts List

The Segmentation Systems are precision electronic equipment. Troubleshooting and repair must be carried by authorized service personnel.

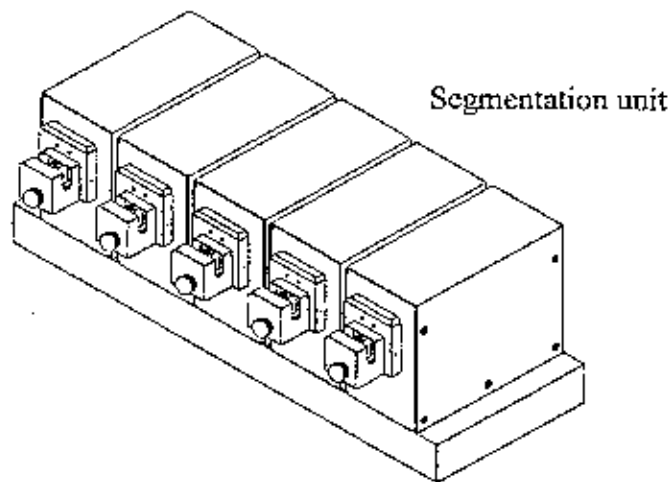
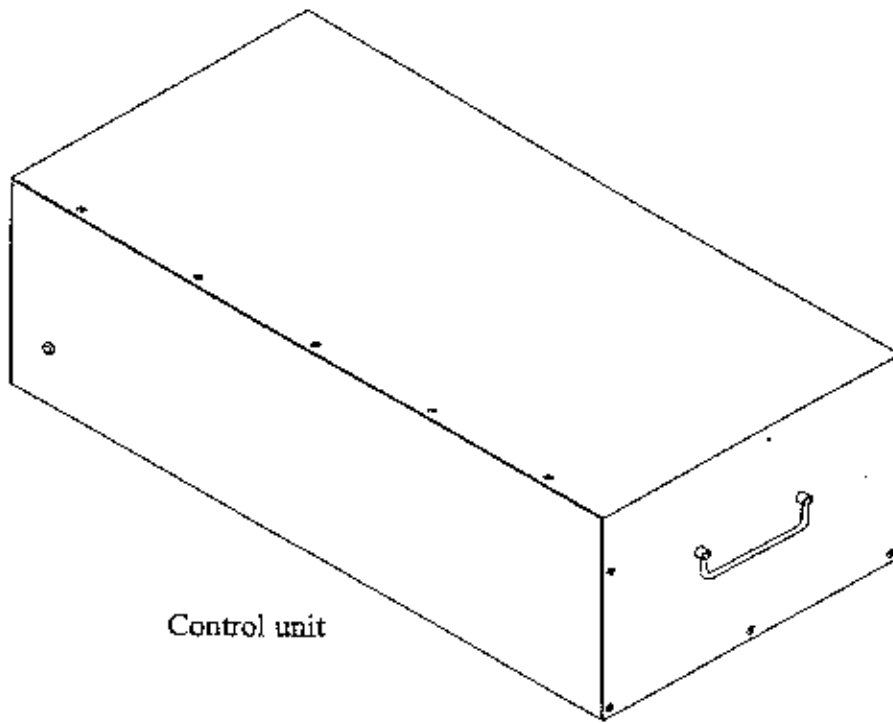

[Figure 1-1] Segmentation System MS950

1-2. Feature

The Segmentation System is a device to make multiple number of seals or segments of thermoplastic tubing in a few seconds. The machine generates high-level power of 40.68 MHz radio-frequency signal for a melting process called 'dielectric heating'. Tubing in the sealing heads melts quickly in about two to three seconds, and then cools to form seals.

The Segmentation System consists of a control unit, a segmentation unit and an inter-unit cable assembly. The segmentation unit can be installed up to 1.5 meters away from the control unit.

The system operates in one of four operation modes - local, remote switch, remote circuit and remote command modes. The system works in local mode if no connector is connected to the remote control connector on the rear panel of control unit.

Either remote switch mode or remote circuit mode is selected when a specially-made remote control connector is put on the 9-pin D-sub connector on the rear panel of control unit. Remote command mode is selected by software commands from an external computer circuit or a personal computer connected to the 9-pin D-sub connector on the rear panel of control unit with RS-232C serial communication.

The system has versatile features as the followings:

- The machine can be operated stand-alone, or be controlled by a circuit or a PC.
- The control unit can be placed under the table. It saves bench space.
- Distance between sealing heads is adjustable to one of 75-80-85-90 mm.
- Each sealing head can be enabled or disabled individually by switches or by PC.
- Time interval of sealing head starts is selectable between 60-160 milliseconds.
- Operation sequence of sealing heads is selectable - right to left or left to right.
- Timing of sealing head returns is selectable - simultaneously or individually.
- Thickness of seals can be adjusted.
- Indication lamp blinks and buzzer beeps in case of improper operation.
- The event counter on rear panel counts number of sealing cycles done.

1-3. Specification

- (1) System configuration : control unit, segmentation unit, inter-unit cable
- (2) Operation modes : local, remote switch, remote circuit, remote command
- (3) Operation frequency : 40.68 MHz
- (4) Overall sealing time : 1 - 3 seconds
- (5) Available tubing size : 2 - 6 millimeters in diameter
- (6) AC mains voltage

Model	MS930A	MS940A	MS950A	MS960A	MS970A
Nominal voltage	100-120 VAC, 50/60 Hz, single phase				
Working voltage	90-132 VAC, 47-63 Hz, single phase				
Power consumption	600 W	800 W	1000 W	1200 W	1400 W
Current rating	6 A	8 A	10 A	12 A	14 A

Model	MS930E	MS940E	MS950E	MS960E	MS970E
Nominal voltage	200-240 VAC, 50/60 Hz, single phase				
Working voltage	180-262 VAC, 47-63 Hz, single phase				
Power consumption	600 W	800 W	1000 W	1200 W	1400 W
Current rating	3 A	4 A	5 A	6 A	7 A

- (7) Over-current protection : By recoverable circuit breaker
- (8) Indication lamps
 - Control unit : POWER ON (green)
 - Segmentation unit : READY (green), SEALING (red)
- (9) Alarms : audible indication by buzzer, visual indication by lamps
- (10) Dimension and weight

Model	MS930A/E	MS940A/E	MS950A/E	MS960A/E	MS970A/E
<u>Control unit</u>					
- Size, W-H-D [mm]	406-200-310	518-200-310	630-200-310	742-200-310	854-200-310
- Weight [Kg]	9.5	10.5	11.5	12.5	13.5
<u>Segmentation unit</u>					
- Number of head	3	4	5	6	7
- Size, W-H-D [mm]	255-155-210	345-155-210	435-155-210	525-155-210	615-155-210
- Weight [Kg]	7.5	9.0	10.5	12.0	13.5
- Set distance [mm]	75,80,85,90	75,80,85,90	75,80,85,90	75,80,85,90	75,80,85,90

- (11) Inter-unit cable
 - RF Cable : RG-58, 1.8 meters (6 feet) long, BNC-male at both ends
 - Data Cable : 1.8 meters long, 37-pin D-Sub connectors at both ends
- (12) Communication parameters
 - Baud rate: 19200 bps
 - Data bits: 8
 - Stop bits: 1
 - Parity: None
 - Flow control: None
- (13) Temperature characteristics
 - Operating : 0 ° ~ 40 °C (32 ° ~ 104 °F)
 - Storage : - 20 ° ~ 70 °C (- 4 ° ~ 158 °F)

2. Appearance and Function

2-1. Control Unit (MS950A/E shown)

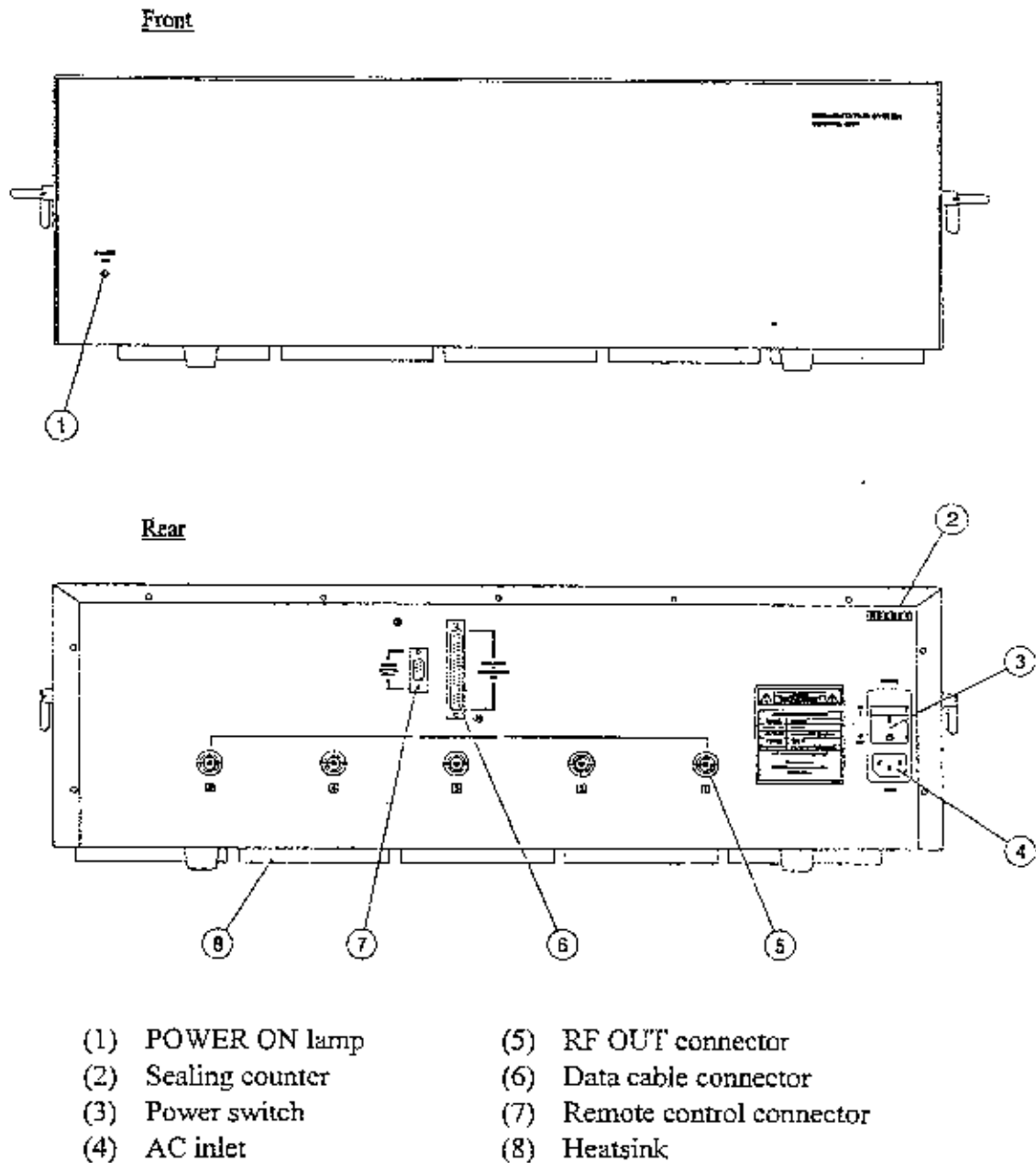

[Figure 2-1] Control Unit

The control unit contains power supplies, RF generator boards and control circuit board. Each power supply unit supplies 12 volts DC current to each RF generator board that generates 40.68 MHz RF power. RF powers go to the segmentation unit through coaxial cables in the inter-unit cable assembly.

The power switch ⁽³⁾ is located on the rear panel. When it is turned on, the POWER ON lamp ⁽⁴⁾ lights. The power switch module contains a recoverable circuit breaker that trips off when an over-current condition occurs in the system. There is no other control on the control unit.

Connections with the segmentation unit are made from rear panel. An end of each cable in inter-unit cable assembly is plugged at RF OUT connectors ⁽⁵⁾ and data cable connector ⁽⁶⁾. Remote control connector ⁽⁷⁾ is used only when the machine is operating in remote mode.

A cycle of sealing process starts by a signal from the segmentation unit given through the inter-unit cable, or by a signal from a remote control device connected at the remote control connector. The control unit feeds RF powers to all sealing head units for a determined period of time, as well as it controls movement of each sealing head. The sealing counter ⁽²⁾ counts up by 1 at each one cycle of sealing process.

Upon receiving start signal, the sealing heads start not at same time but one by one in series. Time interval between start of one sealing head and start of the next sealing head can be selected between 60-160 milliseconds with 20 milliseconds step. Operation sequence of sealing heads can be also selected, to start them from the right head to the left head, or from the left head to the right head.

Return timing of sealing heads can be selected too. Each sealing head can be returned individually at the moment when sealing ends at that sealing head unit, or all sealing heads can be returned simultaneously when the last working sealing head ends its job. Each sealing head can be enabled or disabled individually by switches on the control circuit board, as well as by software command if the machine works in remote mode. Default factory settings and adjustment procedures are found in Section 5-2.

The machine operates in one of four operation modes: local, remote switch, remote circuit and remote command modes. Power-on default is local mode if no connector is connected on the remote control connector. Details are found in Section 4.

When sealing is not made at a sealing head, audible and visual alarms are activated. Alarm condition is set up when any sealing head has not made seal in 3 seconds from start due to circuit failure. Alarm continues until the trigger lever at #1 sealing head is released by removing tubing.

In alarm condition, the followings take place:

- (1) The green POWER ON lamp on the front panel of control unit flashes.
- (2) Beeps sound.
- (3) Only in remote command mode operation, a status code among \$A,2* - \$E,2* is displayed. For example, when # 3 head does not work, \$C,2* will be given.

Not having alarms does not mean that all seals made are perfect. Alarm feature is provided not to decide automatically that all seals have been made perfect or incomplete, but to detect circuit failure to make the machine stop before starting the next cycle of sealing operation.

2-2. Segmentation Unit
(MS950A/E shown)

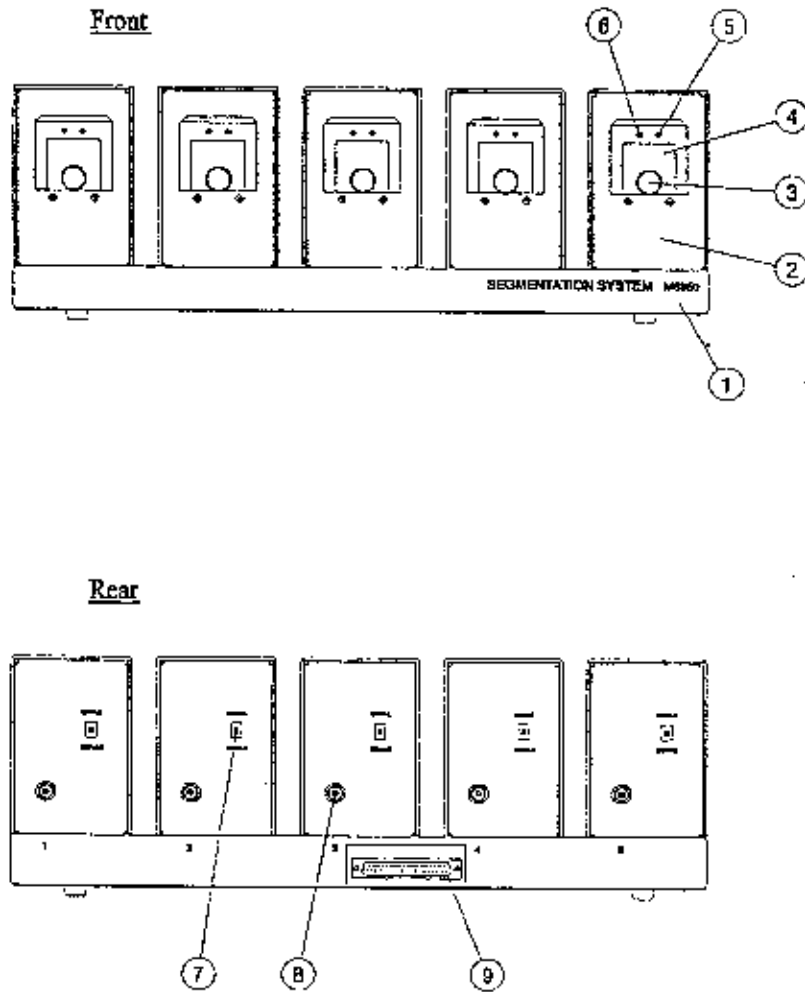

- | | |
|-----------------------|---------------------------|
| (1) Base plate | (6) READY lamp |
| (2) Scaling head unit | (7) ENABLE/DISABLE switch |
| (3) Protector screw | (8) RF IN connector |
| (4) Head protector | (9) Data cable connector |
| (5) SEALING lamp | |

[Figure 2-2] Segmentation Unit

The segmentation unit has all sealing head units⁽²⁾ and a signal distribution board in the base plate⁽¹⁾. All sealing head units are identical in configuration, but only the trigger lever in the sealing head unit mounted at #1 position is active and another trigger levers are in inactive state.

The trigger lever in #1 sealing head unit has two features. In local mode of operation, a cycle of sealing starts when it is depressed. In any one of three remote modes, it senses presence of tubing in #1 sealing head unit, then makes control circuit be ready to accept a remote start command to be given by a remote start switch, a remote start circuit or a remote control computer only when it detects tubing has been loaded in the #1 sealing head.

Mounting distances between sealing head units are adjustable at 75, 80, 85 or 90 mm. Users can adjust the distances as necessary.

An ENABLE/DISABLE selector switch is prepared on the rear panel of each sealing head unit. If the selector switch is selected at DISABLE, the sealing head unit does not work even if an ENABLE command is given in remote command mode.

On each sealing head units are two LED indication lamps. The green READY lamp⁽⁶⁾ is turned on when the ENABLE/DISABLE selector is set at ENABLE position. The red SEALING lamp⁽⁵⁾ is turned on only while sealing is being done. Both lamps will be off if the ENABLE/DISABLE selector switch is set at DISABLE position.

The head protectors⁽⁴⁾ should be placed securely all the time with protector screws⁽³⁾. Risk of electric shocks at the sealing head may exist if the protector is removed.

Behind the head protector are sealing head section and the trigger lever. Pressing the trigger lever initiates a cycle of sealing process. The moving part of sealing head comes out to squeeze tubing, and then RF power is applied. Tubing melts in second. After tubing melted and hardened again, the moving head retreats automatically.

3. System Description

3-1. General

The Segmentation System consists of the control unit, the segmentation unit and an inter-unit cable assembly.

The control unit contains one control circuit board and 3 - 7 pieces of power supply and RF board, depending on the model. E.g., MS950A/E has 5 power supplies and RF boards. The segmentation unit has same number of sealing head unit and a signal distribution board in the base plate. All sealing head units are identical in configuration, but only the trigger lever in the sealing head unit mounted at #1 position works.

The inter-unit cable assembly is a bundle of data cable and RF coaxial cables.

Refer to [Figure 3-1] to find overall system configuration.

The control board in control unit contains all logic circuits and timing gates. It receives trigger command signal from #1 sealing-head unit, and controls overall function of this equipment. RF board assemblies locate in control unit, which are high-power RF oscillator-amplifiers generating RF power, and sends RF power to all sealing-head units through inter-unit cable assembly.

Each sealing-head unit consists of a solenoid, sealing electrode, matching board assembly, trigger board assembly, micro-switches and a ENABLE/DISABLE switch. The ENABLE/DISABLE selector switch is prepared on the rear panel of each sealing head unit. If the selector switch is selected at DISABLE, the sealing head unit does not work even if an ENABLE command is given in remote command mode. Matching board assembly has an impedance transformer. Trigger board assembly has a trigger micro-switch and two indication lamps.

Following paragraphs describe theory and function of each assembly in detail.

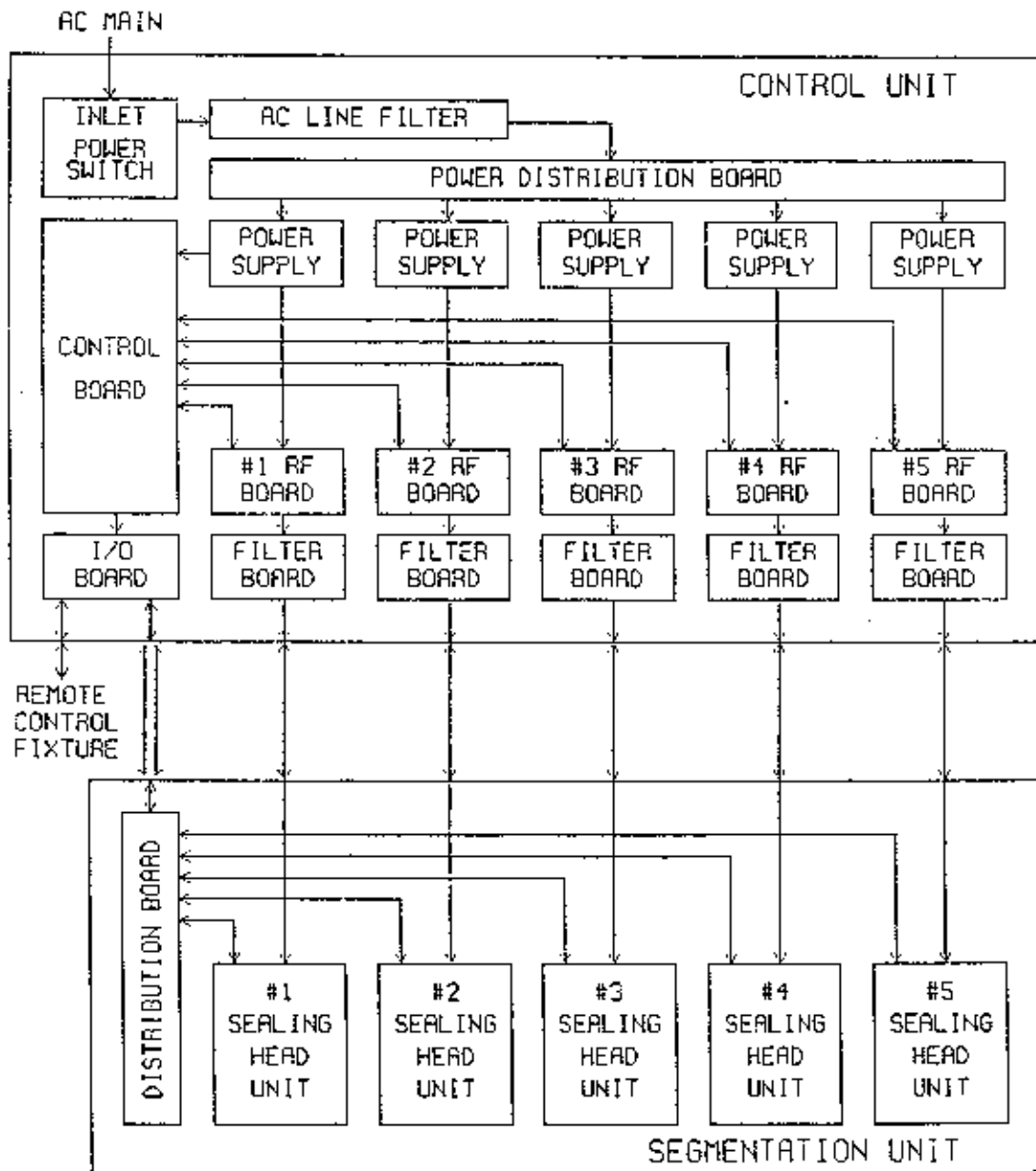

[Figure 3-1] Overall System Block Diagram

3-2. Control Board

Control board is a microprocessor-based circuit and has eight identical channels of control circuitry. The board is powered by #1 power supply unit.

Sealing operation starts by a trigger signal, either come from the trigger switch in #1 sealing head unit or given by command at a remote control mode. The microprocessor generates all timings to turn each RF board on and off, and to make each solenoid work. Working timing and sequence of each sealing head unit are adjustable at switches SW1 and SW2 on the control board.

3-3. I/O Board

I/O board has EMI filters on each signal lines and two opto-couplers for isolation of remote control fixtures.

3-4. Power Distribution Board

This board distributes AC mains to eight identical channels. It has a buzzer on the board.

3-5. Power Supply Unit

Power supply units are switching-mode power supplies. Each unit takes either 200-240 VAC or 100-120 VAC as input, and provides regulated voltage of 12 VDC as output. The power supply units in an A-suffix model take 100-120 VAC only, and the ones in an E-suffix model take 200-240 VAC only.

3-6. Filter Board

Filter board has RF filters to decrease high-order harmonic frequency components.

3-7. RF Board

RF board comprises an oscillator, drive amplifier stages and power amplifier, and filter networks. [Figure 3-2] represents the functional block diagram of RF board.

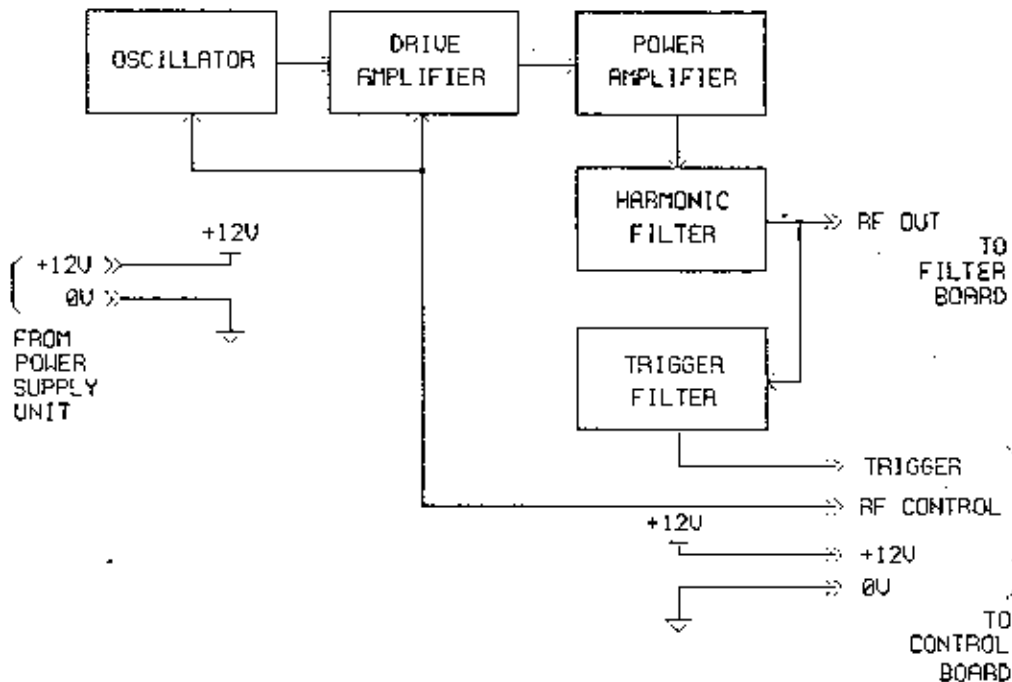

[Figure 3-2] RF board Functional Block Diagram

A crystal oscillator generates stable RF signal when control command is applied. The signal is amplified at drive amplifiers, then fed to power amplifier stage. It works only when control command is applied.

A strong RF push-pull power amplifiers amplify RF power. The power is then supplied to scaling-head through filters and impedance transformer. Harmonic filter networks filter harmonic spurious frequency components. With the filter networks, harmonic frequency spectrum other than 40.680 MHz are all reduced to below sufficient level.

3-8. Distribution Board

Command data and solenoid powers are distributed to eight identical channels. #1 channel only has the trigger command line.

3-9. Sealing Head Unit

Sealing head unit comprises sealing electrode, solenoid, trigger board assembly, trigger micro-switch, limit micro-switch, matching board and switch board.

[Figure 3-3] represents the functional block diagram of sealing head unit.

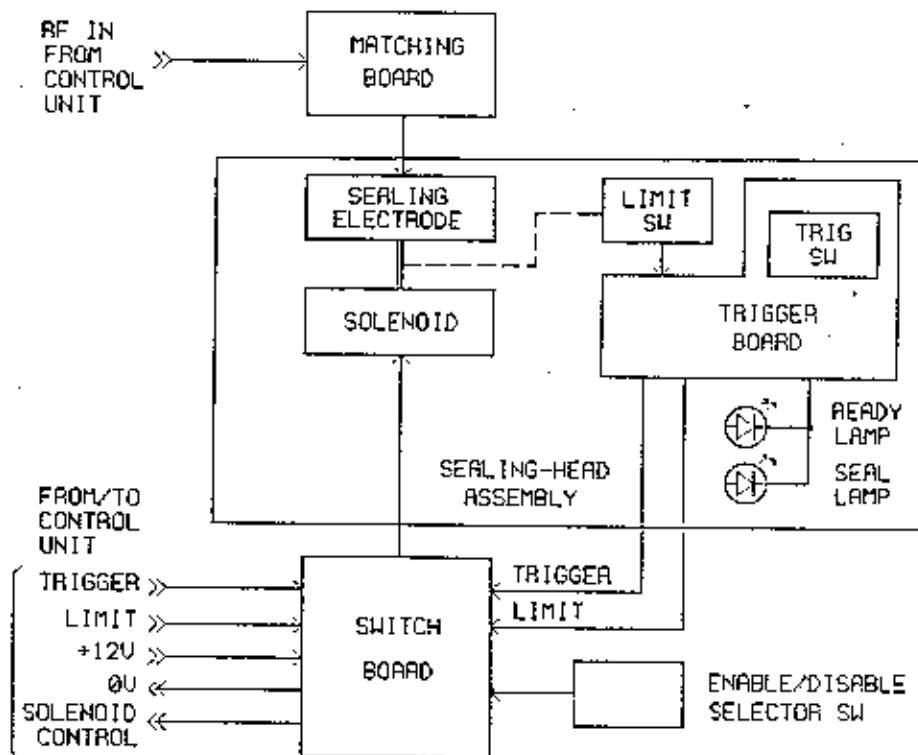

[Figure 3-3] Sealing head Unit Functional Block Diagram

The trigger lever in #1 sealing head unit has two features. In local mode of operation, a cycle of sealing starts when it is depressed. In any one of three remote modes, it senses presence of tubing in #1 sealing head unit, then makes control circuit be ready to accept a remote start command to be given by a remote start switch, a remote start circuit or a remote control computer only when it detects tubing has been loaded in #1 sealing head.

An ENABLE/DISABLE selector switch is prepared on the rear panel of each sealing head unit. If the selector switch is selected at DISABLE, the sealing head unit does not work even if an ENABLE command is given in remote command mode.

On each sealing head units are two LED indication lamps. The green READY lamp is turned on when the ENABLE/DISABLE selector is set at ENABLE position. The red SEALING lamp is turned on only while sealing is being done. Both lamps will be off if the ENABLE/DISABLE selector switch is set at DISABLE position.

When tubing melts, two parts of sealing head come close, hence the limit switch in the sealing head is depressed. This signal from limit switch goes to control board and turns RF power generation of the sealing head unit off.

3-10. Switch Board

An ENABLE/DISABLE selector switch is prepared on the switch board. If the selector switch is set at DISABLE, the sealing head unit does not work even if an ENABLE command is given in remote command mode.

3-11. Trigger Board

The Trigger board is mounted on sealing-head structure in the sealing-head unit. The board houses a trigger micro-switch and two LED indication lamps that display either READY or SEAL status.

3-12. Matching Board

The Matching board locates in the sealing-head unit. On the board is an impedance transformer called loading coil. It transforms RF board impedance to sealing-head impedance.

4. Standard Operating Procedure

4-1. Operation Mode

Four operation modes are available with this Segmentation System:

- Local mode
- Remote modes; (1) Remote switch mode
 (2) Remote circuit mode
 (3) Remote command mode

(a) Local Mode

Local mode is a mode that the machine operates by itself without any external device. Default mode is the local mode. A cycle of sealing operation is initiated by pressing the trigger lever at #1 sealing head unit. All the other trigger levers do not work at all.

(b) Remote Switch Mode

Remote switch mode is a mode that the machine is controlled by an external switch. When a connector, which should have been specially pre-wired and an external switch should have been wired to, is connected onto the remote control connector of the control unit, the machine works in remote switch mode.

In this mode, sealing starts by pressing the remote switch. Before the switch pressed, the trigger lever at #1 sealing head should have been pressed by tubing. If tubing is not loaded in #1 sealing head, sealing does not start. The trigger lever at #1 head senses presence of tubing, and then enables circuit to accept command given by the remote switch only when tubing has been loaded in #1 sealing head unit. All the other trigger levers do not work at all.

(c) Remote Circuit Mode

Remote circuit mode is a mode that the machine is controlled by an external signal. When a connector, which should have been specially pre-wired with a circuit, is connected onto the remote control connector of the control unit, the machine works in remote circuit mode.

In this mode, sealing starts by giving a signal from the remote circuit. Before the signal is given, the trigger lever at #1 sealing head should have been pressed by tubing. If tubing is not loaded in #1 sealing head, sealing does not start. The trigger lever at #1 head senses presence of tubing, and then enables circuit to accept command given by the remote circuit only when tubing has been loaded in #1 sealing head unit. All the other trigger levers do not work at all.

In remote circuit mode, a confirmation signal is given to the remote circuit to confirm that the sealing cycle has ended. If an indication lamp is prepared in the remote circuit, the lamp will act as followings:

- It is turned on when a sealing cycle ends, that means tubing can be taken out now.
 - It is turned off when tubing is loaded in #1, that means it's ready to start sealing.
- This mode is useful to use the machine in an automated production line.

(d) Remote Command Mode

Remote command mode is a mode that the machine is controlled by an external microprocessor circuit or a PC. For this mode of operation, a microprocessor circuit or a desktop PC is required. When the microprocessor circuit or the PC is connected onto the remote control connector through an RS-232C serial communication cable, operation mode of the machine is changed from local mode to remote command mode by software command from the microprocessor circuit or the PC.

In remote command mode, the machine is controlled by software command only. Sealing starts by start command only when the trigger lever at #1 head is depressed by tubing. If tubing is not loaded in #1 unit, scaling does not start. Trigger lever at #1 head senses presence of tubing, then enables circuit to accept the start command only when tubing has been loaded in #1 sealing head unit. When scaling has ended, confirmation commands are given to the external control computer.

a. Command List to control the system;

Command	Function
\$M,1*	Change system mode from local to remote command mode
\$M,0*	Change system mode from remote command to local (default)
\$A,1*	Enable #1 sealing head unit (default)
\$A,0*	Disable #1 sealing head unit
\$B,1*	Enable #2 sealing head unit (default)
\$B,0*	Disable #2 sealing head unit
\$C,1*	Enable #3 sealing head unit (default)
\$C,0*	Disable #3 sealing head unit
\$D,1*	Enable #4 sealing head unit (default)
\$D,0*	Disable #4 sealing head unit
\$E,1*	Enable #5 sealing head unit (default)
\$E,0*	Disable #5 sealing head unit
\$F,1*	Enable #6 sealing head unit (default)
\$F,0*	Disable #6 sealing head unit
\$G,1*	Enable #7 sealing head unit (default)
\$G,0*	Disable #7 sealing head unit
\$S,1*	Start sealing

Note 1 - All commands should be input with capital letters.

Note 2 - Enable/Disable selector switch should be set at ENABLE position in order that sealing head enable/disable control commands can work. When the selector

switch is set at DISABLE position, the sealing head unit remains in disabled condition and will not be enabled even if an enable command is given.

Note 3 - Another way to reset system mode to local is turning system power switch off and then on again, as power-on default mode is local mode.

b. Status Code List to indicate system operation;

Code	Occurrence
\$M,1*	When system mode is changed to remote command mode
\$M,0*	When system mode is returned to local mode
\$A,0*	When #1 sealing head unit is disabled
\$A,1*	When #1 sealing head unit is enabled
\$A,2*	When #1 sealing head unit has made incomplete sealing
\$B,0*	When #2 sealing head unit is disabled
\$B,1*	When #2 sealing head unit is enabled
\$B,2*	When #2 sealing head unit has made incomplete sealing
\$C,0*	When #3 sealing head unit is disabled
\$C,1*	When #3 sealing head unit is enabled
\$C,2*	When #3 sealing head unit has made incomplete sealing
\$D,0*	When #4 sealing head unit is disabled
\$D,1*	When #4 sealing head unit is enabled
\$D,2*	When #4 sealing head unit has made incomplete sealing
\$E,0*	When #5 sealing head unit is disabled
\$E,1*	When #5 sealing head unit is enabled
\$E,2*	When #5 sealing head unit has made incomplete sealing
\$F,0*	When #6 sealing head unit is disabled
\$F,1*	When #6 sealing head unit is enabled
\$F,2*	When #6 sealing head unit has made incomplete sealing
\$G,0*	When #7 sealing head unit is disabled
\$G,1*	When #7 sealing head unit is enabled
\$G,2*	When #7 sealing head unit has made incomplete sealing
\$S,1*	When sealing starts
\$S,0*	When sealing ends
\$R,1*	When tubing is loaded in #1 head, so system is ready to start sealing
\$R,0*	When tubing is removed from # 1 sealing head unit

Note 1 - At the moment when the power switch is turned on, the status codes \$A,1* through \$E,1* are given once.

Note 2 - The control command \$S,1* works only after the status code \$R,1* has been received.

4-2. Operation in Local Mode

- (1) Install the machine.
- (2) If a connector or a cable is connected to the remote control connector on the rear panel of control unit, remove it.
- (3) Turn on the power switch.
- (4) Place tubing in sealing heads from the left to the right, and press the trigger lever in #1 sealing head.
- (5) When all green indication lamps are lit, remove tubing.

4-3. Operation in Remote Switch Mode

- (1) Install the machine.
- (2) Connect a remote switch fixture to the remote control connector.
- (3) Turn on the power switch.
- (4) Place tubing in sealing heads. The #1 trigger lever should be depressed.
- (5) Activate the switch in the fixture.
- (6) When all green indication lamps are lit, remove tubing.

4-4. Operation in Remote Circuit Mode

- (1) Install the machine.
- (2) Connect a remote circuit fixture to the remote control connector.
- (3) Turn on the power switch.
- (4) Place tubing in sealing heads. The #1 trigger lever should be depressed.
- (5) Let DC current flow between pin 7-pin 8 by circuits or by activating a switch.
- (6) When all green indication lamps are lit, remove tubing.
- (7) If required, use the confirmation signal at pin 1.

4-5. Operation in Remote Command Mode

If users would design specific remote control fixtures, various applications would be available with this mode. But the simplest way could be to use a personal computer as a remote controller. And available ready-made communication programs are the files terminal.exe and hypertrm.exe given by Microsoft with operating systems Windows 3.1/95/98/2000/ME. Terminal.exe in Windows 3.1 is better and more convenient to use for remote control of the machine.

As a demonstration of an application, described below are operation procedures with using the program file terminal.exe in a PC with Windows operating system.

- (1) Install the machine.
- (2) Connect a standard serial communication cable to the remote control connector and to the PC.
- (3) Turn on the computer, and run the file terminal.exe.
- (4) On menu bar, click Settings - Communications...
 In Communications dialog box, check communication parameters as;
 - Baud rate : 19200
 - Data bits : 8
 - Stop bits : 1
 - Parity : None
 - Flow control : None
 - Connector : a port among COM1 - COM4 that is available in your PC.
 (If you are not sure which COM port is available, try one by one until you don't get a 'Terminal - Error' message.)
- (5) On menu bar, click Settings - Terminal Preferences...
 In Terminal Preferences dialog box, check 'Local Echo' in Terminal Modes box.
- (6) Turn on the power switch of Segmentation System.
 All status codes indicating Enable/Disable selection of each sealing head are displayed once.
- (7) To change system mode from local to remote command mode, type in \$M,1*.
 All commands should be typed in capital letters. Do not press Enter key after command. On monitor screen, \$M,1*\$M,1* will be displayed. The first \$M,1* is an echo of the command that you have typed in, and the second \$M,1* is a status code that system replies.
- (8) Place tubing in sealing heads, and let #1 trigger lever be depressed.
 When #1 trigger lever is depressed, \$R,1* is displayed.
- (9) Start sealing by giving the command \$\$,1*.
 On monitor screen, \$\$,1*\$\$,1* will be displayed. The first \$\$,1* is an echo of the command that you have typed in, and the second \$\$,1* is a status code that system replies.
- (10) When sealing ends, status code \$\$,0* is displayed and all green lamps light.
 Remove tubing. Then status code \$R,0* is displayed.
- (11) Repeat sealing from paragraph (8) to (10).

Note 1 : The Enable/Disable selector switch on each sealing head unit should be set at ENABLE position in order that sealing head enable/disable control commands can work. Selection at Enable/Disable selector switch has priority over enable/disable control command.

When the selector is set at DISABLE position, a command \$A,1* - \$E,1* cannot turn the sealing head unit into enabled condition. When the selector is set at ENABLE position, a command \$A,0* - \$E,0* can turn the sealing head unit into disabled condition, and then a command \$A,1* - \$E,1* can turn the sealing head unit into enabled condition again.

Note 2 : The command \$M,0* changes system mode from remote command mode to local mode. Another way to change system mode to local is turning system power switch off and then on again, as power-on default mode is local mode.

Note 3 : To enter the command \$S,1* to start sealing, you should hit 5 keys every time. It is not an easy job to repeat 5 keys every time.

To do it simple, you can save the command in a 'Function' key in the program.

On menu bar, click Settings - Function Keys.... In Function Keys dialog box, you can set up to 8 function keys, and then only one stroke inputs a command once.

Note 4 : You can save the settings you have used in a configuration file to use later.

On menu bar, click File - Save As.... In File Save As dialog box, give a name for your file. File extension will be *.trm. When the file is called by clicking File - Open..., you will have same settings as before.

5. Maintenance and Troubleshooting

This Chapter describes how to check, adjust and troubleshoot the machine with proper test equipment.

Troubleshooting flow chart leads service personnel to a faulty assembly or to one or a few suspicious components. When a faulty assembly or component is isolated, it would be adjusted in accordance with the procedures in this chapter, or be replaced with a good one.

Followings are the topics covered in this chapter ;

- . Precautions for troubleshooting
- . Test equipment necessary
- . Troubleshooting flow charts
- . Adjustments of major characteristics
- . Cleaning of sealing-head section.

5-1. Precaution

When performing troubleshooting, keep following general precaution ;

- * Use proper test equipment and tools.
- * Be careful enough not to touch any AC main line.
- * Set a current limit at DC power supply to protect RF power transistor.
- * Prepare sufficient heatsink for RF board to avoid temperature increase.
- * When replacing a component, use proper rated component.
- * Be careful not to touch RF circuits and electrodes with your finger when RF is being generated. You may be shocked and burnt.

CAUTION

- Dangerous high voltage over a hundred volts may exist at RF circuits while RF is turned on.
- Finger may be burnt by induction heating if it's placed between two electrodes of sealing-head, or near RF transistors and transformers.

5-2. Test Equipment

Test equipment and tools listed below are necessary to do troubleshooting.

(1) Minimum test equipment and tools for troubleshooting ;

- . Multimeter
- . Regulated DC power supply (12 volts/20 amperes)
- . Oscilloscope (10 MHz)
- . Frequency counter (100 MHz)
- . RF power meter (100 MHz/200 Watts)
- . Screwdrivers (cross-tips, flat-tips)

(2) More test equipment necessary for complete troubleshooting ;





- . DC Ammeter (20 amperes)
- . Regulated DC power supply (12 V/20 A, with current-limiting feature)
- . Oscilloscope (100 MHz, dual-trace)
- . Spectrum analyzer (300 MHz)
- . Network analyzer (S-parameters, Impedance-curve display feature)
- . RF power meter (200 Watts, forward/reverse/effective powers)
- . RF dummy load (50 ohm, 100 W)
- . RF attenuator (60 DB)
- . Coaxial cables (RG-58, BNC male-BNC male)

5-3. Troubleshooting Procedure

The troubleshooting flow charts in [Figure 5-1] will guide service personnel to a faulty assembly or components that should be replaced or corrected. When a faulty assembly is isolated, it will be adjusted to correct state, or be replaced with a new good assembly. In case that service people have good knowledge in electronics, proper test equipment and components, they can troubleshoot to a single faulty component.

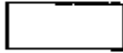
All technical documentation necessary for adjustments and troubleshooting are prepared in the Chapters 6, 7 and 8.

Legend of Troubleshooting Flow Chart

	Square	Action
	Diamond	Decision
	Circle	Connection to/from other branch.
	Vertical line	"YES" path
	Horiz. line	"NO" path

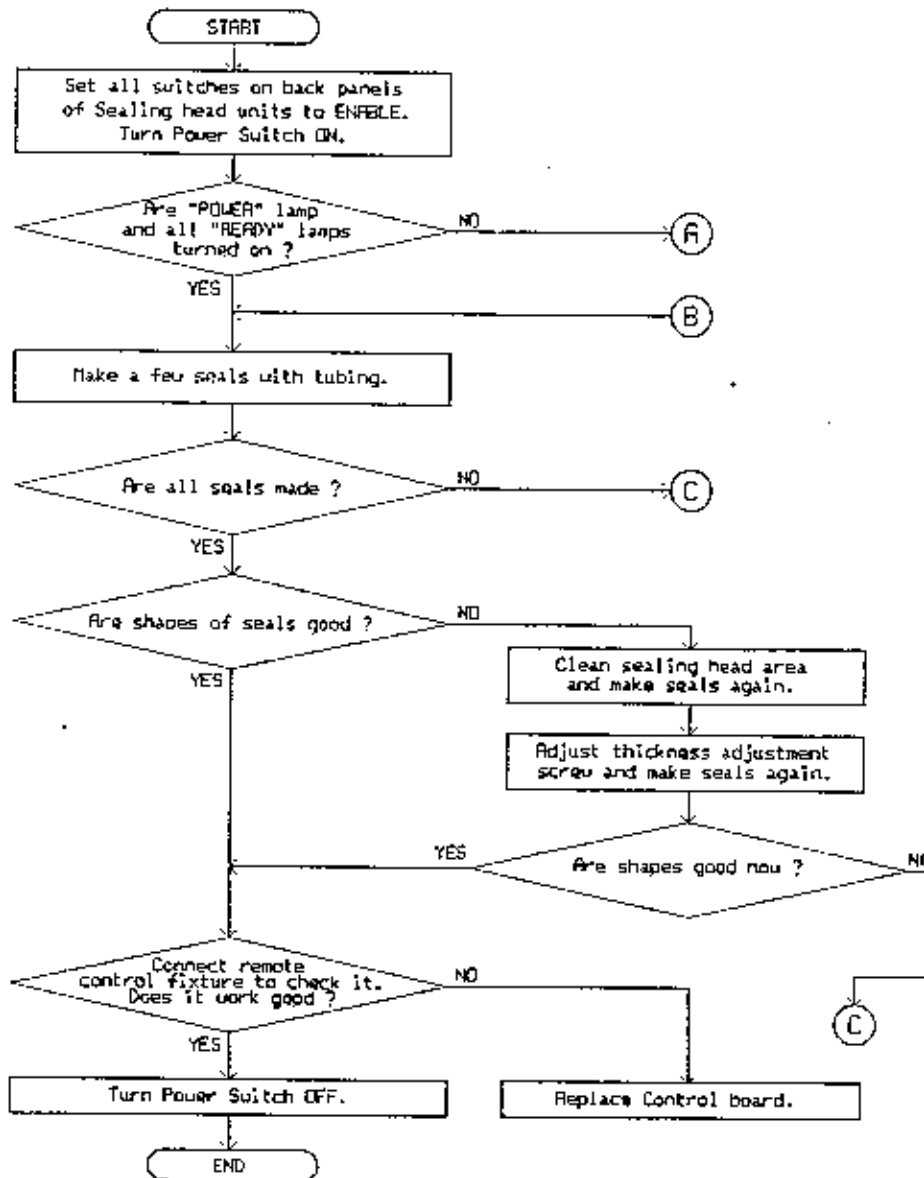

[Figure 5-1] Troubleshooting Flow Chart (Page 1/3)

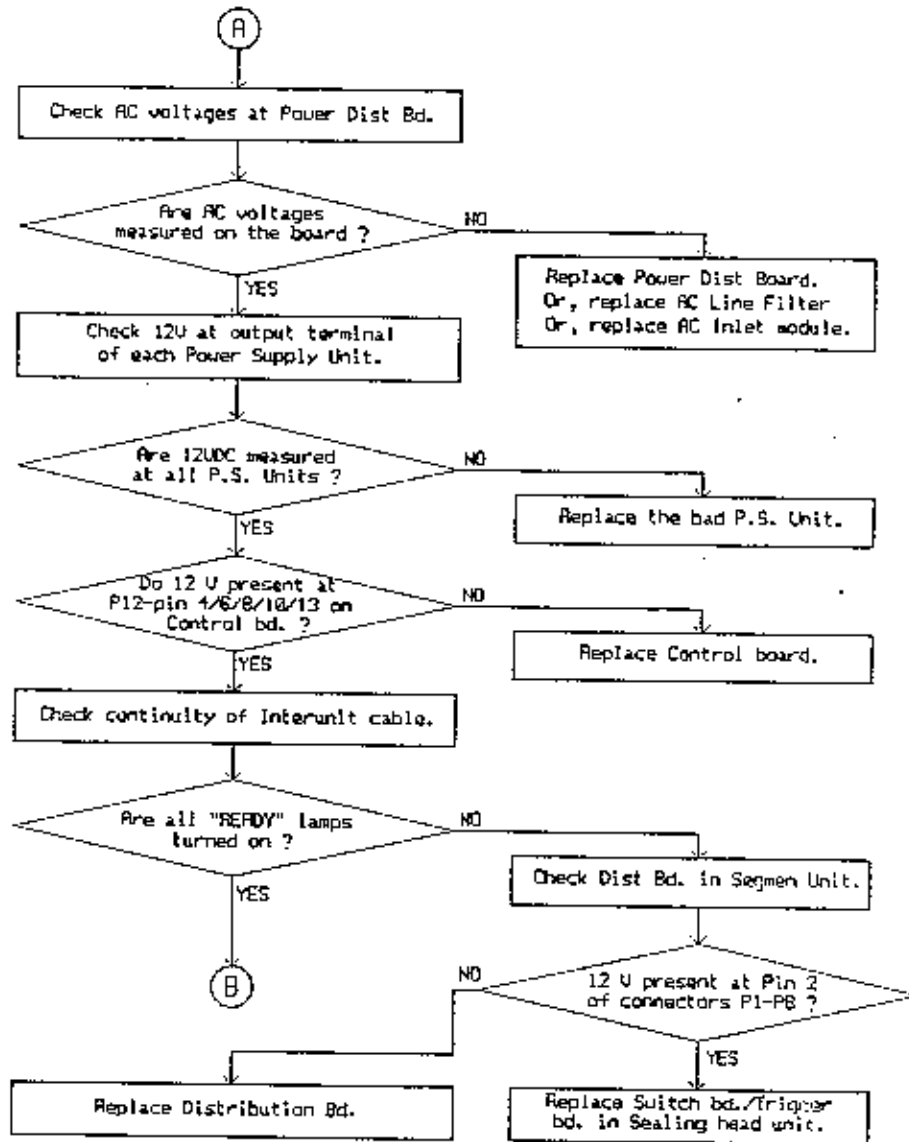

[Figure 5-1] Troubleshooting Flow Chart (Page 2/3)

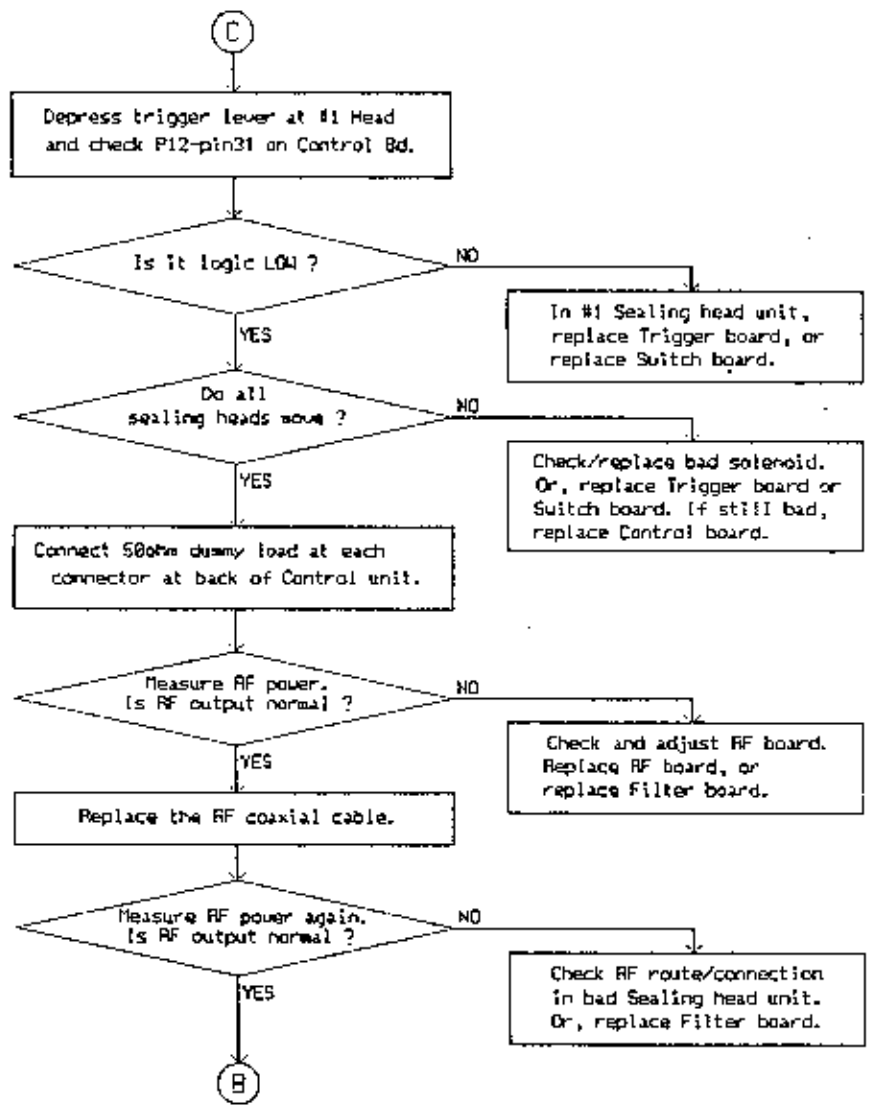

[Figure 5-1] Troubleshooting Flow Chart (Page 3/3)

5-4. Adjustment of Variables

On the control circuit board in the control unit are two 8-bit DIP-switch selectors, marked as SW1 and SW2. With these selectors, users can change working sealing head units, time interval of head starts, operation sequence of sealing heads, and timing of sealing head returns.

(1) Selection of working heads

SW2 is 8-bit DIP-switch. Each bit corresponds to each sealing head unit. Down position is ENABLE, and up position is DISABLE. Setting of each bit switch has to be matched with number of sealing head units used. For example, when #1 - 5 sealing head units will be used, it has to be set as the following;



If #3 sealing head will not be used in MS950 model, it should be as the following;



Factory setting is 'all head units at ENABLE'.

(2) Selection of time interval of head starts

Among 8-bit DIP-switch selectors of SW1, lower 6 bits are used for selection of time interval of head starts. Time interval of sealing starts between a sealing head and the next sealing head can be changed between 60-160 milliseconds by 20 milliseconds step. Only one bit should be positioned to the left. If two or more bits are set at left, the lowest bit will be acknowledged.

For example, to select 100 milliseconds interval, it has to be set as the following;

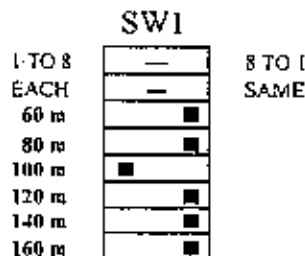

Factory setting is '100 mS'.

(3) Selection of operation sequence of sealing heads

Among 8-bits of SW1, the first high bit is used for selection of operation sequence of sealing heads. When the bit slide is set at left, sealing starts from #1 sealing head unit, then #2, then #3, (from right to left). When the bit slide is set at right, sealing starts from #5 sealing head unit, then #4, then #3, (from left to right). Factory setting is 'right' (starting from left head to right head).

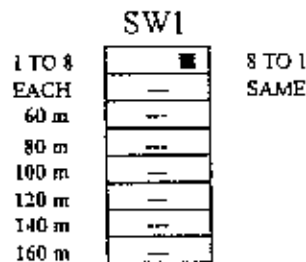

(4) Selection of timing of sealing head returns

Among 8-bits of SW1, the second high bit is used for selection of timing of sealing head returns. When the bit slide is set at left, each sealing head returns independently when sealing is done at the head. When the bit slide is set at right, all sealing heads return same time when sealing at all heads is done. Factory setting is 'left' (returning independently).

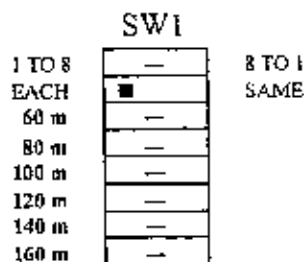

(5) Thickness adjustment

Thickness of seals can be adjusted in small range by adjusting a screw at each sealing head. Remove the head protector, and turn the screw at left of head counter-clockwise if seals should become thinner, or turn it clockwise if thicker seals are required. Turn the screw by only a quarter turn or less each time and check thickness variation, then repeat again, as this adjustment is quite sensitive.

(6) Set distance between sealing head units

Distances between two sealing head units can be set at either one of 75, 80, 85, 90 mm. To change mounting position of sealing head unit, two screws shall be disassembled at the bottom of segmentation unit.

5-5. Fixtures for Remote Mode Control

To operate the machine in one of three remote modes, a fixture should be prepared by users. Refer to [Figure 5-2] below.

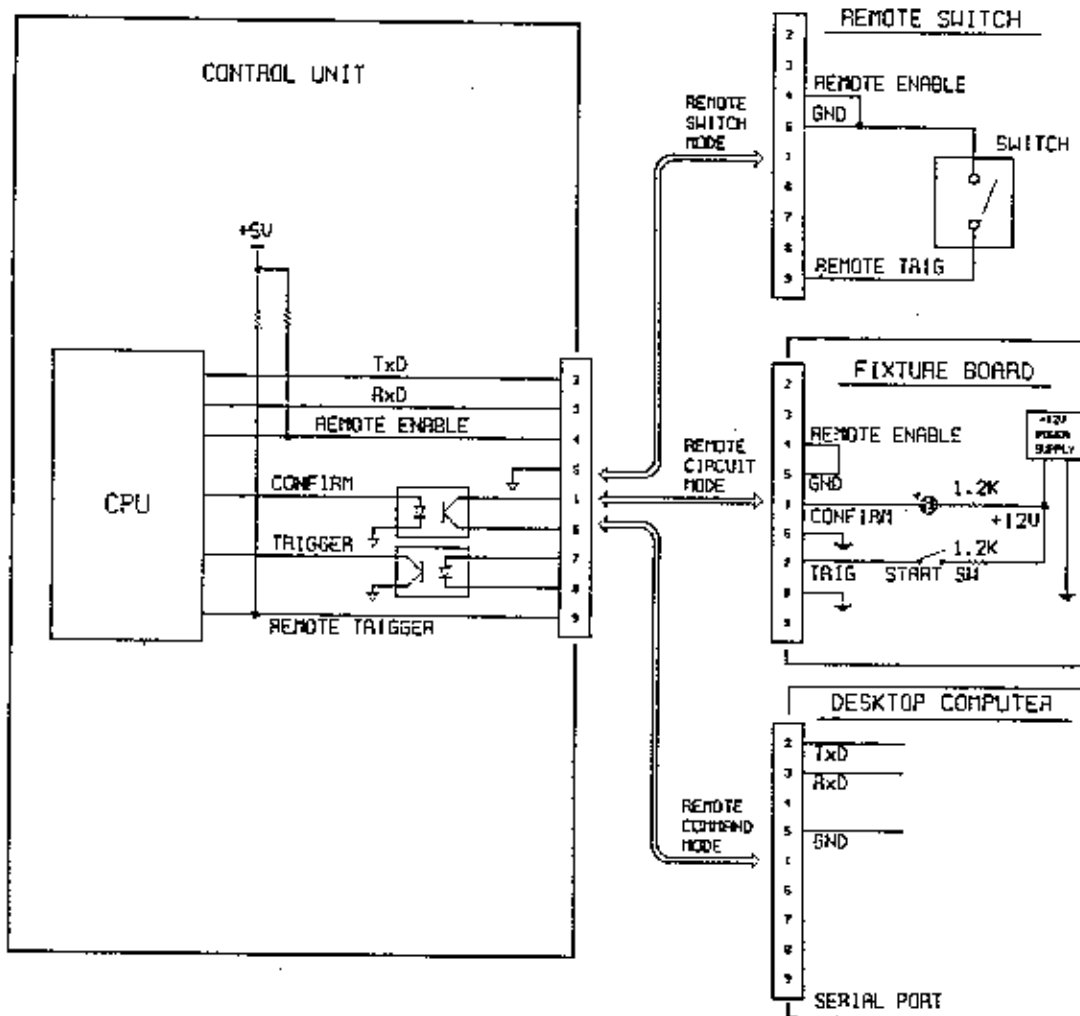

[Figure 5-2] Remote Control Scheme

The diagram is a conceptual drawing to give users technical understanding concerning interfaces between the machine and the fixture to be designed. Users shall prepare the fixtures in accordance with own specific needs and application.

a. Fixture for remote switch mode

A fixture for remote switch mode is simple to make. It requires a single-pole/single-throw (SPST) switch (e.g. a foot switch) and a 9-pin D-Sub male connector.

- (1) Solder the switch at Pin 9 and Pin 5 of the 9-pin D-Sub connector.
- (2) Solder to make short between Pin 4 and Pin 5 of the 9-pin D-Sub connector.

b. Fixture for remote circuit mode

A fixture for remote circuit mode will be a circuit board, and needs an external DC power source. With this fixture, the ground of the fixture can be isolated with the ground of the Segmentation System.

- (1) To turn on the opto-coupler chip in the machine, 5-10 mA DC current should be supplied between pin 7 (+) and pin 8 (-) of the 9-pin D-Sub connector.

Suggested serial resistance shall vary depending on power source voltage:

Source voltage	5 VDC	12 VDC	24 VDC
Resistance	300 - 560 ohm	1 - 1.8 Kohm	2 - 3.9 Kohm

- (2) A confirmation signal is given between pin 1 (collector) and pin 6 (emitter) of the photo-transistor in opto-coupler chip. Suggested serial resistance shall vary depending on power source voltage. A same resistor as above can be used.
- (3) Solder to make short between Pin 4 and Pin 5 at 9-pin D-Sub connector.

c. Fixture for remote command mode

For operation in remote command mode, a fixture may or may not be necessary. If users want to design a specific fixture for use in an automated production line, refer to Command List and Status Code List. All commands and status codes should be given in ASCII code format.

If users want to use a desktop personal computer as a remote controller, no fixture but a communication program is necessary. Users may design a communication program for own use. But it will be a convenient way to use an open program provided by the Microsoft. The file terminal.exe in Windows 3.1 or hypertrm.exe in Windows 95/98/2000/ME is a communication program good to use for this purpose.

Communication parameters should be set as the followings:

Baud rate : 19200 bps
Data bits : 8
Stop bits : 1
Parity : None
Flow control : None

5-6. Adjustment of RF

Following procedures describe standard check procedures for the RF circuitry. Refer to [Figure 5-3] below for test set-up, and schematic diagrams and board layout diagrams in Chapter 7.

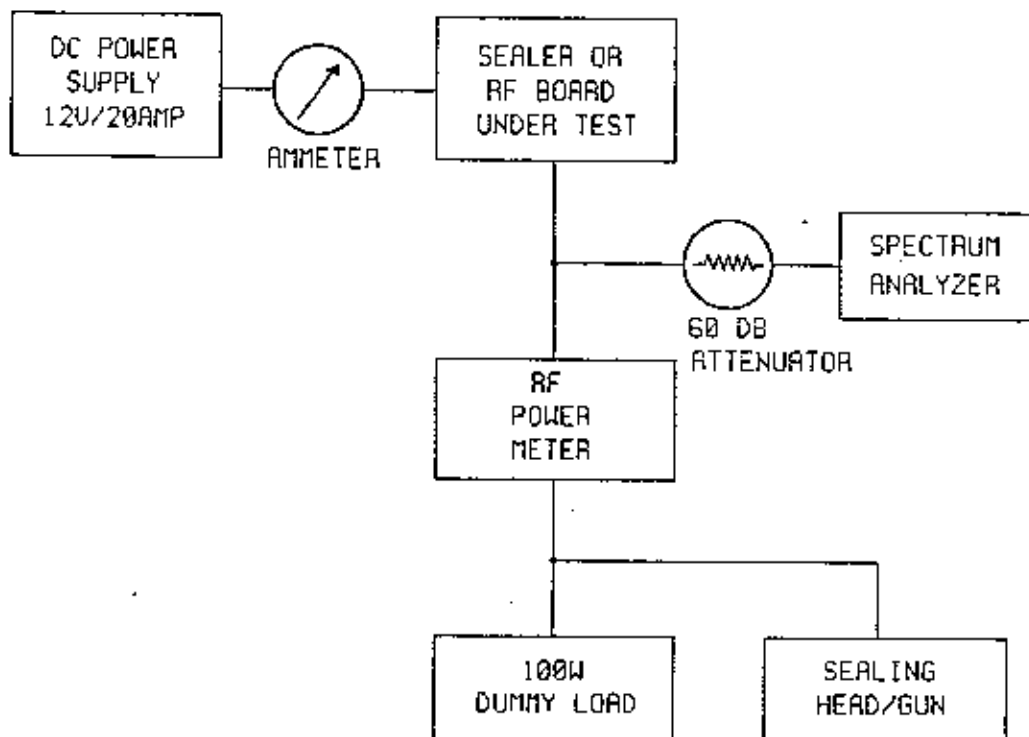

[Figure 5-3] RF Test Set-up

- (1) Set up test equipment according to the [Figure 5-3].
- (2) Set DC power supply at 12 volts.
Be sure to set a current-limit of the power supply at 20 amperes.

* CAUTION *
Failure to set current-limiter may cause RF transistors blown-up.
- (3) If following tests are to be done with RF board assembly taken out from its original location, prepare sufficient heat sinks and a cooling fan to avoid excess temperature rise at transistors and transformers on RF board.

*** CAUTION ***

Minimum heat dissipation gears to be prepared shall be 100 watts.
Failure to prepare sufficient heatsink for RF board assembly may cause the RF transistors blown-up.

- (4) Set RF power meter, attenuator and spectrum analyzer at proper ranges to check 40.68 MHz power of 150 watts maximum.
- (5) Turn on sealer power switch.
- (6) Every time when you need to measure any characteristics of RF circuit from following paragraph (7), push trigger lever at sealing-head or make short-circuit at control board between P2-pin4 and ground to trigger RF generation.

*** CAUTION ***

NEVER supply continuous power for more than ten seconds unless sufficient heatsink is prepared.

- (7) Watch power meter and spectrum analyzer. You should have more than 90 watts when a 50-ohm dummy load is connected at 40.68 MHz.
If you would have no oscillation, turn transformer T1 slowly until oscillation starts. Set T1 at mid point of the adjustable ranges where you have oscillation.
- (8) Read power meter.
Be sure to read effective power when a sealing gun unit is connected as RF load. Effective power is calculated as (forward power) - (reverse power).

*** NOTE 1 ***

Watch the ammeter to read supply current. Normal current will be less than 15A when a dummy load is connected. When a sealing-head is connected, maximum current could be as high as 18 amperes.

- (9) If RF board would not function properly, really there is not much thing to do. What you can do on the board is ;
 - a. Just examine the board by eyes to find any part is burnt or badly soldered.
 - b. Adjust transformer T1 as para. (7) above to get stable oscillation.
 - c. Touch to alter shapes of the coil L2 and L4 to change power level a little.
- (10) Turn powers off and disconnect test equipment.

5-7. Cleaning Sealing Head

Sealing head area and the trigger lever can easily be stained by dust, spilled or leaked blood or blood components. Frequent cleaning will offer users the best long-term results. Never put sharp objects or metal objects on sealing head electrodes, as they can easily be marred.

For proper cleaning, use a dry cloth or a cloth dampened with water. A mild detergent may be used. Do not use paint thinner, benzene, solvent or any strong detergent. Thoroughly dry sealing head area before applying power. If any sealing head is wet when RF energy is applied, an arc may appear.

Follow the decontamination procedure of your facility when a blood spill occurs. Avoid spraying liquids on the sealing heads. Refer to the procedures below:

- (1) Turn off the power switch.
- (2) Remove the protector screws and the head protectors.
- (3) Clean sealing heads and trigger levers carefully as described above.
- (4) Dry sealing heads thoroughly.
- (5) Reassemble the protectors and protector screws.
- (6) If you have used water, detergent or decontamination liquid, wait for a few minutes to allow for thorough drying.
- (7) Turn on the power switch and test the machine.

6. Schematic Diagram

- [Figure 6-1] System wiring diagram
- [Figure 6-2] Control board schematic diagram
- [Figure 6-3] I/O board schematic diagram
- [Figure 6-4] RF board schematic diagram
- [Figure 6-5] Filter board schematic diagram
- [Figure 6-6] Power distribution board schematic diagram
- [Figure 6-7] Distribution board schematic diagram
- [Figure 6-8] Switch board schematic diagram
- [Figure 6-9] Trigger board schematic diagram
- [Figure 6-10] Matching board schematic diagram

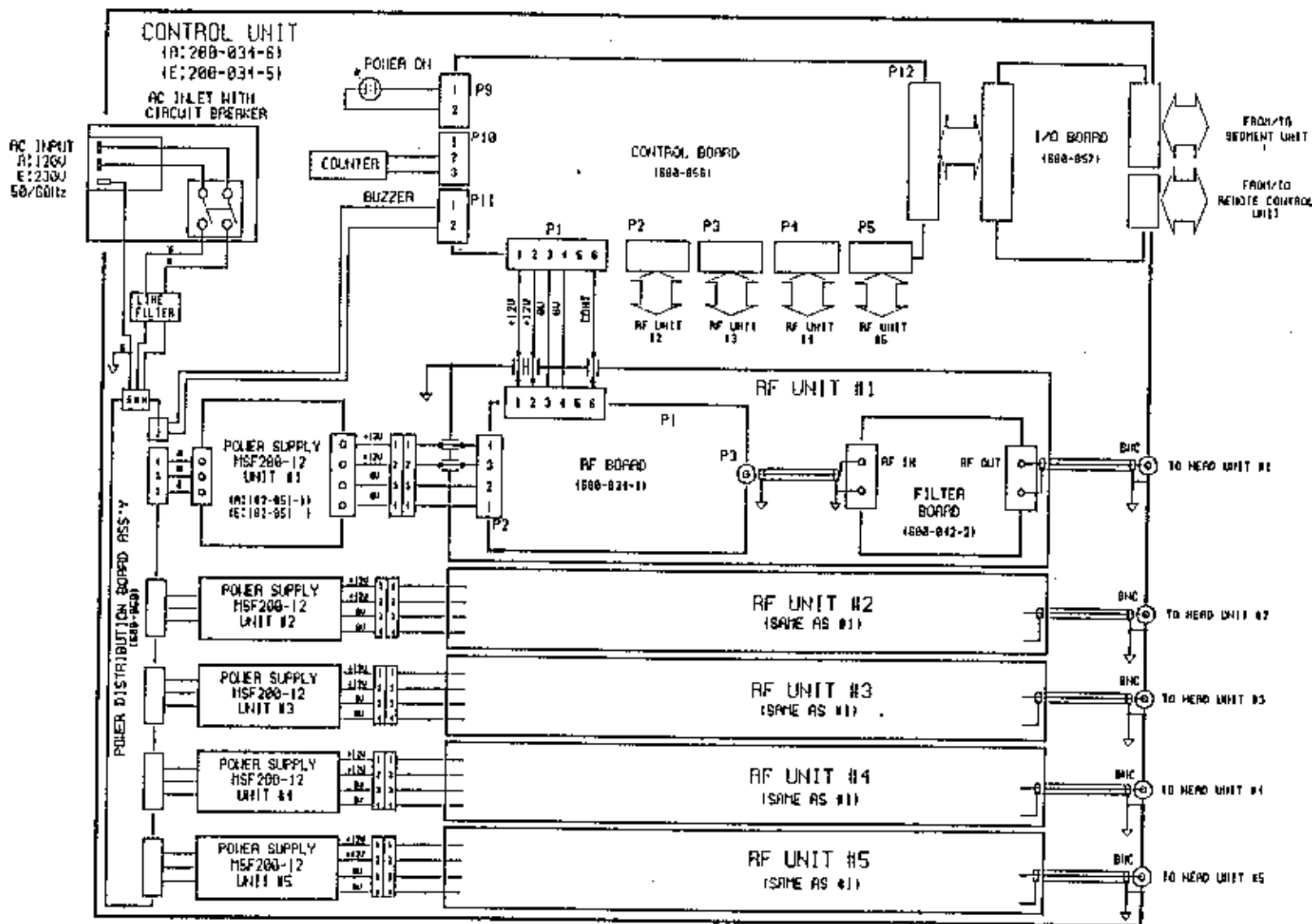

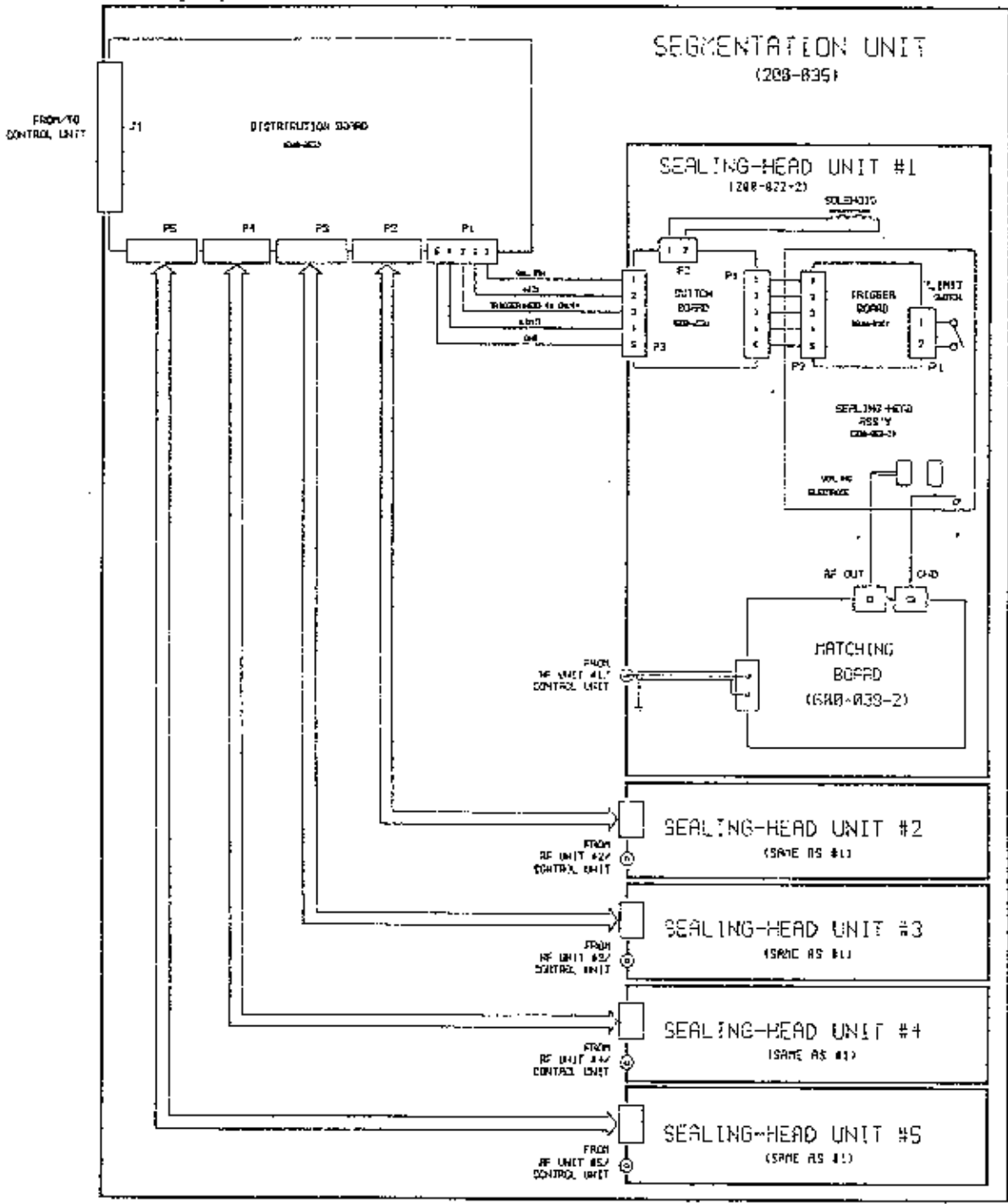

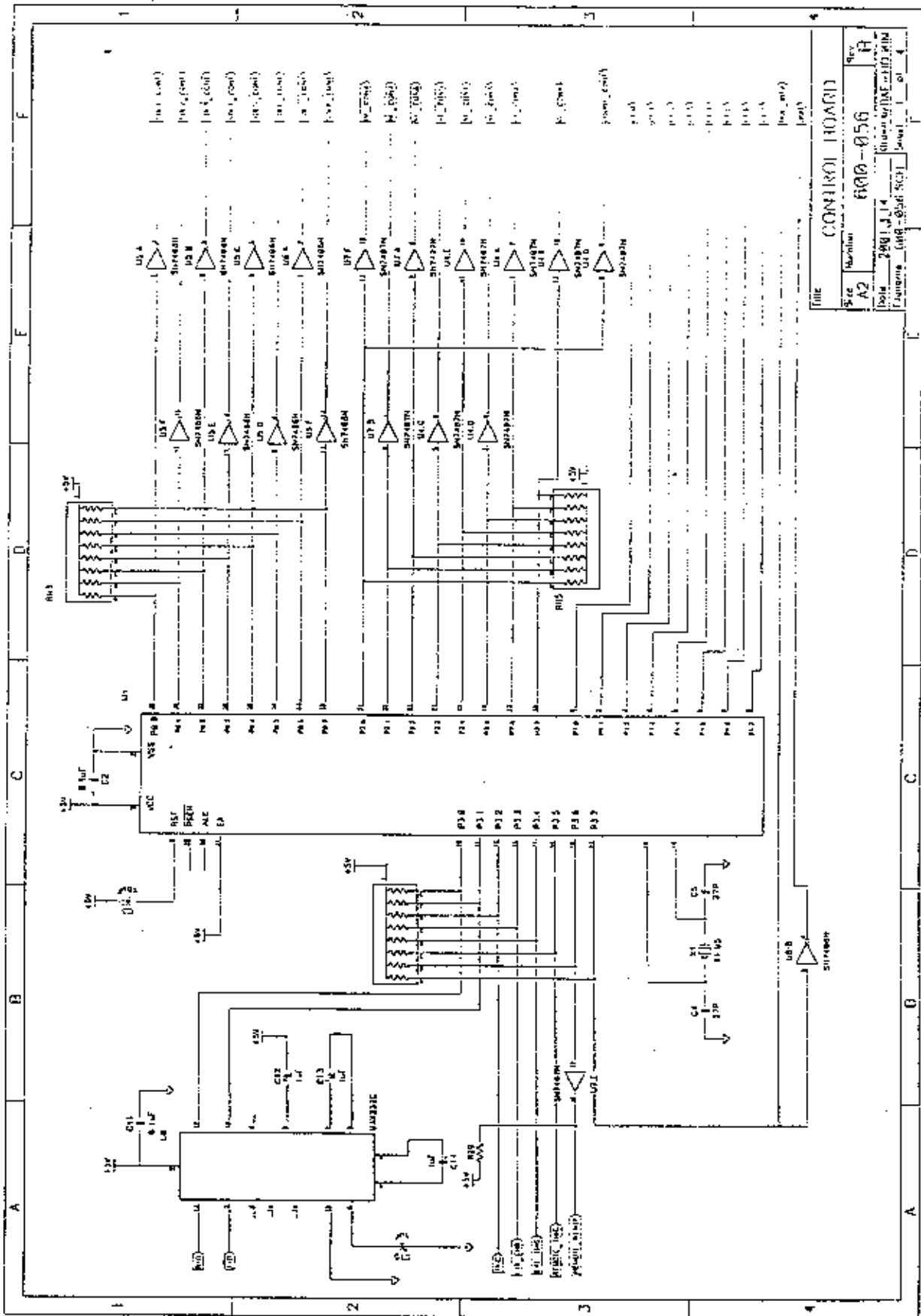

Title CONTROL BOARD			
Sec A2	Revision 600-056	Rev. R	
Doc. 2801.1.14	Drawn by DINE, J. H.	Checked by	
Frame 100-0001	Sheet 1	of 4	

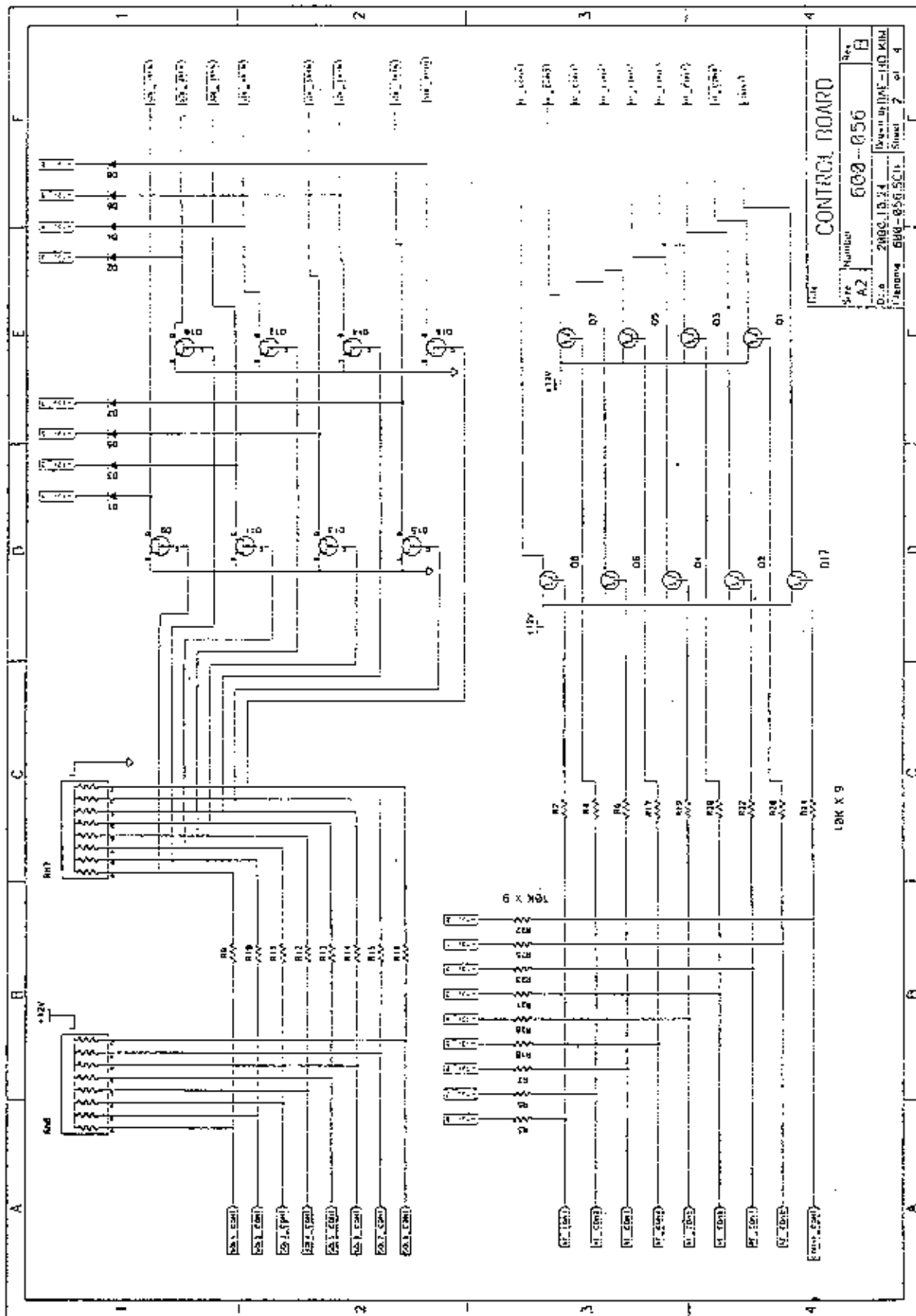

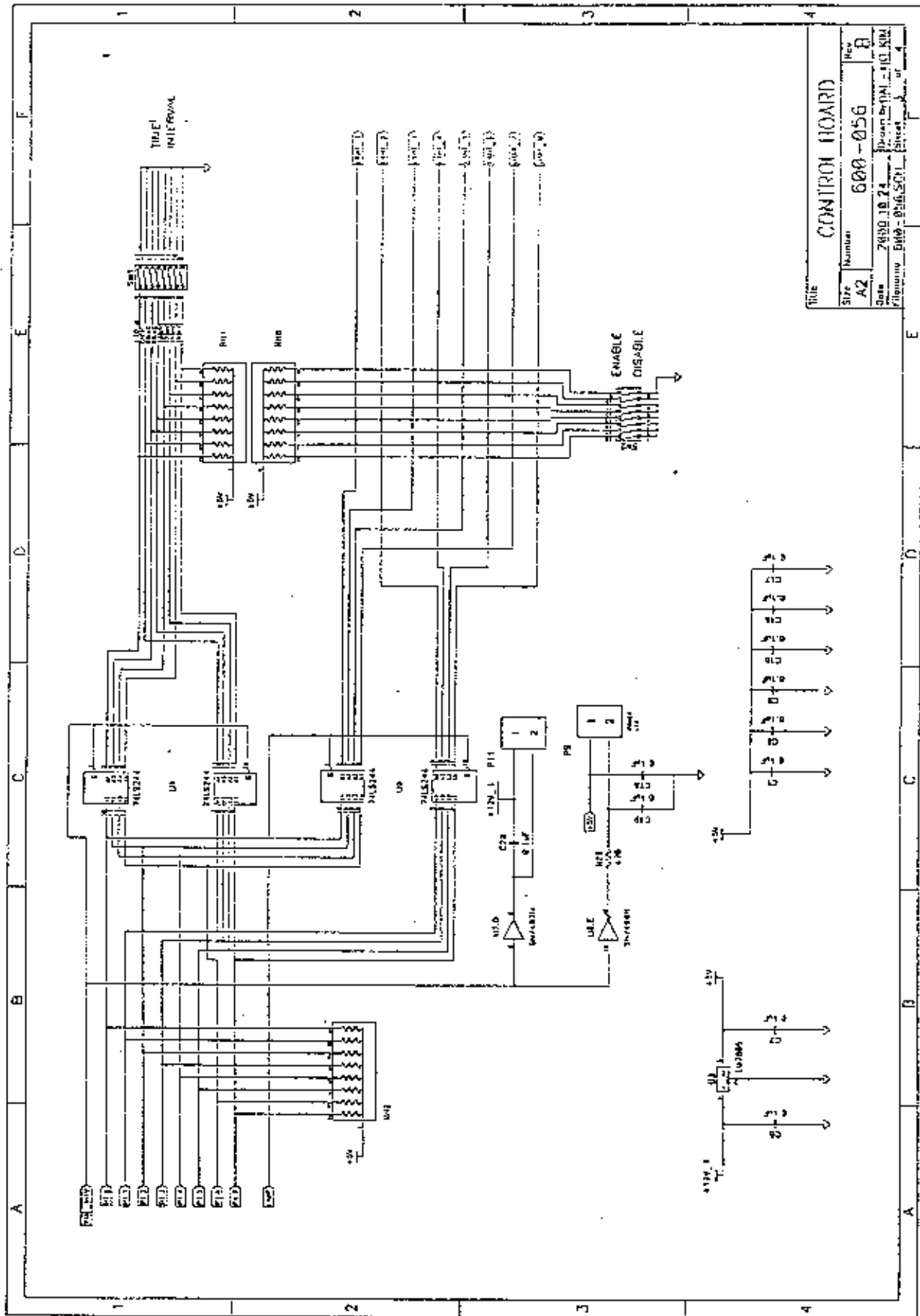

6-7

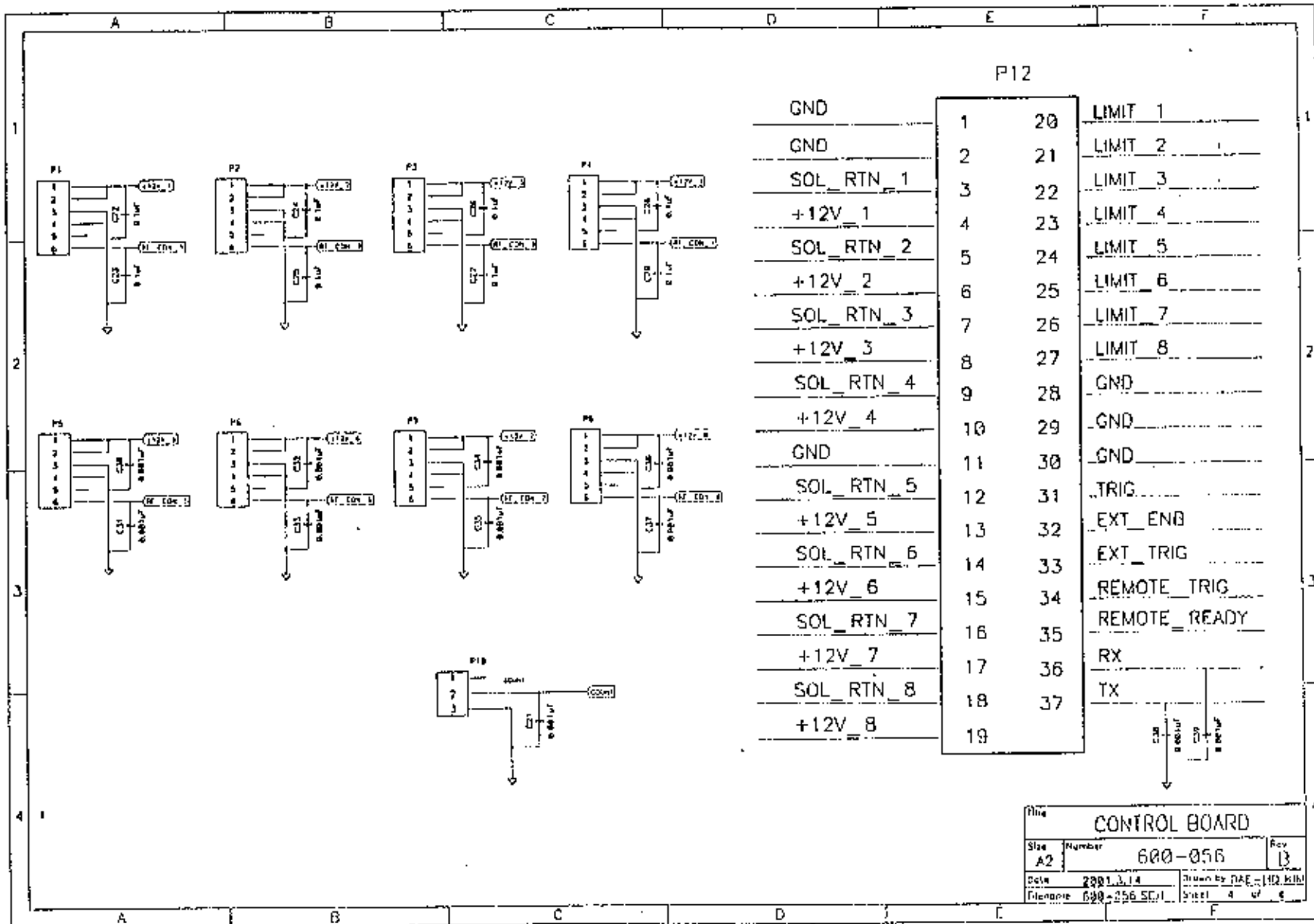

Title: CONTROL BOARD
 Size: A2
 Number: 600-056
 Rev: B
 Date: 2001.3.14
 Drawn by: DAE, JHJ, KIM
 File name: 600-056.SCH
 Sheet: 4 of 6

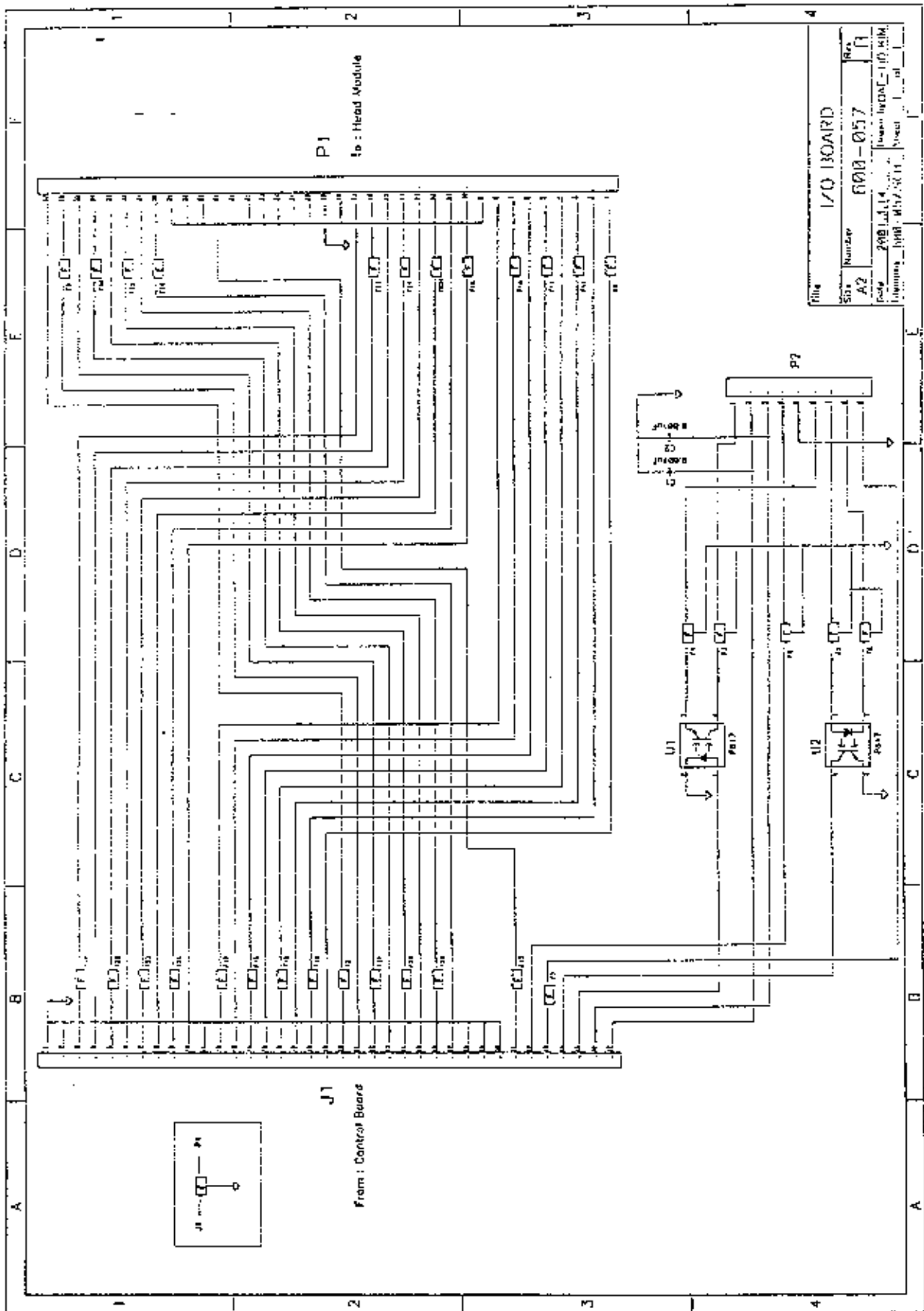

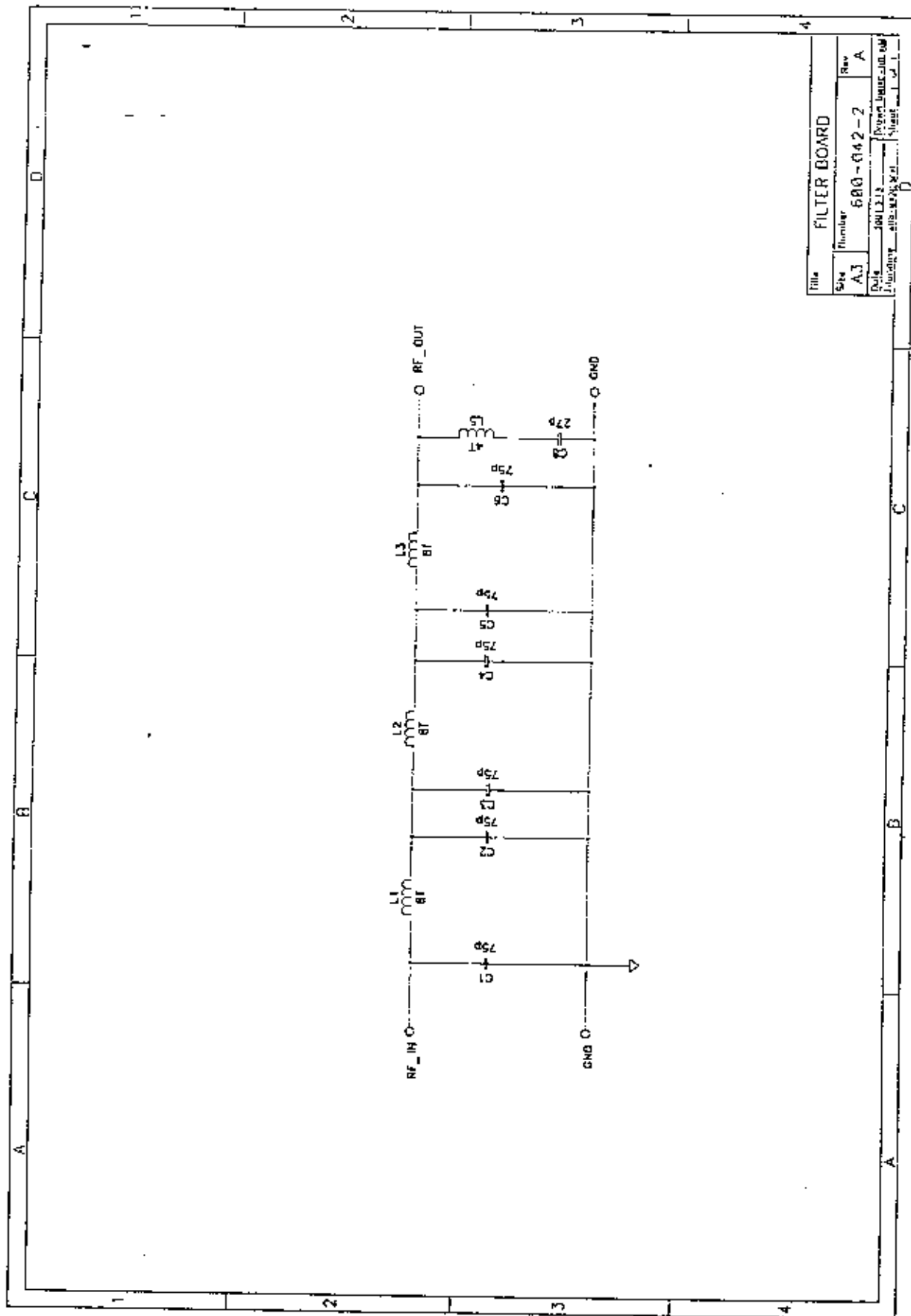

Title FILTER BOARD		
Size	Number	Rev
A3	680-042-2	A
Date	Drawn	Checked
10/13/12	efs. MJK/SAL	None
Quantity	Sheet	of
	1	1

11-9

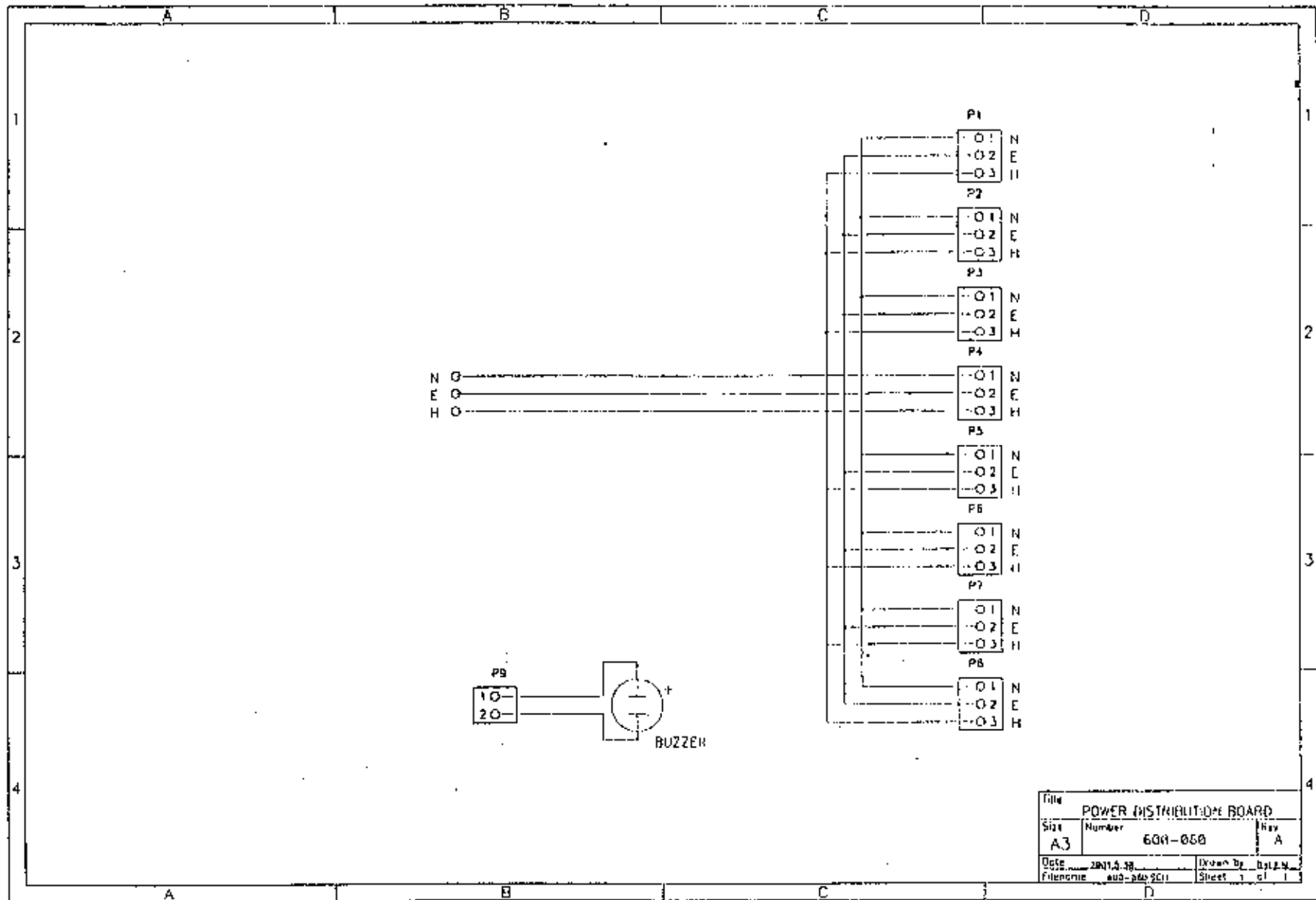

Title	POWER DISTRIBUTION BOARD	
Size	Number	Rev
A3	600-050	A
Date	2001.4.30	Drawn By
Filename	sub-200201	Sheet 1 of 1

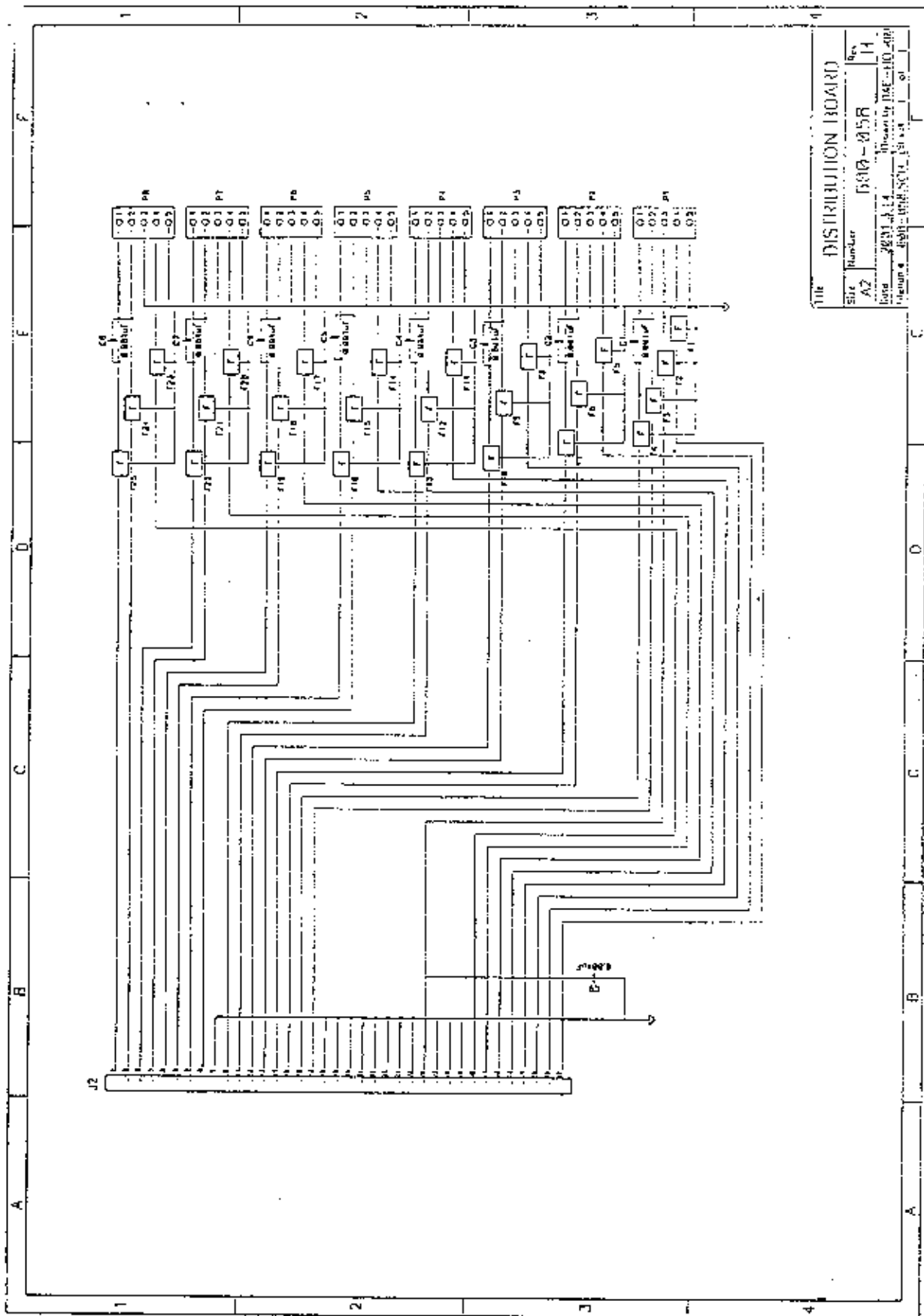

Title			
DISTRIBUTION BOARD			
Size	Number	Rev.	
A2	500-05R	14	
Drawn by JAC-110-200			
Checked by JAC-110-200			
Figure #	Sheet #	of	of
100-100-100	1	1	1

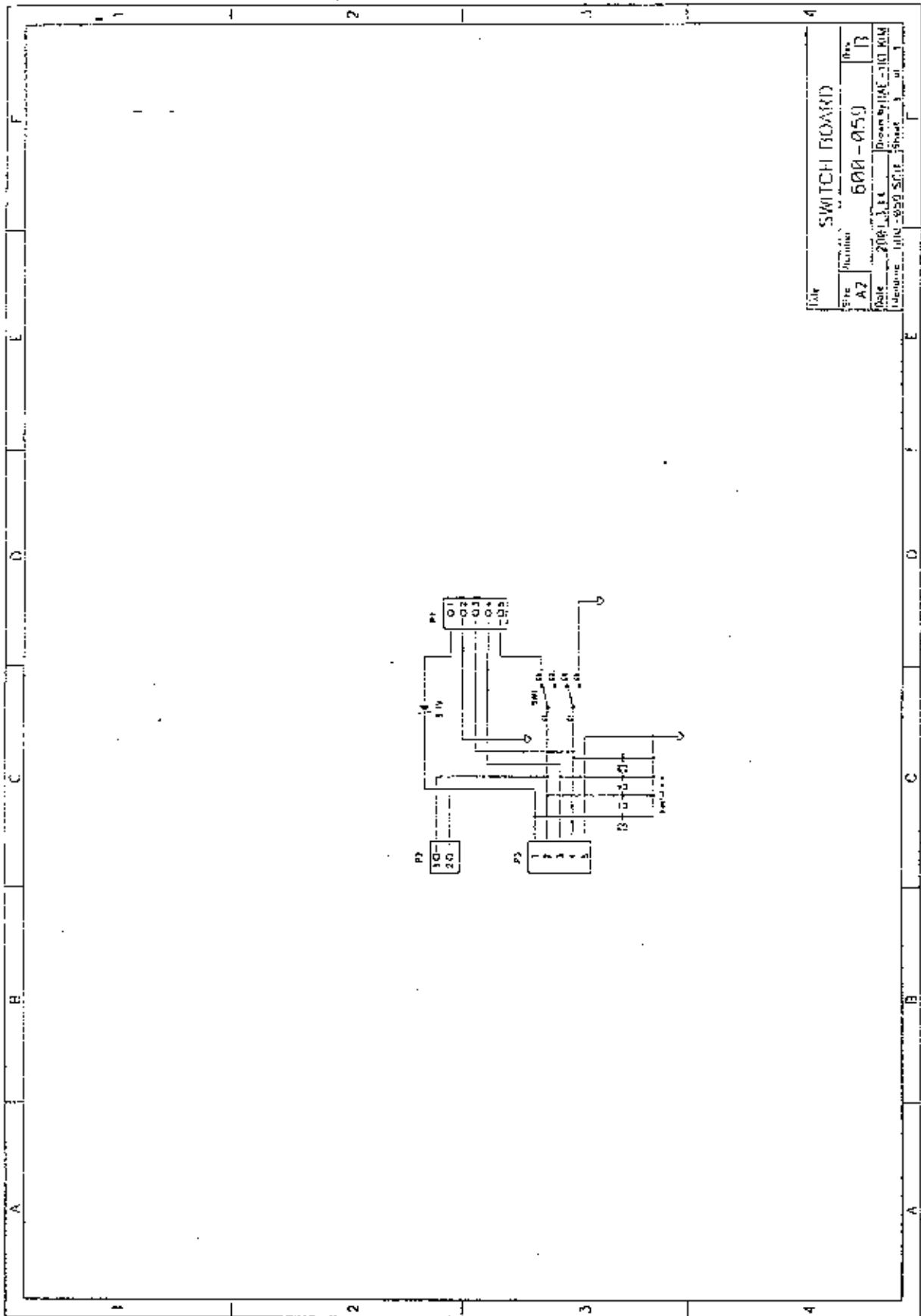

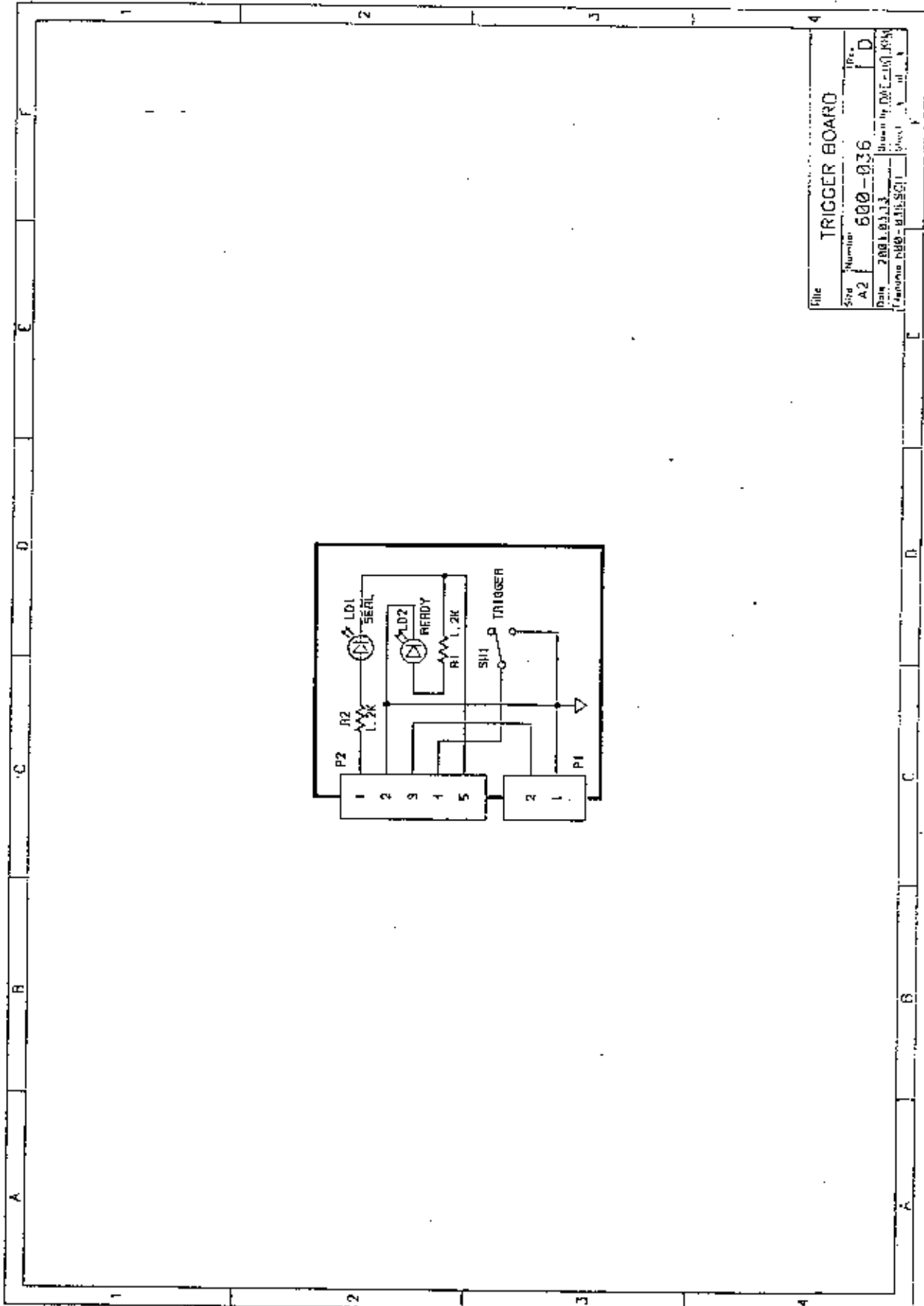

File		TRIGGER BOARD	
Size	Number	Price	
A2	600-036		D
Date	7001.03.13	Drawn by	DW (C-10) KMY
Quantity	100-010501	Sheet	1 of 1

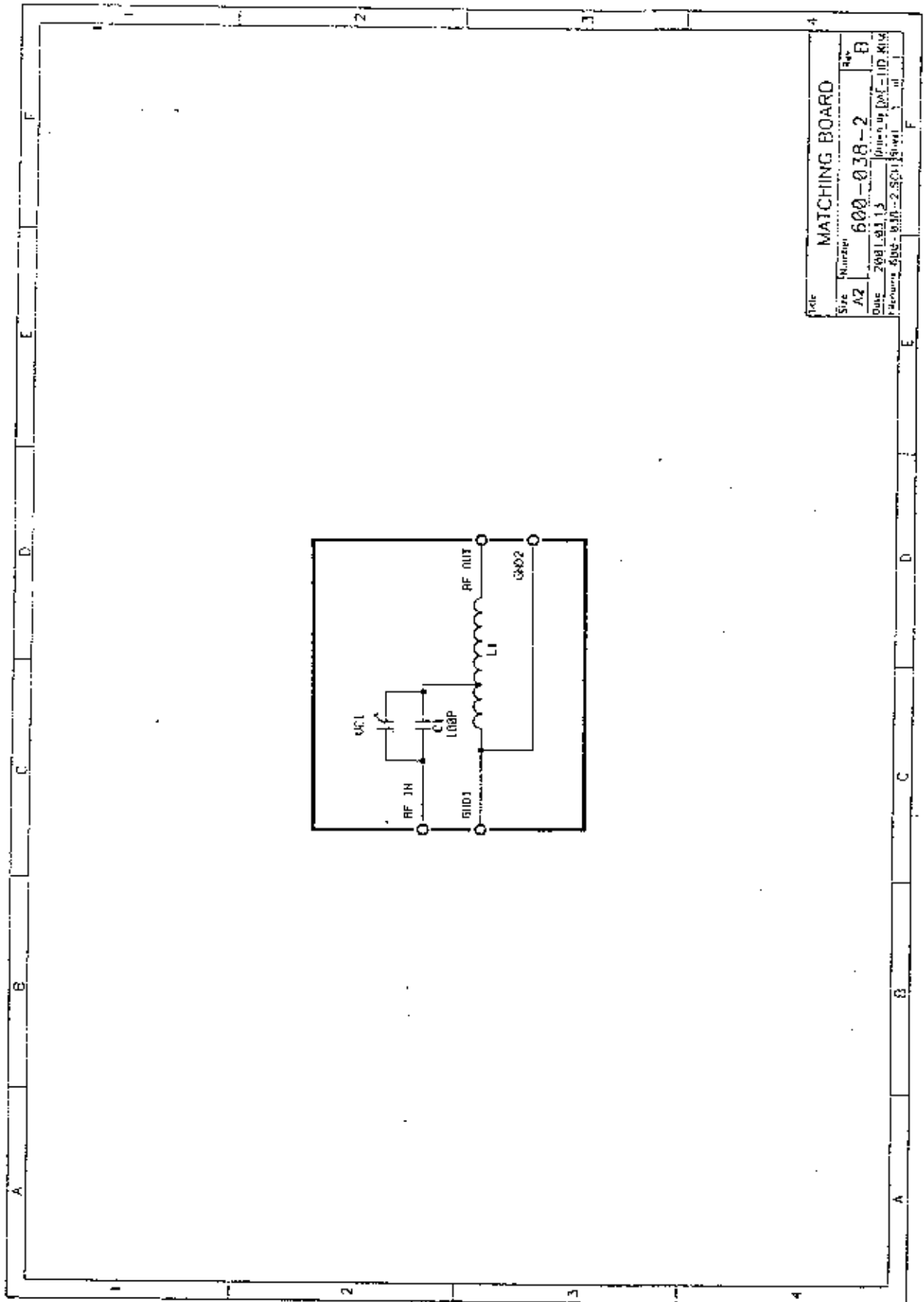

MATCHING BOARD			
Size	Number	Rev	
A2	600-038-2		B
Date	2001.03.13	Drawn by	[DF-10] K16
Checked	2001.03.13	Checked by	[DF-10] K16

7. Technical Illustration

- [Figure 7-1] Exploded view of MS950
 - . Control Unit (page 1/2)
 - . Segmentation Unit (page 2/2)
- [Figure 7-2] Control board layout
- [Figure 7-3] I/O board layout
- [Figure 7-4] RF board layout
- [Figure 7-5] Power distribution board layout
- [Figure 7-6] Distribution board layout
- [Figure 7-7] Trigger board layout
- [Figure 7-8] Matching board layout
- [Figure 7-9] Switch board layout
- [Figure 7-10] Filter board layout

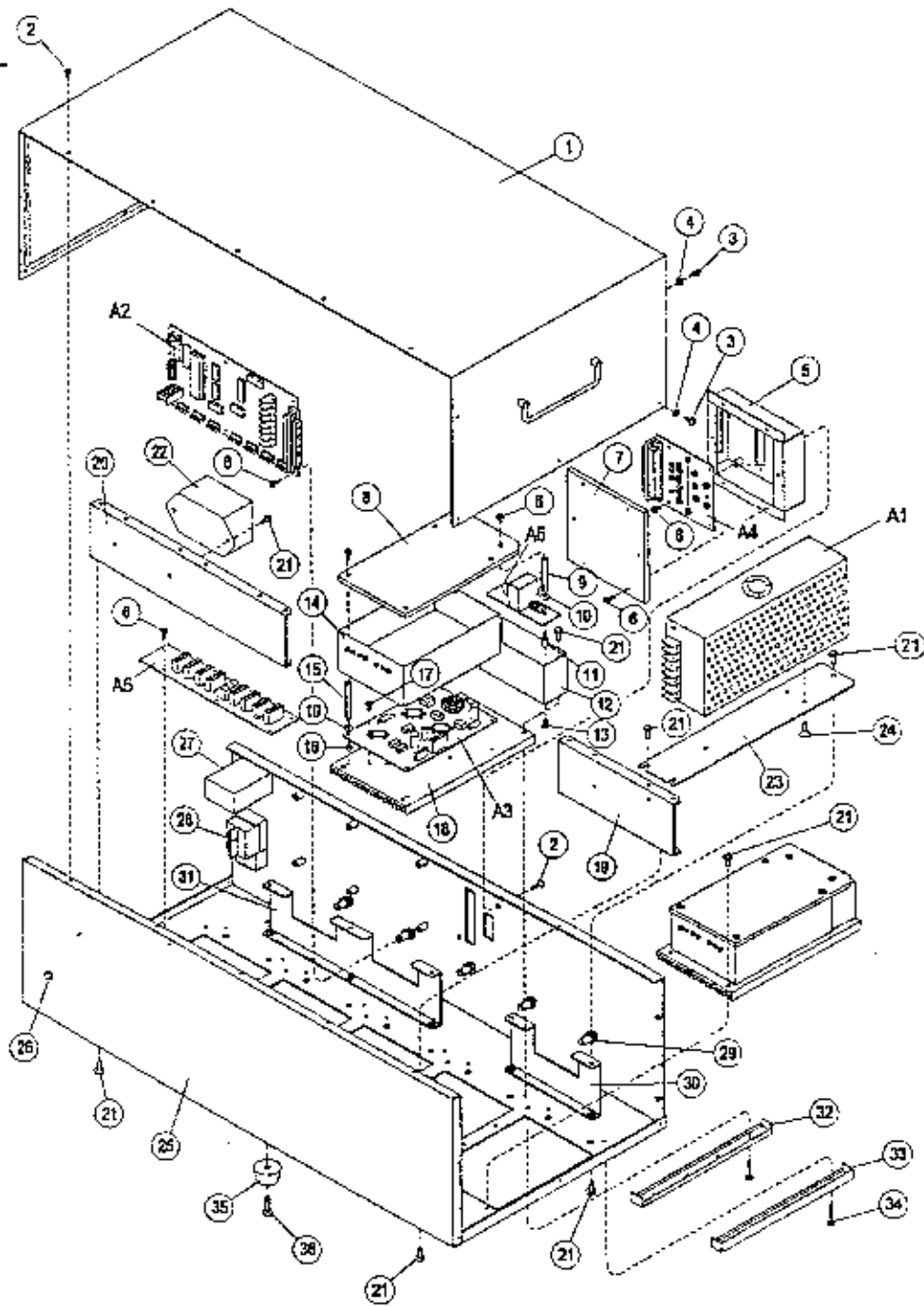

[Figure 7-1] Exploded View of MS950 (page 1/2, Control Unit)

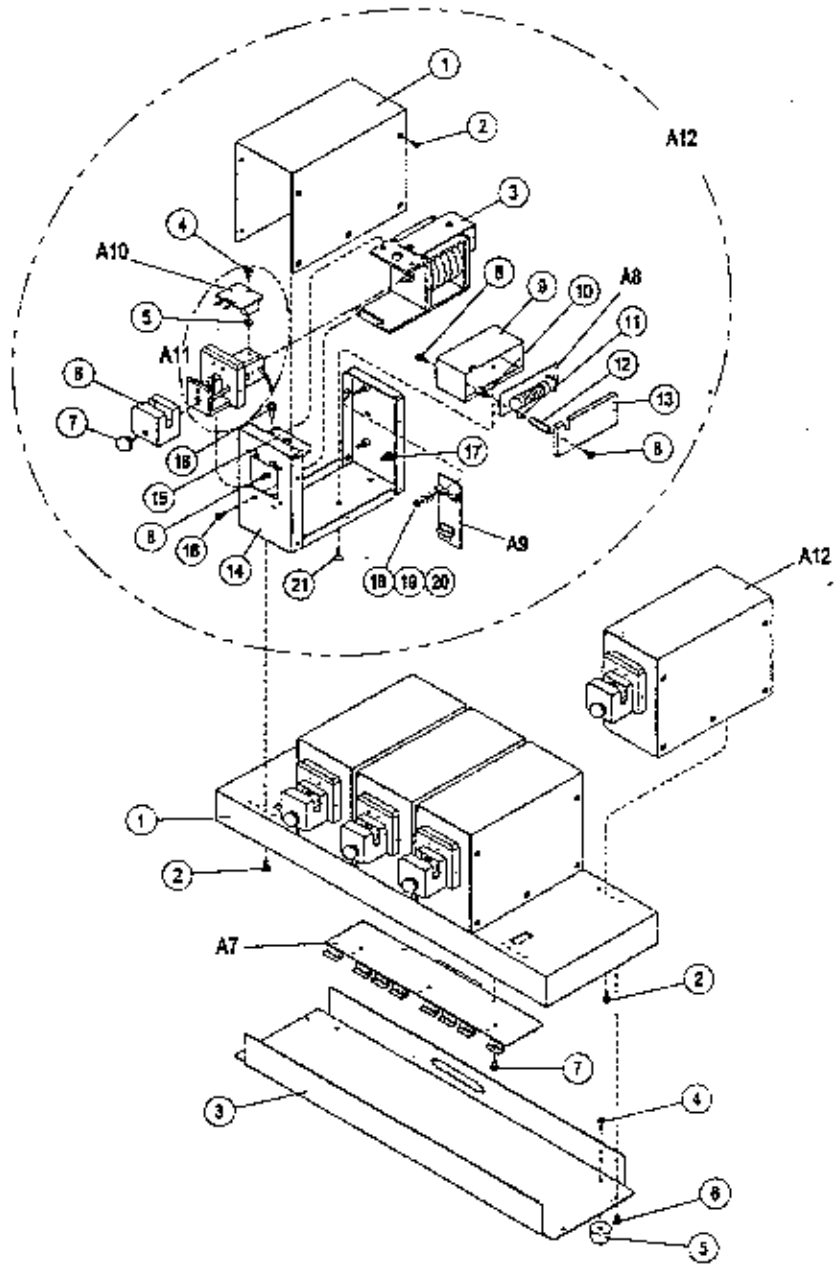

[Figure 7-1] Exploded View of MS950 (page 2/2, Segmentation Unit)

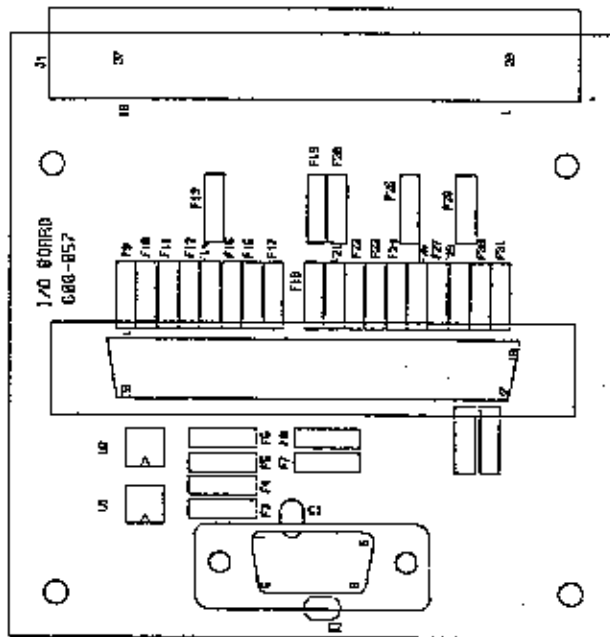

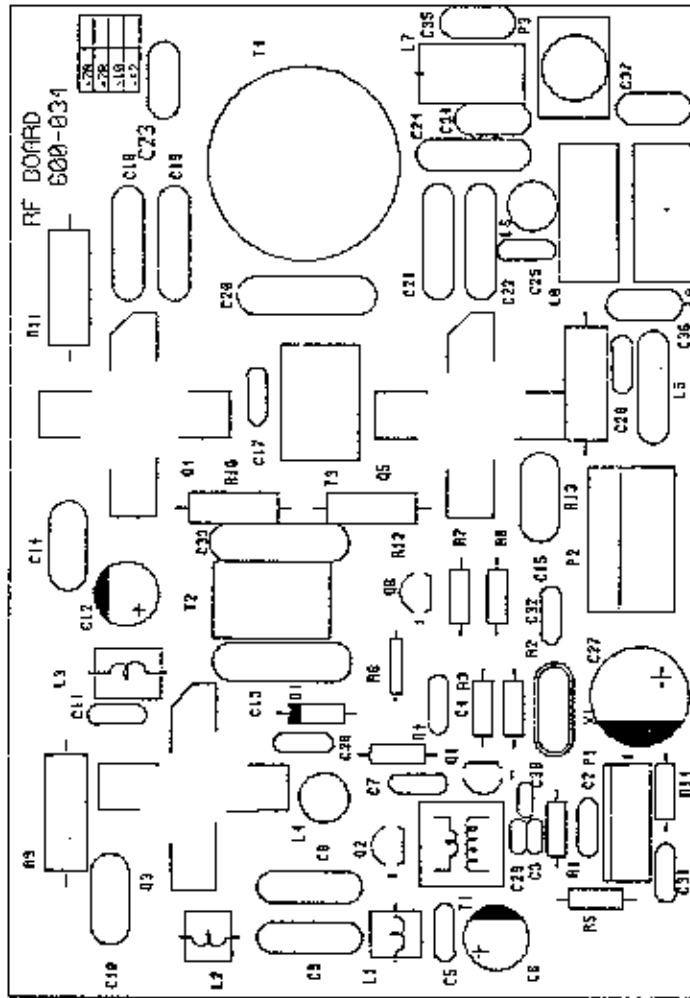

7-7

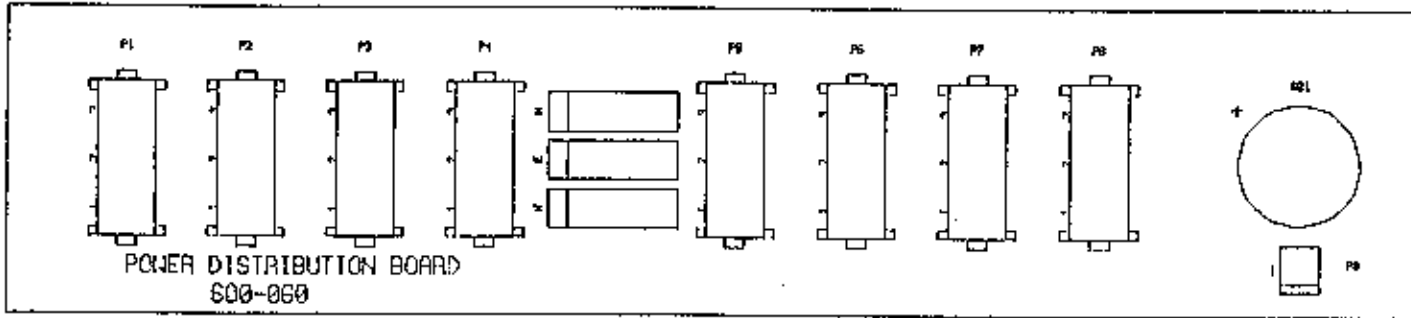

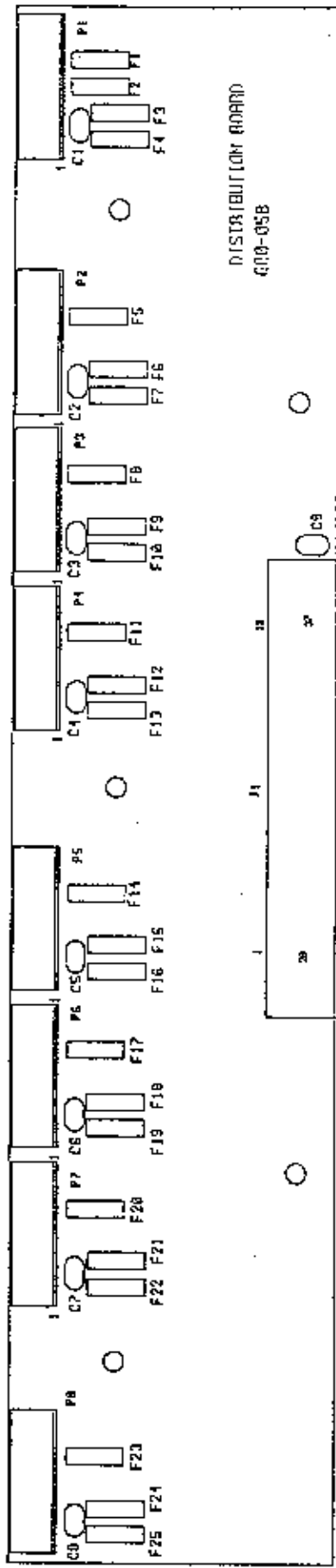

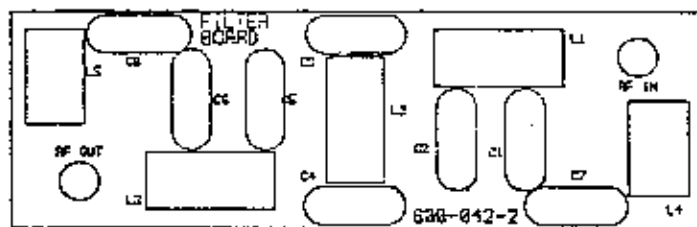
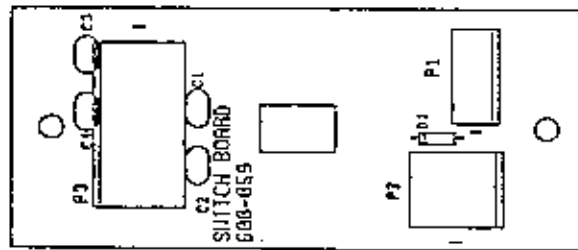
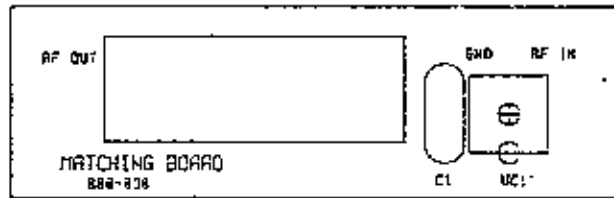
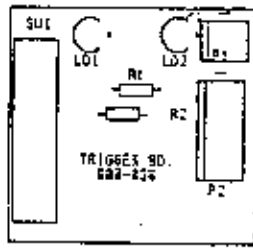

8. Part List

Each part is identified with manufacturer's part number in the Part List.

Part location in unit is found by the find number in exploded views and circuit board layouts in Chapter 7. Prefix 'A' in find number denotes that it is not a single component but an assembly, so a lower-level part list of which is presented at another place.

Order for servicing parts to distributor or manufacturer should accompany part numbers.

PART LIST OF SEGMENTATION SYSTEM MS930A/E - MS970A/E

SEGMENTATION SYSTEM (PART NO. : NOTE 1 - A)													
FIND NO.	DESCRIPTION	PART NO.	List	MS930A	MS930E	MS940A	MS940E	MS950A	MS950E	MS960A	MS960E	MS970A	MS970E
	CONTROL UNIT	(NOTE 1 - B)	0	1	1	1	1	1	1	1	1	1	1
	SEGMENTATION UNIT	(NOTE 1 - C)	0	1	1	1	1	1	1	1	1	1	1
	DATA CABLE	700-028		1	1	1	1	1	1	1	1	1	1
	RF CABLE, RG58-BNC	WHS-015		3	3	4	4	5	5	6	6	7	7
	POWER CORD, SJP-1, 110V	603-009		1				1		1			
	POWER CORD, SJP-516A, 220V	603-011			1		1				1		

CONTROL UNIT (PART NO. : NOTE 1 - B)													
FIND NO.	DESCRIPTION	PART NO.	List	MS930A	MS930E	MS940A	MS940E	MS950A	MS950E	MS960A	MS960E	MS970A	MS970E
1	UPPER COVER	(NOTE 2 - A)		1	1	1	1	1	1	1	1	1	1
2	SCREW	MCC03-08S		5	5	6	6	7	7	8	8	8	8
3	SCREW	MTC03-08S		15	15	16	16	17	17	18	18	18	18
4	WASHER, STAR	WSS03-00S		15	15	16	16	17	17	18	18	18	18
5	I/O BOARD CASE	401-212		1	1	1	1	1	1	1	1	1	1
6	SCREW	MPC03A08L		28	28	28	28	28	28	28	28	28	28
7	I/O SHIELD COVER	401-213		1	1	1	1	1	1	1	1	1	1
8	SHIELD COVER	401-218		3	3	4	4	5	5	6	6	7	7
9	STANDOFF M3x30 THRU	101-035		6	6	8	8	10	10	12	12	14	14
10	WASHER, PL.	W/PL03-001		18	18	24	24	30	30	36	36	42	42
11	STANDOFF M3x15 STUD	101-014		6	6	8	8	10	10	12	12	14	14
12	FILTER BOARD BOX	401-219		3	3	4	4	5	5	6	6	7	7
13	SCREW	MTC03-06S		6	6	8	8	10	10	12	12	14	14
14	SHIELD CASE	401-217		3	3	4	4	5	5	6	6	7	7
15	STANDOFF, M3x45x12	302-127		12	12	16	16	20	20	24	24	28	28
16	NUT	NIJ004-RF		12	12	16	16	20	20	24	24	28	28
17	SCREW	MPC03A10S		18	18	24	24	30	30	36	36	42	42
18	RF HEATSINK	304-006		3	3	4	4	5	5	6	6	7	7
19	SMPS SUPPORT, F2	401-239				2	2	1	1			2	2
20	SMPS SUPPORT, F3	401-239-1		1	1			1	1	2	2	1	1
21	SCREW	MPC04A10F		29	29	38	38	47	47	56	56	65	65
22	LINE FILTER, BS1-F10	FTR-008		1	1	1	1	1	1	1	1	1	1
23	PLATE, SMPS	401-238		3	3	4	4	5	5	6	6	7	7
24	SCREW	MCC04-08S		9	9	12	12	15	15	18	18	21	21
25	BOTTOM CASE	(NOTE 2 - B)		1	1	1	1	1	1	1	1	1	1
26	LED, DI-1HS2GN1 GRN D=3MM	LED-002		1	1	1	1	1	1	1	1	1	1
27	COUNTERR	102-050		1	1	1	1	1	1	1	1	1	1
28	POWER ENTRY MODULE, 7764X9999A425AD, 4A	FTR-009-1			1		1						
28	POWER ENTRY MODULE, 7764X9999A425BD, 6A	FTR-009-2		1					1		1		

28	POWER ENTRY MODULE, 7764X9999A425CD, 8A	FTR-009-3					1						1
28	POWER ENTRY MODULE, 7764X9999A425DD, 10A	FTR-009-4						1					
28	POWER ENTRY MODULE, 7764X9999A425ED, 15A	FTR-009-5								1		1	
29	CONNECTOR, BNC-BA	CON-126		3	3	4	4	5	5	6	6	7	7
30	SMPS SUPPORT, R2	401-240				2	2	1	1			2	2
31	SMPS SUPPORT, R3	401-241		1	1			1	1	2	2	1	1
32	HEATSINK M/T BRACKET, A	401-234		2	2	3	3	4	4	5	5	6	6
33	HEATSINK M/T BRACKET, D	401-235		2	2	2	2	2	2	2	2	2	2
34	SCREW	MPC03A201		16	16	20	20	24	24	28	28	32	32
35	RUBBER FOOT	101-039		4	4	4	4	4	4	6	6	6	6
36	SCREW	MPC01A181		4	4	4	4	4	4	6	6	6	6
A1	POWER SUPPLY UNIT, MSF200-12, 110V	102-051-1		3		4		5		6		7	
A1	POWER SUPPLY UNIT, MSF200-12, 220V	102-051			3		4		5		6		7
A2	CONTROL BOARD ASSEMBLY	600-056	O	1	1	1	1	1	1	1	1	1	1
A3	RF BOARD ASSEMBLY	600-034-1A	O	3	3	4	4	5	5	6	6	7	7
A4	V/D BOARD ASSEMBLY	600-057	O	1	1	1	1	1	1	1	1	1	1
A5	POWER DISTRIBUTION BOARD ASSEMBLY	600-060	O	1	1	1	1	1	1	1	1	1	1
A6	FILTER BOARD ASSEMBLY	600-042-2	O	3	3	4	4	5	5	6	6	7	7

SEGMENTATION UNIT (PART NO. : NOTE 1 - C)													
FIND NO.	DESCRIPTION	PART NO.	Lib	MS930A	MS930E	MS940A	MS940E	MS950A	MS950E	MS960A	MS960E	MS970A	MS970E
1	BOTTOM CASE, 2	(NOTE 2 - C)		1	1	1	1	1	1	1	1	1	1
2	SCREW	MPC03A101		6	6	8	8	10	10	12	12	14	14
3	BOTTOM COVER, 2	(NOTE 2 - D)		1	1	1	1	1	1	1	1	1	1
4	SCREW	MPC03A121		4	4	4	4	4	4	4	4	4	4
5	RUBBER FOOT	101-008		4	4	4	4	4	4	4	4	4	4
6	SCREW	MTC03-06S		4	4	4	4	4	4	4	4	4	4
7	SCREW	MPC01A081		5	5	5	5	5	5	5	5	5	5
A7	DISTRIBUTION BOARD ASSEMBLY	600-058	O	1	1	1	1	1	1	1	1	1	1
A12	SEALING HEAD UNIT	200-022-2	O	3	3	4	4	5	5	6	6	7	7

NOTE 1 : PART NUMBER OF SYSTEM AND UNIT OF EACH MODEL

	DESCRIPTION	MS930A	MS930E	MS940A	MS940E	MS950A	MS950E	MS960A	MS960E	MS970A	MS970E
1 - A	SEGMENTATION SYSTEM	100-024-2	100-024-1	100-024-4	100-024-3	100-024-6	100-024-5	100-024-8	100-024-7	100-024-10	100-024-9
1 - B	CONTROL UNIT	200-034-2	200-034-1	200-034-4	200-034-3	200-034-6	200-034-5	200-034-8	200-034-7	200-034-10	200-034-9
1 - C	SEGMENTATION UNIT	200-035-1	200-035-1	200-035-2	200-035-2	200-035-3	200-035-3	200-035-4	200-035-4	200-035-5	200-035-5

NOTE 2 : PART NUMBER OF MODEL-SPECIFIC PARTS

	DESCRIPTION	MS930A	MS930E	MS940A	MS940E	MS950A	MS950E	MS960A	MS960E	MS970A	MS970E
2 - A	UPPER COVER	401-211-3	401-211-3	401-211-1	401-211-1	401-211	401-211	401-211-2	401-211-2	401-211-4	401-211-4
2 - B	BOTTOM CASE	401-210-3	401-210-3	401-210-1	401-210-1	401-210	401-210	401-210-2	401-210-2	401-210-4	401-210-4
2 - C	BOTTOM CASE, 2	401-214-3	401-214-3	401-214-1	401-214-1	401-214	401-214	401-214-2	401-214-2	401-214-4	401-214-4
2 - D	BOTTOM COVER, 2	401-215-3	401-215-3	401-215-1	401-215-1	401-215	401-215	401-215-2	401-215-2	401-215-4	401-215-4

A2, CONTROL BOARD ASSEMBLY (PART NO. : 600-056)				
FIND NO.	DESCRIPTION	PART NO.	List	QTY
	PCB, CONTROL BOARD	601-056		1
U1, U9	IC, CD741ICT244	ICT-244-ICT		2
U2	IC, AT89C51	ICS-008		1
U3	IC, QL7805	ICR-003		1
U4, U7	IC, TTL 7407	ICT-007		2
U5, U6	IC, TTL 7406	ICT-006		2
U8	IC, MAX232C	ICS-007		1
R2-R9	RES. CF 10K-01M 1/4W 5%	RDOB103J		8
R10-R17	RES. CF 4.7K-01M 1/4W 5%	RDOB422J		8
R18-R25	RES. CF 10K-01M 1/4W 5%	RDOB103J		8
R26	RES. CF 470-01M 1/4W 5%	RDOB471J		1
R27, R28	RES. CF 10K-01M 1/4W 5%	RDOB103J		2
R29	RES. CF 470-01M 1/4W 5%	RDOB471J		1
R30	RES. CF 10K-01M 1/4W 5%	RDOB103J		1
C1, C2	CAP. DISK CER, 0.1uF 25V 20%	CK1EL104Z		2
C3	CAP. ELEC 10uF 25V 20% SM TYPE	CE1EL106R		1
C4, C5	CAP. DISK CER, 27pF 25V 20%	CK1EL270Z		2
C6-C11	CAP. DISK CER, 0.1uF 25V 20%	CK1EL104Z		6
C12-C15	CAP. ELEC, 10uF 25V SM TYPE	CE1EL106R		4
C16, C17	CAP. DISK CER, 0.1uF 25V 20%	CK1EL104Z		2
C18-C39	CAP. DISK CER, 1000pF 25V 20%	CK1EL102Z		22
C40	CAP. DISK CER, 0.1uF 25V 20%	CK1EL104Z		1
RN1-RN6	RESISTOR ARRAY, 10K 01M 9PIN	RNW-005		6
RN7	RESISTOR ARRAY, 1M 01M 9PIN	RNW-004		1
RN8	RESISTOR ARRAY, 10K 01M 9PIN	RNW-005		1
Q1-Q8	TR, 2N2907A	QTR-017		8
Q9-Q16	FET, BUZ11A	FEF-001		8
Q17	TR, 2N2907A	QTR-017		1
D1-D8	DIODE, 1N4007	DCR-003		8
D9	DIODE, 1N4148	DCR-001		1
SW1, SW 2	SWITCH, 16 - 13p, KS10081	SWI-017		2
P1-P8	CONNECTOR, W.5045-06A MOLEX	CON-004		8
P9	CONNECTOR, W.5045-02A MOLEX	CON-018		1
P10	CONNECTOR, W.5045-03A MOLEX	CON-001		1
P11	CONNECTOR, 37-D SUB RIGHT FEMALE	CON-129		1
P12	CONNECTOR, W.5267-02A MOLEX	CON-029		1
X1	CRYSTAL, HC-18 / U, 11.0592MHz	XFI-003		1
	IC SOCKET, 40 PIN	SCK-006		1

A4, I/O BOARD ASSEMBLY (PART NO. : 600-057)				
FIND NO.	DESCRIPTION	PART NO.	List	QTY
	PCB, I/O BOARD	601-057		1
J1	CON, 37-D SUB RIGHT ANGLE MALE	CON-132		1
P1	CON, 37-D SUB STRAIGHT FEMALE	CON-131		1
P2	CON, 9-D SUB STRAIGHT FEMALE	CON-130		1
U1, U2	PHOTO TRIANISISTOR, PC817	ICL-012		2
C1, C2	CAP. DISK CER, 1000pF 25V 20%	CK1EL102Z		2
F1-F31	3-TERMINAL EMI FILTER, EFS104YD	FFR-005		31

A5, POWER DISTRIBUTION BOARD ASSEMBLY (PART NO. : 600-060)				
FIND NO.	DESCRIPTION	PART NO.	List	QTY
	PCB, POWER DISTRIBUTION BOARD	601-060		1
P1-P8	CONNECTOR, 42002-03, MALE, MOLEX	CON-133		8
P9	CON, W, 5267-02A	CON-029		1
BZ1	BUZZER, TMB-12, DC 12V	BZ2-002		1
N, R, H	TERMINAL BLOCK, AK3001	TER-019		3

A6, FILTER BOARD ASSEMBLY (PART NO. : 600-042-2)				
FIND NO.	DESCRIPTION	PART NO.	List	QTY
	PCB, FILTER BOARD	601-042-2		1
C1-C6	CAP. MICA, DM15F750J5	CM3CL750J		6
C8	CAP. MICA, DM15E270J5	CM3CL270J		1
L1-L3	COIL, SN 1.0mm, D=5.5mm, T=8	IND-019		3
L5	COIL, SN 1.0mm, D=5.5mm, T=4	IND-015		1
RF IN	WIRING HARNESS ASS'Y, RF-IN	WIIS-124		1
RF OUT	WIRING HARNESS ASS'Y, RF-OUT	WIIS-125		1
	FILTER COVER A	401-232		1
	FILTER COVER B	401-233		1

A7, DISTRIBUTION BOARD ASSEMBLY (PART NO. : 600-058)				
FIND NO.	DESCRIPTION	PART NO.	List	QTY
	PCB, DISTRIBUTION BOARD	601-058		1
J1	CON, 37-D SUB RIGHT ANGLE MALE	CON-132		1
C1-C9	CAP. DISK CER, 1000pF 25V 20%	CK1EL102Z		9
F1-F25	3-TERMINAL EMI FILTER, EFS104YD	FFR-005		25
P1-P8	CONNECTOR, W.5274-05A MOLEX	CON-015		8

A1. RF BOARD ASSEMBLY (PART NO. : 600-034-1A)			
FINO NO.	DESCRIPTION	PART NO.	QTY
	PCB, RF BOARD	601-034	1
Q1	TR, MPFH 40KSP10	QTR-019	1
Q2	TR, 2SC1066 KRC	QTR-020	1
Q3	TR, JIF20-12	QTR-016	1
Q4, Q5	TR, 2SC2290	QTR-015	2
Q6	TR, 2SC2655	QTR-021	1
CRI	DIODE, IN4001	QCR-004	1
R1	RES. CF, 27K-OHM 1/4W 5%	RD00P27J	1
R2, R7	RES. CF, 47K-OHM 1/4W 5%	RD00P47J	2
R3	RES. CF, 180-OHM 1/4W 5%	RD00P18J	1
R4	RES. CF, 68-OHM 1/4W 5%	RD00P68J	1
R5	RES. CF, 10-OHM 1/4W 5%	RD00P10J	1
R6	RES. CF, 100-OHM 1/2W 5%	RD00P100J	1
R8	RES. CF, 10K-OHM 1/4W 5%	RD00P10KJ	1
R9	RES. MO, 200-OHM 2W 5%	RS02P20J	1
R10, R12	RES. MO, 10-OHM 1W 5%	RS01P10J	2
R11, R13	RES. MO, 100-OHM 2W 5%	RS02P100J	2
R14	RES. CF, 470-OHM 1/4W 5%	RD00P47J	1
C2, 5, 11, 17	CAP. DISK CER, 0.1uF 25V 20%	CK1EL104Z	4
C3	CAP. DISK CER, 27pF 25V 20%	CK1EL27Z	1
C4	CAP. DISK CER, 100pF 25V 20%	CK1EL10Z	1
C6	CAP. ELFC, 100uF 16V 20% SM	CE1CL10R	1
C7	CAP. DISK CER, 0.01uF 25V 20%	CK1EL103Z	1
C8, C9	CAP. STYRENE, 68pF 25V 20%	CS1EL68Z	2
C10, C15	CAP. MF, 0.1uF 400V 10%	CQ2GL104K	2
C12	CAP. ELFC, 47uF 16V 20% SM	CE1CL47R	1
C13	CAP. MICA, DM1512215	GM3CL22J	1
C14	CAP. MF, 0.01uF 400V 10%	CQ2GL103K	1
C18, 22, 24	CAP. MICA, DM19F8115	CM21L168J	6
C23, 34, 37	CAP. MICA, DM15175015	CM2CL750J	3
C25	CAP. DISK CER, 3300pF 500V 10%	CK2H133K	1
C26	CAP. DISK CER, 0.1uF 25V 20%	CK1EL104Z	1
C27	CAP. ELFC, 470uF 25V 20% SM	CE1EL47R	1
C28, 31, 32	CAP. DISK CER, 0.1uF 25V 20%	CK1EL104Z	3
C33	CAP. MICA, DM15F2715	CM2CL27J	1
C35	CAP. MICA, DM15F2015	CM2CL20J	1
C36	CAP. MICA, DM15F1515	CM2CL15J	1
T1	TRANSFORMER	TRF-006	1
T2	TRANSFORMER	TRF-007	1

T3	TRANSFORMER	TRF-008	1
T4	TRANSFORMER	TRF-009	1
L1	COIL, 0.7mm, D=5, T=6	IND-006	1
L2	COIL, 0.7mm, D=5, T=5	IND-007	1
L3	COIL, 0.7mm, D=5, T=12	IND-008	1
L4, L6	COIL, CHOKE, 33uH	IND-004	2
L5	COIL, 1.6mm, F=200mm HEAD	IND-009	2
L8, L9	COIL, 0.8mm, D=8, T=8	IND-011	2
X1	CRYSTAL, HC-197U, 40 680MHz	X11-002	1
P1	CONNECTOR, W. 5045-06A MOLEX	CON-004	1
P2	CONNECTOR, R. 8981-4V	CON-027-1	1
P3	PIN JACK, PJ-001	CON-113	1

A12. SEALING HEAD UNIT (PART NO. : 200-022-2)				
FINO NO.	DESCRIPTION	PART NO.	Lim	QTY
1	UPPER CASE, S	401-148-5		1
2	SCREW	MCC01-081		10
3	SOLENOID	102-003-6		1
4	SCREW	MIN-DJAINS		2
5	TR BUSHING	602-002		2
6	PROTECTOR	401-100		1
7	TITANIUM-WHEEL SCREW	301-070		1
8	SCREW	MPC01A681		8
9	MATCHING BOARD CASE	401-142		1
10	STANDOFF M3 X 12 STUP	101-029		2
11	WASHER, PL	WPI03-001		2
12	STANDOFF M3 X 25 THROUGH	101-032		2
13	SIBELD COVER, B	401-143		1
14	BOTTOM CASE	401-216		1
15	SOLENOID M7 HKT	401-105		1
16	SCREW	MPC04A101		4
17	CONNECTOR, DNC	CON-104		1
18	WASHER, PL	WPI03-001		2
19	WASHER, SP	WS103-005		2
20	NUT	NIT03-001		2
21	SCREW	MCC03-101		2
A8	MATCHING BOARD ASSEMBLY	600-034-2	0	1
A9	SWITCH BOARD ASSEMBLY	600-039	0	1
A10	TRIGGER BOARD ASSY	600-036-2	0	1
A11	SEALING HEAD ASSEMBLY	100-038-3		1

A8, MATCHING BOARD ASSEMBLY (PART NO. : 600-038-2)				
FIND NO.	DESCRIPTION	PART NO.	List	QTY
	PCB, MATCHING BOARD	601-038		1
RF OUT	TEST PIN	TER-009		1
C1	CAP. MICA, DM15R620J5	CM3CL620J		1
	LOADING COIL ASSEMBLY	300-061		1
	TEST PIN	TER-018		3
RF IN	WIRING HARNESS ASS'Y, BNC-MAT	WHS-068-2		1
	SHIELD WIRE	WIR-008		1

A10, TRIGGER BOARD ASSEMBLY (PART NO. : 600-036-2)				
FIND NO.	DESCRIPTION	PART NO.	List	QTY
	PCB, TRIGGER BOARD	601-036		1
LD1	LED, DL-11S2RNI RED DIA=3	LED-001		1
LD2	LED, DL-11S2GNI GRN DIA=3	LED-002		1
R1	RES. CF, 1.2K-OHM 1/4W 5%	RD08P122J		1
R2	RES. CF, 160-OHM 1/4W 5%	RD08P161J		1
P1	WIRING HARNESS, TRG TO CONT	WHS-065		1
P2	WIRING HARNESS, TRG TO LIMIT	WHS-066		1

A9, SWITCH BOARD ASSEMBLY (PART NO. : 600-059)				
FIND NO.	DESCRIPTION	PART NO.	List	QTY
	PCB, SWITCH BOARD	601-059		1
P1	CONNECTOR, W.5045-05A MOLEX	CON-003		1
P2	CONNECTOR, W.5273-02A MOLEX	CON-006		1
P3	CONNECTOR, W.5273-05A MOLEX	CON-016		1
C1-C4	CAP.DISK CER, 1000pF 25V 20%	CK1EL102Z		4
D1	DIODE, ZENER, 9V	ZCR-003		1
SW1	SWITCH, SLIDE, MS23A-P4	SW1-018		1