

TECHNICAL MANUAL

MASTER PCA

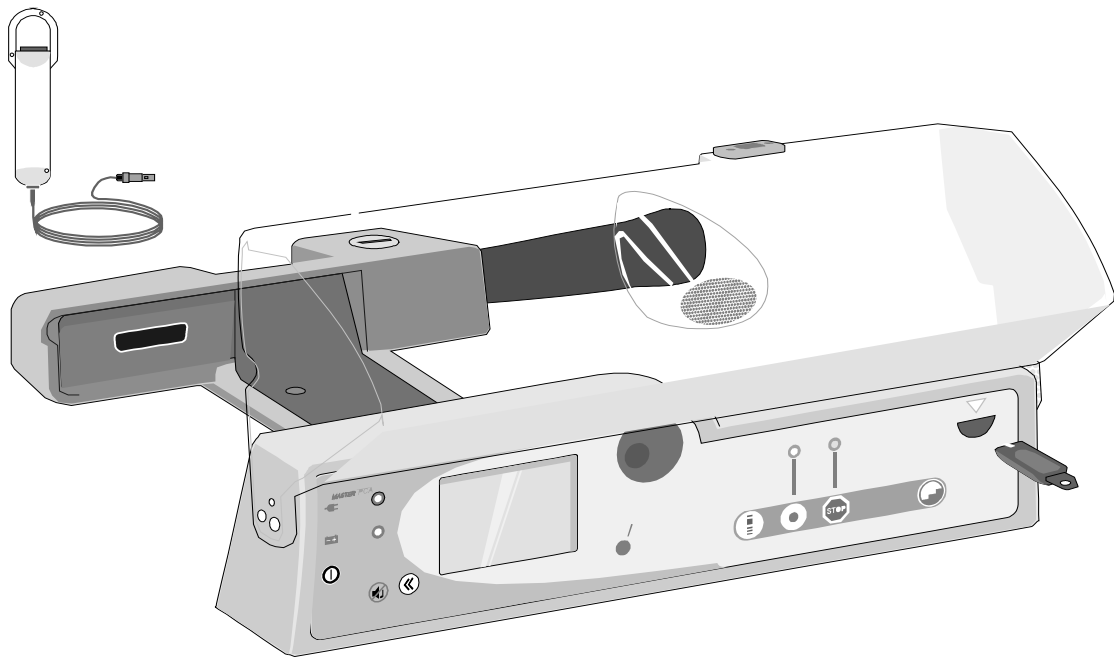

TABLE OF MODIFICATIONS

Information in this Technical manual only refers to devices belonging to the Master PCA.

- File reference :NT 0850
- Revision date :May 1999
- Applicability from serial N°16230001

Date	Revision number	Pages	Modifications
May 1999	rev AO	All	Creation

Please note: No responsibility whatsoever can be taken by Fresenius Vial S.A for any fundamental change to product specifications (specifications, performance ratings, etc.) made by non-company technician. Small repairs may be carried out by the appropriate maintenance team, at the discretion of the end user and subject to his or her responsibility. We nevertheless recommend that service personnel first attend a training course organised by Fresenius Vial S.A.

It is possible that this document contains errors or typing mistakes. Changes may be made at regular intervals, for inclusion in subsequent editions.. Thank you for your understanding.

COPYRIGHT © 1998 by Fresenius Vial S.A. This technical manual may not be reproduced in whole or in part without the written consent of Fresenius Vial S.A.

Fresenius Vial S.A. - head office : Le Grand Chemin - 38590 Brézins (FRANCE) - With directory and supervision board, capital : 90128000 F - SIREN Grenoble B 408 720 282.

TABLE OF CONTENT

1. OVERVIEW.....	3
1.1. General description	3
1.2. Block diagram	3
1.3. Precautions before use	3
1.4. Internal safety features.....	4
1.5. Technical characteristics	4
1.5.1. Device characteristics	4
1.5.2. Biological specifications	7
1.5.3. Mechanical characteristics	7
1.5.4. Dimensions / Weight	7
1.5.5. Electrical characteristics.....	7
1.5.6. Electronic characteristics.....	7
1.5.7. Master PCA Operator's Guide.....	7
1.5.8. Components used for manufacturing	7
1.5.9. Compliance	7
1.5.10. Registrations cards.....	7
2. ELECTRONIC BOARDS	8
2.1. CPU BOARD	8
2.1.1. Functional description	8
2.1.2. Regulation - Power supply.....	8
2.1.3. Watch dog	9
2.1.4. Communication modules.....	10
2.1.5. Error message.....	12
2.1.6. BUS I2C	14
2.1.7. Master/ Pilot link	15
2.1.8. Command inputs and visualisation.....	15
2.1.9. Description of connectors.....	19
2.1.10. Electronic layout	21
2.1.11. Installation layout.....	21
2.2. ALARM LEDS BOARD.....	22
2.2.1. Description of the connector J1	22
2.2.2. Electrical layout -	22
2.2.3. Installation layout.....	22
2.3. INFUSION LEDS BOARD	22
2.3.1. Description of the connector J1	22
2.3.2. Electronic layout	22
2.3.3. Installation layout.....	22
2.4. FLEXIBLE LINK BOARD	23
2.4.1. Description of the connectors.....	23
2.4.2. Electronic layout	24
2.4.3. Implantation layout	24
3. CONFIGURATIONS, CALIBRATIONS AND CHECK	24
3.1. Configurations	24
3.1.1. Configuration EPROM.....	25
3.1.2. Flash EPROM configuration	25
3.2. Calibrations	25
3.3. Check	25
3.3.1. Electrical safety tests.....	25
3.3.2. Integrated tests.....	25
3.3.3. Test mode	25

4. REPLACING SUB-ASSEMBLIES.....	29
4.1. Replacing the electronic circuit boards.....	29
4.2. Dismounting the support	29
4.3. Replacing the flexible circuit	29
4.4. Replacing the handle	29
5. MAINTENANCE	30
5.1. Cleaning and disinfecting	30
5.2. Storage	30
5.3. Servicing	30
5.4. Regular inspections - Preventive maintenance	30
5.4.1. Before using checking	30
5.4.2. Preventive maintenance	30
5.4.3. Internal historical saving battery	31
6. ANNEX 1 : ILLUSTRATED PARTS LIST	33
6.1. Traceability	33
6.1.1. Introduction.....	33
6.1.2. traceability table.....	34
6.2. General view	36
6.3. Mechanical parts list.....	37
6.3.1. Aluminium support.....	37
6.3.2. Front panel	37
6.3.3. cover.....	38
6.3.4. Locker.....	38
6.4. Electronic parts list.....	39
6.4.1. Programmation pass	39
6.4.2. Control and command	39
6.4.3. Electronic.....	39
6.4.4. Patient hand switch	39
6.4.5. Connectors	39
7. ANNEX 2 : INSTALLATION AND ELECTRONIC LAYOUTS	40
7.1. CPU BOARD.....	40
7.2. ALARM LEDS BOARD	40
7.3. INFUSION LEDS BOARD	40
7.4. FLEXIBLE LINK BOARD	40
8. ADDENDA AND INFORMATIONS.....	41
9. USEFUL ADDRESSES.....	43

1. OVERVIEW

1.1. General description

Information in this document only refers to devices belonging to the Master PCA. No responsibility whatsoever can be taken by Vial Medical for any fundamental change to product specifications (specifications, performance ratings, etc.) made by non-company personnel.

Routine repairs may be carried out by the appropriate maintenance team, at the discretion of the end user and subject to his or her responsibility. We nevertheless recommend that Maintenance personnel first attend a training course organised by Vial Medical.

The symbol  visible on the condensed instruction guide of the device, recommends the Operator Guide should be completely read, in accordance with the EN 60 601-1 Standard.

1.2. Block diagram

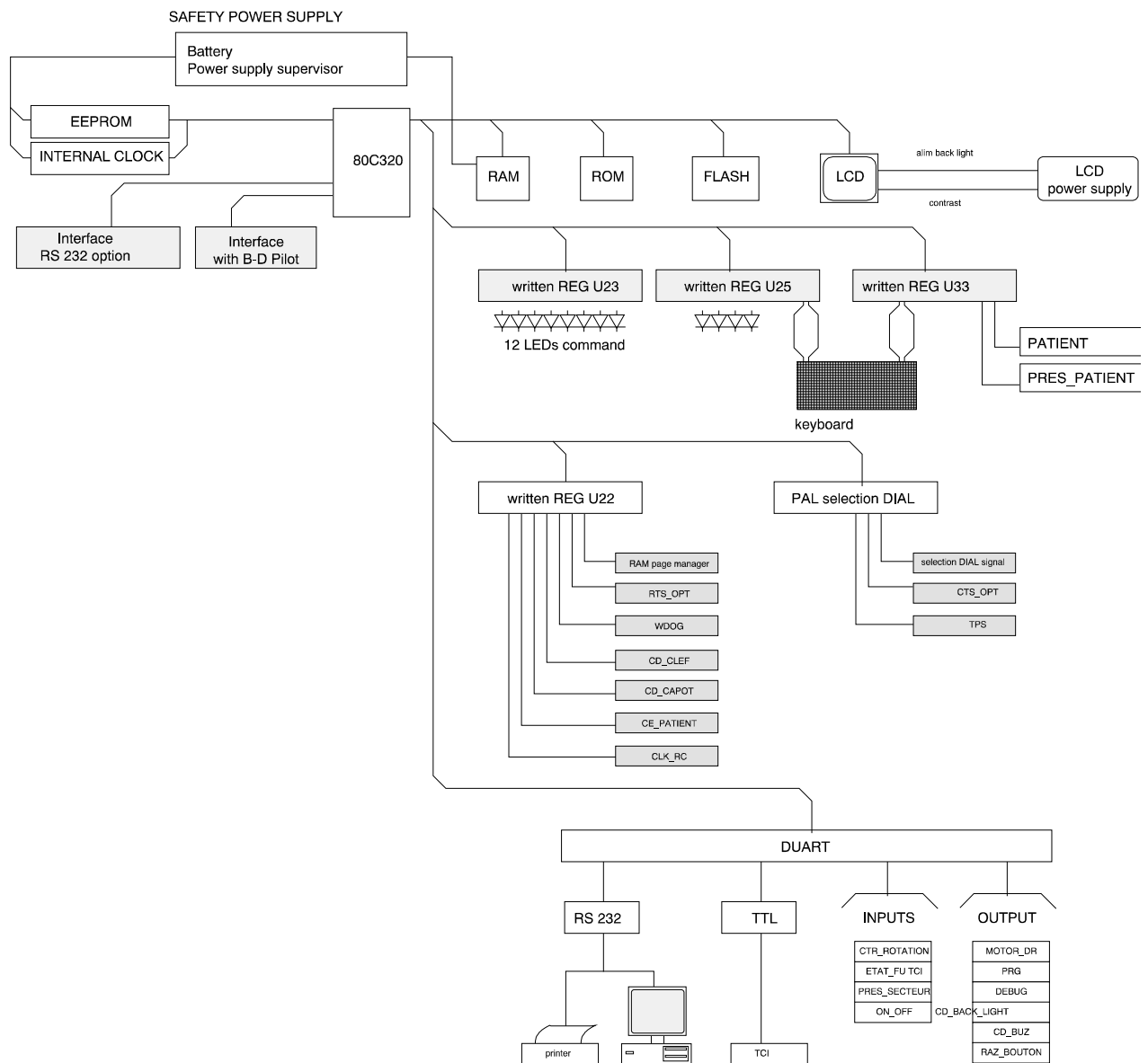

1.3. Precautions before use

Please consult Operator's guide

1.4. Internal safety features

The Master PCA is equipped with a continuous functions inspection system activated as soon as the Master is switched ON. Any failure or anomaly in the procedure is immediately detected. Nevertheless, qualified staff of your organisation or our After Sales Service should always be notified in case of abnormal functioning (see useful addresses, chapter 9)

1.5. Technical characteristics

The Master PCA is controlled by a keyboard and a rotary knob. The parameters input by the user, the infusion parameters, and parameters describing the instrument status may be visualised by means of a graphic LCD screen.

1.5.1. Device characteristics

1.5.1.1. Accuracy on average delivered flow rate.

- Accuracy of the $\pm 1 \%$
- Accuracy on the internal diameter of the syringes $\pm 2 \%$

1.5.1.2. Average accuracy on the bolus

This table is valid for a Pilot Anæsthésia or a Pilot C.

Syringe	BD PLASTIPAK 20 cc	BD PLASTIPAK 50 CC
Volume	0,2 ml à 0,8 ml	0,2 ml à 2 ml
average error	< - 0,2 %	< - 0,15 %

Used tubing: SE 1400 S

These measurements are performed in compliance with PrEN60 601-2-24 comply.

1.5.1.3. Bolus volumes and flow rates

Syringe	BD PLASTIPAK 20 cc	BD PLASTIPAK 50 CC
Volume	0,2 ml to 10 ml	0,2 ml to 30 ml
Injection duration	Flash to 15 min	Flash to 15 min
Minimum flow rate	0,8 ml/h	0,8 ml/h

Used tubing: SE 1400 S

The maximum flow rate is limited by the performances of Pilot C and Anæsthésia. See connected Pilot operator's guide to know the flow rate limitation.

1.5.1.4. Exactness and accuracy of the displayed values of massic flow rate

According to concentration and massic flow rate, the Master PCA rounds the result of volumic flow rate at the first lower value programmable on the Pilot.

Conversion diagram :

The following diagram allows to determine the error versus the programmed value

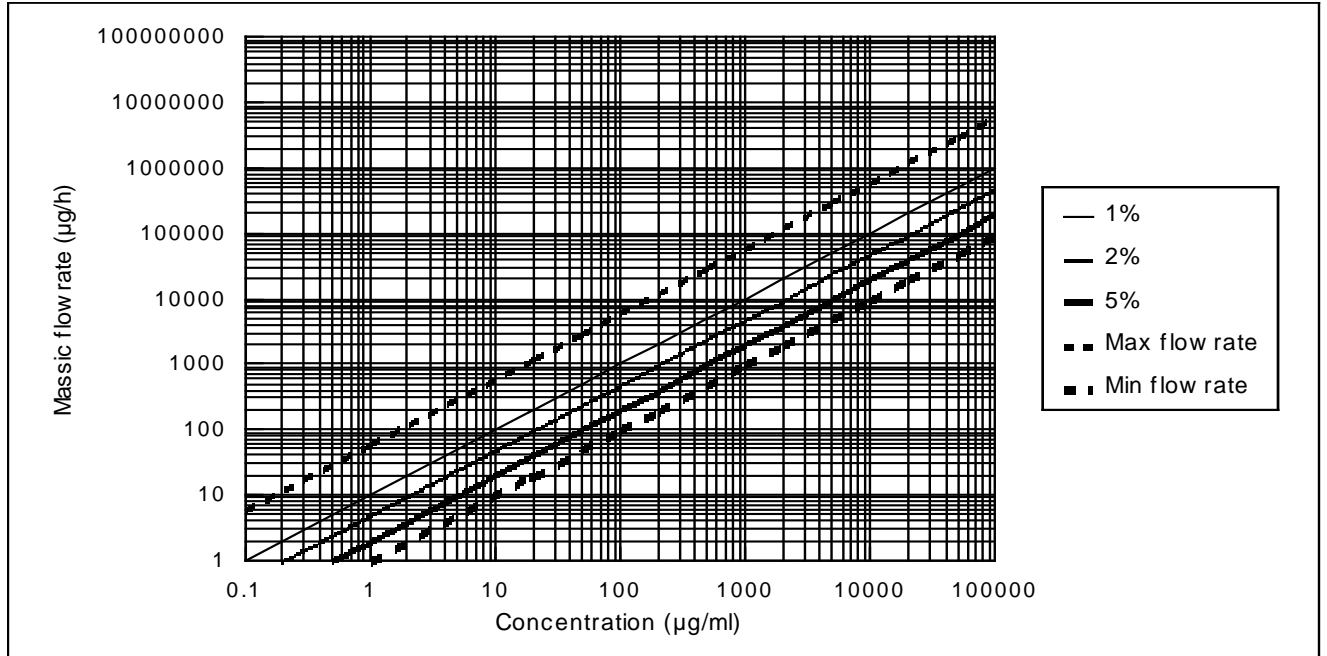

1.5.1.5. Exactness and accuracy of the displayed mass values of bolus

As for the massic flow rate, the mass of the bolus is under rounded.

- Error on bolus mass..... < - 0,5 %

1.5.1.6. Accuracy on time

- Error on the locking time. < 1 s

1.5.1.7. Syringes list

	50cc / 60 cc	20 cc
B-D Perfusion	•	
B-D Plastipak	•	•
Braun Omnifix	•	•
Braun Perfusor	•	•
Didactic line France	•	
Didactic Perfusion	•	
Dispomed	•	
Dipomed type P	•	
Fresenius Injectomat	•	

	50cc / 60 cc	20 cc
Fresenius P Spritze	•	
Sherwood Monoject	•	•
Ivac	•	
Map Gliss LL	•	
Map Pic indolor	•	
Terumo	•	•
Tutoject type T	•	
Zeneca PFS	•	

1.5.1.8. Pressure limit

The selection values of the pressure limit threshold are changeable by configuration from the key board. (See operator's guide of the connected Pilot for the operating procedure and the display accuracy). The threshold values or the pressure limits applied by default are the ones programmed on the Pilot.

1.5.1.9. Pressure management

- Occlusion pre-alarm and alarms.
- Disconnection / pressure drop alarm.

1.5.1.10. Occlusion alarm delay according to the infusion flow rate

Correspondences tables between occlusion alarm delay and programmed flow rate for three selectable pressure limits in three pre-adjusted threshold mode. These tables shows obviously that it is very interesting to choose, as soon as possible, the lowest alarm threshold to get the short test alarm delay.

The variable threshold mode allows to select continuously the best adapted value.

Syringe	Flow rate	Low limit 300 mmHg	Medium limit 500 mmHg	High limit 900 mmHg
Bd Plastipak 50 cc	1 ml/h	16'20	30'25	49'50
	5 ml/h	3'40	5'19	11'30
Bd Plastipak 20 cc	1 ml/h	6'20	12'35	17'45
	5 ml/h	45"	1'45	3'05

1 bar = 750 mmHg = 1000 hPa

Used tubing: SE 1400 S

1.5.1.11. Bolus volume at occlusion ending.

When occlusion is detected, the anti-bolus system is activated. By measuring the pressing dynamic strength, the reduction of the bolus at occlusion ending is performed according to the specific characteristics of each selectable syringe.

This principle allows to much reduce this bolus whoever the flow rate and the alarm threshold adjustment be.

Syringe	Flow rate	Low limit 300 mmHg	Medium limit 500 mmHg	High limit 900 mmHg
Bd Plastipak 50 cc	1 ml/h	≤ 0,1 ml	≤ 0,2 ml	≤ 0,2 ml
	5 ml/h	≤ 0,1 ml	≤ 0,2 ml	≤ 0,2 ml
Bd Plastipak 20 cc	1 ml/h	≤ 0,1 ml	≤ 0,1 ml	≤ 0,1 ml
	5 ml/h	≤ 0,1 ml	≤ 0,1 ml	≤ 0,1 ml

1 bar = 750 mmHg = 1000 hPa

Used tubing: SE 1400 S

- Note : The bolus reduction at occlusion ending is signalled by the alarm LED.

1.5.2. Biological specifications

Infusion liquid only comes into contact with the syringe and associated disposable.

1.5.3. Mechanical characteristics

The mechanical system consists of an aluminium support hinged to the front casing. The electrical connections and installation are effected by pushing the Pilot backwards into the support (see the Master PCA Operator's Guide). The casing is then lowered and locked onto the Pilot. On the button side two holes to insert fixing screws are available.

1.5.4. Dimensions / Weight

- Height : 135 mm
- Width : 370 mm
- Depth : 240 mm
- Weight : 1.9 kg approximately

1.5.5. Electrical characteristics

The Master PCA is powered from a Pilot syringe pump. The power supply characteristics are as follows :

- Power supply : 5.4V to 7.2V DC.
- Max. consumption : 180 mA.
- Max. power consumption : 1.3 W.

1.5.6. Electronic characteristics

The Master PCA comprises the following electronic subassemblies :

- CPU circuit board.
- LCD graphic display.
- Alarm LED circuit board.
- Infusion LED circuit board.

1.5.7. Master PCA Operator's Guide

The Master PCA Operator's Guide included operating cautions is available on request from our Customer Service.

1.5.8. Components used for manufacturing

- Case.....Polycarbonate/ABS alloy
- Control buttonPolyacetal
- Fixing handle.....Polyamide
- Protection hood.....Polycarbonate
- SupportPolyurethan painted aluminium
- Keyboard.....Polyester
- LabelsPolyester

1.5.9. Compliance

See Operator's guide

1.5.10. Registrations cards

Registration information is available upon request from our After Sales Service

2. ELECTRONIC BOARDS

2.1. CPU BOARD

2.1.1. Functional description

The Master PCA CPU circuit board is built around on the 80C320 microcontroller used in open mode. This micro is equivalent to the 80C32, but its slightly modified structure gives an overall speed improvement.

Characteristics

EPROM	256 Ko
FLASH EPROM	521 Ko
RAM	128 Ko saved by a battery
EEPROM	2 Kbytes for the instrument's configuration
WATCH DOG	MAX 691 resetable and safety RAM
INTERNAL CLOCK	PCF 8583P addressable by IC bus
LED Driver	16 LED's max
Keyboard Driver	16 keys max.
Display	128 x 64 pixel screen graphics
T6963C integrated controller.	Manual adjustment of contrast
Attachments	RS TTL Master PCA / Pilot
RS 232 PC/ Master PCA.	RS 232 option
Power Supply	Continuous from 5.4 V to 7.2 V, includes regulator of slight voltage drops. Battery power safety system for the RAM and the internal clock 3.6V 60 mAh.

The CPU circuit board has the following functions :

- power supply and regulation of the module.
- communication with the module.
- link module for the Master PCA/ Pilot .
- keyboard.
- CPU, memory.
-

2.1.2. Regulation - Power supply

The regulation/power supply module consists of a linear regulator with a low drop out voltage of for which the input voltage is supply by the Pilot battery and then regulated.

2.1.2.1. ON/OFF command

The ON/OFF key of the device is connected to the CD ON input line of the Pilot. A short press on this key switch on the power supply of the Pilot. Then, the Pilot battery supplies the necessary energy to the Master PCA (mains or battery).

When pressing ON/OFF button, the microprocessor knows the status of the button by reading TOFF by the input line from U24. It prepares the switch off mode and sends the command to turn off the voltage to the Pilot using RS 232 interface from the Pilot.

2.1.2.2. Protection of the power supply

In case of breakdown of power supply, the Pilot battery provides the necessary energy to the two devices. When the Master PCA is switched off, an internal battery saves the RAM in order to keep patient's history, and the internal clock continues to be supplied.

The battery is recharged when the device is in use. When the instrument is not in use, the minimum life expectation for a fully charged battery is 2 months.

The battery voltage of the Pilot is present on the connector subD 15 points J2, connecting the Pilot to the Master PCA.

- the minimum supplied voltage which does not provoke the resetting of the device is 5.1 V.
- the maximum supply voltage is 7.2 V

J2	Description
6	VBAT
14	VBAT
5	GND
13	GND

2.1.2.3. Pre-alarms and alarms

Alarms and pre-alarms are identical to those of the Pilot. The alarm status parameters of the Pilot is transmitted via the RS 232 interface to the Master PCA.

2.1.2.4. Battery voltage levels

This voltage is measured at the battery terminals lead of the Pilot.

- pre-alarm : 5,8 V min / 6,0 V max.
- alarm : 5,6 V min / 5,8 V max.

The voltage drop between the input of the instrument's regulator and the battery is due to the internal fuse of the Pilot and various connections between. This voltage drop is 0.5 V max. for a current of 350 mA.

- the battery voltage of the Pilot can be measured inTP4

2.1.3. Watch dog

The watch dog manage the RESET line, the rising voltage of VP of the circuit voltage Vp to safety (RAM, INTERNAL CLOCK), the switching of the CE line of the RAM to keep the integrity of the data in the RAM in case of drop of the power supply is broken.

The voltage V.P. is supplied by the battery BT1.

The timer is activated by the signal WDOG generated by the output socket comprised of circuit U22 (

2.1.3.1. Voltage of Power Supply

the signal RESET is activated for a standard voltage value, after regulation, of : 4,65 V \pm 0,15 V.

2.1.3.2. Resetting

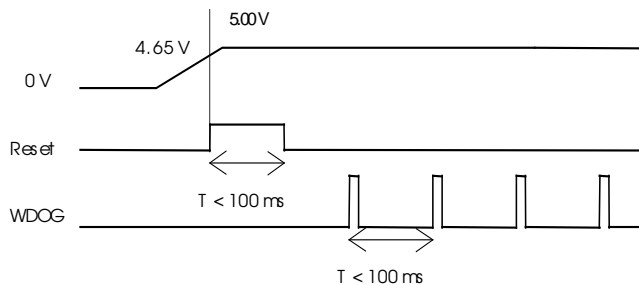

- maximum reset time of WDOG : 100 ms.
- activation of signal RESET : 200 ms.
- power supply voltage = 5.00 V \pm 0.25 V.

2.1.4. Communication modules

The CPU circuit board has 3 serial interface plug.
Connection socket for the Master PCA/ Pilot .

- RS 232-1 plug.
- RS 232-2 plug (optional).

2.1.4.1. Plug socket for the Master PCA/ Pilot

Series linking TTL of full duplex communication between the Pilot and the CPU.

2.1.4.2. Communication Master PCA/ Pilot

Two-directional series link TTL

Transmission data speed :	4800 Baud set value
	31250 Baud by software configuration
Transmission data format :	1 start bit
	7 data bit
	1 even parity bit
	1 stop bit

The signals are found on the male connector SubD 15 points J2 (connection Master PCA/ Pilot).

J2	Description
2	RXD Pilot
10	TXD Pilot
3	GND power supply

2.1.4.3. RS 232-1 connector

This connector is used for several types of communication.

2.1.4.3.1 Connection PC/ Master

Bi-directional series data RS 232-1 Bus

Transmission data speed :	4800, 9600, 19200 Baud selectable in configuration menu
Transmission data format :	1 start bit
	7 data bit
	1 even parity bit
	1 stop bit

2.1.4.3.2 Communication Master/ Printer

This mode is permanently available when the instrument is being used to print histories.

Bi-directional link RS232 :

Transmission speed :	9600 Baud
Transmission format :	1 start bit
	8 data bit
	0 parity bit
	1 stop bit

The control of flux is carried out by a hardware link between the DTR pin of the printer to the RTS pin 8 of the Master PCA.

- When the RTS pin is at + 12 V, the Master PCA considers that the printer is ready to receive some text.

- When the printer is not connected, the RTS pin is set to - 12 V ; and the PCA therefore sends no text.

The socket signals for the 3 modes of communication are found on the female connector SubD 9 points J7.

J7	Description
2	RXD
3	TXD
7	CTS
8	RTS
5	GND

2.1.4.4. RS 232-2 connector (Optional)

The unused series link RS 232 is reserved for future extensions.

The socket signals are found on the female connector sub D 9 points J6.

J6	Description
2	RXD
3	TXD
7	CTS
8	RTS
5	GRD

2.1.5. Error message

During the process of linking between the Master PCA and the Pilot . The following types of breakdown are detected and displayed on the LCD display screen.

Three types of messages are displayed:

❑ Alarms:

Code	Description	Variable state
10	Low battery	bit 10
11	Wrong position of the syringe	bit 4
12	Empty syringe	bit 9
14	Disengagement	bit 7
15	Syringe head	bit 5
16	Occlusion	bit 6
18	Dose limit reached	bit 14
19	Wrong position of the syringe	bit 13
22	Occlusion memory	bit 2
23	Battery alarm	
25	Flange detection	

❑ Recoverable errors

They allow to continue to use the device after their detection.

Code	Description
01	Rotation control
32	Displacement control (on one segment)
52	Displacement control(during slack adjustment)
72	Displacement control (on total length)
82	Displacement control (versus flow rate)

❑ Locking errors

The locking errors, worst, allow only to switch off the device by the ON/OFF to release.

Code	Description
40	Pilot E2prom
50	Pilot ADC
60	syringe parameters
70	Motor frequency
03	Pilot communication
13	Absent Pilot
23	Link to pilot closed
33	Reception
43	Transmission
53	No answer from Pilot
63	Bad Pilot answer
73	Bad Pilot type
83	Bad Pilot version
93	Master activation mode
14	period verification
24	Rotating direction check
34	Motor period check
15	Ram Master (internal)
25	Ram Master (external)
35	EPROM Master
45	E2prom Master
55	Internal clock
65	LCD Ram
75	Uarts
16	Date / time verification
26	Date / time comparison
46	Bad records history
18	Infusion maximum value reached
28	incorrect language file
48	Volume control on motor impulse
58	Flow rate control on motor impulse
68	Stop check
78	Maximum duration

2.1.6. BUS I2C

The I2C bus is a series bus synchronous in communication with the internal clock and the EEPROM memory.

With regard to overlapping memory space between the two peripherals and to the fact that they are not addressable simultaneously, a single clock CLK I2C ensures the synchronicity of data transfer, two lines of transfer make sure of the exchange between each peripheral.

- EEPROM : 2 Kbytes 24C16 U13
- INTERNAL CLOCK : PCF 8583 P U21

Line of communication	Socket
CLK : clock generated by the microprocessor	U22.19
SDA EEPROM : line Bi-directional exchange	P 1.0
SDA HORO : line Bi-directional exchange	P 1.1

The clock is built around the circuit PCF 8583. It provides the day of the year, the month and hour. Voltage Vp of the battery BT1 ensures it is functioning via the RESET circuit, U11.

The system clock is generated by quartz X3 with frequency 32,768 kHz.

The signal frequency of HORO is 1 Hz.

A frequency control is carried out by an internal timer of the microprocessor and the value is then compared to the run time read by the bus CLK I2C.

Any differences are detected immediately. The frequency must be $1 \text{ Hz} \pm 10^{-6}$.

2.1.7. Master/ Pilot link

The linking connector Pilot / Master, J2, carries the logical information other than that described in paragraph 2.4. .

J2	Name	Function
1	MAINS LED	The Pilot tells the Master PCA that the supply is connected. The battery is in use when the signal is at logical level 1.
9	ON KEY	The ON button on the front panel is connected in parallel with that of the Pilot. The Master's ON/OFF button is connected to the input CD ON of the Pilot. A short push of the button provokes the switching-on the Pilot power supply. The Pilot battery supplies the necessary energy to the Master PCA.
11	BUZZER	The Master PCA uses the Pilot's buzzer. The buzzer is activated by setting this line to zero.
4	OPTO MOTOR	This signal is sent from the Pilot towards the instrument and then redirected towards the input pin U1-16 . This line generates an impulse with each turn of the motor from the Pilot
12	OFF KEY	This signal tells the Master PCA that the Pilot has received a command to turn off the voltage. This line changes to logical level 1 to prepare for the voltage turn-off.
6	VBAT	This line provides the energy supply from the Pilot battery.
14	VBAT	This line provides the energy supply from the Pilot battery.
5	GND	—
13	GND	—

2.1.8. Command inputs and visualisation

2.1.8.1. Keyboard

The keyboard is organised as a matrix of 4 lines and 4 columns. The role of each button is described the table below :

	line 0	line 1	line 2	line 3
column 0	ENTER (Rotary knob)			
column 1		ENTER (keyboard)	NEW PATIENT	DISPLAY
column 2		ALARM SILENCE	START	HISTORY
column 3		PRIME		STOP

The two ENTER buttons are operated separately but have the same effect. The diodes D2 to D5 act to protect against short circuiting of the outputs of U26 when two buttons of the same line are pressed simultaneously.

The columns are activated for a logical level 0 by writing in U26 at address \$1000. The status of each button for lines 0 to 3 is read by a logical level 0 from the time of activation through reading the buffer U33 at address \$2000.

The ON/OFF button is connected to the input CD ON of the Pilot via the flexible plate link (see Flexible plate link).

The ON/OFF button is activated by a logical level 0. The status of the ON/OFF button is known by the CPU by reading one of the inputs of U5 set at the address \$2800.

2.1.8.1.1 Written register

U26	Address \$5000	Set to zero at the RESET	
D0	COLUMN 0	J11-5	Active to 0
D1	COLUMN 1	J11-6	
D2	COLUMN 2	J11-7	
D3	COLUMN 3	J11-8	

The data are reproduced at the outputs of U26 by a upright front on U 26-11. Only one column is activated at a time.

2.1.8.1.2 Writing cycle

- Time between two successive readings : 5 ms
- Time kept at logical level 0 : 5 μ s
- Refresh period : 20 ms.

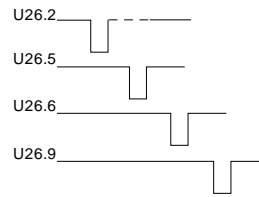

2.1.8.1.3 Read register

U24	Address \$2800	
D4	LINE 0	J11-1
D5	LINE 1	J11-2
D6	LINE 2	J11-3
D7	LINE 3	J11-4

After the addressing of each column, the status of the lines 0 to 3 are read simultaneously through the buffer U5 on the data bus.

2.1.8.2. Coder

2.1.8.2.1 Rotation

The coder is a two phases (A, B), incremental type one It includes a push button having the same function as the ENTER key. The two phases are dry contacts, the common is earthen.

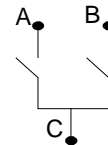

2.1.8.2.2 Coder characteristics

- 30 impulses/ 360°
- contacts normally open
- Max intensity per contact : 10 mA
- min intensity per contact : 1 mA

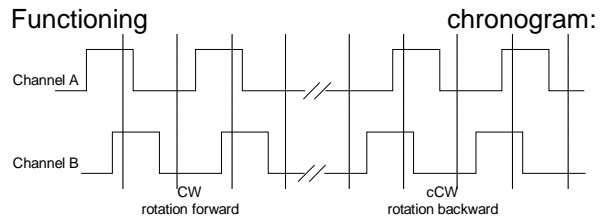

The signals from A and B are filtered to remove any erroneous coding due to rebounds of the contacts. A decoding consisting of a PAL U15 generates information for both decrementation and incrementation DEC, INC, which are reset to zero by the signal RAZ BOUTON. The information INC, DEC is read by the data bus every 5 ms.

Read and written register

U	Address \$1800
D0	DEC
D1	INC

2.1.8.2.3 Push button

The coder includes a key-sensitive push button having the same function as the enter button on the keyboard.

Pressing the push button provokes the closure of the contact. The contact is connected to the keyboard matrix.

2.1.8.2.4 Description of the coder cable

J14	Description	
1	CHANNEL B CODER	
2	CHANNEL A CODER	
3	PUSH BUTTON CODER	column 0
4	PUSH BUTTON CODER	line 0
5	GND	

2.1.8.2.5 Indicators

All the right indicators are electro-luminescent diodes. The status of each diode is defined by the level of the corresponding output in the registers U23 and U26.

2.1.8.2.6 Written records

U23	Address \$800	Set to zero at RESET
D0	INFUSION LED 1	J6.2
D1	INFUSION LED 2	J6.3
D2	INFUSION LED 3	J6.4
D3	INFUSION LED 4/START	J6.5
D4	STOP LED	J6.6
D5	OPEN	J6.7
D6	BATTERY LED	J4.2
D7	PRE ALARM LED	J4.5
U26	Address \$1000	Set to zero at reset
D4	ALARM LED	J4.4
D5	OPEN	J4.7
D6	OPEN	J4.6
D7	PATIENT LED	J2.12

2.1.8.2.7 Writing cycle

- Reset time : 10 ms
- Time kept at logical level 0 : 0.35 μ s



The electro-luminescent diodes ALARM and PRE ALARM consist of two pairs diodes set in parallel.

2.1.8.2.8 "MAINS SUPPLY PRESENT" signal

This signal is physically controlled by the signal Main LED (LED SECTEUR) given by the Pilot.

2.1.8.3. Additional outputs

The CPU circuit board has some unused peripheral outputs for its internal management, and others not in use.

U22	Address	Description
D0	PG-RAM0	This signal allows the addressing of the RAM U6 to be extended in combination with the address bit A15. The decoded memory space is a block of 32 Kbytes of addresses between \$10000 and \$1FFFF.
D1	PG-RAM1	This signal allows the addressing of the RAM to be extended in combination with the address bit A15 and PG-RAM1. The supplementary decoded memory space is a block of 32 Kbytes of addresses between \$20000 et \$3FFFF.
D2	RTS OPT	This signal is the "Request to Send" of the RS 232-2 link before conversion of the voltage level.
D3	WDOG	This signal is connected to the input WDI of U11. It's the activation signal for the watch-dog.
D4	CD CLEF	This signal allows to detect the key state.
D5	CD CAPOT	This signal allows to detect the hood state.
D6	CD PATIENT.	This signal allows to detect the patient hand set state.
D7	CLK I2C .	This signal is the clock for activation of the bus I2C.

2.1.8.4. CPU circuit board configuration

The CPU board is configured to be able to function with a program in EPROM or in flash EPROM.

- The configuration is carried out by contacts G1, G7 and G6.

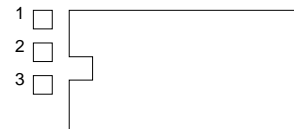

2.1.8.4.1 Configuration EPROM

The circuit board can be fitted out with an EPROM 27C512 to 27C040, of 100 ms access time.

G1 and G7	open	EPROM type
G6	2.3	EPROM 27C010, 020, 040
G6	1.2	EPROM 27C512

2.1.8.4.2 Configuration flash EPROM

The board is fitted with a flash EPROM 28F004.

- G1 and G7 closed using FLASH EPROM

2.1.9. Description of connectors

2.1.9.1. J2 : connection to the Pilot and external peripherals

This connector is attached to a flexible plate which redistributes signals to the Pilot and to the external connectors.

Pin	Description	
1	GND	power supply
2	RTS	printer
3	TXD	printer
4	RIS	printer
5	RXD	printer
6	GND	power supply
7	CTS	option
8	TXD	option
9	RTS	option
10	RXD	option
11	V BAT	power supply
12	PATIENT LED	LED patient hand switch
13	PATIENT	patient hand switch input
14	CD PATIENT CALL	patient hand switch output
15	GRD	power supply
16	LOCK	hood state input
17	CD ILS LOCK	hood state output
18	VBAT	power supply
19	VBAT	power supply
20	GND	power supply
21	GND	power supply
22	TP8	not in use
23	CTR MOT	motor rotation
24	CD BUZZER	BUZZER command
25	GND	power supply
26	TXD	Pilot
27	RXD	Pilot
28	TON	stop command
29	LED SUPPLY	supply presence
30	GND	power supply

2.1.9.2. J3 : connector for LCD display

Pin	Description	
1	GND	power supply
2	GND	power supply
3	+ 5V	power supply
4	BACK PLANE	polarisation display
5	WR*	transmission control line
6	RD*	reception control line

7	CD LCD	line for validation of memory space
8	A00	line address A00
9	RESET*	initialisation display
10	D0	data line D0
11	D1	data line D1
12	D2	data line D2
13	D3	data line D3
14	D4	data line D4
15	D5	data line D5
16	D6	data line D6
17	D7	data line D7
18	GND	power supply

2.1.9.3. J4 : alarm display connector

Pin	Description	
1	GND	power supply
2	BATTERY LED	alarm circuit
3	SUPPLY LED	alarm circuit
4	ALARM LED	alarm circuit
5	PRE-ALARM LED	alarm circuit
6	NU	not in use
7	NU	not in use
8	GND	power supply

2.1.9.4. J6 : infusion display connector

Pin	Description	
1	GND	power supply
2	INFUSION 1 LED	power supply
3	INFUSION 2 LED	power supply
4	INFUSION 3 LED	power supply
5	INFUSION 4/START LED	On signal
6	STOP	Stop signal
7	NU	not in use
8	GND	power supply

2.1.9.5. J8 : Volume control connector

Pin	Description	
1	Motor impulse	Volume control
2	Motor direction	not in use

2.1.9.6. J9 : connector back light of the display

Pin	Description	
1	BACK LIGHT ANODE +5V	back light anode
2	BACK LIGHT CATHODE	back light cathode

2.1.9.7. J10 : debug connector

Pin	Description	
1	GND	power supply
2	WR*	transmission control line
3	RD*	reception control line
4	INT UART	Interruption line 0
5	RESET*	reset line
6	DEVAL	peripheral validation
7	A15	line of address A15

2.1.9.8. J11 : keyboard connector

Pin	Description	
1	LINE 0	keyboard matrix line
2	LINE 1	keyboard matrix line
3	LINE 2	keyboard matrix line
4	LINE 3	keyboard matrix column
5	COLUMN 0	keyboard matrix column
6	COLUMN 1	keyboard matrix column
7	COLUMN 2	keyboard matrix column
8	COLUMN 3	
9	T ON OFF	ON/OFF
10	GND	power supply

2.1.9.9. J12 : power supply monitor connector

Pin	Description	
1	VBAT FILTRED	filtered power supply
2	GND	power supply

2.1.9.10. J14 : connector coder

Pin	Description		
1	CHANNEL B CODER	decoding PAL	
2	CHANNEL A CODER	decoding PAL	
3	GND	power supply	
4	CODER PUSH BUTTON	keyboard matrix	column 0
5	CODER PUSH BUTTON	keyboard matrix	line 0
6	GND	power supply	
7	+5V	power supply	
8	CD KEY	key presence detector	
9	CD KEY	not in use	
10	GND	power supply	

2.1.10. Electronic layout

See Annex 2.

2.1.11. Installation layout

See Annex 2.

2.2. ALARM LEDS BOARD

2.2.1. Description of the connector J1

This connector joins the LED's to the elevated current outputs from the CPU board. It is connected via J4 on the CPU board.

Pin	Description	
1	GND	power supply
2	MAIN LED	alarm circuit
3	MAIN LED	alarm circuit
4	ALARM LED	alarm circuit
5	PRE ALARM LED	alarm circuit
6	NU	not in use
7	NU	not in use
8	GND	power supply

2.2.2. Electrical layout -

See Annex 2

2.2.3. Installation layout

See Annex 2.

2.3. INFUSION LEDS BOARD

2.3.1. Description of the connector J1

This connector joins the LED's to the outputs at an elevated current outputs from the CPU board. It is connected via J6 on the CPU board.

Pin	Description	
1	GND	power supply
2	INFUSION LED 1/ON	infusion circuit
3	INFUSION LED 2	infusion circuit
4	INFUSION LED 3	infusion circuit
5	INFUSION LED 4	infusion circuit
6	LED STOP	infusion circuit
7	NU	not used
8	GND	power supply

2.3.2. Electronic layout .

See Annex 2.

2.3.3. Installation layout

See Annex 2.

2.4. FLEXIBLE LINK BOARD

2.4.1. Description of the connectors

2.4.1.1. J1 : link connector to the flexible plate

This connector joins the Pilot and the RS 232 input socket to the CPU board.

Pin	Description	
1	GND	power supply
2	CTS	printer
3	TXD	printer
4	RTS	printer
5	RXD	printer
6	GND	power supply
7	CTS	option
8	TXD	option
9	RTS	option
10	RXD	option
11	VBAT	power supply
12	LED INF	hand switch Led anode
13	RETURN PATIENT CALL	hand switch LED cathode
14	CD PATIENT CALL	not in use
15	GND	power supply
16	RETURN ILS LOCK	hood contact
17	CD ILS LOCK	hood contact
18	VBAT	power supply
19	VBAT	power supply
20	GND	power supply
21	GND	power supply
22	OFF BUTTON	not in use
23	OPTO MOTOR	rotation motor
24	BUZZER	start command for the BUZZER
25	GND	power supply
26	TXD MASTER	Pilot
27	RXD MASTER	Pilot
28	ON BUTTON	ON/OFF switch
29	LED SUPPLY	supply presence
30	GND	power supply

2.4.1.2. J7 : series link connector for printer

Pin	Description	
1	NC	not in use
2	RXD	printer
3	TXD	printer
4	NC	not in use
5	GND	power supply
6	NU	not in use
7	RTS U	printer
8	CTS	printer
9	NU	not in use

2.4.1.3. J6 : optional series link connector

Pin	Description	
1	NC	not in use
2	RXD	option
3	TXD	option
4	NC	not in use
5	GND	power supply
6	NC	not in use
7	RTS	option
8	CTS	option
9	NC	not in use

2.4.1.4. J2 : connector linking Pilot

Pin	Description	
1	LED SUPPLY	supply presence
2	RXD MASTER	Pilot
3	GND	power supply
4	OPTO MOTOR	rotation motor
5	GND	power supply
6	VBAT	power supply
7	NU	not in use
8	NU	not in use
9	ON BUTTON	ON/OFF switch
10	TXD MASTER	Pilot
11	BUZZER	buzzer command
12	OFF BUTTON	stop button
13	GND	power supply
14	VBAT	power supply
15	NU	not in use

2.4.1.5. J3 :

not installed

2.4.1.6. J5 : hand set connector

This connector is destined to be used in PCS mode.

Pin	Description	
1	CATHOD	Hand set LED
2	HAND SET CONTACT	hand set contact
3	HAND SET CONTACT	hand set contact
4	ANOD	Hand set LED

2.4.2. Electronic layout .

See Annex : 2.

2.4.3. Implantation layout

See Annex : 2.

3. CONFIGURATIONS, CALIBRATIONS AND CHECK

3.1. Configurations

CPU board configuration

CPU board is configurable to work with an EPROM or FLASH EPROM program.
Configuration is carried out by the drops G1, G7 et G6.

3.1.1. Configuration EPROM

The board can be equipped with a 27C512 to 27C040 EPROM, access time : 100 ms.

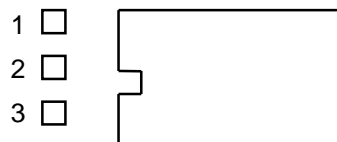

G1 et G7	open	EPROM use
G6	2.3	EPROM 27C010, 020, 040
G6	1.2	EPROM 27C512

3.1.2. Flash EPROM configuration

The board is equipped of a 28F004 flash EPROM

G1 et G7	closed	FLASH EPROM use
----------	--------	-----------------

For the other configurations see operator's guide.

3.2. Calibrations

Aimless

3.3. Check

3.3.1. Electrical safety tests

In compliance with EN 60 601.1 complies.

3.3.2. Integrated tests

The device has integrated auto-tests of the following components :



- Screen .
- LED's .
- Keyboard .
- Rotary knob .
- Serial links .
- Internal clock.

The tests can be perform with a Pilot CE 0459 or with an external power supply of 7 V via the 15 points sub D connector.

The following polarisation must be respected in this case. The pin 10 should be connected to the pin 2.

Pin	Description	
6	+ 7 V	Power supply
14	+ 7 V	Power supply
5	GND	Power supply
13	GND	Power supply
2	RXD	Pilot
10	TXD	Pilot

3.3.3. Test mode

Press the two buttons simultaneously during the instrument auto-test SILENCE  + START .

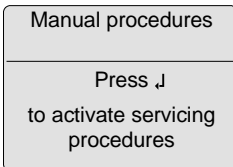

The screen shown here invites the user to enter the test mode by pressing ENTER .

If the user doesn't quickly validate the entry into this mode, the instrument will return to the programming menu.

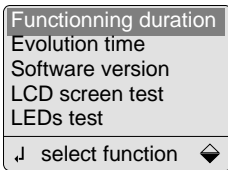

A turn of the Dial  allows the user to select the type of test or to display information.



Pressing STOP  allows the user to leave the test and return to the selection menu.

3.3.3.1. Functioning duration



This screen displays the following information :

- total instrument running time.
- total usage time since the last use.

The instrument assumes that the average length of a month is 30 days. Successive action on  and  allows one to change the maintenance date.

The time elapsed since the last maintenance is renewed after modification of the maintenance date.

3.3.3.2. Evolution dates

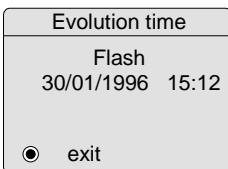

This screen displays the last evolution dates and time :
- date and time of loading the Master PCA application in flash memory.

3.3.3.3. Software version

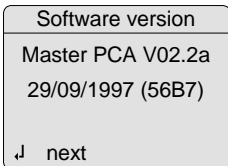

This screen displays the numbers of the software versions :

- version, revision of the Master PCA application.
- date generated and the checksum of the software.



Pressing  displays the language screens :

- language.
- version, revision of the files as well as the creation date of the language.

All the different screens can be consecutively displayed using the rotary knob.

3.3.3.4. Screen LCD test



This test alternates between lighting all the pixels then every odd pixels, even pixels.

3.3.3.5. LED's test

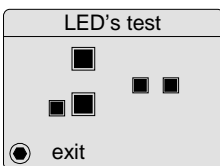

This screen shows the status of the display LED's.

At the onset of this test, all the LED's are illuminated at the same time for 3 s.

3.3.3.6. Keyboard test

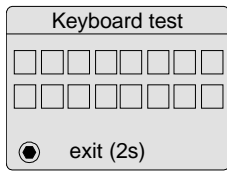

This screen shows the positions of the buttons according to the following order :

- squares 1 to 4 : line 0 column 0 to 3.
- squares 5 to 8 : line 1 column 0 to 3.
- squares 9 to 12 : line 2 column 0 to 3.
- squares 13 to 16 : line 3 column 0 to 3.

As soon as the button is pressed the corresponding symbol appears on the screen in the case according to how its matrix is organised. To stop the test, it is necessary to hold down the STOP button for more than 2 seconds.

3.3.3.7. Rotary knob test

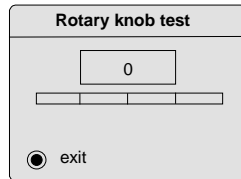

This screen shows the number of impulses made by the rotary knob in rotating as well as an indication of the speed by means of a bar-graph. The sense of rotation is the same as that shown on the horizontal scale.

- a single bar corresponds to slow speeds.
- two bars correspond to greater speeds.

3.3.3.8. Patient switch test

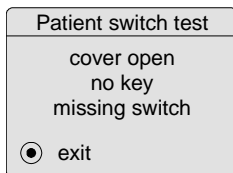

This screen shows the state of the cover, programming key and patient switch
Important : to check Hand set functionality, the wiring layout must be respected.

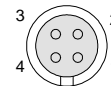

- 1 : Patient switch LED cathode
- 2 : Patient switch contact
- 3 : Patient switch contact
- 4 : Patient switch LED anode

3.3.3.9. Serial link test

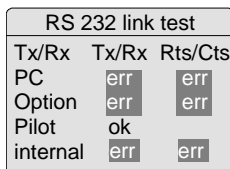

Before carrying out this test, it's necessary to fitted the device with test plugs made from subD 9 points with TxD and RxD links and a second link between CTS and RTS. This plug equip the RS232-1 links (PC link).

This screen shows the states of the different serial link lines. If one link is defective, the error message will appear.

3.3.3.10. Latest events

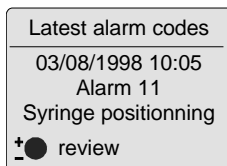

This test allows to check the last 10 events. Each event is display on one screen-page, each screen-page is selected with the rotary knob The events are numbered chronologically with the last as number 1.

The possible errors are out of 3 types : see §2.15 for details

3.3.3.11. Clock period

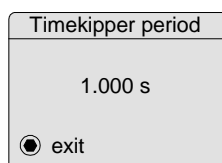

This screen displays the measurement of the internal period clock which is cyclically updated. For correct functioning of the instrument, the displayed value must equal 1.000 s.

3.3.3.12. Pilot information

This test extracts information on the latest 3 connected Pilots. Each Pilot number is displayed on one screen-page, and each page is selected using the rotary knob. The different screens are numbered chronologically with the most recent numbered 1.

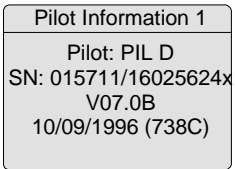

This screen displays the following information :

- Pilot type.
- series number of the Pilot.
- software version of the Pilot.
- date and checksum of the Pilot EPROM.

3.3.3.13. Battery load

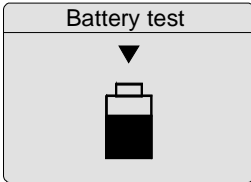

This is a timer to indicate the time spent during the menu enter after 96 hours charge, the bargraph is full and indicates that the RAM battery is fully charged.

To charge this battery:

- Connect the device to main.
- Go to test mode.
- Select : battery load
- Charge for at least 96 hours

Exit this menu reset and stop the timer.

4. REPLACING SUB-ASSEMBLIES

Important : a complete check of the instrument must be made after any internal investigation.

4.1. Replacing the electronic circuit boards

Important : be very careful with the flexible plate on opening the device.

1. Remove the 7 screws in the front face, and detach the fixing clamp.
2. Disconnect the LCD flat cable, taking care not to damage it.
3. Disconnect the connection cables from the keyboard connector, the display circuit connectors the coder connector and the flexible plate connector.
4. Take out the board, very carefully.
5. Replace the LED or the keyboard circuit if necessary.

4.2. Dismounting the support

Remove the two fixing screws on the hinge situated next to the CPU circuit board and pull.

4.3. Replacing the flexible circuit

Note : dismantling the flexible circuit systematically implies its replacement.

1. Dismantle the two connector support plates.
2. Detach the flexible circuit from the aluminium support.
3. Detach the connectors from their plate support.
4. Clean the glue from the surface with 95° methylated spirits.
5. Remove the protective sheet from the new flexible circuit, equipped with its connectors. Glue the flexible circuit making sure it is well positioned with regard to the 2 fixing screw-holes in the Pilot / Master PCA.
6. Glue on the protective film of the flexible circuit.

4.4. Replacing the handle

1. Unscrew the handle until it unclips from its socket and remove the screw from its thread.
2. Unscrew the plate enclosing the mechanism situated below the support.
3. Disengage the 2 wingnuts from their housing with pliers and pull out the set.
4. Insert a new handle into its socket.
5. Fix back the lock support plate or change the faulty parts of the lock.

5. MAINTENANCE

5.1. Cleaning and disinfecting

The Master PCA is part of the patient's immediate environment. It is advisable to clean and disinfect the device's external surfaces on a daily basis in order to protect patient and staff. Disconnect the device from its mains supply before starting to clean.

- Do not place in an AUTOCLAVE nor IMMERSE the device. Do not let liquids enter the device's casing.
- If the device is placed in a high contamination risk unit, it is advisable to leave it in the room during aerial disinfecting, after having disinfected it with a moist cloth.
- Use a cloth soaked in DETERGENT-DISINFECTANT, previously diluted with water if required, to destroy micro-organisms. Avoid abrasive scrubbing which could scratch the casing. Do not rinse or wipe surfaces.
- Do not use: TRICHLOROETHYLENE-DICHLOROETHYLENE - AMMONIA - AMMONIUM CHLORIDE - CHLORINE and AROMATIC HYDROCARBON - ETHYLENE DICHLORIDE-METHYLENE CHLORIDE - CETONE. These aggressive agents could damage the plastic parts and cause device malfunction.
- Take care also with ALCOHOL BASED SPRAYS (20% - 40% alcohol). They lead to tarnishing of and small cracks in the plastic, and do not provide the necessary cleaning prior to disinfecting. Using disinfecting applies by SPRAYS may be done, in accordance with the manufacturer recommendation, from a distance of 30 cm of the device, avoid the accumulation of the product in liquid form.

Please contact the appropriate service, handling suitable cleaning and disinfecting products, in your establishment for further details.

5.2. Storage

The device should be stored in a dry, cool place. In case of prolonged storage, the battery should be disconnected via the battery access flap situated underneath the device. This should be done by a qualified technician.

- Storage temperature: -10°C + 60°C.
- Permissive relative humidity: maxi 85%, no condensation.

5.3. Servicing

To ensure normal performance of the device, it is recommended to replace the internal battery each 3 years. This should be done by a qualified technician.

The qualified technicians in your establishment or our After-Sales Service should be informed if the device is dropped or if any of malfunction occurs. In this case, the device must not be used.

For further information concerning the pump servicing or its use, please contact our After-Sales Service or our Customer service.

If the device has to be returned to our After-Sales Department, proceed to its cleaning and disinfecting. Then, pack it very carefully, if possible in its original packaging, before sending it with a detailed description of the fault, to the official representative of Vial Medical.

Vial Medical is not liable for loss or damage to the device during transport to our After-Sales Department.

5.4. Regular inspections - Preventive maintenance

5.4.1. Before using checking

(See operator's guide of Master PCA : §14.2 page 28)

This check must be performed before every use of the Master

Note : In the framework of continuous improvement, this checklist may change any time. Please contact our after sales service for up-to-date version.(Addresses at the end of this document)

5.4.2. Preventive maintenance

(See next page : Technical check certificate)

In order to insure preventive maintenance, preventive technical check is recommended every 24 months. This technical check must be performed by qualified technician and is not covered by any contract from FRESNIUS VIAL.

For more information contact After Sale Service.(Addresses at the end of this document)

5.4.3. Internal historical saving battery

- Changing Internal historical saving battery is recommended every 2 years
- Changing this battery obliged to dismount CPU board following procedure described in § 4.1.
- Deweld battery, avoiding excess heating, short circuit and electrostatic charges when manipulate the board.
- The place of the battery is marked by a sticker.
- Prior placing a new battery make sure implant direction is correct and polarities are in accordance with serigraphy.
- Battery type is : 60 mA, CdNi, weldable Gb.
- Use procedure set up by battery maker to destroyed the removed battery.

3) Check general appearance of housing.

1. No shock mark	<input type="checkbox"/> YES - <input type="checkbox"/> NO
2. No suspect noise (turn upside down the device)	<input type="checkbox"/> YES - <input type="checkbox"/> NO
3. No permanent bending in the locking clamp	<input type="checkbox"/> YES - <input type="checkbox"/> NO
4. Goodly appearance of the keyboard and display window	<input type="checkbox"/> YES - <input type="checkbox"/> NO
5. Presence of the two locking screw Pilot / Master PCA	<input type="checkbox"/> YES - <input type="checkbox"/> NO

Verify the general appearance of the hinge

1. Small play in the articulation	<input type="checkbox"/> YES - <input type="checkbox"/> NO
2. No tear on the protective polyester film	<input type="checkbox"/> YES - <input type="checkbox"/> NO





Verify the general appearance of the handle

1. Presence of the threaded socket for handle and no permanent bending	<input type="checkbox"/> YES - <input type="checkbox"/> NO
2. No important free play	<input type="checkbox"/> YES - <input type="checkbox"/> NO
3. Efficient locking of the handle	<input type="checkbox"/> YES - <input type="checkbox"/> NO

Verify the general appearance of the cover and lock

1. No shock mark	<input type="checkbox"/> YES - <input type="checkbox"/> NO
2. No important free play in the hinge making locking uneasy	<input type="checkbox"/> YES - <input type="checkbox"/> NO
3. Efficient closing of the cover	<input type="checkbox"/> YES - <input type="checkbox"/> NO

Control battery running

1. Press  (mains disconnected) :	
- check message on the screen : Prealarm - Running on battery	<input type="checkbox"/> YES - <input type="checkbox"/> NO
- check the  light presence	<input type="checkbox"/> YES - <input type="checkbox"/> NO
2. Reconnect the mains :	
- the message "Prealarm..." appears on the screen	<input type="checkbox"/> YES - <input type="checkbox"/> NO
- the battery indicator  light switches off	<input type="checkbox"/> YES - <input type="checkbox"/> NO
- the mains indicator lights  .	<input type="checkbox"/> YES - <input type="checkbox"/> NO

Remark : it is recommended after a long no working period (> 2 months) to connect device to mains for 10 hours before using it in order to charge the historical safeguard battery.
To maintain device under main, start an infusion cycle in simple bolus with an empty syringe.

Control result comply	<input type="checkbox"/> YES -	<input type="checkbox"/> NO
-----------------------	--------------------------------	-----------------------------

Visa

6. ANNEX 1 : ILLUSTRATED PARTS LIST

6.1. Traceability

6.1.1. Introduction

The aim of this chapter is to guide technicians looking for spare parts when servicing the device.

6.1.2. traceability table

Serial number	From :....16230001 To :.....16470140	From :.....1670141 To :.....1653270	From.....16530271
UC Card	182004	182004	182004
Rotating coder	182997	182997	182989
Magnet	182208	182232	182232
Magnet support	182408	182408	182408

6.2. General view

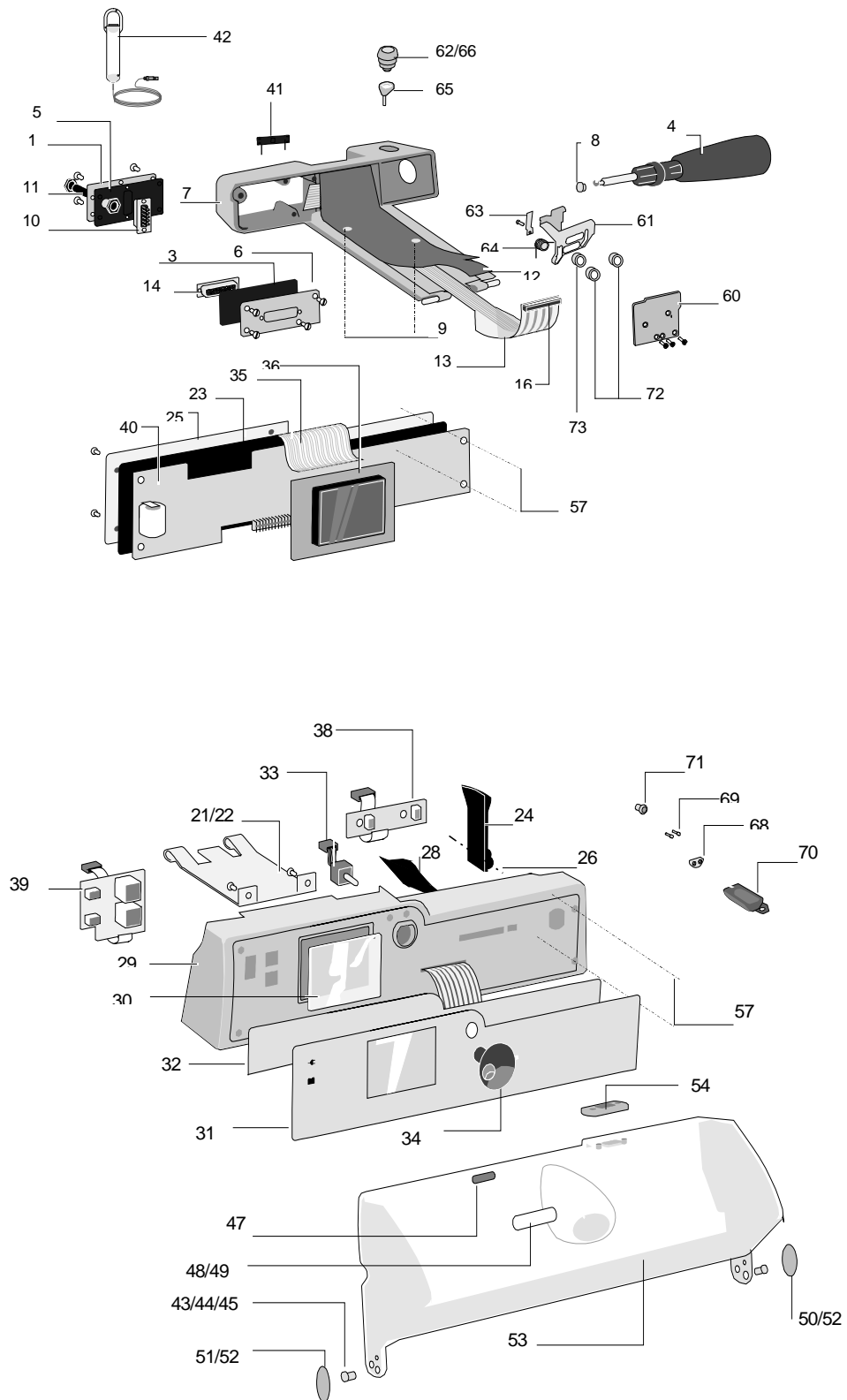

6.3. Mechanical parts list

6.3.1. Aluminium support

Ref.:	Rep:	Quantity	Description
182161	1	1	External support plate
182705	3	1	Communication foam joint
182106	4	1	Moulded complete handle
182705	5	1	External support foam joint
182157	6	1	Pilot communication plate
182205	7	1	Aluminium PCA support
182108/	8	1	Handle screw end
199593	9	2	Inox M 5* 6 split screw
199597		2	Sub d lg6 spacer
199599		10	Black TF M 3*8 Taptite screw
182779	12	1	Flexible circuit protection

6.3.2. Front panel

Ref.:	Rep:	Quantity	Description
182226	21	1	Front panel hinge
182703	22	1	Hinge plate joint
182702	23	1	Plate band joint
182124	24	1	Master lever locker lever
182155	25	1	Front panel plate
199587	26	5	ff 10h3050-5 spacer
199591	27	1	Inox Z1 M 3*40 TCB screw
182407	28	1	PCA technical closer
182128	29	1	PCA front panel
182012	30	1	Anti-blink LCD screen

6.3.3. cover

Ref.:	Rep:	Quantity	Description
190096	43	2	Nylon washer
182401	44	2	ACME 0180400 pillow-block
199570	45	2	CB M 4*16 screw
199534	46	2	Flat inox ZAN washer
182408	47	1	57050 overmoulded magnet
182223	48	1	PCA magnet support
199602	49	2	Black TF 2.5 split screw
182229	50	1	Left pin
182228	51	1	Right pin
199605	52	1	Polyamide TF M2 * 6 Nylon screw
182227	53	1	PCA cover
182207	54	1	PCA locking plate

6.3.4. Locker

Ref.:	Rep:	Quantity	Description
182162	60	1	PCA handle mechanism closer
182222	61	1	Lock bolt
182224	67	1	Cover hook
182402	62	1	Ronis 14700-22 locker
182219	63	1	Blade spring
182215	64	1	Locking spring
182230	65	1	Locker cam
182214	66	1	Ronis locker nut
199559	72	2	H5 8 * 4.2 M4 Nylstop nut
199594	73	1	Spacer

6.4. Electronic parts list

6.4.1. Programmation pass

Ref.:	Rep:	Quantity	Description
182225	68	1	Pass socket hood
182217	69	2	Pass socket contact
182204	70	1	Programmation pass
182403	71	1	Bicolor LED

6.4.2. Control and command

Ref.:	Rep:	Quantity	Description
182834	31	1	IEC / VIAL front panel
182833	31	1	DIN / VIAL front panel
182830	31	1	NEUTER front panel
182023	32	1	PCA key board
182989	33	1	HE 13 rotating coder
182100	34	1	Rotating knob
182018	35	1	Gelded LCD Flextrip
182001	36	1	MGLS graphical display
182991		1	LCD / UC link
182406	15	1	Proximity sensor

6.4.3. Electronic

Ref.:	Rep:	Quantity	Description
199598	37	5	SSR 4-3-01 spacer
182201	38	1	PCA syringe LED integrated circuit
182015	39	1	Gelded alarm LED integrated circuit
182004	40	1	PCA CPU board

6.4.4. Patient hand switch

Ref.:	Rep:	Quantity	Description
182051	11	1	Patient hand switch socket
182998	42	1	Wired patient hand switch

6.4.5. Connectors

Ref.:	Rep:	Quantity	Description
170689	10	1	9 pts sub d female connector
182010	13	1	Master flexible circuit
170688	14	1	15 pts sub d male connector
161761	16	1	6160.15.2D1200 connector

7. ANNEX 2 : Installation and Electronic layouts

7.1. CPU BOARD

Description	FV REF	REF	Rev.
Installation layout (# 2/2 x A3)	A301210	D394GS004	C2
Electrical layout (# 7/7 x A3)	A301204	D194GS000	C2

7.2. ALARM LEDS BOARD

Description	FV REF	REF	Rev.
Installation layout (#1/1 x A4)	A301334	D395GU004	B0
Electrical layout (#1/1 x A4)	A301323	D195GU000	B0

7.3. INFUSION LEDS BOARD

Description	FV REF	REF	Rev.
Installation layout (# 1/2 x A4)	A301400	D395GU009	C1
Electrical layout (# 1/1 x A4)	A301327	D195GU002	C1

7.4. FLEXIBLE LINK BOARD

Description	FV REF	REF	Rev.
Electrical layout (# 1/1 x A3)	A301199	D195CR000	B0
Printed circuit (# 1/1 x A3)	A301201	D195GU001	B0

8. ADDENDA

9. Useful addresses

All request for information or documentation (technical file, tubing catalogue or commercial documentation) should be addressed to :

CUSTOMER SERVICE INTERNATIONAL

	Fresenius Vial Le Grand Chemin, 38590 Brézins FRANCE	Tel. : 33 (0)4 76 67 10 81 or 10 54 Fax : 33 (0)4 76 65 52 22
--	--	--

AFTER-SALES SERVICES

INTERNATIONAL	Fresenius Vial Le Grand Chemin, 38590 Brézins FRANCE	Tel. : 33 (0)4 76 67 10 76 Fax : 33 (0)4 76 65 56 66
----------------------	--	---

BELGIUM	Fresenius NV/SA Belgique DIVISION VIAL MEDICAL Molenberglei 7 2627 Schelle BELGIUM	Tel. : 32/380 73 07 Fax : 32/880 50 07
----------------	--	---

GERMANY	FRESENIUS MCM AM-NEUNEN BERG 8 63749 ALZENAU GERMANY	Tel. : 49/60 23 97 22-0 Fax : 49/60 23 43 06
----------------	--	---



It is possible that this document contains typing errors or mistakes. Changes may occur at any time in subsequent editions.

COPYRIGHT © 1998, **Fresenius Vial S.A.**

This technical manual may not be reproduced in whole or in part without the written consent of **Fresenius Vial S.A.**

Fresenius Vial S.A. - siège social : Le Grand Chemin - 38590 Brézins (FRANCE)
S.A. à directoire et conseil de surveillance au capital de 90 128 000 FF - SIREN Grenoble B 408 720 282

 **Fresenius Vial**
Infusion Technology

