

nGenuity™
8100E Series
Vital Signs Monitor
Service Manual

Cat. No. 1448
Date 09/09

CE₀₄₁₃
Part No. 39166B101
Revision 2

Copyright

COPYRIGHT © CRITICARE SYSTEMS, INC. 2006–2009

CRITICARE SYSTEMS, INC., (Criticare) owns all rights to this unpublished work and intends to maintain this work as confidential. Criticare may also seek to maintain this work as an unpublished copyright. This publication is to be used solely for the purposes of reference, operation, maintenance, or repair of Criticare equipment. No part of this publication may be reproduced in any manner or disseminated for other purposes.

In the event of inadvertent or deliberate publication, Criticare intends to enforce its rights to this work under copyright laws as a published work. Those having access to this work may not copy, use, or disclose the information in this work unless expressly authorized by Criticare to do so.

All product specifications, as well as information contained in this publication, are subject to change without notice.

All information contained in this publication is believed to be correct. Criticare Systems, Inc., shall not be liable for errors contained herein nor for incidental or consequential damages in connection with the furnishing, performance, or use of this material.

This publication may refer to information and products protected by copyrights or patents and does not convey any license under the patent rights of Criticare Systems, Inc., nor the rights of others. Criticare Systems, Inc., does not assume any liability arising out of any infringements of patents or other rights of third parties.

PROPERTY OF CRITICARE SYSTEMS, INC. ALL RIGHTS RESERVED

nGenuity™ vital signs monitor, DOX™ Digital Oximetry, ComfortCuff™ NIBP, SHELL™ and Multi-Site™ SpO₂ Sensors are trademarks of Criticare Systems, Inc.

Contents

Copyright.....	ii
Contents.....	iii
Warranty.....	vii
Service Return Policy.....	viii
EC Declaration of Conformity.....	ix

Section 1 - Introduction

Description.....	1-1
Intended Use.....	1-1
nGenuity 8100E Series Options.....	1-1
Pulse Oximetry Measurement (SpO ₂)	1-2
Definition	1-2
DOX™ Digital Oximetry	1-2
Method	1-2
SpO ₂ Clinical Testing and Accuracy	1-3
Heart Rate.....	1-4
ECG Measurement	1-4
Method	1-4
Stability of Accuracy.....	1-5
Pacemaker Pulse Rejection	1-5
Respiration.....	1-5
Non-Invasive Blood Pressure (NIBP).....	1-6
Comfort Cuff™ Technology.....	1-6
Description of NIBP Measurement.....	1-6
NIBP Clinical Testing and Accuracy.....	1-7
Cuff Inflation and Pressure Protection	1-7
Capnography (Measurement of CO ₂).....	1-8
Method of Measurement	1-8
Conditions of Use.....	1-9
Stability of Accuracy.....	1-9
N ₂ O Compensation.....	1-9
Temperature Measurement	1-9
Specifications.....	1-10
Symbols	1-14
Safety.....	1-16
Definitions	1-16
Warnings.....	1-16
Cautions.....	1-17
Leakage Current	1-18
Voltage Fluctuations.....	1-18
Equipotential Ground	1-18
Software Error Related Hazard Mediation	1-18
Potential Interference.....	1-19
Biocompatibility	1-19
Latex Content.....	1-19
DEHP Content.....	1-19

Section 2 - Service Windows

Service Mode Window	2-1
Service Mode Window	2-1
NIBP Service Mode.....	2-4
Processor Software Download.....	2-5
Permanent Alarm Silence	2-6
Arrhythmia and ST Analysis.....	2-6

Service Settings	2-7
Service Password.....	2-7
Alarm Tone Warning.....	2-8
Line Frequency.....	2-8
Simulation Mode.....	2-9
Custom Profiles.....	2-10
Setting Patient Size	2-10
Creating Custom Profiles.....	2-11

Section 3 - Theory of Operation

Power Module	3-1
Main CPU and System.....	3-1
CONM Module.....	3-1
Vital Signs Module.....	3-1
Speaker Driver.....	3-1
ECG Module.....	3-2
Impedance Respiration.....	3-2
Pulse Oximeter Module (SpO ₂).....	3-3
Temperature.....	3-3
Communications.....	3-3
Printer.....	3-3
Block Diagram	3-4

Section 4 - Cleaning and Disinfecting

Cleaning and Disinfecting.....	4-1
Pulse Oximeter Sensors.....	4-1
Blood Pressure Cuffs.....	4-1
ECG Cable	4-2
Temperature Cable.....	4-3
Accidental Wetting.....	4-4

Section 5 - Preventative Maintenance

Incoming Inspection	5-1
Maintenance Schedule.....	5-1
Monitor Safety Testing	5-2
Equipment and Tools.....	5-3
Accessory Testing	5-3
Fuse Removal/Replacement	5-4
Long-Term Monitor and Battery Storage.....	5-5
Monitor and Accessories Disposal	5-5
Electrical Safety Testing.....	5-6
Equipment Needed.....	5-6
Withstanding Voltage (Hi-Pot) Test Equipment and Setup.....	5-6
Withstanding Voltage (Hi-Pot) Test Procedure.....	5-7
Leakage Test Equipment and Setup	5-8
Leakage Test Procedure	5-8
Ground Continuity Test.....	5-10
Functional Testing	5-11
Interface Inspection	5-11
Manual Controls Check	5-11
Alarms Verification.....	5-12
Printer Check.....	5-12

Module Verification	5-13
ECG Verification.....	5-13
ECG Analog Output Test	5-16
Diagnostic, Monitor, and ST Filter Mode Tests	5-17
SpO ₂ Verification	5-18
NIBP Verification	5-19
Temperature Verification.....	5-20
Communication Testing	5-21
Nurse Call	5-21
Battery and Power Testing.....	5-22
Test the Battery.....	5-22
Functional and Safety Testing Checklist.....	5-23

Section 6 - Service Testing and Calibration

Field Service Testing Safety	6-1
Field Service Test Matrix	6-2
Field Calibration Procedures.....	6-2
DOX SpO ₂ Performance Testing	6-3
Programming the SmartSat Analyzer.....	6-3
Test Procedure.....	6-3
SpO ₂ Board Test Values.....	6-4
NIBP Calibration	6-5
Installing the PC Service Program	6-5
Configuring the Ports	6-5
Calibration	6-6
NIBP Performance	6-9
Temperature Input Check	6-10
Monitor Fault Testing	6-11
Power Supply Board Test	6-11
Main Board Testing.....	6-12

Section 7 - Disassembly

Before You Begin.....	7-1
Tools Needed.....	7-1
Before You Begin	7-1
Service Safety	7-1
Electrostatic Discharge Protection	7-2
Disconnecting and Replacing the Battery	7-2
Remove the Battery	7-2
Reconnect or Replace the Battery	7-2
Printer Repair.....	7-3
Removing Printer Assembly.....	7-3
Replacing Printer Components	7-3
Reattach the Printer Assembly.....	7-3
Front Main Chassis Repair	7-4
Disassembly.....	7-4
PCB Replacement.....	7-4
Display Assembly.....	7-6
Disassembly.....	7-6
Membrane Replacement.....	7-6
Display Installation	7-6
Bottom Chassis Repair	7-7
Disassembly.....	7-7
Speaker Replacement.....	7-7
NIBP Chassis Replacement.....	7-7
Power Supply Replacement.....	7-7
Testing	7-8
Assembly Tests.....	7-9

Section 8 - Troubleshooting

Troubleshooting and Repair	8-3
ComfortCuff NIBP Module.....	8-3
ECG/Impedance Respiration Module.....	8-4
Board Settings and Module Software	8-4
Respiration	8-4
Temperature	8-4
DOX SpO ₂ Module.....	8-5
Main Board	8-5
Power Module	8-6
Fuse Replacement	8-6
AC Power Components.....	8-6

Section 9 - Drawings and Schematics

List of Drawings.....	9-1
Assembly BOMs and Drawings.....	9-1
PCB Drawings and Schematics.....	9-1
Final Assembly.....	9-2
8100E (Without Printer).....	9-2
8100EP (With Printer).....	9-2
8100E1 (With CO ₂).....	9-3
8100EP1 (With CO ₂ and Printer).....	9-3
Main Monitor Assembly	9-4
Main Monitor with CO ₂ Assembly.....	9-5
Chassis Assemblies	9-6
Bottom Chassis Assembly.....	9-6
Power Supply with Brackets.....	9-7
Main Chassis Assembly	9-7
NIBP Chassis Assembly.....	9-8
CO ₂ Internal Module Assembly	9-9
CO ₂ External Module Assembly.....	9-10
Display Chassis Assembly	9-11
Assembly Patient Connectors	9-11
Shielded Analog Board Assembly	9-12
Printer.....	9-12

Appendix A - CO₂ Service

Service Windows.....	A-1
Theory of Operations.....	A-2
Capnometer Module (CO ₂).....	A-2
Block Diagram	A-3
Preventative Maintenance.....	A-4
Maintenance Schedule	A-4
CO ₂ Absorber Verification	A-4
Gas Flow/CO ₂ Verification.....	A-5
Testing Checklist	A-6
CO ₂ Calibration	A-7
Tools Needed	A-7
Before You Begin	A-7
Procedure.....	A-8
Disassembly	A-10
Disconnect the Battery	A-10
Check/Replace the CO ₂ Absorber.....	A-11
Replace the External CO ₂ Module	A-12
Replace the Internal CO ₂ Module.....	A-12
Troubleshooting.....	A-13
Verification Checklist.....	A-14

Warranty

Workmanship & Materials

Criticare Systems, Inc. (CSI) warranties new equipment to be free from defects in workmanship and materials for a period of two (2) years from date of shipment under normal use and service. The following exceptions apply to this statement and the warranty period as indicated:

Internal Batteries: one (1) year
O2 Cells and CO2 Absorbers: six (6) months
940 Series Multi-Site and Y style SpO2 sensors: six (6) months

CSI's obligation under this warranty is limited to repairing or replacing, at CSI's option, any part which upon CSI's examination proves defective.

EXCEPT AS DESCRIBED IN THE PARAGRAPH ABOVE, CSI MAKES NO WARRANTIES, EXPRESS OR IMPLIED, INCLUDING ANY WARRANTY OF MERCHANTABILITY OR FITNESS FOR A PARTICULAR PURPOSE.

Exemptions

CSI's obligation or liability under this warranty does not include any transportation or other charges or liability for direct, indirect or consequential damages or delay resulting from the improper use or application of the product or the substitution upon it of parts or accessories not approved by CSI or repair by anyone other than a CSI authorized representative.

This warranty shall not extend to any instrument which has been subjected to misuse, negligence or accident; any instrument from which CSI's original serial number tag or product identification markings have been altered or removed; or any product of any other manufacturer.

Safety, Reliability & Performance

Criticare Systems, Inc., is not responsible for the effects on safety, reliability and performance of the 8100E Series Patient Monitor if: assembly operations, extensions, readjustments, modifications or repairs are carried out by persons other than those authorized by Criticare Systems, Inc., or

the 8100E Series Patient Monitor is not used in accordance with the instructions for use, or

the electrical installation of the relevant room does not comply with NFPA 70: National Electric Code or NFPA 99: Standard for Health Care Facilities (Outside the United States, the relevant room must comply with all electrical installation regulations mandated by the local and regional bodies of government).

In Case of Emergency Contact



CRITICARE SYSTEMS, INC.
20925 Crossroads Circle
Waukesha, WI 53186
USA

Telephone: (262) 798-8282
Tech Support: (800) 458-2697
Orders: (800) 458-4615
Fax: (262) 798-8290

Internet: www.csiusa.com

Service Return Policy

Return Procedure

In the event that it becomes necessary to return a unit to Criticare Systems, Inc., the following procedure should be followed:

Obtain return authorization. Contact the CSI Service Department at 800-458-2697 to obtain a Customer Service Authorization (CSA) number. (Outside the US, call 001-262-798-8282.) The CSA number must appear on the outside of the shipping container. Return shipments will not be accepted if the CSA number is not clearly visible. Please provide the model number, serial number, and a brief description of the reason for return.

Freight policy. The customer is responsible for freight charges when equipment is shipped to CSI for service (this includes customs charges).

Loaner service. In the U.S. If it is necessary to provide a loaner unit to any U.S. customer, CSI will ship the unit within one (1) working day, if available, by secure transport means.

For units under warranty, a loaner unit (if required) will be made available upon request.

For units out of warranty, in the event of a loaner unit being required after the product warranty has expired and no extended service contract is in place, a charge will be applied to the customer's account.

Loaner units must be returned to CSI at the customer's expense within one (1) week after receipt of the repaired goods. If the unit is not returned to CSI within that time, the customer will be invoiced for the full purchase price of the equipment.

Outside the U.S. No loaners are available from CSI internationally. Contact your local CSI representative.

EC Declaration of Conformity

nGenuity 8100E Series Patient Monitor

To view the Declaration of Conformity, visit the Criticare website at www.csiusa.com. A copy of the Declaration can also be faxed. Contact Criticare's customer service department at (262) 798-8282 to obtain a faxed copy of the Declaration.

Representative in the European Union

Criticare Systems Limited
c/o Wright Hassall
9 Clarendon Place
Leamington Spa
Warwickshire
CV 32 5QP – United Kingdom

T: 0044 (0) 1926 886688

F: 0044 (0) 1926 885588

For the Attention of: Ref. 45 (or) Mr L. A. Heizler

Section 1 — Introduction

Description

The nGenuity 8100E Series monitor interprets and displays real time physiological data including waveforms and numerical data. The monitor is designed for multi-parameter measurements, including ECG, NIBP, SpO₂, temperature, and respiration. Optional CO₂ monitoring is also available. For all these vital parameters, the 8100E Series monitor has limit alarms and alerts. The monitor also prints strip chart recordings and stores tabular trends for review.

Intended Use

The 8100E Series monitor is intended to monitor physiological parameters of patients within clinical care settings. It is intended that the user is a professional health care provider. Physiological data, system alarms, and patient data analysis are available to the care provider from the monitor.

The user is responsible for the interpretation of the monitored data that is made available. Physiological data should be reviewed by a qualified clinical personnel prior to any medical intervention.

The monitor is designed to be used with only one patient at a time. The monitor (including accessories) is capable of monitoring a full range of patients from neonate to adult.

nGenuity 8100E Series Options

The nGenuity 8100E Series monitor comes standard with 5-Lead ECG, ComfortCuff™ NIBP, DOX™ SpO₂, and one temperature channel for monitoring. Options include internal printer and CO₂ monitoring. A color TFT screen with a six waveform display is standard on all nGenuity 8100E Series models.

The nGenuity 8100E Series monitor is also available with ST and Arrhythmia analysis as an option.

<u>Catalog Number</u>	<u>Printer</u>	<u>Additional Features</u>
8100E	No	Standard
8100E-ST	No	ST Arrhythmia
8100E1	No	CO ₂
8100E1-ST	No	CO ₂ , ST Arrhythmia
8100EP	Yes	Standard
8100EP-ST	Yes	ST Arrhythmia
8100EP1	Yes	CO ₂
8100EP1-ST	Yes	CO ₂ , Arrhythmia

Pulse Oximetry Measurement (SpO₂)

The monitor uses Digital Oximetry (DOX) technology to measure blood oxygen saturation (SpO₂).

Definition Hemoglobin exists in the blood in several forms:

- Oxygenated (Oxyhemoglobin)
- Reduced (Deoxyhemoglobin)
- Dyshemoglobins (carboxyhemoglobin and methemoglobin.)

In the monitor, SpO₂ (pulse arterial oxygen saturation) is the ratio of oxygenated hemoglobin to the sum of oxygenated hemoglobin plus hemoglobin which is available for binding to oxygen, as expressed in the following formula:

$$\text{percent oxygen saturation} = \frac{\text{oxyhemoglobin}}{\text{oxyhemoglobin} + \text{deoxyhemoglobin}} \times 100$$

Dyshemoglobins, such as carboxyhemoglobin and methemoglobin, are not directly measured and therefore are not factored into the measurement.

DOX™ Digital Oximetry

The monitor does not use analog circuitry for signal processing. Digital signal processing in the microprocessor results in lower noise from circuitry components, resulting in a cleaner signal and better performance under low perfusion conditions. There is also improved rejection of noise from the patient and environment, due to the availability of the “true,” unfiltered sensor signal for digital signal processing.

Method The digital pulse oximeter measures oxygen saturation and pulse rate using the principles of spectrophotometry and plethysmography. The sensor is completely non-invasive, and there is no heat source that could burn the patient.

The pulse oximeter sensor contains two types of LEDs. Each type emits a specific wavelength of light. Since oxygenated hemoglobin and deoxygenated hemoglobin absorb light selectively and predictably, the amounts of these two compounds can be determined by measuring the intensity of each wavelength that passes through the measuring site.

The light from the LEDs shines into a pulsating vascular bed. A photodetector located opposite or alongside the LEDs measures the intensity of each wavelength transmitted through the monitoring site. The light intensity is converted to an electrical signal, which is input to the monitor. The effects of skin pigmentation, venous blood, and other tissue constituents are eliminated by separating out the pulsating absorption data.

SpO₂ is calculated with every pulse and averaged with the results from previous pulses to arrive at the current numeric display value. The display is updated at least once per second with the numeric values that were calculated during the intervening period.

The plethysmographic pulse wave is not auto-gained. The amplitude display of the plethysmographic pulse wave is proportional to the pulse volume changes occurring in the tissue illuminated by the SpO₂ sensor.

SpO₂ Clinical Testing and Accuracy

All Criticare oximeters (DOX™ compatible) have SpO₂ calibration tables which were originally generated by monitoring desaturated human patients or volunteers and matching their displayed SpO₂ value to the value determined by sampling arterial blood and measuring functional SaO₂ with a clinical laboratory grade multi wavelength optical oximeter (i.e. CO-oximeter). The final SpO₂ calibration curve was then generated based upon numerous patients' data over the range of 40 to 99% SaO₂. All accepted data were taken from patients with dyshemoglobin (i.e., carboxyhemoglobin, methemoglobin) concentrations near zero.

This oximeter is a two-wavelength device, which is calibrated to measure functional SpO₂ only when dyshemoglobin concentrations are near zero. The accuracy specifications of this device will not be met with high concentrations of dyshemoglobins. Significant concentrations of carboxyhemoglobin results in a higher displayed SpO₂ value than is actually present in the patient.

SpO₂ clinical accuracy validation to CO-oximeter SaO₂ readings was performed for this sensor using a DOX-compatible monitor.

The personal demographics of the study participants for the SpO₂ clinical accuracy validation include a mix of adult males and females from 18–45 years of age. All were healthy during the course of the study. Physical characteristics and skin tone were by chance with a mix from slight to stout and light to dark.

Heart Rate

The heart rate is determined primarily from the ECG waveform data. A beat detection algorithm is used to identify QRS beats.

The monitor has a user selectable smart heart rate function. It automatically uses alternate sources to determine heart rate, if the primary source becomes unmeasurable. The plethysmograph (SpO₂ waveform) is used if the ECG heart rate is unavailable. In the absence of SpO₂ and ECG data, the NIBP oscillometric data is the final default source for a heart rate measurement.

Response times for the ECG heart rate meter change from 80 BPM to 40 BPM and from 80 BPM to 120 BPM is less than or equal to 10 seconds. The alarm for tachycardia is less than or equal to 10 seconds per EC-13.

The pulse rate accuracy for SpO₂ is the root-mean-square (rms) difference between paired pulse rate data recorded with the pulse oximeter and a reference method.

NOTE: The accuracy of the heart rate depends upon the source. The range of the measurable NIBP based heart rate does not extend as far as the range available in other modules used by the smart heart rate feature.

NOTE: The NIBP based heart rate is not a continuous measurement and is only current during an NIBP measurement.

ECG Measurement

The electrocardiogram (ECG or EKG) records the changing potential generated by electrical activity of the heart.

Method To obtain an overall view of the heart's electrical activity, three or five electrodes attached to lead wires detect electrical impulses from the patient's heart to the skin. The monitor calculates the difference in electrical force between two electrode sites. Electrode polarity (positive, negative, or ground) depends on the cable receptacle the lead wire is attached to and the lead selected on the monitor screen.

The ECG design uses the standard (conventional bipolar limb leads) leads I, II, III using 3-lead or 5-lead cable accessory. With the 5-Lead cable accessory, leads aVR, aVL, aVF, and V lead may also be viewed.

The monitor has user selectable automatic lead switching capability when using the 5-lead settings. If a lead becomes detached or is unmeasurable, the monitor can automatically display an alternate lead view using the remaining leads.

Stability of Accuracy The monitor is equipped with pacemaker detection and user selectable pacer rejection. There are no known safety hazards due to the operation of a cardiac pacemaker or other electrical stimulators when used with this vital signs monitor.

The accuracy of the monitor is not affected by arrhythmia or other physiological conditions where the electrocardiogram amplitude and heart rate are within the detectable limits specified for the monitor. The monitor has user selectable signal filtering in the 60 Hz and 50 Hz bands that reduce electrical interference from the AC (mains) power sources. User selectable filters are also available.

The accuracy of the ECG analog output bandwidth is equal to the frequency response specified in the ECG specifications. The variable gain control is x200, x400, or x800 (according to the ECG Sensitivity setting). The propagation delay is 1000 milliseconds.

The accuracy of the synchronizing pulse amplitude is equal to 500 times that of leadview II. The pulse shape and duration match those of leadview II. The output impedance is 1000 ohms and propagation delay is less than 6.6 milliseconds.

Pacemaker Pulse Rejection With the pacemaker detector turned *ON* in the 8100E(P) Series, the system detects and rejects pacemaker pulses ranging from ± 2 to ± 700 mV amplitude and 0.1 to 2.0 ms duration. Heart rates properly display over this range of pacemaker operation. Pacer pulse markers are present if pace detect is on and appear in the ECG analog output as narrow positive spikes at the point of pace detection.

CAUTION

- Ambient noise sources may induce artifactual triggers of the pacemaker pulse detector and display.

Respiration

Respiration is measured via the ECG electrodes. The ECG uses the impedance measurement based off of lead II.

When determining respiration from the ECG, the monitor measures patient respiration by impedance pneumography. As the patient's chest changes size and shape during inspiration and expiration, the resistance between two chest (or abdomen) ECG electrodes changes. Respiration rate is calculated from this change in resistance.

The user may select ECG which uses the impedance measurement based off the lead I or the CO₂ respiration that is based off the capnogram. There is also a selectable smart respiration function that can automatically switch sources, if there is an interruption of waveform data. The CO₂ data is the primary source for the smart respiration function and it defaults to the CO₂ source if it is available.

Non-Invasive Blood Pressure (NIBP)

The monitor uses ComfortCuff technology to determine non-invasive blood pressure by means of oscillometry. The oscillometric method detects volume displacements within the artery and senses pressure variations within the blood pressure cuff during inflation. The monitor uses cuffs ranging in size from neonate cuffs to thigh cuffs.

Comfort Cuff™ Technology

ComfortCuff technology measures NIBP while the cuff inflates. Consequently, a measurement is obtained more quickly and with less discomfort than with monitors, which measure NIBP during cuff deflation.

Description of NIBP Measurement

The NIBP cuff begins to inflate at the beginning of the NIBP measurement cycle. As the cuff pressure approaches the diastolic pressure of the patient, the cuff pressure waveform begins to indicate the pulse waveform. The cuff pressure at this point is equal to the patient's diastolic pressure, which is stored by the monitor.

As cuff pressure continues to increase, the pulse waveform (as measured from BP cuff pressure fluctuation) becomes stronger, reaching its maximum at the patient's mean arterial pressure (i.e., when cuff pressure = mean BP). The monitor stores this value as mean pressure.

As cuff pressure increases further, it approaches the patient's systolic pressure, and the cuffs pulse waveform decreases in amplitude. The cuff pulse waveform disappears at the point where cuff pressure is equal to the patient's systolic pressure.

When the monitor determines that the cuff waveform has decreased to zero amplitude, it stores the cuff pressure value as the systolic pressure, and releases the pressure from the cuff. This typically occurs at about 10 mmHg over the patient's systolic pressure. The cuff then rapidly deflates.

Dynamic Measurement Ranges

	Systolic (mmHg)	Diastolic (mmHg)	MAP (mmHg)
Adult	50-280	30-225	35-245
Pediatric	50-280	30-225	35-245
Neonate	50-135	20-100	30-120

NIBP Clinical Testing and Accuracy

This device was clinically tested per the requirements of EN 1060 and AAMI SP-10. The NIBP module as installed in the 8100E Series monitor has been tested to meet the performance specifications listed in this manual.

Cuff Inflation and Pressure Protection

The maximum cuff inflation rate is 15 mmHg/sec. The software limits inflation to 300 mmHg adult, 300 mmHg pediatric, or 150 neonate. A secondary circuit limits maximum possible cuff pressure to 330 mmHg in adult/pediatric mode and 165 mmHg in neonatal mode. Cuff pressure is allowed to remain above 30 mmHg for a maximum of two minutes.

The monitor automatically deflates the cuff if the time limit is violated. The monitor contains hardware protection for overpressure conditions, pressure transducer failures, or microprocessor and pump control circuit failures.

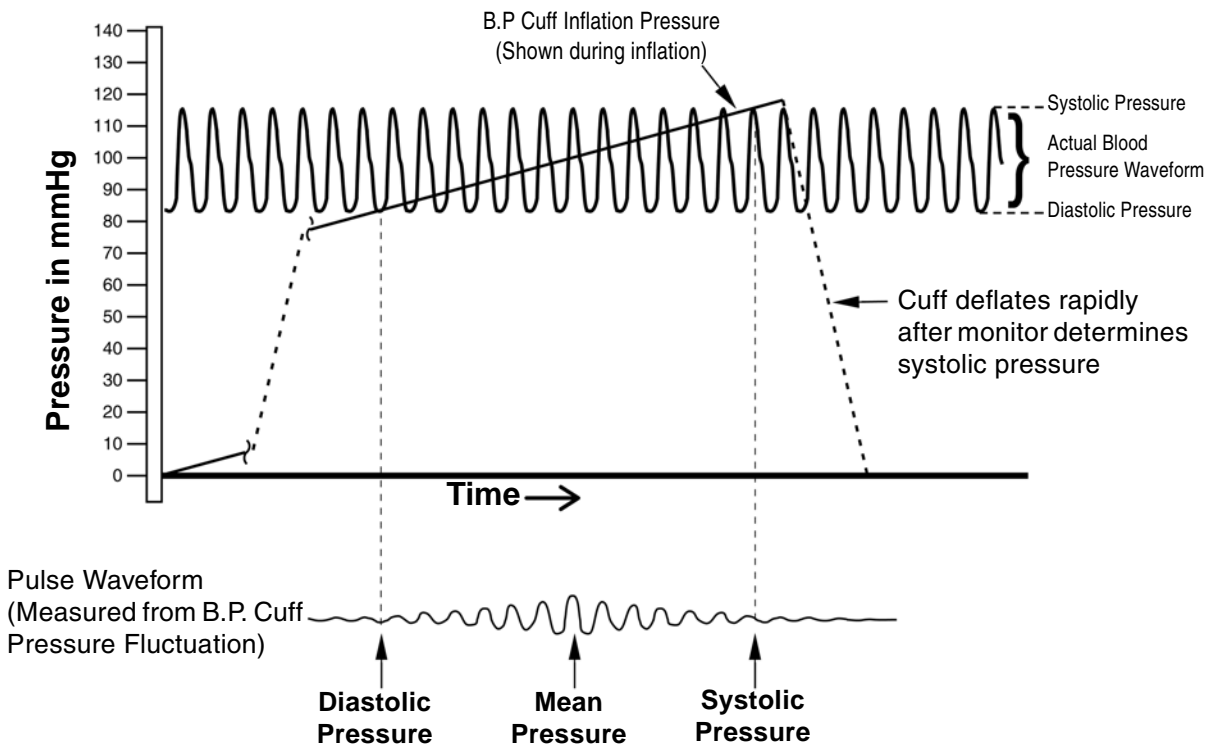

Figure 1-1: NIBP Cuff Pressure and Pulse over Time

Capnography (Measurement of CO₂)

The 8100E Series monitor uses the sidestream method of measuring CO₂. Gas is aspirated through a nasal cannula or a ventilation circuit adapter. The gas sample enters from a sampling tube into a water trap, which removes water vapor and particulate matter from the gas sample. The gas then enters the CO₂ detector where it is analyzed.

The monitor measures CO₂ concentrations and displays them in a continuous waveform. The monitor also detects end-tidal and fraction Inspired CO₂ levels, displaying them numerically. End-tidal CO₂ (ETCO₂) is defined as the maximum CO₂ concentration at the end of expiration. The monitor measures and displays this numerical value of CO₂ concentration. The ETCO₂ value is updated continuously with each breath cycle. The amount of CO₂ in the gas mixture inhaled in by the patient is the fractional Inspired CO₂ (FICO₂).

Method of Measurement

The monitor measures CO₂ using the principles of infrared absorption spectrometry. An unknown concentration of gas (CO₂) is calculated by comparing its absorption of infrared light to that of a known standard. The absorption of light is directly related to the concentration of gas. As infrared light passes through the sample gas chamber, the light transmitted is converted to a voltage signal. The monitor converts the voltage to CO₂ concentration and expresses it as mmHg, percent (%), kPa (user selectable), or Torr.

Infrared analysis of the gas samples is done using Beer's Law.

The formula for Beer's Law:

$$I = I_0 e^{-\epsilon(\lambda)cd}$$

- I*** Infrared value of measured sample.
- I*₀** Infrared value of light source.
- e*** Exponential function.
- ε*(*λ*)** Extinction coefficient.
- c*** Concentration of the gas sample
- d*** Distance measured through the sample

The Beer's Law calculation is performed by the monitor's software.

Conditions of Use The 8100E Series monitor has been calibrated with dry NIST-traceable calibration gases at room temperature and pressure (~ 21°C, 740mmHg). Given the small effect of water vapor upon the CO₂ measurement and the unit's built-in temperature and pressure measurements and compensations, this monitor's method of gas analysis is best described as ATPS (Ambient Temperature and Pressure, Saturated; 21°C 750mmHg, 100% Humidity Saturated).

The monitor is suitable for sustained pressure (breathing circuit) monitoring environments and has been tested per clause 51.101 (Measurement Accuracy) of EN 21647: 2004.

Stability of Accuracy The monitor has an internal barometer and thermistor that allow compensation for changes over a range of temperature and atmospheric pressures. The monitor complies with EN 21647 standards for cyclical pressure and testing found negligible drift of accuracy. The module as installed in the 8100E Series monitor has been clinically tested for performance with a variety of patients.

N₂O Compensation The monitor has a manual N₂O compensation feature for a fixed N₂O value is 60%. The user may select N₂O compensation when 40-80% N₂O is in use.

Temperature Measurement

Body temperature is measured by the monitor using a thermistor (temperature sensing elements in the temperature probe). The thermistor can sense change in body temperature by changing electrical resistance.

- Unusual, fast artificial variations in temperature readings may occur with accompanying applications of an electrocautery system.
- Electrical leakage current of the cable when used with the monitor and sensor comply with IEC 601-1/EN 60601-1

The monitor is compatible with any YSI-400 or YSI-700 series temperature probe.

Specifications

ECG

Connectors:	3 or 5 Lead, Standard AAMI
Lead Selection:	3-Lead; I, II, III 5-Lead; I, II, III, aVR, aVL, aVF, V
Gain Selection:	0.5, 1.0, 2.0, 4.0
ECG Sensitivity	Low 0.5, Medium 1.0, High 2.0, Auto
Frequency Response:	Diagnostic; 0.05 - 100 Hz (-3db) Monitor; 0.50 - 40 Hz (-3db)
Electrosurgery Protection:	Yes
HF Equipment Protection:	Yes
Defibrillator Protection:	Yes
Pacer Detection/Rejection:	Yes

Heart Rate

Source:	Smart Switching; ECG(primary), Pleth, NIBP
Range:	20-300 bpm (ECG, Pleth) 30-240 bpm (NIBP)
Accuracy:	± 1 bpm or 1% ECG, whichever is greater (±3 bpm maximum)
Pulse Tone:	Selectable, On/Off

Respiration

Source:	ECG, CO ₂ (primary)
Rate Range:	6 to 150 breaths/minute (ECG) 0 to 120 breaths/minute (CO ₂)
Resolution:	1 breath/minute
Accuracy:	±1% or ±1 breath/minute, whichever is greater

SpO₂

Range:	1-99%
Resolution:	1%
Accuracy:	70-99% range; ± 2%; 50-69% range; ± 3% <50%; unspecified; Statistical, represents one st. dev. (~66%) of clinical samples.
Indications	Plethysmograph, Numerical, Audible (pulse tone pitch varies with SpO ₂)
Method:	Dual wavelength LED
Modes:	Adult/Pediatric/Neonate
Operation:	Continuous Use
Sensor Wavelength:	660nm/905nm
Sensor Power:	<80mW

NIBP

Technique:	Oscillometric measure upon inflation
Measurement Time:	<40 seconds average; standard adult cuff
Automatic Measurement Cycles:	2, 3, 5, 10, 15, 30 min; 1, 2, 4 hrs
Inflation Pressure Range:	Adult; 0 to 300 mmHg Pediatric; 0 to 300 mmHg Neonatal; 0 to 150 mmHg
Resolution:	1 mmHg
Transducer Accuracy:	± 2 mmHg or 2% of reading, whichever is greater
STAT mode:	5 min of consecutive readings

Capnometry (CO₂)

Units:	mmHg; Percent; kPa; Torr
Display:	Inspired CO ₂ , Expired CO ₂ (End-Tidal) Numerical values, capnogram, and breath by breath ETCO ₂ bar graph.
Method:	Non-dispersive Infrared, Auto-calibrating
Calibration:	Auto-calibrating, Manual Calibration
Waveform Scale:	Selectable, percent only 0 to 3.13, 6.25, 12.5 or 25%
Range:	0 to 99 mmHg, 0 to 12.5% 0 to 12.5 kPa, 0 to 99 Torr
Resolution:	1 mmHg, 0.1%, 0.1 kPa, 0.1 Torr
Accuracy:	±2 mmHg, ±0.3 vol%, ±0.3 kPa, ±2 Torr @ 200 ml/min & RR ≤ 120 Br/min
N ₂ O:	Manual (On/Off)
Flow Rate:	200 ml/min
Flow Tolerance:	200 ml/min, ±10% (20 ml)
System Response Time:	1.25 seconds @ 200 ml/min using an 8 ft sample line
Rise Time:	170 milliseconds @ 200 ml/min (10-90%)
Delay Time:	1.08 seconds
Time from cold start:	15 sec. (including auto-calibration) to first reading; 1 min. to full accuracy
Pneumatic Sound Pressure:	35 dBa maximum @ 1 meter

Temperature

Channels:	1
Range:	68° - 113°F, 20° - 45°C
Accuracy:	± 0.1°C over entire range
Display Resolution:	± 0.1°C
Probe Type:	YSI-400 or YSI-700

Alarms

Characteristics:	EN 475, Adjustable
Indication:	Audible; Visual
Levels:	High, Medium, Low, Informational
Settings:	User Defaults, Hospital Defaults, Factory Defaults
Alarm Modes:	Adult/Pediatric/Neonate, High and low limit settings for each mode.
Volume:	User Adjustable (1-10)
Silence:	Yes; 2 minutes or permanent

Trend Reports

Types:	Tabular and Graphical
Trend memory:	24 hours
Tabular Intervals:	30 sec., 1, 2, 5, 10, 15, 30 min., 1, 2, 4 hrs., NIBP (user selectable)
Graphical Span:	2, 4, 8, 12, or 24 hours
Data Types:	BPM, HR, SpO ₂ , Temp., Resp., NIBP (Systolic, Diastolic, Mean)

Printer (Optional)

Recorder Type:	Internal thermal line printer
Data Formats:	Single or dual waveform; Tabular
Paper Speed:	12.5 or 25mm/sec continuous. (Snapshot at 50mm/sec)

Controls

Screen:	10.4" active color TFT
Resolution:	640 x 480 pixels
Waveforms:	6, maximum
Waveform Display Gain:	0.5x, 1x, 2x, 4x user selectable
Waveform Sweep Speed:	6.25, 12.5, 25 or 50 mm/sec, selectable
Keys:	9; membrane-activated
Rotary knob:	Push and rotate; 24 steps/turn
Languages:	English, French, German, Portuguese, Spanish, Italian, Russian

System Outputs

Com Ports:	RS 232-compatible; digital DB9 (COM 1); mini-DIN8 (COM 2)
Nurse Call:	Contact switch; audio jack 1/8 inch, 24V @ 100 ma maximum switching
Defibrillation Sync:	BNC connector
Video Port:	Serial VGA Compatible

Mechanical/Electrical

Weight:	13.2 lb; 6 kg (no CO ₂) 14 lb; 6.4kg (with CO ₂)
Size:	11.0" (H) x 13.0" (W) x 10.3" (D) 28.0cm (H) x 33.1 cm (W) x 26.2cm (D)
Mechanical Shock:	No affect when tested to IEC 60068-2-27 standards
Vibration:	No affect when tested to IEC 60068-2-64 standards
Power Requirements:	35W, typical
Voltage:	100 - 240 VAC; 50/60 Hz
Number of Batteries:	1 sealed lead acid batteries
Battery Life:	3 hr, typical w/o CO ₂ ; 2.5 hr, typical w/CO ₂
Recharge time:	4.5 hours













Environmental









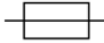

Operating Temperature:	59° - 95°F, 15° - 35°C
Storage Temperature:	23° - 122°F, -5° - 50°C
Operating and Storage Humidity:	15% to 90%; non-condensing
Medical Device:	Class II Equipment (IIb EU)
Electrical Protection:	Class I Equipment
Degree of Protection:	Type CF, Defibrillator-Proof
Protection against ingress:	IPX1
Altitude:	-1,000 - 10,000 feet

All specifications are subject to change without notice.

Specifications related to the ST and Arrhythmia option are found in the Arrhythmia and ST Analysis appendix in the 8100E operator's manual.

Symbols

Symbol	Definition
	Refer to Operator's Manual for Information
	Shock Hazard
	Equipotential Terminal
	European Community Mark
	Electrical Testing Laboratories (ETL) Mark
 	Do not dispose of in municipal waste. Wheeled bin symbol indicates separate collection for electrical and electronic equipment. (WEEE Directive 2002/96/EEC)
	Type CF Equipment, defib proof
IPX1	Identifies the degree of protection against fluid as drip-proof.
	Input/Output port
	Output only port
	Alarm port (Nurse call)
	External display port

Symbol	Definition
	Fuse
	Gas Scavenging
	Air Intake
	Alternating Current (AC)
	Technical Support Phone Number
	Serial Number
	Part Reference Number
	Placement of cuff over the brachial artery. (Blood Pressure Cuff)
	Single use device only. Do not reuse.
	Recyclable cardboard/paper packaging.

Safety

Definitions Definitions for Warning and Caution symbols:



Designates a possible dangerous situation. Non-observance may lead to death or the most severe injuries.



Designates a possible dangerous situation. Non-observance may lead to minor injuries or damage to the product.

Warnings



- Read this manual entirely before attempting clinical use of the monitor.
- Inspect For Damage! User should inspect the system for signs of damage. Do not use the system if failure is evident or suspected.
- Possible explosion hazard! Do not use the monitor in the presence of gas mixtures which may be flammable.
- Do not use this device in conjunction with flammable anesthetics such as cyclopropane and ether. The monitor can sample from pure oxygen environments, but the monitor itself should never be placed inside an oxygen rich environment, such as an oxygen tent or gas containment apparatus. When not in operation, this device is not intended to be connected to any pressurized source containing an enriched oxygen environment.
- All cords must have hospital grade plugs and be plugged into hospital grade outlets. (The electrical installation of the relevant room must comply with NFPA 70: National Electric Code or NFPA 99: Standard for Health Care Facilities. Outside the United States, the relevant room must comply with all electrical installation regulations mandated by the local and regional bodies of government).
- Cables, cords, and leadwires may present a risk of entanglement or strangulation! Verify safe and proper positioning of these items after patient application.
- Leakage currents may increase if other equipment is interconnected to the patient. The increased leakage currents may present a hazard to the patient.

⚠ WARNING ⚠

- High Frequency (HF) surgical equipment may affect ECG operation. The ECG waveform will return to normal momentarily after the HF source is removed. Ensure that electrodes and sensors are not placed near the HF source.
- Unapproved modifications to the monitor may cause unexpected results and present a hazard to the patient. Unapproved use of the accessories can also result present a hazard to the patient or affect monitor performance.
- Do not re-use accessories labeled as single use. Risk of patient contamination may occur.
- Improper disposal of batteries may result in explosion, leakage, or personal injury. Do not open batteries. Do not dispose of batteries in a fire. Follow all local regulations concerning the disposal of spent Lead-acid batteries or contact Criticare for assistance.
- Risk of electrical shock! Do not remove cover. Refer servicing to qualified personnel.
- U.S. Federal law restricts this device to sale by or on the order of a physician.

Cautions**⚠ CAUTION ⚠**

- Use the monitor only with recommended accessories! Use of unapproved accessories may cause inaccurate readings.
- Equipment accuracy may be affected at extreme temperatures.
- Do not store equipment at extreme temperature. Temperatures exceeding specified storage temperatures could damage the system.
- A possible explosion hazard exists! Do not use the monitor in the presence of flammable anesthetics.
- Do not press on the keys with surgical instruments or other tools. Sharp or hard objects could damage the keys. Use only your fingertips to press on the keys.
- Do not allow the conductive parts of the patient electrodes to contact other conductive parts, including ground (earth).
- Changes or modifications not expressly approved by Criticare Systems, Inc., may void the user's authority to operate the equipment and may also void the warranty.
- Always monitor patients with a pacemaker very closely, since the 8100E may count at the pacemaker rate during cardiac arrest or some arrhythmias.

Leakage Current The monitor complies with leakage current limits required by medical safety standards for patient-connected devices. A hazard caused by the summation of leakage currents is possible, when several pieces of equipment are interconnected.

Connecting any external equipment to signal input, signal output, or other connectors forms a system and this new system must comply with the requirements of IEC 60601-1-1. If in doubt, contact qualified technician or local representative.

Voltage Fluctuations When operated in the line voltage range specified in this manual any fluctuation will have a negligible effect. Very low line voltage will cause the monitor to revert to battery power. Very high line voltage may cause damage to the charger circuits. The monitor is designed with circuitry that turns the unit off before spurious readings can be caused by a low battery condition.

Equipotential Ground Health care providers and patients are subject to dangerous, uncontrollable compensating currents for electrical equipment. These currents are due to the potential differences between connected equipment and touchable conducting parts as found in medical rooms.

The safety solution to the problem is accomplished with consistent equipotential bonding. The monitor is fitted with a connecting lead made up with angled sockets to the equipotential bonding network in medical rooms.

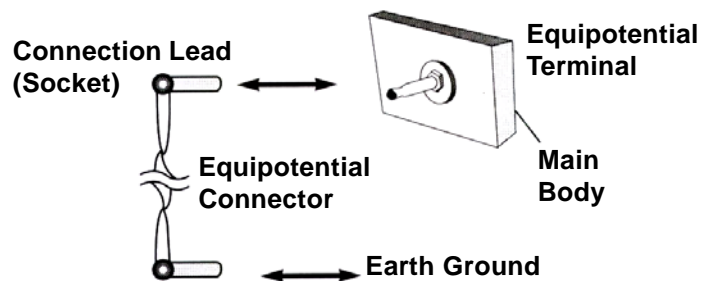

Software Error Related Hazard Mediation Criticare Systems, Inc., has quality control practices and procedures in place to review potential hazards as they relate to software. The monitor is Year 2000 Compliant and utilizes a 4 digit year for all date, time, and leap year calculations.

Potential Interference This device has been successfully tested to IEC 601-1-2 specified levels for emissions of and resistance to electromagnetic energy fields. External disturbances which exceed these levels may cause operational issues with this device. Other devices which are sensitive to a lower level of emissions than those allowed by IEC 601-1-2 may experience operational issues when used in proximity to this device.

MAGNETIC FIELDS

Use of the monitor in an MRI environment may interfere with MRI image quality. Use of MRI may interfere with the monitor.

The 8100E Series patient monitor is not intended for use in MRI environments.

RADIO FREQUENCY INTERFERENCE

The monitor conforms with IEC 1000-4-3 for radio frequency interference, and will operate with negligible adverse effects.

CONDUCTED TRANSIENTS

The monitor conforms with IEC 61000-4-4, and IEC 61000-4-5 for conducted transients, and will operate with negligible adverse effects.

X-RAY

The monitor will operate with negligible adverse effects in an X-ray environment. However, the monitor should not be placed directly in the X-ray beam, which could damage the internal electronics of the monitor.

OTHER INTERFERENCE

There is a negligible adverse effect to the monitor from electrocautery and electrosurgery, infrared energy, and defibrillation.

- Biocompatibility** All patient-contact or user-contact materials in this monitor and its accessories have passed ISO 10993-5, -10, & -11 biocompatibility tests or have been in use in clinical environments in large numbers over an extended period of time predating these standards.
- Latex Content** All Criticare Systems, Inc., products, including patient monitors and accessories, are free from latex in any location that may result in patient contact.
- DEHP Content** All Criticare Systems, Inc., products currently shipping are free of DBP and DEHP in any areas that would be intended for patient contact with blood, mucous membranes, or continuous skin/tissue contact.

Section 2 — Service Windows

Service Mode Window The monitor has a *Service Mode* window that is accessible through the *CONFIG* window of the monitor.

⚠ WARNING ⚠

- Never service a monitor while it is attached to a patient.
- Never enter the service menu while monitoring a patient.

Service Mode Window To access the *Service Mode* located in the *CONFIG* window:

1. Press the ON/OFF button on the front panel to turn on the power to the monitor.
2. Rotate the menu knob to highlight *CONFIG* in the main menu and press the knob once to select it. The *CONFIG* window appears.

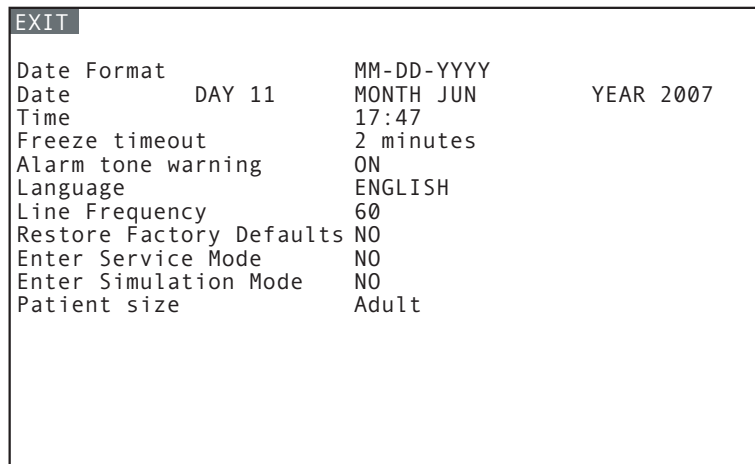

Figure 2-1: CONFIG (Configuration) Window

3. Rotate the menu knob to highlight *Enter Service Mode* and press to select. The value *NO* is highlighted.

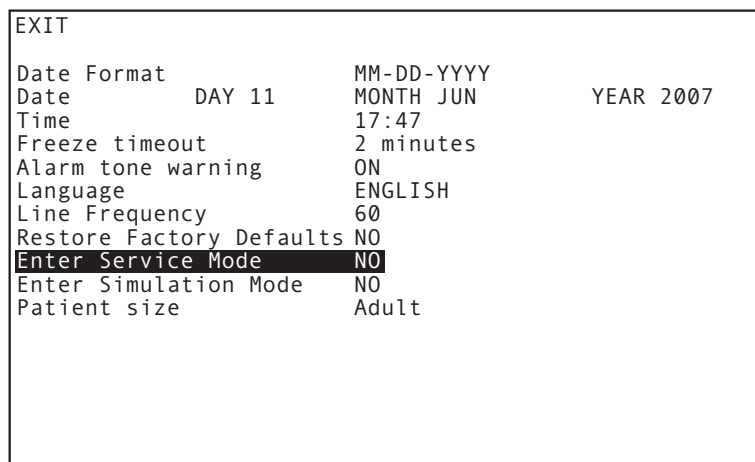

Figure 2-2: Enter Service Mode Highlighted

4. Rotate the menu knob to highlight *YES* and press to select. The *Enter Service Mode* dialog box appears.

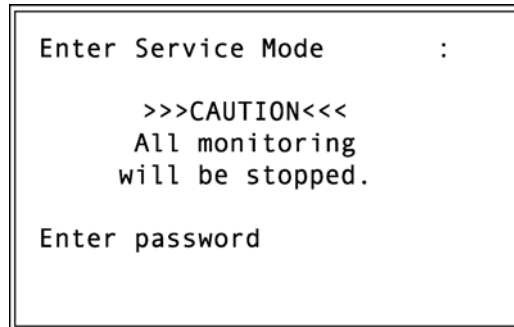

Figure 2-3: Password Window for Service Mode

5. To enter the service mode enter the password PIA418 by doing the following:
 - Rotate the menu knob to select a character.
 - Press the menu knob to enter each character.
 - If a mistake is made, advance to the end of the password and start over.

When you enter the correct password, the *Service Mode* window appears. (See the next step.)

If you entered an invalid password, the window below appears. Check the validity or spelling of the password you entered and repeat the password entry.



Figure 2-4: Invalid Password Window

6. When you enter a valid password the *Service Mode* window appears:

```

EXIT
Enter NIBP Service      NO
Software Download      No action taken
Permanent Alarm Silence Enable
ST / Arrhythmia Keycode ----- Invalid Keycode

Current Software Revisions
Main Display Processor  Rev 1.2F
NIBP/CO2/O2 Processor  Rev 6.5C
Vital Signs Processor  Rev 6.2A

Unit Serial Number     11111111
Unit Part Number       93979AXXX
Keycode Base Number    00000000

```

Figure 2-5: Service Mode Window

From this point, you can access all service mode functions and calibrations, set operation values, and perform tests. All the following functions are accessed from the *Service Mode* window shown above:

- NIBP Service Mode
- Processor Software Download
- Permanent Alarm Silence
- Arrhythmia and ST Analysis

NOTE: Monitors with CO₂ monitoring will have additional items in the *Service Mode* window. See “Appendix A – CO₂ Service” for CO₂ service screens.

NOTE: After you perform each service mode function, you must turn off power to the monitor. Press the ON/OFF button on the front panel of the monitor.

NIBP Service Mode From the *Service Mode* window, do the following:

NOTE: To service the NIBP module you need specified equipment. See “Section 6: Service Testing and Calibration” for details.

1. To run a high time or pressure test for adults or infants, or to run an inflate/deflate speed test, with the menu knob highlight *Enter NIBP Service* and press to select. The value *NO* is highlighted.
2. Rotate the menu knob to highlight *YES* and press to select. The *NIBP Service Mode Parameters* window to service NIBP appears.

	RESULT
Run Leak / Adult High Time Test	NO
Run Infant High Time Test	NO
Run Adult High Pressure Test	NO
Run Infant High Pressure Test	NO
Run Infl / Defl Speed Test	NO
<hr/>	
ELAPSED TIME / MAX PRESSURE	0

Figure 2-6: NIBP Service Mode Parameters Window

3. Rotate the menu knob to highlight the test you want to run and press to enter. The test value *NO* is highlighted.
4. Rotate the menu knob to highlight *YES* and press to begin the test. When the test is executing, the following message appears on the bottom of the *NIBP service* window:
Test in progress, select NO to cancel
5. Press the ON/OFF button to exit the *NIBP Service Mode Parameters* window.

NOTE: Pressing the ON/OFF button will turn off the monitor. Press the ON/OFF button again to restart the monitor.

Processor Software Download The *Software Download* parameter in the *Service Mode* window is used to download software for the following processors:

- NIBP/CO₂ Processor
- Vital Signs Processor
- Main Display Processor

From the *Service Mode* window:

1. Rotate the menu knob to *Software Download* and press to select.
2. Rotate the knob to choose the processor you wish to download and press to select. The value *NO* is highlighted.

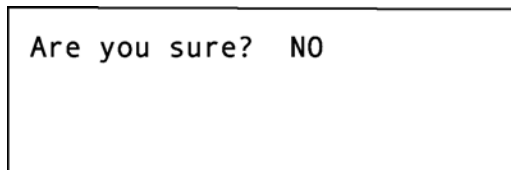

Figure 2-7: Initial Software Download Dialog Box

3. Rotate the menu knob to highlight *YES* and press to select. The following window appears:

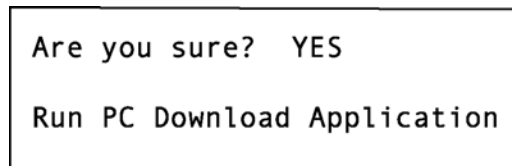

Figure 2-8: Software Download Response Message

If you choose not to select *YES*, allow *NO* to remain selected, and then press the menu knob to return to the *Service Mode* window. The following message then appears next to the *Software Download* parameter:

No action taken

4. Press the ON/OFF button on the front panel of the monitor to turn off the power to the monitor.

Permanent Alarm Silence From the *Service Mode* window:

1. To disable the permanent alarm silence feature, with the menu knob highlight *Permanent Alarm Silence* and press to select. *Enable* is highlighted.
2. Rotate the menu knob to highlight *Disable* and press to select.
3. Press the ON/OFF button on the front panel of the monitor to turn off the power to the monitor.

NOTE: Read about the override capability of the *Permanent Alarm Silence* function over the *Alarm Tone Warning* function in “Alarm Tone Warning” on page 2-8.

 **CAUTION** 

- Before you disable this safety feature, contact your local distributor because the Permanent Alarm Silence tone is required in certain countries.

Arrhythmia and ST Analysis The Arrhythmia and ST Analysis software extension has the capability to measure ST segment deviations and generate arrhythmia alerts for common ventricle arrhythmia conditions.

The arrhythmia and ST features are available through keycode activation on all nGenuity 8100E Series monitors. The feature can be purchased from Criticare Systems, Inc.

NOTE: Unless instructed, DO NOT enter a keycode. In case of accidentally selecting the keycode, simply turn off the monitor without completing the keycode entry. The keycode will not be over written unless you enter the complete keycode.

8100E Series models that do not include the arrhythmia and ST analysis feature will have the message *Invalid Keycode* appearing next to the setting.

Service Settings

Several settings on the *CONFIG* window are password protected. You should not change these functions during use and only biomed technicians or supervisory personnel should adjust the settings. These functions include:

- *Alarm Tone Warning*
- *Line Frequency*
- *Enter Service Mode*
- *Enter Simulation Mode*

To set the functions listed above, do the following:

1. Rotate the menu knob to highlight *CONFIG* in the *Main* menu and then press the knob once to select it. The *CONFIG* window appears.

```

EXIT
Date Format          MM-DD-YYYY
Date                DAY 11    MONTH JUN        YEAR 2007
Time                17:47
Freeze timeout      2 minutes
Alarm tone warning  ON
Language            ENGLISH
Line Frequency      60
Restore Factory Defaults NO
Enter Service Mode  NO
Enter Simulation Mode NO
Patient size        Adult
  
```

Figure 2-9: CONFIG Parameters window

2. Rotate the menu knob to highlight the service function that you want and press to select.

Service Password To enter the service mode enter the password PIA418 by doing the following:

1. Rotate the menu knob to select a character.
2. Press the menu knob to enter each character.
3. If a mistake is made, advance to the end of the password and start over.

Alarm Tone Warning Set the *Alarm Tone Warning* value to *ON* to allow the monitor to produce a low-pitched double beep every 2 minutes after a new alarm activates.

Set the *Alarm Tone Warning* value to *OFF* to allow the monitor to suspend any audible alarm (remain silent) after a new alarm activates. Thus you can silence alarms with a “long” push (held in for 2 seconds) on the monitor’s SILENCE key.

NOTE: As a safeguard measure, the *Permanent Alarm Silence* function (*Service Mode Window*) can override the *Alarm Tone Warning* function. The *Disable* value of the *Permanent Alarm Silence* function can prevent the ability of the *Alarm Tone Warning* function’s *OFF* value to suspend audible alarms. In this case, pushing the Silence button has no effect; the monitor’s full audio alarm would continue. Set this safeguard according to your facility protocols and according to local safety regulations for medical devices.

Override from the <i>Service Mode Window</i> : <i>Permanent Alarm Silence</i>	Configuration Window: Alarm Tone Warning	
	ON	OFF
ENABLE	double beep	always silent
DISABLE	full audio alarms	full audio alarms

Line Frequency In the *CONFIG* menu the frequency which is rejected is either 50 Hz or 60 Hz. Set the frequency to the local AC (mains) power which is 60 Hz in the U.S. and 50 Hz in most of Europe. Contact your local distributor for more information. The password to change the frequency is PIA418.

Simulation Mode Simulation software is only used for demonstrations and not intended for servicing the monitor. The service password is required to activate this demonstration function. The words *SIMULATION MODE* appear in large letters on the monitor screen when in use.

In the sample window shown below, all function parameters are active and reflected in the waveforms and numerical values that could be useful for a demonstration or training session. The screen only displays functions that are available on the unit.

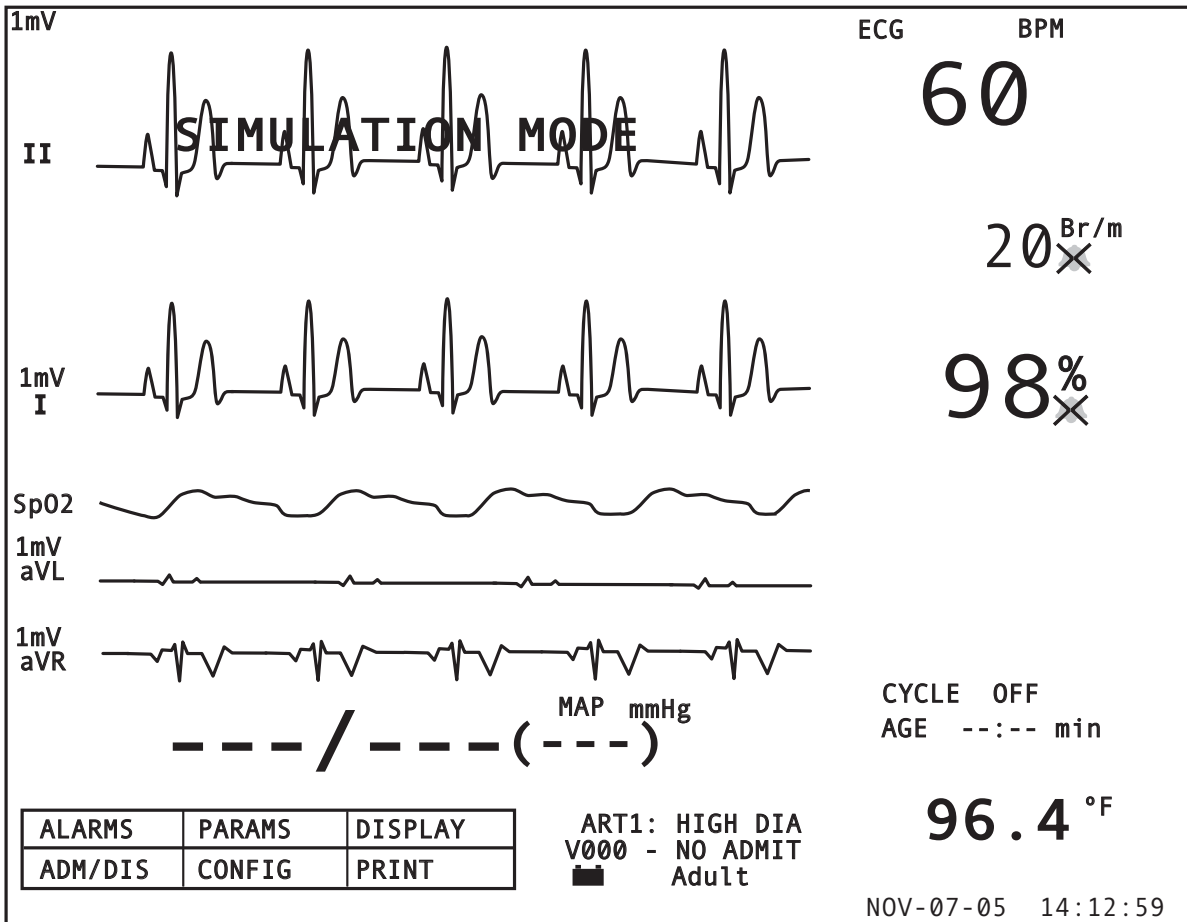

Figure 2-10: Example of the Window in Simulation Mode

NOTE: Simulation Mode can only be exited by pressing the ON/OFF button and turning off the monitor.

NOTE: To exit the menu, navigate to *EXIT* and press *SELECT*.

Custom Profiles

The monitor has a set of default settings that you can configure to the needs of the facility. These default settings are password protected.

Setting Patient Size

The monitor is designed to look at the patient size information selected in the *ADM/DIS* or *ALARMS* windows and determine whether the monitor should use one of the following alarm settings while monitoring:

- Adult
- Pediatric
- Neonatal

When you change the patient size in the *ADM/DIS* window or the *ALARMS* window, the monitor determines which window appears when you select the *ALARMS* window. When the user changes patient size the user effectively changes all the alarm limits for all of the following:

- SpO₂
- ECG
- NIBP
- Temperature
- Respiration
- Maximum NIBP pressure limit.

To enter patient size, do the following:

1. Rotate the menu knob to highlight *ADM/DIS* or *ALARMS* and press to select.
2. Rotate the menu knob to highlight *Update*, select *YES*, and press to select. You can now select the patient data field.
3. Rotate the menu knob to highlight *Patient Size* and press to select.
4. Rotate the menu knob to highlight *Adult*, *Pediatric*, or *Neonate* as required.

Optional: Enter a value for unit label only if you use central station communication.

5. Select *EXIT* to return to the *Main* window.
6. Exit the *ADM/DIS* or *ALARMS* window.

Creating Custom Profiles The default mode you last completed is the default patient size for custom defaults. If you want a different default size mode, change the order in which the monitor saves alarm limits.

In the example below, the first patient size setting created is *NEONATE*. Update the custom default alarm limits for the pediatric and adult modes by repeating the steps in this procedure, two more times, once for *PEDIATRIC* and once for *ADULT* as the patient size setting.

ACCESSING THE DEFAULTS DIALOG BOX

After setting the patient size (e.g., *NEONATE*), start from the main window to access and set the defaults for your facility's custom profile:

1. Press and hold the DEFAULT button on the front panel for approximately two seconds. The *Set Unit Defaults* dialog box appears.

NOTE: If the *Set Unit Defaults* dialog box that prompts you to enter a password did *not* appear, you did not hold the button in properly. In this case, with the menu knob highlight and select *CANCEL* or you could lose the settings you just created.

2. Enter the password LIA608 by doing the following:
 - Rotate the menu knob to select a character.
 - Press the menu knob to enter each character.
 - If you make a mistake, advance to the end of the password and start over.
 - After you press the menu knob for the last character of the password, the monitor indicates acceptance of the password by displaying the *Set Unit Defaults* window.
 - When the *Set Unit Defaults* window displays, both *SELECT* and *CUSTOM DEFAULTS* are highlighted.

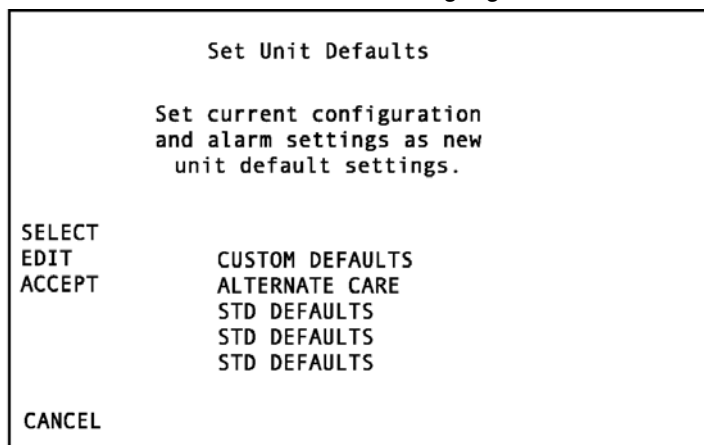

Figure 2-11: Set Profile Before Modifications

ENTERING THE NEW PROFILE TITLE

1. With both *SELECT* and *CUSTOM DEFAULTS* highlighted in the *Set Unit Defaults* window, rotate the menu knob to highlight *EDIT* and press to select.
 - As you rotate the menu knob, *CUSTOM DEFAULTS* remains highlighted.
 - The first letter of *CUSTOM DEFAULTS* is highlighted.
2. Change the label *CUSTOM DEFAULTS* (for example, to the title *FACILITY DEFAULTS*) by doing the following:
 - With the letter *C* highlighted (the first letter of *CUSTOM DEFAULTS*), rotate the menu knob to highlight the letter *F* (the first letter of the example *FACILITY DEFAULTS*) and press to select. The next letter automatically highlights.
 - Continue for the remaining letters of the new title.
 - After completing the last letter in the title (in this example, it would be the letter *S*), press the menu knob until the entire label name highlights. This indicates that the entry is complete but not accepted.

ACCEPTING THE NEW PROFILE TITLE

1. To accept the new label name, rotate the menu knob to highlight *ACCEPT* and press to select. The message *Action Completed* appears.

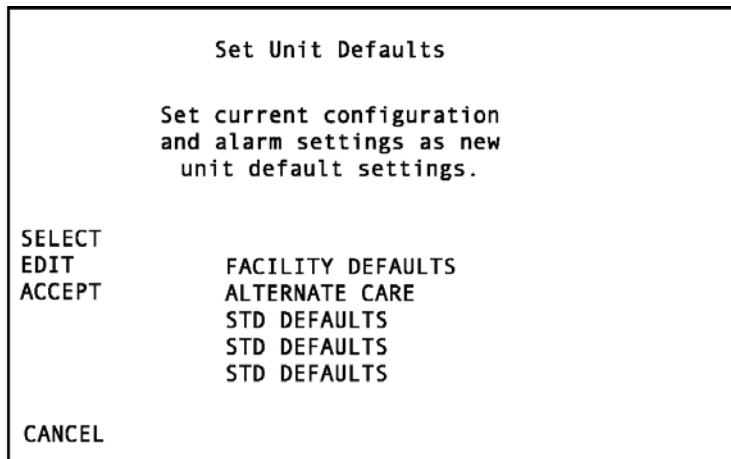

Figure 2-12: Set Profile After Modifications

2. Press the menu knob. Your set of defaults are saved in memory.
3. Press the ON/OFF button on the front panel of the monitor to turn off the power to the monitor.

Section 3 — Theory of Operation

Power Module

The 8100E Series patient monitor employs a universal switching power supply for international use.

In order to monitor the status of the line power, and condition of the battery pack, the internal power supply circuitry drives several status lines available to the main module. The power management/watchdog circuit provides a low battery level detection mechanism and a hardware-based check on software operation (watchdog timer).

Main CPU and System

The microprocessor circuitry handles the Main Board computational functions and provides integrated I/O functions, including timers, I/O pins, serial interfaces, and analog I/O.

CONM Module

The CONM module contains a microprocessor and associated circuitry for NIBP. No electrical connection is made with the patient from the monitor for NIBP. The vital signs parameters are passed to the main module using a serial channel.

Vital Signs Module

The vital signs module is a single printed circuit board with connectors to the Main Board, the ECG input leads, the SPO₂ connector, and the temperature sensor. The vital signs module contains a microprocessor, and associated circuitry for pulse oximetry, temperature, ECG signals, and TTI respiration. ECG signals can be either 3-lead single channel, or 5-lead triple channel. Patient isolation for galvanic contact is required for the temperature and ECG functions. Patient isolation for non-galvanic contact is required for the pulse oximetry sensor. A CAN bus passes the vital signs parameters to the main module.

The main module sends the vital signs module control information and the vital signs module sends the main module waveforms and hardware status. The communication cycle is 20 Hz for the vital signs information from the VS module, twice a second for the status of the VS module, and as needed for the control information from the main module.

Speaker Driver

The speaker drive circuit is a DAC controlling speaker volume and an output pin to control frequency. A software-controlled timer generates a square-wave signal that drives the speaker. Hence, any drive frequency has harmonic components, and generates no “pure tones.” Applicable standards recommend against the use of pure tones in alarm situations to reduce the risk of an individual with a “notch” hearing deficit missing an alarm.

ECG Module

The ECG module monitors from either three-lead or five-lead surface electrode configuration, providing one or three concurrent ECG leadviews, respectively. The ECG module processing includes heart rate, ECG lost, pacer pulse, and leadoff detection. The main software is able to control lead, gain/scale, and filter selection, as well as pacer mode operation. Shielding, both on the PCB and external to it, reduces the impact of ESU noise on signal quality and heart rate calculation. The following issues were important in the design of the ECG module:

- Diagnostic-quality signal bandwidth;
- reliable beat detection and heart rate calculation;
- ESU noise rejection;
- pacemaker pulse detect; and
- artifact rejection

The ECG module uses a differential amplifier to extract surface ECG activity from a pair of electrodes. Input to the amplifier is protected against damage from excessive voltages. Passive filtering reduces high power RF interference from electrosurgical devices. Hardware under software control performs filtering for monitor vs. diagnostic modes, lead selection, lead off detection, and pacer pulse detection. Software performs gain control, notch filtering to remove line frequency interference, pacer artifact handling, noise detection, beat detection, heart rate calculation, and serial (CAN bus) communications.

Impedance Respiration

The TTI respiration circuit uses a transformer to generate a low current, high frequency stimulus through the Lead I electrodes. The resulting voltage variations reflect impedance variations across the thorax, which in turn reflect respiration activity (as well as other phenomena including cardiogenic artifact and motion artifact).

The TTI respiration software performs low pass filtering, high pass filtering, breath detection, and calculates breath rate.

Pulse Oximeter Module (SpO₂)

The pulse oximeter is based upon the principle of dual-wavelength photoplethysmography. Red and infrared LEDs are alternately driven to illuminate some (relatively well-perfused) tissue site, and a photo detector receives either the transmitted or reflected light, resulting in a current flow. This input signal is demultiplexed with sampling in the monitor to separate the red and infrared components. The wavelengths are chosen to permit discrimination of oxygenated and deoxygenated hemoglobin, based on the difference in their absorbance spectra.

In a “pulse” oximeter, a high-passed AC component is extracted from each of the red and infrared signals, and digitally processed to detect the pulsations corresponding to blood flow in the illuminated tissue. The AC and DC components in red and infrared, measured near the time of pulsation, are combined in a relatively simple ratiometric formula (obtained, with many assumptions, by solving Beer’s law equations with empirically derived coefficients) to yield a figure proportional to SpO₂. The pulse rate is also calculated from the pulse intervals detected.

Temperature

The temperature module measures probe resistance and uses an internal data table for looking up temperature conversions. Depending on the user’s selected settings the monitor calculates the temperature in Fahrenheit or Celsius. The conversion value displays on the video screen.

Communications

The monitor provides two patient-isolated external RS-232 serial data ports (TX, RX, and ground):

- The DB-9 COM1 port is configured for compatibility with ASCII printer applications.
- The DIN-8 COM2 port is custom-configured with one pin reserved for analog output.

The main module drives a patient-isolated external analog output. It provides a 0 to 1 v output capable of driving a high-level input, such as a defibrillator or chart recorder.

Printer

The Main Board powers and controls the optional printer module. The Main Board processes error messages from the Printer Board and displays them on the screen. The internal printer module is a Sieko LTP1245-type mechanism.

Block Diagram

The following block diagram aids in tracing communication and data routes within the system. Connection numbers are given to show the relationship between the boards. The diagram is keyed to the theory of operations found on the previous pages.

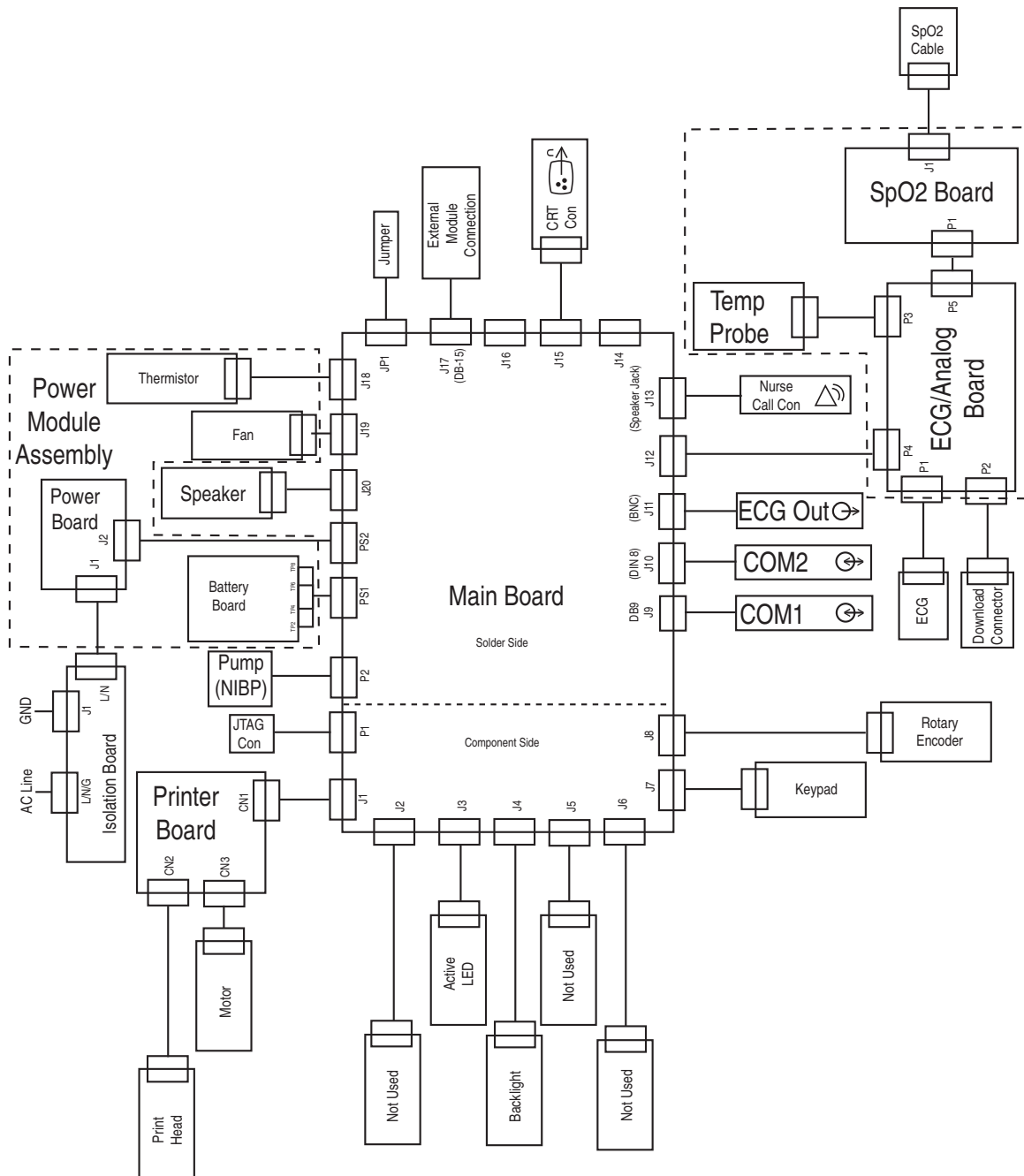

Section 4 — Cleaning and Disinfecting

Cleaning and Disinfecting

WARNING

- Shock Hazard! Before cleaning a monitor and sensor, turn the power off and disconnect the AC power cable.
- Shock Hazard! Never immerse the monitor because the monitor has an internal power source that is active even when the unit is unplugged.

Do not use abrasive cleaners on the monitor or on any sensors or probes. Abrasive cleaners damage the monitor, sensors, and probes.

With the exception of the display screen, wipe clean the exterior surface of the monitor with alcohol. Dry it with a soft, dry cloth. Because paper towels or tissues can scratch the surface of the display, use a cotton cloth to clean the monitor.

Do not use full-strength alcohol on the display screen. Repeated use of strong cleaners damages the screen. Clean the display window by wiping it clean with a soft, lint-free cloth sprayed with common glass cleaner, however, do not spray glass cleaner directly on the display.

Pulse Oximeter Sensors

CAUTION

- Do not immerse any Criticare pulse oximeter sensor connector in any liquid because it damages the connector.

The SpO₂ sensor can be wiped clean with alcohol. Disinfect the SpO₂ sensor by placing the paddles and cable in a 2% glutaraldehyde solution. Only the sensor paddles and cable are placed in the solution.

Blood Pressure Cuffs

You can clean the reusable blood pressure cuff by wiping it with a damp cloth or sponge. If necessary, disinfect the cuff by wiping it with 70% alcohol, mild bleach solution, or other disinfectant.

Disposable blood pressure cuffs are for single patient use and are not intended to be disinfected.

You can sterilize the cloth cuff and neoprene bag with commercially available disinfectants such as ethylene oxide (EtO). Rinse thoroughly to remove residual disinfectants. Do not allow liquids to enter the neoprene bag. The cloth cuff can also be sterilized in an autoclave.

If the cuffs become grossly soiled with blood or other body fluids, you should launder the cloth cuffs by hand or machine. You can launder or sterilize the dacron cloth cuff by first removing the neoprene inflation bag. Feed the inflation tube back through the hole and then pull out the cloth flap.



Figure 4-1: Remove Inflation Bag from Cuff

Roll up the inflation bag and slide it out the open slot in the cloth cuff. The following laundering precautions apply only to non-disposable cuffs. You should not launder disposable cuffs and neoprene inserts.

- Remove the inflatable bag from the cuff before laundering or sterilizing the cuff.
- Close the Velcro® fastener before you launder the cuff.
- Strong bleach solutions damage the cuff.
- Temperatures over 275° F (135° C) damage the cuff.
- Soaking the cuff in dark-colored solutions may stain or discolor the cuff.

Hand laundering (as opposed to machine laundering) prolongs the life of the cuff. Wash the cuff in warm, soapy water. Rinse the cuff thoroughly. After you clean the cuff, allow the cuff to air dry, then insert the inflation bag in the cuff.

ECG Cable You can clean the ECG cable and leads with alcohol. Do not immerse the connections.

Temperature Cable Clean the cable according to the hospital protocol for cleaning of reusable equipment cables.

Typically this protocol consists of the following steps:

1. Disconnect the cable from the monitor and temperature sensor.
2. Wipe the cable with a nonabrasive cloth moistened with a mild detergent and warm water or a disinfectant.
3. Dry thoroughly.
4. Do not use alcohol or solvents to clean the cable.
5. Do not allow the cable connectors and contact points to come in contact with liquids.
6. Do not fully immerse the cable in liquids.
7. Do not autoclave or EtO sterilize the cable.

Accidental Wetting

WARNING

- Shock Hazard! Because a monitor is an AC-powered device, an immersed monitor presents a danger to anyone who attempts to handle the device.

Immediately perform the following steps following an accidental wetting of equipment:

1. Turn the power off. Disconnect the AC power cord from the monitor.
2. If the monitor is monitoring a patient, transfer the patient to another monitor as quickly as possible.
3. Use a clean, dry towel or cloth to remove the liquid from the monitor housing.
4. A service technician should inspect the monitor as soon as possible.
5. If the internal mechanism is saturated, allow the liquid to drain out for 24 hours before shipping.
6. If liquid has entered the monitor, it must be dried and cleaned internally. Full testing is required before you can use the monitor. Contact the CSI service department as soon as possible.

Time is critical. The longer any liquid remains in the monitor, the more damage it can do. It is important to service the monitor immediately after any liquid is spilled into it.

Section 5 — Preventative Maintenance

Incoming Inspection

You must inspect monitors coming back from service for shipping damage before you place them into operation just like newly purchased monitors. The monitor should be free from dents, cracks, or other physical damage. The quality inspection seal of the monitor should be unbroken, indicating that the monitor has been tested according to manufacturer's specifications.

If further incoming inspection or testing is required, the manufacturer recommends that you use the Alarms Verification (located in this section) as an incoming inspection test. You can perform additional electrical safety testing in this section as part of an incoming inspection in accordance with the policies of the health care provider.

Maintenance Schedule

Every Patient	<ul style="list-style-type: none">• Clean and disinfect the sensor cables and sensor.• Inspect the accessories and cables for damage.
Every Day	<ul style="list-style-type: none">• Charge the monitor's battery.
Every 3 Months	<ul style="list-style-type: none">• Clean the exterior of the unit (or clean as needed).
Every Year	<ul style="list-style-type: none">• Perform the annual safety tests provided in this section.

NOTE: For additional maintenance of the CO₂ module, see "Appendix A – CO₂ Service."

Monitor Safety Testing

You can perform the following tests as part of a periodic safety check. The following safety tests are designed so that the monitor's warranty seal does not have to be broken. If the monitor fails any portion of these tests, contact the CSI service department.

The contents of this section, "Preventative Maintenance," include the following verifications and safety tests:

- Withstanding Voltage (Hi-Pot)
- Electrical Leakage
- Ground Continuity
- Interface Inspection
- Manual Controls Check
- Alarm Verification
- Vital Sign Modules Verification
 - ECG
 - SpO₂
 - NIBP
 - Temperature
- Internal Printer
- Communications
- Battery and Power

Criticare recommends that you run a serviced monitor for 24 hours before you perform the tests listed above and place the monitor back into service.

Repaired modules could require more extensive testing than what is shown in this list.



Always follow ESD precautions when performing a procedure discussed in this section.

WARNING

- Because test procedures require working with exposed electrical circuits, only experienced electrical or biomedical technicians should perform the procedures.
- After a monitor is altered through repair or hardware adjustment, you must fully test it before use.

Equipment and Tools The following procedures assume that the technician has an ESD safe workbench, a set of electronic hand tools, and a digital multimeter with a 10 amp setting. At the beginning of each test, special equipment can be listed. A variety of customized cables, clips, and test fixtures are also needed to complete the tests. For more information, contact the CSI Service Department.

Accessory Testing Check patient cables (e.g., temperature cables, printer cables) monthly for damage, loose wires/connections, loose connectors, cracked housing, etc.

Check the electrical safety of the power cord as part of the monitor safety testing.

Check the cuffs for leakage as part of the NIBP verification.

Fuse Removal/ Replacement

There are two (2) AC power fuses located at the rear of the monitor directly below the AC power entry socket.

- United States monitors use 1A 250V Time Lag fuses.
 - International monitors used in 220-240 volt environments use 1A 250V Time Lag fuses.
1. Remove power cord.
 2. Press in the side clips (at the same time) with a tool and lift out the access cover. The two (2) fuse sockets are visible

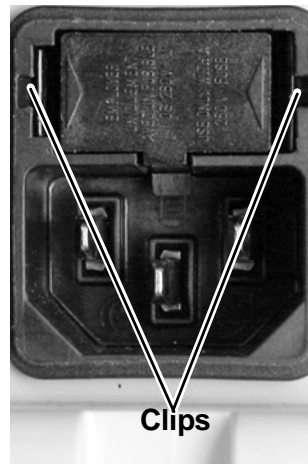

Figure 5-2: Remove the Fuse Cover

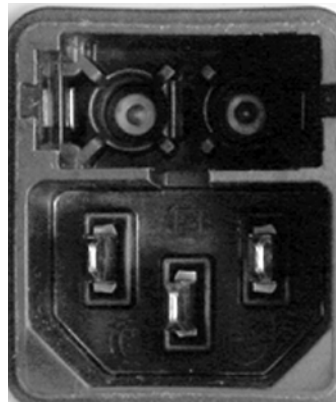

Figure 5-3: Fuses Exposed

3. Gently pull the fuses out of the fuse cover assembly.

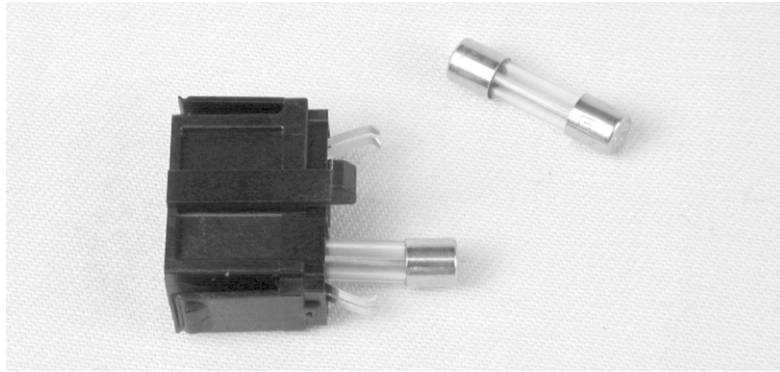

Figure 5-4: Fuses Pulled

4. Reassemble in reverse order.

For more information about troubleshooting power problems, refer to “Troubleshooting” in Section 8.

Long-Term Monitor and Battery Storage

No special preparation is necessary for long term storage of the monitor. Although you do not have to remove the battery from the monitor for long term storage, the battery drains to an unrecoverable state after 3 months without periodic charging.

Monitor and Accessories Disposal

At the end of its useful life, you can dispose of the monitor and its accessories according to your institution’s policies and procedures for disposal of patient-contact medical waste.

Alternately, you can return the monitor and its accessories to Criticare Systems, Inc., for safe disposal. The shipping address is:

Criticare Systems, Inc.
20925 Crossroads Circle, Suite 100
Waukesha, WI 53186

Electrical Safety Testing

Perform this test each time you open the monitor housing and before you use the monitor on patients.



WARNING

- Shock Hazard! Because dangerous and lethal voltages are present during the withstanding voltage, leakage, and ground continuity test, all leakage and voltage testing must be done with the monitor housing in place. For complete information about the proper operating and safety procedures, refer to the *nGenuity 8100E Series Patient Monitor Operator's Manual*.

Equipment Needed

The following are needed to complete this procedure:

- Kikusui TOS 8750 Withstanding Voltage Tester (or equivalent Hi-Pot tester)

Withstanding Voltage (Hi-Pot) Test Equipment and Setup

The following test and set-up is for the Kikusui TOS 8750 Withstanding Voltage Tester. If you use an equivalent tester, use the factory recommended test for that tester.

1. Test the Withstanding Voltage Tester by connecting the red and black lead together. Set the voltage to 1000 VAC.
2. Set timer for 1 second and cutoff current for 1 milliamp.
3. Press the **Test** button. The NG light should come on.

CAUTION

- If the NG light does not come on, do not continue with this test. You must repair or replace the withstanding voltage tester.

Withstanding Voltage (Hi-Pot) Test Procedure

NOTE: For the following tests set the Hi-Pot unit as follows:

	Memory #20	Memory #21
Arc Fail	OFF	OFF
Arc Sense	5	5
Ramp-HI	OFF	OFF
Charge LO	0.0 μ A	0.0 μ A
Dwell Time	1.0 sec.	1.0 sec.
Ramp Time	1.0 sec.	1.0 sec.
LO-Limit	0.0 μ A	0.0 μ A
HI-Limit	1000 μ A	1000 μ A
Voltage	2.500 KV	4.242 KV

1. Connect the red lead of the Hi-Pot to Hot/Neutral and the black lead to Chassis Ground (EPT). Set up the Hi-Pot per table above to Memory #20. Verify Hi-Pot is now set to a Trip Current of 1mA and test @2500VDC for 1 second.
2. Connect the red lead of the Hi-Pot to Hot/Neutral and the black lead to ECG. Set up the Hi-Pot per table above to Memory #21. Verify Hi-Pot is now set to a Trip Current of 1mA and test @4242VDC for 1 second.
3. Connect the red lead of the Hi-Pot to Hot/Neutral and the black lead to Temperature. Set up the Hi-Pot per table above to Memory #21. Verify Hi-Pot is now set to a Trip Current of 1mA and test @4242VDC for 1 second.
4. Connect the red lead of the Hi-Pot to Hot/Neutral and the black lead to SpO₂. Set up the Hi-Pot per table above to Memory #21. Verify Hi-Pot is now set to a Trip Current of 1mA and test @4242VDC for 1 second.
5. Connect the red lead of the Hi-Pot to Hot/Neutral and the black lead to BNC. Set up the Hi-Pot per table above to Memory #21. Verify Hi-Pot is now set to a Trip Current of 1mA and test @2500VDC for 1 second
6. Connect the red lead of the Hi-Pot to Hot/Neutral and the black lead to Nurse Call. Set up the Hi-Pot per table above to Memory #21. Verify Hi-Pot is now set to a Trip Current of 1mA and test @2500VDC for 1 second.

Leakage Test Equipment and Setup

Perform all testing with the cover on. The following test requires a Dynatech 232D leakage tester or equivalent.

1. Perform a self-test, if applicable, on the DYNATECH 232D by plugging it into 110 VAC outlet. Turn on the leakage tester. Set the mode switch to self test. Display should read 1000 ± 20 and the *CURRENT SOURCE ACTIVE* lamp should be on.

CAUTION

- If these conditions are not met, do not continue with this test.
2. Set the mode switch on the Dynatech 232 to **L1-L2** (line voltage). The display should read the line voltage $\pm 10\%$. Set the mode switch to **L1-GND**. The display should read no more than 5% of **L1-L2** on a grounded power system. Set the mode switch to **L2-GND**.

NOTE: This should read about the same as the **L1-L2** reading for a grounded system.

Leakage Test Procedure

The monitor must be powered up during all of the isolation tests.

1. Set the mode switch on the Dynatech 232 to L1-L2. The display should read the line voltage $\pm 10\%$. Set the mode switch to L1-GND. The display should read no more than 5% of L1-L2 (line voltage) on a grounded power system. Set the mode switch to L2-GND. This should read about the same as the L1-L2 reading for a grounded system.
2. Turn the mode switch to CASE LEAKAGE GROUND CONDUCTOR. Connect the AC cord from the Dynatech 232D to the 8100E(P) and turn on the unit. With the POLARITY switch in the NORMAL position, Press OPEN GROUND and monitor the readout for less than 500 μA .

Verify that the green AC LED lights up on the front membrane.

NOTE: The 8100E Series monitor must be powered up during all of the isolation tests.

3. Change the polarity switch to the REVERSE position, press OPEN GROUND and monitor the meter for less than 500 μA .
4. With the POLARITY switch in the NORMAL position, press OPEN NEUTRAL and OPEN GROUND switches and monitor the meter for less than 1 mA.
5. Change the POLARITY switch to the REVERSE position and press the OPEN NEUTRAL and OPEN GROUND switches and monitor the meter for less than 1 mA.

6. Connect a Dynatech 232 or equivalent to the 8100E Series monitor using the 5 lead ECG cable marked Cat 1075/S. Change the MODE switch to ECG. For the rest of the Leakage test insure that the leads are dressed away from the ground planes and the AC power cords and the chassis. Set the LEADS selector switch to ALL TO GND. Set the POLARITY switch to NORMAL. Monitor the meter for less than 5 μ A.
7. Set the POLARITY switch to REVERSE and monitor the meter for less than 5 μ A.
8. Set the POLARITY switch to NORMAL and press the OPEN NEUTRAL switch and monitor the meter for less than 10 μ A.
9. Set the POLARITY switch to REVERSE and press the OPEN NEUTRAL switch and monitor the meter for less than 10 μ A.
10. Set the POLARITY switch to NORMAL and press the OPEN GROUND switch and monitor the meter for less than 10 μ A. For inline voltages of 264V, meter for less than 20 μ A.
11. Set the POLARITY switch to REVERSE and press the OPEN GROUND switch and monitor the meter for less than 10 μ A. For inline voltages of 264V, meter for less than 20 μ A.
12. Turn the LEADS selector switch to the ISO Position. Turn the POLARITY switch to NORMAL, press the ISO TEST button, and monitor the meter for less than 20 μ A. For inline voltages of 264V, meter for less than 50 μ A.
13. Keep the power cord plugged into the unit under test and the Dynatech. Unplug the 8100E Series ECG cable from the 8100E Series monitor. Unplug the ECG test leads from the Dynatech. Connect the SpO₂ cable end to any of the BROWN ECG test terminals on the Dynatech. Connect the other end to the SPO2 connector on the monitor under test. MODE switch should be on ECG. Change the LEADS switch to ISO. Set the POLARITY switch to NORMAL. Press the ISO button and monitor the meter for less than 20 μ A. For inline voltages of 264V, meter for less than 50 μ A.
14. Keep the power cord plugged into the monitor under test and the Dynatech. Unplug the SpO₂ cable from the 8100E Series monitor. Unplug the test leads from the Dynatech. Connect the Temp cable end to any of the BROWN ECG test terminals on the Dynatech. Connect the other end to the TEMP connector of the monitor under test. MODE switch should be on ECG. Change the LEADS switch to ISO. Set the POLARITY switch to NORMAL. Press the ISO button and monitor the meter for less than 20 μ A. For inline voltages of 264V, meter for less than 50 μ A.
15. Verify the green AC LED lights up on the front membrane.

Ground Continuity Test This portion of the test requires a ROD-L Model 25 Ground Continuity Tester, or equivalent.

Do the following before turning on the ground tester:

1. Set the ground continuity tester to the resistance trip point setting of 0.1 ohms.
2. Set test time of 6 seconds. Set the tester to ground test only. Set the test current to 25 AMP's.
3. Turn on the ground tester.
4. Plug in the AC cord from the ground continuity tester to the monitor being tested.
5. Connect the ground cable to the chassis ground on the rear of the monitor.
6. Press the **Reset** button on the tester. Press the **Start** button.
7. The monitor passes if the Fail Light does not come on or if the resistance does not exceed 0.1 ohms during the test.

Functional Testing

- Interface Inspection** This procedure is for the monitor's TFT active display.
1. Verify that a readable screen displays. For a guide to proper screen layout, refer to the *nGenuity 8100E Series Patient Monitor Operator's Manual* for sample screens.
 2. Verify that the screen display is clear and bright when you directly face the monitor.
- Manual Controls Check**
1. Verify that rotating the menu knob moves the cursor through the menu items. Verify that when you press the menu knob on a highlighted menu item the monitor displays a sub-menu.
 2. Use the menu knob to enter the *CONFIG* window and set the date and time for the real time clock.
 3. Press the FREEZE key. Verify that you get an audible response from the speaker. Press the FREEZE key again to unlock the waveforms.
 4. Press the TREND key. Verify that you get an audible response from the speaker. A *Trend* window appears on the display. Press the TREND key again to close the *Trend* window. (Or optionally, press and hold the TREND key to open the *TYPE/INTERVAL/SCREEN* menu that you close by selecting *EXIT*.)
 5. Press the STANDBY key. Verify that you get an audible response from the speaker. A standby confirmation menu should appear. Highlight *NO* and press menu knob to exit.
 6. Press the DEFAULT key. Verify that you get an audible response from the speaker. The *Custom Default* menu appears. Select *CANCEL* and then press menu knob when *No action taken* is highlighted to exit.

- Alarms Verification** To verify the alarm circuitry for SpO₂, perform the following procedure.
1. In the *PARAMS* window turn off all monitoring modules except for SpO₂. Set the display to show a plethysmograph waveform.
 2. In the *PARAMS* window set the *SpO2 Low Limit Alarm* setting to *HIGH*. This sets the alarm priority for only this alarm parameter.
 3. Use an SpO₂ simulator to set the monitor to display the plethysmograph waveform. Confirm the heart rate and saturation reading.
 4. In the *ALARMS* window adjust the SpO₂ low alarm level above the saturation reading to cause an alarm condition.
 5. Verify that the message *LOW SPO2* appears at the top of the waveform channel in red letters.
 6. Verify that you get an audible response. The alarm should be a high priority alarm tone consisting of 3 beeps followed shortly by two beeps.
 7. In the *PARAMS* softkey window, change the *SpO2 Low Limit Alarm* setting to *MEDIUM*.
 8. Verify that the message *LOW SPO2* appears at the top of the waveform channel in yellow letters.
 9. Verify that you get an audible response. The alarm should be a medium priority alarm tone consisting of 3 beeps.

ALARM VOLUME TEST

1. From the *ALARMS* window, vary the *ALARM VOLUME* through the ranges, from *OFF* to *10*. Verify that the speaker volume changes according to the setting of the *ALARM VOLUME*.
2. Press the alarm *SILENCE* key once. Verify that the low heart rate alarm stops for 2 minutes and that the *2-minute Alarm Silence* icon appears in the system status area of the screen.
3. Press and hold the alarm *SILENCE* key for at least 2 seconds. Verify that the low heart rate alarm stops and the *Alarm Suspend* icon appears in the system status area of the screen.

- Printer Check** The printer only prints if the green battery light is ON or the AC (mains) cord is plugged in.
1. Lift the paper feed lever up and insert paper. Close the lever and the paper should automatically feed.
 2. In the *PRINT* window, set the *Print Type* to “Tabular.” Press the *PRINT* key on the front of the monitor.
 3. Verify that the correct date and time print.

Module Verification

- ECG Verification** This test requires a Dynatech Nevada Model 300 simulator, or equivalent.
1. Select the menu to set up for *ECG PARAMS* to *5-Lead*, *ECG ON*, Filters: *MONITOR*, *SENSITIVITY* to *HIGH*.
 2. Insert a shorted ECG cable into the ECG connector. Use the menu knob to enter the *DISPLAY* window. Set the following and use the current defaults for the size. They are 25MM except waveform 3:
 - Waveform 1 ECG I x 4.0 25.0
 - Waveform 2 ECG II x 4.0 25.0
 - Waveform 3 ECG V x 4.0 25.0
 3. Exit the *DISPLAY* window. Verify that the baselines are centered. Verify that the base line signal is no greater than 3 pixels in height. Select the most solid line as the reference line and verify that this reference is less than ± 3 pixels from the ECG y-axis center line. If they are not, adjust pots R12 (Waveform 1), R110 (Waveform 2) and R108 (Waveform 3). Remove the shorted cable.
 4. Verify that the message *LEADS OFF* appears at the top of the window when no cable is connected.
 5. Connect the 3-lead ECG patient cable CAT 1075/S to the ECG cable assembly, and use a Dynatech Nevada Model 300 simulator to turn on (ECG) normal sinus, 60BPM, amp 1.0mV, axis int. Respiration rate 20, and the impedance set for 0.5 ohms, and base impedance for 2K.

6. Rotate the menu knob to select *PARAMETERS* and press to enable the menu. Select *ECG* for (3 LEADWIRE). Set the monitor for *LEAD II* waveforms.

Check the following lead configurations for following items:

- heart rate 60 ± 3 BPM,
- *RESPIRATION RATE* of 20 ± 2 breaths per minute and
- correct waveform.

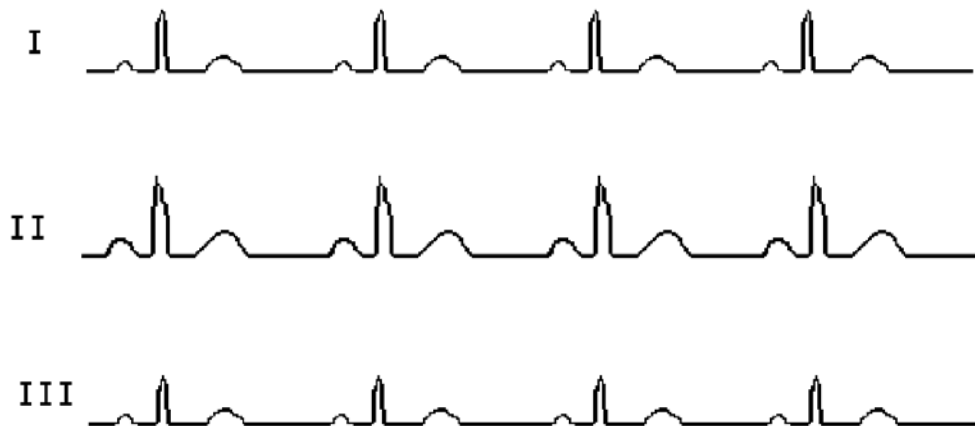

7. Use the Electrode status error messages on the CRT to perform a lead off check in LEAD II.

- (LL) Red LL LEAD OFF
- (LA) Black LEADS OFF
- (RA) White RA LEAD OFF

8. Connect all the leads back on the simulator and select *ECG* to *5-lead*. Set the monitor for LEAD II waveforms. Disconnect the following leads one at a time and look for the proper status error message and for the waveform to continue or flatline.

Reconnect the lead and the message should disappear and the waveform should return, if it flatlined.

- (V1) Brown V LEADS OFF
- (LL) Red LL LEADS OFF
- (LA) Black LA LEADS OFF
- (RA) White RA LEADS OFF
- (RL) Green LEADS OFF

9. Check the following lead configurations for following items:

- Heart rate 60 ± 3 BPM,
- resp. rate 20 ± 2 BPM and
- correct waveforms.

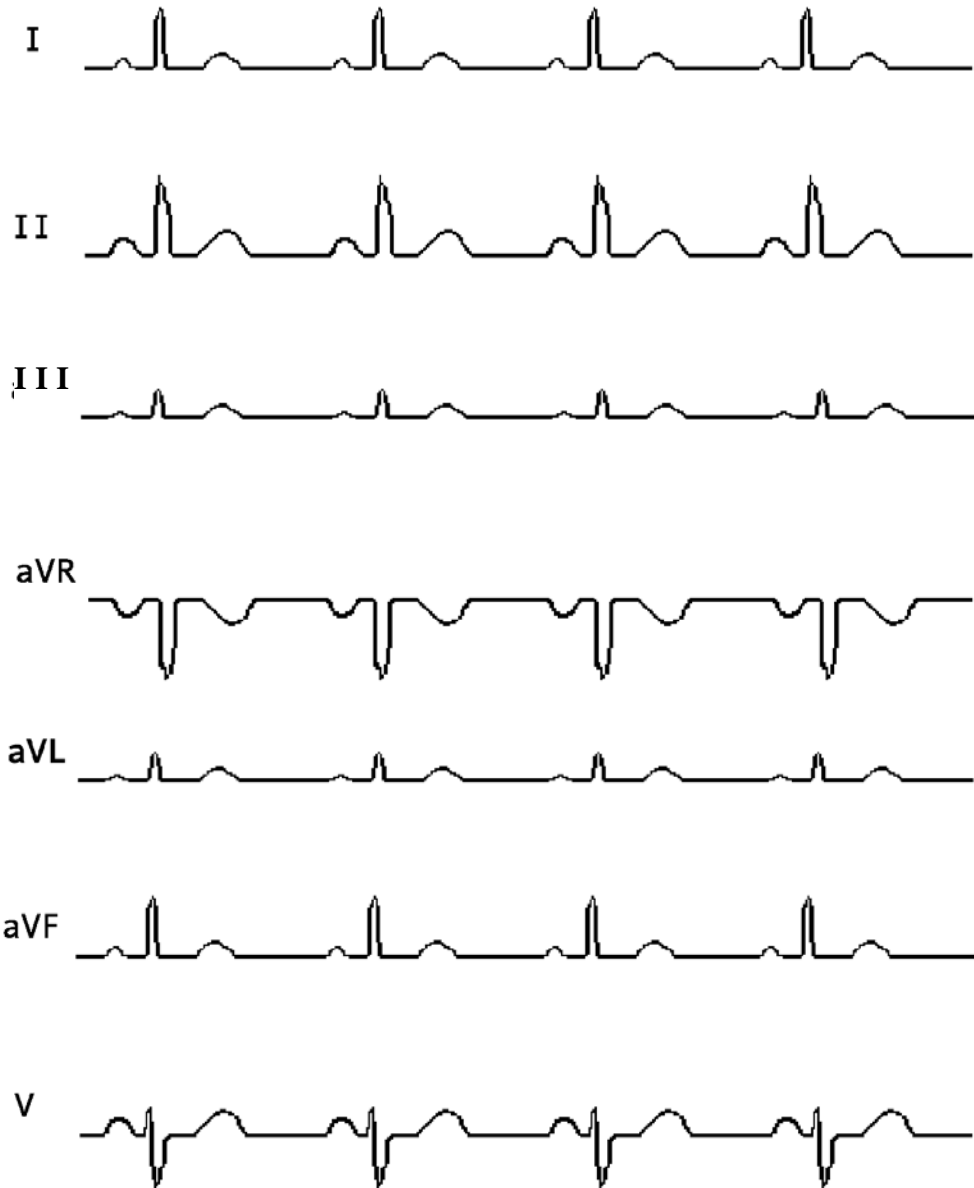

10. Verify that the respiration rate changes from 20 to 30bpm, when changing on the MED SIM 300.

11. Rotate the menu knob to highlight *Display* and press to select. Under waveforms 3-6, Select:

- *RESP* as *TYPE*,
- *GAIN* as *1.0*,
- *SWEEP* as *25MM/SEC* and size.

The size might not be changeable on some waveforms. Select *Exit* and verify that a non symmetrical sine wave displays on the window.

12. Set the Dynatech MED SIM300 to a heart rate of 300BPM. Verify that the ECG HR reads *300BPM ±1BPM*.

13. Turn off the simulator and verify that the message *ECG LOST* appears at the top of the window.

14. Turn the simulator back on and set the simulator for 60BPM, LEAD II and verify that the gain settings are effective at x.5, x2, and x4 for 1mv ECG input.

15. Select on the simulator for ECG performance. Cursor through the menu until you obtain and execute twice the *PACED RYTHMS*. Verify that PACE is turned on in the menu screen of the 8100. You should see white spikes on the waveform and 75BPM.

16. Select **ECG** on the simulator, select **base**, then **BPM**, and **60**. This gives a normal sinus rhythm at this time. Select **ECG**, then **ARRH**, then **VNT2**, and then **VFIB**. The unit should detect an erratic baseline and display the message *ECG LOST*.

ECG Analog Output Test You need a MedSim 300 patient simulator to perform this procedure.

1. Connect a BNC cable with 0.1uf CAP signal-to-ground from the ECG BNC on the monitor to an input channel on an oscilloscope.
2. Select and press the *PARAMS* softkey.
3. Set *Filter* to *Diagnostic* and *ECG Sensitivity* to *Medium*.
4. Select and press the *DISPLAY* softkey.
5. Set *Waveform 1* for ECG Lead II (*ECG II*) on the screen.
6. Set the MedSim 300 patient simulator for “tri s10” (triangle waveform).
7. Verify that the baseline is zero and signal is a peak-to-peak voltage of 1.2V (±0.2).

Diagnostic, Monitor, and ST Filter Mode Tests

1. In the *PARAMS* menu, set *FILTER* to *DIAGNOSTIC*. On the simulator, select *PERF* under *ECG*, then *WAVE*, and then "s10" (10 Hz sine wave). Verify on the monitor that the S40 simulator sine wave signal displayed has amplitude no less than 0.95 X "s10" (10 Hz sine wave). To accomplish this, measure the peak-to-peak amplitude of the 10 Hz sine wave in waveform, then measure the peak-to-peak amplitude of the 40 Hz sine wave. There shall be no more than a 5% decrease (40 Hz amplitude = or > 0.95 X 10 Hz amplitude).
2. Select *MONITOR* filtering. The 40 Hz sine wave displayed on the monitor display shall be 0.70 X the input amplitude in mV when the simulator is set to "s10" (10 Hz sine wave). Measure as described in the previous step.
3. Select *ST* filtering. The 40 Hz sine wave displayed on the monitor shall be 0.70 X the input amplitude when the simulator is set to "s10" (10 Hz sine wave). Measure as described in the previous step. Set *FILTER* back to *DIAGNOSTIC*.
4. On the simulator, use the > arrow to select "s0.05" for a 0.05 Hz sine wave. In the monitor's *DISPLAY* menu select a sweep speed of 12.5 mm/sec. The 0.05 Hz sine wave shall be 0.70 X the input amplitude as displayed on the monitor when the simulator is set to "s10" (10 Hz sine wave). Measure as described in the previous step.
5. Select *MONITOR* filtering. The 0.05 Hz sine wave is no longer present (flat baseline). On the simulator, select "s0.5" (0.5 Hz sine wave) and verify that a 0.5 Hz sine wave with amplitude equal to 0.70 X the 10 Hz sine wave amplitude is present. Set the simulator back to "s0.05".
6. Select *ST* filtering. The 0.05 Hz sine wave should have an amplitude equal to 0.70 X the 10 Hz sine wave amplitude. Set the *FILTER* back to *DIAGNOSTIC*. Select 10Hz on the simulator.
7. Turn off the simulator, Verify that the message *ECG LOST* appears at the top of the screen.

SpO₂ Verification The following test requires a SmartSat SpO₂ analyzer. If you service the monitor (i.e., you open the housing), use the longer SpO₂ Performance test. For more information, refer to “DOX SpO₂ Performance Testing” on page 6-3.

NOTE: For older revision SmartSat analyzers that do not have a Model 8100 selection, use the general Criticare selection in the SmartSat simulator. Check the SpO₂ value of 52% (±3%) with the analyzer set to 42%.

1. Verify that the message *SPO2: NO SENSOR* appears when there is nothing connected to the **SpO₂** connector.
2. Verify that the message *SPO2: HIGH AMBIENT* appears by introducing a higher than normal amount of ambient light on the SPO2 sensor detector. Verify the message disappears within 10 seconds after you remove the ambient light.
3. Verify that the message *SPO2: SENSOR* appears when you plug the finger sensor in, but without a finger actually inserted into the sensor.
4. Use an SpO₂ finger sensor and verify that the heart rate and plethysmograph operation display on the LEDs within 15 seconds. Verify that SpO₂ error messages do not appear (alarm violations can occur depending on individual readings and monitor set-up).
5. Verify the LCD displays a plethysmograph waveform. Connect cable CAT 931A to COM2. Plug BNC-A of the cable into a oscilloscope channel. In the *CONFIG* window, *ANALOG OUT SELECT*, select *PLETH*. Use the SpO₂ finger sensor to verify that the SpO₂ waveforms appear on the scope. The waveform should be centered on 0 volts and register 1 volt peak-to-peak. Remove the CAT 931A cable.
6. Verify that the pulse tone increases as you change the tone from 1 to 10 in the *Alarm Setting* window.
7. Use an optical load to simulate a small signal and verify that the message *SPO2: SEARCH or LOST* appears after search delay time ± 5 seconds. (An optical load that can be used for this test is a foam peanut used for packing.)

NIBP Verification The NIBP verification requires Dynatech Nevada NIBP Analyzer, or equivalent.

Connect the 8100E Series monitor to a Dynatech Nevada NIBP Analyzer set for the following operation.

NIBP Analyzer Settings

Adult 120/80 (90); Heart Rate 80 bpm

Neonate 80/50 (62); Heart Rate 80 bpm

Pressure Adjustments: Gain 100%; Shift 4

1. Use the T-connection with the dummy cuffs for these tests. Connect them to the 0-300 mmHg port of the NIBP analyzer.
2. Connect the monitor to an AC (mains) power source and turn on the monitor.
3. Press the monitor's NIBP CYCLE/STAT key. The monitor's cycle time window appears.
4. Select the *NIBP Cycle Time* to two minutes.

120/80 OPERATION SETTING

1. In the monitor's *ADM/DIS* window set the *Patient Size* to *Adult* mode.
2. Connect the NIBP hose to the fitting on the monitor.
3. Press and hold the NIBP key.
4. Allow the monitor to take at least four (4) readings. Calculate the average of the four (4) readings and verify that each reading does not vary by more than $\pm 4\%$ or $\pm 4\text{mmHg}$ (whichever is greater) from the calculated average. Each reading shall not vary more than 8 mmHg from the simulator setting.
5. Recalibrate the monitor if necessary.

80/50 OPERATION SETTING

1. Set the monitor to the *Neonate* mode.
2. To verify *STAT* mode operation, press and hold the NIBP CYCLE/STAT key.
3. Allow the monitor to take at least four (4) readings. Calculate the average of the 4 readings and verify that each reading does not vary by more than $\pm 4\%$ or $\pm 4\text{mmHg}$ (whichever is greater) from the calculated average. Each reading shall not vary more than 8 mmHg from the simulator setting.

Temperature Verification This section requires the use of a Fogg TP400/700 simulator. This simulator is available from Fogg Company Systems, Inc. Or an equivalent simulator may be used.

1. Select *Temperature ON* from the *PARAMS* window and *TEMP F/C: (Centigrade)*. Connect the temperature to TEMP on the monitor. Insert the simulator (TP 400).
2. Verify that simulator settings correctly display for all temperatures that range from 20° C to 45° C with accuracy of $\pm 0.1^{\circ}$ C.
3. Verify that the message *TEMP INVALID* appears when the temperature is at 0 for *TEMP*.
4. Select *Temperature ON* from the menu setup and *TEMP F/C: (Centigrade)*. Connect the temperature to TEMP on the unit. Insert the simulator (TP 700).
5. Verify that simulator settings correctly display for all temperatures that range from 20° C to 45° C with accuracy of $\pm 0.1^{\circ}$ C. Verify that *TEMP INVALID* appears when the temperature is at 0.

Communication Testing

Nurse Call This test requires the use of a Nurse Call fixture. This fixture may be created by using the schematic below:

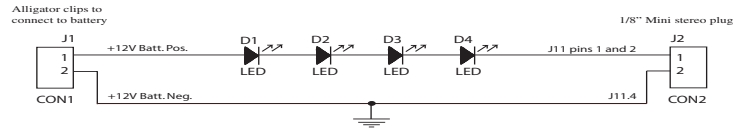

1. Connect the Smart Sat and monitor all levels.
2. Connect the Nurse Call fixture into the back of the monitor while the Smart Sat simulator runs.
3. Create an alarm state with the Smart Sat, and verify that the lights on the Nurse Call fixture go on.
4. Press *the Alarm Silence* button, and verify that 2 minutes appears at the top of the display and the lights on the Nurse Call fixture go off and remain so for two (2) minutes while the in the alarm state.
5. Press and hold the *Alarm Silence* button. The Nurse Call fixture should go off and remain off regardless of changing alarm states.

NOTE: While in the 2 minute Alarm Silence, if the alarm states change, the Nurse Call fixture lights will come back on. While in permanent alarm silence, the lights on the Nurse Call fixture should remain off regardless of changing alarm states.

Battery and Power Testing

This procedure provides a method of testing the power regulation and battery charging circuits of the main board. This test does not require you to open the monitor housing and break the warranty seal.

WARNING

- Shock Hazard! Do not attempt to power the monitor with an external DC source, while sensors are attached to a person. Always use vital signs simulators when using alternate power sources during testing.
- If voltages exceeding those listed are applied, permanent damage will occur.

Test the Battery

1. Set a power supply to 13VDC (± 0.25 VDC). Attach the power supply module to the battery terminals of the monitor under test. Turn on the monitor under test and verify that the *green* battery icon is present.
2. Lower the voltage with the adjustment of the power supply to a voltage of between 11.55 and 11.40 VDC and verify a *yellow* battery icon appears.
3. Lower the voltage to between 11.30 and 10.50 VDC and verify that a *black* battery icon appears.
4. Continue to decrease the voltage and verify that the unit shuts down at 10.2 VDC (± 0.5 VDC).

Functional and Safety Testing Checklist

Functional and Safety Testing Checklist (Page 1 of 2)		
SERIAL NUMBER _____		
Tester _____	DATE _____	
SOFTWARE REV. MAIN _____	SOFTWARE REV. CONM _____	SOFTWARE REV. VSM _____
	PASS	FAIL
Verify 1 Amp fuses	_____	_____
Verify Ground Continuity	_____	_____
Verify Hi-Pot:		
Hot/Neutral to EPT @ 2500VDC	_____	_____
Hot/Neutral to ECG @ 4242VDC	_____	_____
Hot/Neutral to Temperature @4242VDC	_____	_____
Hot/Neutral to Spo2 @4242VDC	_____	_____
Hot/Neutral to BNC @2500VDC	_____	_____
Hot/Neutral to Nurse Call @2500VDC	_____	_____
Verify Leakage:		
Self test 1000 ±20	_____	_____
Line voltage on Dynatech 232	_____	_____
Case leakage GND Con Ext. OPEN GND NORMAL <500µA	_____ µA	_____ µA
Case Leakage GND CON OPEN GND REVERSE <500 µA	_____ µA	_____ µA
Open Neutral Open GND Normal <1mA	_____ µA	_____ µA
Open Neutral Open GND Reverse <1mA	_____ µA	_____ µA
ECG Mode to GND Normal <5UA	_____ µA	_____ µA
ECG Mode to GND Reverse <5UA	_____ µA	_____ µA
Open Neutral Normal < 10UA	_____ µA	_____ µA
Open Neutral Reverse <10uA	_____ µA	_____ µA
Open GND Normal <10uA for 120V input	_____ µA	_____ µA
(<20µA if line voltage is 264V)	_____ µA	_____ µA
Open GND Reversed <10µA for 120V input	_____ µA	_____ µA
(<20µA for 264V line voltage)	_____ µA	_____ µA
ISO test ECG Normal <20µA for120V input	_____ µA	_____ µA
(<50µA if line voltage is 264V)	_____ µA	_____ µA
ISO test SPO2 Normal <20µA for 120V input	_____ µA	_____ µA
(<50µA @ 264V line voltage)	_____ µA	_____ µA
ISO test Temp Normal <20µA for 120V input	_____ µA	_____ µA
(<50µA @ 264V line voltage)	_____ µA	_____ µA
Verify AC light is on	_____	_____
Verify that the SPO2 Smart Sat is operational	_____	_____
Verify that Nurse Call is operational	_____	_____
Verify that Alarm Volume is increases	_____	_____
Verify 2 min ALARM SILENCE ICON	_____	_____
Verify ALARM OFF	_____	_____
Verify correct software revision	_____	_____
Verify correct serial number and software	_____	_____
Connect to computer using COM 1	_____	_____
Connect download cable	_____	_____
Cal 0 for NIBP	_____	_____
Verify communication with Calibration Program	_____	_____
Accepted calibration for 0	_____	_____
Accuracy readings are within 2% or 3 in. hg.	_____	_____
Verify the Speed Test (12-15 s inflate, <10 s deflate)	_____	_____
Verify that the Leak Test < 4mmHg/min	_____	_____
Timeout for Adult	_____	_____
Verify Leak Test Neonate (<4mmHg/min)	_____	_____
Verify timeout Neonate	_____	_____
Safety Test Adult	_____	_____
Safety Test Neonate	_____	_____
Adult Reading on 2 min (4 readings)	_____	_____
Neonate Reading on STAT MODE (4 readings)	_____	_____

Functional and Safety Testing Checklist (Page 2 of 2)

	PASS	FAIL
Monitor powers up on Battery only	_____	_____
ON Current Base < 1400mA	_____	_____
Verify that charging works on BATT	_____	_____
Verify GREEN BATTERY ICON	_____	_____
Verify YELLOW BATTREY ICON	_____	_____
Verify BLACK BATTERY ICON	_____	_____
Verify SHUTDOWN @ 10.0 (±0.5) VDC	_____	_____
If active is connected, full view is readable	_____	_____
Verify that the display meets the criteria	_____	_____
Verify SPO2 <i>NO SENSOR</i>	_____	_____
Verify SPO2 <i>HIGH AMBIENT</i>	_____	_____
Verify SPO2 <i>SENSOR</i>	_____	_____
Verify SPO2 Readings with HR	_____	_____
Verify PULSE TONE	_____	_____
Verify SPO2 <i>SEARCH OR LOST</i>	_____	_____
Verify Temp Accuracy 20 to 45 degrees C TP400	_____	_____
Verify Temp Accuracy 20 to 45 degrees C TP700	_____	_____
Verify Temp <i>INVALID</i> for both	_____	_____
Verify baselines are set @ x4 and no more than 3 pixels	_____	_____
Verify <i>LEADS OFF</i> message	_____	_____
Verify 3-Lead operation for LEAD I, II, III, verify 60bpm and 20bpm for respiration	_____	_____
Correct leads off message in Lead II	_____	_____
Correct Lead off messages for five lead	_____	_____
Verify 5-lead operation for I, II, III, AVL, AVR, AVF, V	_____	_____
Verify Respiration @ 20 BPM	_____	_____
Verify Respiration waveform	_____	_____
Verify the HR @300 BPM	_____	_____
Verify that the gain works @ . 5mv, 2mv, & 4mv	_____	_____
Verify Pace detect is functional @ 75BPM	_____	_____
Verify <i>ECG LOST</i> is detected from VFIB	_____	_____
Verify that ECG out works from J11	_____	_____
Verify Sine wave < 5% decrease	_____	_____
Verify sine wave in Monitor Mode	_____	_____
Verify sine wave in ST filtering	_____	_____
Measure the sine wave @ .05Hz	_____	_____
In Monitor mode @ .5Hz	_____	_____
Verify ST mode @ .05Hz	_____	_____
Verify <i>ECG LOST</i> when the simulator is turned off	_____	_____
Verify encoder works	_____	_____
Verify time & date are set	_____	_____
Verify that FREEZE button is operational	_____	_____
Verify that the TREND button works	_____	_____
Verify that the STANDBY button works	_____	_____
Verify that the DEFAULT button works	_____	_____
Verify that printer paper feed works.	_____	_____
Verify that printer is operational	_____	_____
Verify external monitor is functional	_____	_____
Verify that serial number is correct	_____	_____
Verify all hardware is tight and properly sealed	_____	_____

CERTIFICATION THAT THE UNIT IS FUNCTIONING PROPERLY.
 NAME _____ DATE _____

CERTIFICATION OF FUNCTIONAL AND SAFTEY TESTING
 TECHNICIAN _____ DATE _____

This checklist may be copied as needed to record field testing

Section 6 — Service Testing and Calibration

Field Service Testing Safety



WARNING

- Service testing procedures require working with exposed electrical circuits and should only be attempted by experienced electrical or biomedical technicians.
- When a monitor is altered through repair or hardware adjustment, it should be fully tested before use.



CAUTION

- Always follow ESD precautions when performing any procedure discussed in this section.
- The manufacturer recommends that a serviced monitor be allowed to run for 24 hours before the monitor is placed back into operation.
- Modules and PCBs that have been repaired may require more extensive testing than what is described in this manual.

The pre-assembly testing of printed circuit boards (PCBs) is not covered in this manual. Disassembly of surface mounted components on PCBs is not recommended. Tests provided here are only for the identification of damaged or degraded PCBs.

Field Service Test Matrix

Any time you open a monitor's case you must perform electrical safety tests before you return the monitor to operation. If you service the monitor, you should also perform the functional tests.

You should perform additional tests that are specific to modules and assemblies when you service, adjust, calibrate, or disassemble assemblies. See the following table.

Field Service Testing	<ul style="list-style-type: none"> ● Required Test ✓ Recommended Test 															
	Withstanding Voltage (Hipot)	Electrical Leakage	Ground Continuity Test	Functional Testing	ECG Verification	SPO ₂ Verification	NIBP Verification	CO ₂ Absorber Verification	Gas Flow/CO ₂ Verification	Temperature Verification	Communication Testing	SpO ₂ Performance Test	NIBP Module Calibration	CO ₂ Calibration	Temperature Check	Main Board Testing
No Fault (case opened)	✓	●	✓	✓					✓							
NIBP Pump	✓	●	✓	✓			●		✓			●				
SPO ₂ Board	✓	●	✓	✓		●			✓		●					
ECG/Analog Board	✓	●	✓	✓	●	✓			✓	●	●					
CO ₂ Absorber				✓				●	●							
CO ₂ Board	✓	●	✓	✓					●				●			
Main Board	✓	●	✓	●	●	●	●		✓	✓	●	✓		●	●	
Display/Inverter Board	✓	●	✓	●					✓							
Membrane Key Pad	✓	●	✓	●	✓	✓	✓		✓	✓	✓					
Printer and/or Board	✓	●	✓	✓												
Power Module	✓	●	✓	●	✓	✓	✓		✓	✓	✓					
Instrument Dropped	✓	✓	✓	✓	✓	✓	✓		✓	✓	✓					
Software Download				●	✓	✓	✓		✓	✓	●					
Annual Safety Test	✓	●	✓	✓	✓	✓	✓		●	✓						

Field Calibration Procedures

Some of the following procedures require specialized equipment that could be available only to larger service facilities.

Criticare recommends that NIBP calibration and calibration of the ECG/Analog Board be performed at CSI authorized service facilities.

NOTE: For testing and calibration of the CO₂ module, see “Appendix A – CO₂ Service.”

DOX SpO₂ Performance Testing

This test requires a SmartSat Pulse Oximetry Analyzer, Model SS-100A. The SmartSat is a programmable simulator and probe analyzer. The SmartSat is the recommended device for testing the DOX SpO₂ module. The SmartSat, model SS-100A, is available from Clinical Dynamics Corp. of Wallingford, CT.

The SmartSat comes standard with Lemo style connections. The Cat. No. 913A adapter that converts Lemo to DB-9 style SpO₂ connections is needed for the 8100E Series. The analyzer also has a custom port designed for testing DOX™ SpO₂ sensors.

Programming the SmartSat Analyzer

The SmartSat can be used for spot checking SpO₂ values using the manual settings. The manufacturer recommends using a timed and programmed sequence to ensure that there is optimal performance.

For older revisions of SmartSat Analyzer that does not have a program for the Model 8100E monitor, program the SmartSat as specified below. Verify that the monitor's display value matches the corresponding value in the test procedure, not the program settings.

AUTO SEQ: MODEL 8100E			Oximeter DOX	
Step	Time	Mod	Setting	Rate
1	18s	5.00	99	40
2	20s	5.00	96	60
3	20s	5.00	89	80
4	20s	5.00	73	100
5	20s	5.00	52	120
6	20s	5.00	42	180
7	20s	5.00	26	300
8	END			

Recent versions of the SmartSat Analyzer are pre-loaded with a different program, but utilize the same test.

Test Procedure

1. Verify the SpO₂ module. (For verification, refer to “SpO₂ Verification” on page 5-18.)
2. Attach the monitor to the SmartSat.
3. Start the SmartSat programmed sequence: *SmartSat Auto Sequence*. Verify that the monitor's reported SpO₂ values are within the limits specified.

Level	Saturation(%)	Limits(%)	Heart Rate	Limits
1	99	97 - 99	40 bpm	39-41 bpm
2	96	94 - 98	60 bpm	59-61 bpm
3	90	88 - 92	80 bpm	79-81 bpm
4	78	76 - 80	100 bpm	99-101 bpm
5	61	58 - 64	120 bpm	119-121 bpm
6	52	49 - 55	180 bpm	179-181 bpm
7	40	37 - 43	300 bpm	297-303 bpm

4. Even if the monitor fails only one level, rerun the sequence after 30 seconds. Only if the monitor is successful the second time, do you pass the monitor.
5. If the monitor fails again, contact the CSI service department.

SpO₂ Board Test Values

While the DOX SpO₂ Board is in operation, it should conform with the following test values. The operational current draw of the board should be less than 50 ma. Use TP4 as ground for each measurement.

Test Point	Signal	Value
TP3	-5A	-5V (±0.05V)
C9(+)	+10	+10V (±0.20V)
TP2	+5D	5V (±0.05V)
VR1 (4)	-2.5VREF	-2.5V (±0.03V)

1. If the any of these values fail to test correctly, isolate the problem to either the SpO₂ Board or the power supply circuits.
2. Remove the SpO₂ Board from the monitor.
3. Test the equivalent signals on the ECG/Analog Board circuits, -5A, +10, +5D, -2.5VREF. See “Assembly Tests” on page 7-9.
4. If the values return to normal with the SpO₂ Board removed, replace the SpO₂ Board.

NOTE: The ECG/Analog Board provides power to the SpO₂ Board.

The DOX SpO₂ Board can be replaced as a serviceable component. The downloadable software settings associated with the SpO₂ module are stored on the ECG/Analog Board. No calibration or SpO₂ Board preparation is required.

NIBP Calibration

Equipment Required:

- CAT #1320 kit, which includes: NIBP Service Program (pn 97082A003, Rev. 2)
- PC computer configured for use with CSI Service Software
- 8100 serial download cable, CAT #1320 (pn 90840A004)
- 700cc dummy cuff
- ESD protected workbench
- Digital reference manometer
- Dynatech Nevada NIBP Analyzer

Installing the PC Service Program

The NIBP Service Program is provided on a self-installing CD ROM disk (pn 97082A003, Rev. 2). If the CD ROM does not run automatically you may need to click on the CD ROM icon.

Run the auto-installation disk. The program *NIBPsvc.exe* will be loaded into the Program Files directory. The new folders *CSI\Tools* will be created. A launch icon will also be placed on the desktop of the computer.

Configuring the Ports

The Service Program is designed to operate using a serial COM1, COM3 or COM4 port. If your computer uses USB ports instead of a serial port an adapter will be required. The following adapters are recommended:

- IOmega USB to Serial/PDA Converter Cable (GUC232A)
- Keyspan USB Serial Adapter (USA-19HS)

If COM1, COM3 or COM 4 is not available as a free port, the ports will need to be reconfigured in the computer's device manager. Go to *Control Panel\System\Hardware* and select *Device Manager*. Select *Ports* and reassign the alternate port or the USB to Serial Adapter to COM1, COM3 or COM 4. For laptops using a USB adapter, select COM4 or an alternate COM port as necessary.

Calibration

1. Connect a serial download cable (P/N 90840A004) from the PC serial port to “COM2” (J10 on the Main Board).

COM2

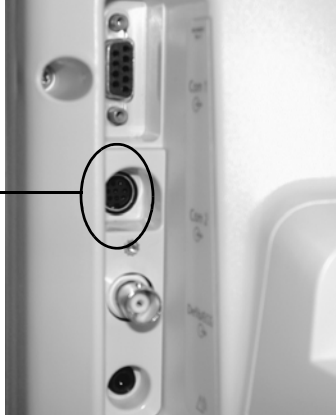

2. Open the service tool on the computer. Select *Start > Programs > CSI NIBP Service > NIBPSvc*. Close the disclaimer dialogue box.
3. Select *COM1* for the port and select *8100 Integrated NIBP* for the model. Click on *OK*.
4. Click on *Connection* and select *Open in Service Mode*.
5. Press the nGenuity 8100E monitor ON/OFF key to start the monitor.
6. Connect a 700cc dummy cuff and manometer to the NIBP fitting on the unit.

7. Click on the *Calibrate* button to calibrate the NIBP module.

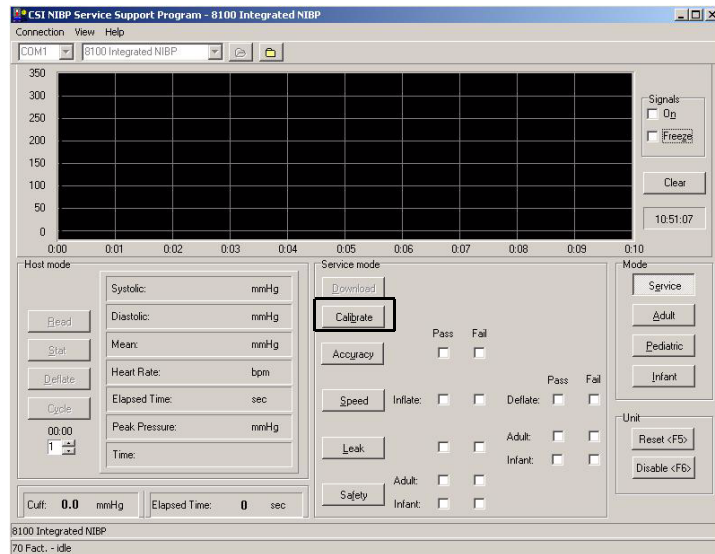

Figure 6-5: Select Calibrate

8. A box prompting you to attach the digital manometer and dummy cuff will appear. Verify that the pressure at the cuff is “0mmHg” \pm 2mmHg. Click *Next*.

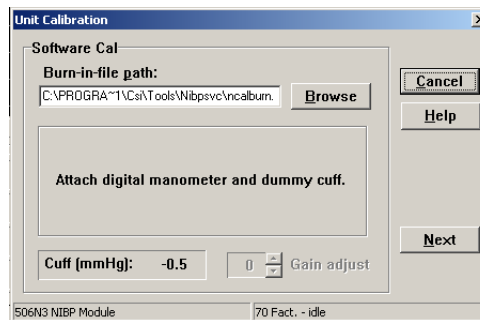

Figure 6-6: Verify Cuff Pressure

9. Verify that the pressure at the cuff is “0mmHg” ± 2 mmHg. If the pressure is not ± 2 mmHg of zero, the main board must be replaced. Click *Next*.

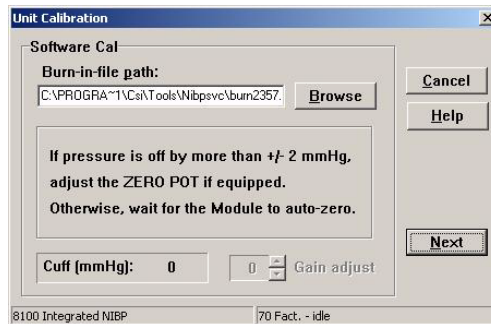

Figure 6-7: Verify Cuff Pressure

10. Check the cuff pressure as indicated on the service screen of the computer with the pressure indicated on the digital manometer. The cuff pressure should be within ± 0.5 mmHg of each other. Use the up and down arrows to adjust the gain unit until the pressures match each other. Click *Finish*.

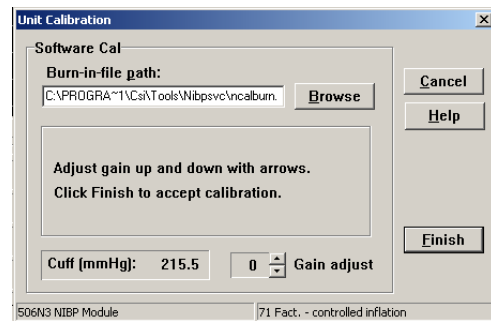

Figure 6-8: Finish Calibration

11. A window will appear on the screen indicating that data is being stored.

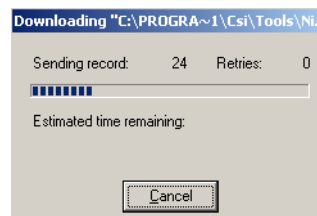

Figure 6-9: Storing Data

12.A *Positive Confirmation* message will appear. Click *Done*.

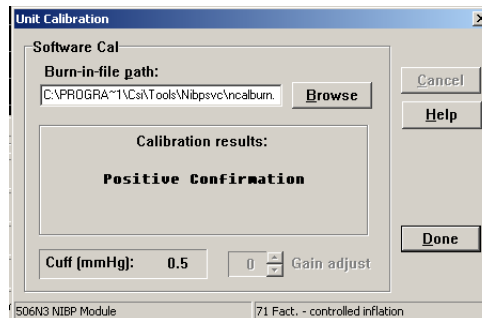

Figure 6-10: Positive Confirmation Message

NOTE: If a confirmation fails, power cycle the monitor and recalibrate.

If the zero base point is out of range, manually set the NIBP module.

NIBP Performance

1. Restart the service program on the PC. Select *Start > Programs > CSI NIBP Service > NIBPSvc*. Close the disclaimer dialogue box.
2. Turn the monitor's power on again and establish a new communications link between the monitor and the PC service program.
3. To perform the service test for speed, click on the *Speed* button, then click on *Start*. When the unit passes the speed test, press *Done*.
4. To perform the service test for leakage, click on the *Leak* button, then click on *Start*. When the unit passes the leakage test, press *Done*.
5. To perform the service test for inflation safety, click on the *Safety* button, then click on *Start*. When the unit passes the safety test, press *Done*.
6. Turn the monitor off. Click on *Abort* if an error message appears on the computer once the monitor is off.
7. Exit the service program on the computer. Remove the download cable. Click *No* to exit the program; click *Yes* to save the data to a user-specified location.

Temperature Input Check

1. Connect the temperature simulator (TP400) to the TEMP connector.
2. Verify the Temperature on the display is within ± 0.1 C for temperature simulator settings of 20, 25, 30, 35, 36, 37, 38, 39, 40, and 45C.
3. Disconnect the Temperature simulator from the TEMP CONNECTOR and verify that the Temperature on the display is "---. -". Verify *TEMP INVALID* appears on the display.
4. Repeat steps 1-3 for temperature simulator (TP700).
5. Switch off the power. Disconnect all cables.

Monitor Fault Testing

The following procedures are used to determine whether boards and assemblies are damaged. New boards and mechanical assemblies should be tested as part of any replacement repair.

Board level tests require opening the monitor housing which can void your product warranty.

Always follow ESD precautions when performing these procedures.



DANGER

- High Voltage! Board testing requires working with dangerous voltages. The rear assembly, that contains the power supply module, should only be serviced by experience electrical technicians.

Power Supply Board Test

1. Remove the batteries from the monitor.
2. Open the case.
3. Follow the disassembly procedures (refer to “Disassembly” in Section 7 in this manual) to expose the power module. Do not remove the power module.
4. Disconnect the DC power cable at PS2 of the Main Board. Leave the other end attached to the Power Supply Board.
5. Using a controlled AC source, apply 115 VAC at 60 Hz to the AC receptacle. The source should be able to supply a minimum of 3 amps. (Use a power cable that has suitable connections to the AC source.)
6. Measure the DC power cable end. The power module should supply 15.3 VDC ($\pm 0.1V$).
7. Proceed to the next step if the voltage is within specification. If it is a new board under test, it might not be calibrated. The trim potentiometer on calibrated boards should be varnished or otherwise sealed.
8. Reassemble the monitor.

Main Board Testing

Test the following conditions without batteries in the monitor.

1. Connect a 15.3VDC 3A power supply to connector PS2 on the Main Board.
2. Insert an ammeter inline at PS1 on the Main Board.
3. Verify the quiescent current (the power is applied, but the power control is in the OFF state) is less than 1ma. This quiescent current decreases to less than 1ma in a very short period of time. This must be done at the Battery connector. Remove the ammeter.
4. Connect a speaker to J20 on the Main Board.
5. Connect a membrane switch to J7 on the Main Board.
6. Attach a menu knob to the main board at J8 on the Main Board.
7. Verify that the monitor turns on after pressing the ON/OFF key, and that the following voltages are present:

Test Point	Signal	Value
TP21	+PWRUNSW	+15.3V (±0.5VDC)
TP4	+5D	+5.0V (±0.1VDC)
TP18	+5P	+5.0V (±0.1VDC)
TP1	+3.3D	+3.3V (±0.05VDC)
TP17	+8V	+8.0V (±0.25VDC)
TP7	-5A	-5.0V (±0.25VDC)
T13	+6.8	+6.8V (±0.32VDC)
TP9	+5A	+5.0V (±0.3VDC)
TP14	+5VREF	+5.0V (±0.025VDC)
TP3	+5B	+5.0V (±0.25VDC)

Section 7 — Disassembly

Before You Begin

Tools Needed The following tools are needed to perform these procedures:

- #0 phillips screwdriver
- #1 phillips screwdriver
- #2 phillips screwdriver
- 3/16 flat blade screwdriver
- 11mm deep dish socket and wrench

Before You Begin

1. Turn the monitor off.
2. Disconnect the AC (Mains) power cord and remove the battery.

WARNING

- The procedures presented in this section are intended to be implemented by qualified biomedical engineering or field service personnel for PCB assembly replacement.
- The procedures presented in this section are not intended to be used for component-level trouble shooting and repair of the PCB assemblies. Only CSI service personnel are authorized to perform component-level repair.
- Possible safety hazard. Read the battery safety information provided in “Safety” on page 1-16

CAUTION

- Opening a monitor and breaking the quality seal can void your manufacturer warranty! Before breaking the seal on a CSI monitor, contact the CSI service department.

The repair procedures for the monitor are included here for the determination of damaged or unusable assemblies. CSI does not recommend attempting the field repair of the circuit boards.

Service Safety

DANGER

- The monitor contains an internal AC power supply that contains potentially lethal voltages.
- High Voltage! If the power supply is defective, replace the entire Power Supply assembly.

Electrostatic Discharge Protection



The procedures in this section require handling of electrostatic sensitive components. Microprocessors and other electronic components can be permanently damaged by attempting repairs at an unprotected workbench.

Use all electrostatic discharge (ESD) protection as described!

- Perform the disassembly procedure on an antistatic mat that is grounded. Check the ground cable to insure that it is connected to a good earth ground.
- Use a grounded soldering iron.
- Wear a wrist-grounding strap.
- Connect the wrist strap and mat through a resistor (1 megohm typical) to the same ground source.
- Test the wrist-ground straps on a daily basis.
- Temporarily store components in metal or antistatic containers. Do not store components in plastic dishes. Store circuit boards in sealed antistatic bags or cover them in antistatic boxes. Do not store electronic boards directly in cardboard boxes.

Disconnecting and Replacing the Battery

Remove the Battery

1. Follow all ESD procedures as stated in “Electrostatic Discharge Protection” on page 7-2.
2. Remove the two (2) screws (PHMS 4-40 x .500 SEMS; pn 40995B003) from the battery door.
3. Remove the battery door (pn 45182B001) from the rear monitor enclosure (pn 45179B001).
4. Unscrew battery bracket (pn 42634B002).
5. Label and remove the battery cables from the battery.

Reconnect or Replace the Battery

1. Connect the battery cable to the battery:
 - Negative lead (black) to the negative (-) terminal of the battery
 - Positive lead (red) to the positive (+) lead of the battery.
2. Replace battery bracket.
 - Wires must not route between battery and bracket.
3. Place the battery door (pn 45182B001) onto the rear enclosure (pn 45179B001).
4. Insert the two (2) screws (PHMS 4-40 x .500 SEMS; pn 40995B003) into the battery door and secure.

Printer Repair

- | | |
|-------------------------------|---|
| Removing Printer Assembly | <ol style="list-style-type: none">1. Follow all ESD procedures as stated in “Electrostatic Discharge Protection” on page 7-2.2. Remove the battery following the instructions in “Remove the Battery” on page 7-2.3. Remove the two (2) screws (PHMS 4-40 x 0.312 SEMS; pn 40995B001) holding the printer assembly (pn 92804A001) to the monitor.4. Label and remove the ribbon cable from the printer module.5. Remove the module from the main monitor assembly. |
| Replacing Printer Components | <ol style="list-style-type: none">1. Remove the three (3) screws (pn 40995B005) holding the Printer PCB to the assembly.2. Disconnect Ribbon Cables J2 and J3.3. Remove the Printer PCB (pn 91341A003) and set on an ESD-safe mat. If only the Printer PCB needs to be replaced, go to step #4.4. If the print head needs to be replaced:<ol style="list-style-type: none">a. Remove the three (3) screws (pn 41458B001) and the two (2) brackets (pn 45188B001 and pn 45189B001) holding the print head in place.b. Remove the print head (pn 84005B001).c. Place the new print head into the printer assembly.d. Reattach Ribbon Cables J2 and J3.e. Reattach the brackets with the three (3) screws removed earlier.5. Place Printer PCB in the assembly and fasten with the three (3) screws removed earlier. |
| Reattach the Printer Assembly | <ol style="list-style-type: none">1. Position the printer module assembly (pn 92804A001) over the main monitor assembly.2. Connect the ribbon cable to the printer module and insert the module into the main monitor assembly with etch facing PCB.3. Insert the two (2) screws (PHMS 4-40 x 0.312 SEMS; pn 40995B001) and secure. |

Front Main Chassis Repair

Disassembly

1. Remove and retain encoder knob from front unit by rotating and prying the knob off.
2. Remove and retain four (4) nylon screws (pn 42654B002) and clear plastic insulator (pn 40083B002) from bottom of unit.
3. Remove and retain two (2) phillips flat head screws from bottom of unit.
4. Remove and retain two (2) phillips flat head screws from rear of unit near power entry module.
5. Remove and retain two (2) phillips pan head screws and battery cover from rear of unit battery cover.
6. Remove and retain two (2) phillips pan head screws and either printer or printer cover from rear of unit.
7. Disconnect printer cable from printer.
8. Remove and retain six (6) phillips head screws from around edge of unit accessible from rear of unit.
9. Remove quality sticker from the unit.

PCB Replacement

SpO₂ PCB

To replace the SpO₂ PCB assembly (pn 91339A001):

1. Label and disconnect the connectors at P1 and J1 on the SpO₂ PCB.
2. Remove the four (4) screws (PHMS 4-40 X 0.500; pn 40995B003) holding the SpO₂ PCB to the chassis assembly.
3. Remove the SpO₂ PCB from the mounting plate (pn 42636B001).
4. Position the new SpO₂ PCB over the bracket and connect it to the SpO₂-to-analog cable at P1.
5. Reattach the SpO₂ cable to the SpO₂ PCB at J1.
6. Place the SpO₂ PCB on the SpO₂ mount plate.
7. Secure the SpO₂ PCB to the mount plate with the four (4) screws removed earlier.

SHIELDED ANALOG PCB

To replace the Shielded Analog PCB (pn 91353A003):

1. Remove the SpO₂ PCB assembly as described in “SPO2 PCB” on page 7-4.
2. Label and disconnect all connectors. Remove four (4) screws from the corners of the metal plate which the SpO₂ Board is mounted on. Remove the plate.
3. Remove the four (4) spacers (pn 40909B002) that hold the shielded analog PCB assembly.
4. Disconnect cables from P1 (ECG Cable) and P5 (Ribbon to SpO₂ Board).
5. Remove the Shielded Analog PCB.
6. Reassemble in reverse order.
 - Be certain when installing the Shielded Analog PCB that P4 is fully seated to the main PCB.
 - If not seated properly, the unit will display a *CONM H/W* error shortly after Power Up.

MAIN PCB

To replace the Main PCB (pn 91340A004):

1. Remove the four (4) screws (PHMS 4-40 X 0.312 SEMS; pn 40995B001) that hold the chassis to the front enclosure. Remove the monitor chassis assembly (pn 92803A001) from the front enclosure.
2. Label and disconnect all connectors from rear Main PCB.
3. Remove the two (2) screws (PHMS 6-32 x 0.500; pn 40496B004) and standoffs (F/F 6/32 X 0.625 HEX; pn 42639B001) from the upper section of the main frame and the upper section of the Main PCB. Retain the screws and standoffs for reassembly.
4. Remove the four (4) screws (PHMS 6-32 X 0.250; pn 40496B002) and the four (4) standoffs (F/F 6/32 X 0.625 HEX; pn 42639B001) from the middle and lower sections of the main frame and the Main PCB. Retain the screws and standoffs for reassembly.
5. Remove the Main PCB shield (pn 45192B001) from the main frame (pn 42635B001).
6. Label and disconnect all connectors from front (Display) of main PCB.
7. Remove the Main PCB from the shield.
8. Reassemble in reverse order.

Display Assembly

Display Removal

1. Follow all ESD procedures as stated in “Electrostatic Discharge” in this section.
2. Remove the battery following the instructions in “Remove the Battery” described in this section.
3. Remove the front main chassis as described previously in this section.
4. Remove the four (4) screws (PHMS 4-40 X 0.312 SEMS; pn 40995B001) that hold the chassis to the front enclosure. Remove the monitor chassis assembly (pn 92803A001) from the front enclosure.
5. Remove the four (4) screws (pn 40995B006) that hold the display to the assembly. Tilt display forward and disconnect all connectors.
6. Remove the Display assembly from the front chassis.

Membrane Replacement

1. Remove the rotary encoder shaft using 11mm wrench.
2. Carefully press the membrane switch from the chassis. Retain silicone tubing from membrane studs.
3. Position the membrane switch (pn 45177B001) over the display chassis (pn 42637B001). Align the four (4) threaded studs on the membrane switch with the four (4) holes on the display chassis. Push on the membrane switch and place silicone tubing onto the four (4) threaded studs.
4. Slide the encoder shoulder washer (pn 42640B001) onto the rotary encoder (pn 42140B001). Insert the rotary encoder through the rear of the display chassis so that it protrudes through the membrane switch.
5. Slide the encoder flat washer (pn 42641B001) onto the rotary encoder.
6. Place and secure the lock washer and the nut, which is part of the rotary encoder onto the encoder.
7. Reassemble the monitor.

Display Installation

1. Attach the four (4) pieces that make up the foam gasket (pn 43614B001) to the display (pn 81520B001).
2. Align the new display over the stand offs of the display chassis. Secure the new display with four (4) screws.

Bottom Chassis Repair

- Disassembly
1. Follow all ESD procedures as stated in "Electrostatic Discharge Protection" in this section.
 2. Remove the battery following the instructions in "Remove the Battery" in this section.
 3. Remove the two (2) screws (PHMS 6-32 X 0.375 SEMS pn 40180B002) from the rear enclosure (pn 45179B001). Refer to "Front Chassis Disassembly" earlier in this section.
 4. Remove the rear enclosure (pn 45179B001) from the front enclosure assembly (pn 45178B001).

- Speaker Replacement
1. Label and disconnect the speaker wire from J20 on the Main PCB.
 2. Remove the speaker assembly (pn 95257A002) and the speaker mounting plate (pn 42633B001) from the chassis bottom.
 3. Position and place the speaker assembly over the speaker insulator.
 4. Position and place speaker mounting plates (pn 42633B001) onto chassis speaker studs.
 5. Secure speaker with 6-32 keps nuts (pn 40284B002).
 6. Attach the speaker wire to J20 on the Main PCB.

- NIBP Chassis Replacement
1. Label and remove the hoses from the NIBP fitting and Main PCB. Disconnect cable from Main PCB (P2).
 2. Remove the four (4) screws (PHMS 4-40 X 0.250 SEMS; pn 40995B005) holding the NIBP chassis to the bottom chassis.
 3. Remove the NIBP chassis.
 4. Position and place the new NIBP chassis assembly (pn 92797A001) onto the four (4) stand-offs of the riveted bottom chassis assembly (pn 92798A001).
 5. Secure the NIBP chassis assembly with four (4) screws removed earlier.
 6. Reattach connector P2 on the Main PCB and hoses on Main PCB and NIBP fitting.

- Power Supply Replacement
1. Label and disconnect the power supply cable from PS2 on the Main PCB.
 2. Disconnect cable CN1 from power supply.
 3. Disconnect groundwire from JP1 and Power Supply.

4. Remove the two (2) screws (PHMS 6-32X0.25 SEMS; pn 40496B002) from the bottom of the chassis that hold the power supply bracket in place. Disconnect cable from J5.
5. Remove the existing power supply from the chassis. Connect cable to J5 on new Power Supply.
6. Position and place the new power supply onto the riveted bottom chassis assembly (pn 92798A001).
7. Insert the two (2) screws removed earlier through the bottom of the chassis and into the power supply bracket. Secure the assembly with the screws.
8. Attach the power supply cable to J20 on the Main PCB.
9. Attach ground wire to JP1 on Power Supply.
10. Attach power cable to CN1 on Power Supply.

Testing

Perform the annual safety tests and the electrical safety tests any time the monitor is opened for repair. These tests are found in "Preventative Maintenance" in Section 5.

Assembly Tests

Field Service Assembly Testing		
Unit Serial Number _____ Main Software Revision _____		
	<u>Pass</u>	<u>Fail</u>
Plug an AC cord into the unit.		
The green AC light should be on.	_____	_____
Hit the Power key.		
The display should show CSI with current revision of software.	_____	_____
Check for proper operation of pump by hitting the "NIBP" key.		
To insure the membrane buttons are operable, hit the following keys in sequence and listen for the beep:		
FREEZE	_____	_____
NIBP CYCLE/STAT	_____	_____
NIBP	_____	_____
PRINT	_____	_____
SILENCE	_____	_____
DEFAULT	_____	_____
TREND	_____	_____
STANDBY	_____	_____
Rotate the Encoder knob and verify the cursor moves.		
	_____	_____
Press the encoder and verify a menu is selected.		
	_____	_____
Press the encoder again to exit.		
	_____	_____
List of replaced or repaired modules:		
Description		Serial Number
_____		_____
_____		_____
_____		_____
_____		_____
_____		_____
Certification of Proper Assembly		
Name _____		Date _____
Assembly Technician		
Name _____		Date _____
This checklist may be copied.		

Section 8 — Troubleshooting

This section lists the possible causes of monitor problems. Use this table and the schematics in “Drawings and Schematics” in Section 9 to identify and locate components that malfunction.

Symptom	Problem	Solution
Unit won't power up (On/Off LED is dark)	<ul style="list-style-type: none"> Battery is not connected Battery is discharged AC power cord is not securely connected to monitor AC outlet off or unpowered Fuses are blown (Located below AC connection) Main Board is disconnected Bad membrane Main Board fuse blown 	<p>Fully seat battery connection Connect AC power cord Connect AC power cord to monitor</p> <p>Connect power cord to a live outlet Replace AC fuses (pn 80131B002)</p> <p>Reconnect DC power cable at PS2 on Main Board Replace the keypad membrane Replace F2 on Main Board for battery or F4 for Power Source</p>
Cannot activate hardkey function or turn on monitor with AC power (On/Off LED is green)	<ul style="list-style-type: none"> Membrane panel is not securely connected Keypad membrane is bad Inverter is bad Main board is bad 	<p>Reconnect ribbon cable to J7 on Main Board Replace keypad membrane panel Replace the inverter Contact CSI Service Department</p>
Display is blank or not readable	<ul style="list-style-type: none"> Video screen cables to Main Board are disconnected or loose Inverter malfunction Inverter is bad 	<p>Reconnect data and inverter cables to connectors on Main Board (J2, J3, J4, and/or J5) Make sure all Inverter connections are secure. Replace the inverter</p>
NIBP air leak	<ul style="list-style-type: none"> Defective cuff Defective hose Pneumatic tube leaks Defective valve Defective main board 	<p>Replace Cuff Replace Hose Re-seat tube or replace pneumatics Contact CSI Service Department Contact CSI Service Department</p>
NIBP not functioning	<ul style="list-style-type: none"> Pump disconnected Pump motor failure Main Board pump driver bad NIBP calibration error 	<p>Reconnect pump to P2 on Main Board Contact CSI Service Department Contact CSI Service Department Contact CSI Service Department</p>

Symptom	Problem	Solution
SpO ₂ not functioning	<ul style="list-style-type: none"> SpO₂ Board disconnected Defective SpO₂ Cable ECG S1 switch set wrong Main board malfunction 	Reconnect to P5 on ECG/Analog Board and check the connection at P1 on SpO ₂ Board Replace cable Adjust switches to correct module (1-4 OFF for DOX SpO ₂) Contact CSI Service Department
ECG noise or intermittent function	<ul style="list-style-type: none"> Poor electrode placement Bad/wrong ECG Cable Line Frequency/Filter wrong ECG connection worn Cable to ECG/Analog Board bad Defective analog PCB 	Reposition/replace electrodes Replace ECG cable Check ECG settings Replace ECG port Replace cable assembly at P1 on ECG/Analog Board Replace Analog board
SpO ₂ is “noisy”	<ul style="list-style-type: none"> Sensor may be bad. Receptacle may be damaged. The connection between Main Board J12 and ECG/Analog Board P4 is loose or disconnected. (Can be verified by presence of CONM H/W error.) Main Board or ECG/Analog Board may be bad. 	Replace the sensor. Replace receptacle. Reseat the connection. Replace Board(s)
No sound from speaker	<ul style="list-style-type: none"> Volume turned down Main Board connection is disconnected or loose Speaker wire broken at speaker terminals 	Set volume higher in Configuration (CONFIG) window. Reconnect J20 on Main Board Check speaker wires for breaks or bad crimp pins
Speaker scratchy or unclear sound	<ul style="list-style-type: none"> Metal debris on speaker Bad speaker 	Remove debris from speaker drum Replace speaker
COM 1 serial interface doesn't work	<ul style="list-style-type: none"> Set to internal printer Incorrect or bad cable Setting mismatch Connector is bad 	Reset monitor to external printer Replace with correct serial cable Reset baud rate and other settings Replace the Main Board
No ECG trace displays	<ul style="list-style-type: none"> ECG Cable may be bad. The connection between Main Board J12 and ECG/Analog Board P4 is loose or disconnected. (Can be verified by presence of CONM H/W error.) Main Board or ECG/Analog Board may be bad. 	Replace with known good cable. Reseat the connection. Replace Board(s)

Troubleshooting and Repair

Before attempting to repair a damaged monitor the technician must fully understand the functions of the monitor. The service technician should have read and understood all the previous sections of this manual.

You must fully repair, calibrate, and test all damaged monitors before you use them on patients. The monitor must meet the original operating specifications before you use it on a patient.



Always follow ESD precautions when performing any of the procedures discussed in this section.

ComfortCuff NIBP Module

The NIBP module consists of a pneumatic pump assembly (pn 95576A003) and control circuitry located on the Main Board (pn 91340A004).

The pneumatics assembly is mounted on the back side of the metal chassis plate. A large diameter tube (pn 41602B001) connects to the Quick-Connect hardware fixture and the transducer on the Main Board. The transducer port faces out the back side of the Main Board through a hole.

The remaining pneumatics links connect the two control valves (pn 95596A004), the pump (pn 95576A005), and the check valve (pn 41579B003). As the tubing ages it may lose its seal. Old tubing can be re-seated or replaced as necessary.

When any major pneumatic component such as a pump or valve is replaced, the NIBP module must be re-calibrated as in “NIBP Calibration” in section 6 of this manual. The manufacturer recommends that the monitor be returned to a CSI authorized service facility if pump replacement is required.

The transducer SENS1 and the zero point calibration pot R92 are not field serviceable components. Improper replacement can result in permanent damage to the Main Board.

ECG/Impedance Respiration Module

The ECG circuitry is located on the ECG/Analog Board assembly (pn 91353A003) that is attached to the metal chassis behind the main board.

The ECG/Analog Board fits directly on to the Main Board through a socketed 10-pin connection on the left side of the board assembly. There is also a shielded cable assembly that extends from the top of the board to the external ECG port. Check each of these connection points if the monitor fails to produce an accurate ECG waveform.

The ECG/Analog Board has a foil shield to reduce noise from other portions of the monitor. Noise can be introduced by worn cable assemblies and degraded power supplies. Test the analog ECG waveform signal and the input power where they enter the ECG/Analog Board for interference noise.

There is a replaceable 2-amp fuse (pn 80004B003) at location F1 on the ECG/Analog Board. The fuse provides protection in the power circuit leading from the P4 connection to the Main Board. Surface mount components on the ECG/Analog Board are not recommended for field repair and replacement.

You can replace the ECG/Analog Board assembly as a serviceable component. Replacement ECG/Analog Board assemblies, (pn 91353A003) are pre-tested, software loaded, and calibrated. The monitor requires complete safety testing after reassembly.

NOTE: Always check line frequency, filter settings and the ECG lead cables as part of any ECG trouble shooting. Always use the recommended simulators for performance testing.

Board Settings and Module Software

There are three pots under the shielding at locations R112, R110, and R108. They are the baseline adjustments for ECG I, ECG II, and ECG V respectively. These are factory set; you should not adjust them. Set the S1 switches (off) in the open position to allow communication with the DOX module. See “ECG Verification” in Section 5.

The ECG/Analog Board contains its own on-board software that is factory loaded. The program is stored in non-volatile memory on the ECG/Analog Board. Repair or improper handling of the ECG/Analog Board can corrupt this software.

Respiration

The respiration circuit is located on the ECG/Analog Board. There is no separate calibration or testing for the impedance respiration.

Temperature

The temperature module is located on the ECG/Analog Board. There are no on-board settings or service calibrations. The temperature module is auto-calibrating upon start-up.

DOX SpO₂ Module

The DOX SpO₂ module consists of a separate board that is attached above the ECG/Analog Board. There is a communication connection for a ribbon cable (pn 90866A001) at the bottom edge of the ECG/Analog Board. The ribbon cable extends to the SpO₂ Board. There is also a short cable to the ECG/Analog Board (pn 90866A002).

The plethysmograph input signal enters the SpO₂ Board through a shielded cable that runs between the boards and metal chassis to the opposite side of the monitor.

The DOX SpO₂ module is composed of digital components that are not effected by noise. There is also no signal degradation or loss of calibration due to analog components. Interference or noisy signal can be due to a worn cable assembly or DB-9 connector. Replace the connector and cable assembly if necessary.

Always check the sensor when intermittent problems are reported. Stretched or otherwise damaged sensor cables must be replaced.

NOTE: The line frequency setting of the monitor must be set correctly for optimal SpO₂ monitoring.

Main Board

The Main Board (pn 91340A004) contains the primary processors, storage memory, NIBP circuitry, communication interfaces, audio driver, vital signs module connections, power regulation, battery charge circuits, video generation, and keypad inputs (User I/O).

The Main Board has an adjustable pot R92 that you set during NIBP calibration. There are two CPUs on the Main Board that you must program from a CSI Service Download Station. The programmable settings remain in non-volatile memory. Repair or improper handling of the Main Board can corrupt this software.

There is one (1) replaceable 3-amp fuse (pn 82004B001) for the battery input at PS1. There is one (1) replaceable 4A fuse (pn 82004B010) for the power supply module at PS2 (F4 protects the supply output).

If you replace the Main Board you are required to cal-check the NIBP module. NIBP pneumatics assemblies and Main Boards may not be changed unless re-calibrated.

Except for fuses, the Main Board is not a field-repairable component. Replacement Main Boards are pre-tested, programmed, and calibrated.

Power Module

The power module (pn 95710A002) consists of the battery compartment bulkhead and chassis, the fan, cable assemblies, and the Power Supply Board. The Power Supply Board (AC to DC converter) is not a field-repairable component. If the board is damaged or fails test replace the entire assembly.

DANGER



- High Voltage! Repairing and testing the power supply requires working with dangerous voltages. The power supply module should only be serviced by experienced electrical repair technicians.

Fuse Replacement

The main fuses (pn 82013B002) for the power module is located in an external compartment above the AC power cord connection. Replace only with:

- 1A/110/230 volt Time-Lag fuses (pn82013B002).

Check the monitor ID label to determine which voltage the unit uses.

You do not have to open the monitor case to change the main power fuses. See “Fuse Removal/Replacement” in Section 5.

WARNING



- Shock hazard! Substitution of fuses or jumping the fuse contacts can endanger the patient and damage the monitor.

AC Power Components

The power entry module (pn 80243B002), when replaced, must remain electrically isolated between the chassis and power entry module ground. The AC power entry module requires a fuse drawer (pn80130B001).



Replace broken, cracked, or loose AC receptacles. Replace the receptacle if the external pins are bent or broken. Do not attempt to remove or modify the ground pin!

Check the cables and chokes for heat damage before power module replacement. Remove the assembly from the housing and inspect the back side of the board for scorching or damaged solder connections. Replace the entire assembly if there are any signs of high current damage.

Section 9 — Drawings and Schematics

List of Drawings	Title	Drawing Number
Assembly BOMs and Drawings	Final Assembly 8100E (without printer)	93979A001
	Final Assembly 8100EP (with printer)	93979A002
	Final Assembly 8100E1 (w/ CO ₂ , no printer)	93979A011
	Final Assembly 8100EP1 (w/ CO ₂ and printer)	93979A012
	Main Monitor Assembly	92800A001
	Main Monitor with CO ₂ Assembly	92800A002
	Chassis Assemblies	92803A001
	Bottom Chassis Assembly	92799A001
	Power Supply with Brackets	95710A003
	Main Chassis Assembly	92801A001
	NIBP Chassis Assembly	92797A002
	CO ₂ Internal Module Assembly	92811A001
	CO ₂ External Module Assembly	92811A002
	Display Chassis Assembly	92802A001
	Assembly Patient Connectors	95767A001
	Shielded Analog Board Assembly	91353A003
	Printer	92804A001
	PCB Drawings and Schematics	Title
Main Board 8100E/8100EP		91340A005
Main Board 8100E/8100EP Schematic		91340S005
Analog Board 8100		91342A003
Analog Board 8100 Schematic		91342S003
SpO ₂ Board		91339A001
SpO ₂ Board Schematic		91339S001

Final Assembly

8100E (Without Printer) 93979A001 FINAL ASSEMBLY 8100E

Item #	CSI Part #	Description
01	92800A001	AY MAIN MONITOR
02	45183B001	COVER NO PRINTER
03	40995B001	P.H.M.S. 4-40X.312 SEMS
05	95773A001	LABEL SET 8100E/EP ENGLISH
06	41891B002	DB9 COVER PLATE
07	41891B003	PLATE COVER MINI-DIN
08	40123B004	P.H.M.S. 4-40X.250 NY WHT
09	46162B001	LABEL CSI MON BAR CODE
10	46426B004	LABEL HARDWARE REVISION 4

8100EP (With Printer) 93979A002 FINAL ASSEMBLY 8100EP

Item #	CSI Part #	Description
01	92800A001	AY MAIN MONITOR
02	92804A001	AY PRINTER MODULE
03	40995B001	P.H.M.S. 4-40X.312 SEMS
04	40065B002	PAPER THERMAL 2.283 WIDE
05	95773A001	LABEL SET 8100E/EP ENGLISH
06	41891B002	DB9 COVER PLATE
07	41891B003	PLATE COVER MINI-DIN
08	40123B004	P.H.M.S. 4-40X.250 NY WHT
09	46162B001	LABEL CSI MON BAR CODE
10	46426B004	LABEL HARDWARE REVISION 4

8100E1 (With CO₂) 93979A011 FINAL ASSEMBLY 8100E1

Item #	CSI Part #	Description
01	CAT 8100E	NGENUITY MONITOR
02	92811A001	CO2 MODULE AY NGENUITY
03	92811A002	CO2 MODULE AY EXTERNAL 8100E/P
04	40496B001	P.H.M.S. 6-32X.375 SEMS
05	42431B009	STANDOFF M-F 6-32 X 1.25
06	40284B002	NUT 6-32 KEPS PL
07	46547B001	LABEL SERIAL NUMBER ENG
08	46162B001	LABEL CSI MON BAR CODE
09	46426B004	LABEL HARDWARE REVISION 4
10	46599B001	LBL DEFIB SYMBOL

8100EP1 (With CO₂
and Printer) 93979A012 FINAL ASSEMBLY 8100EP1

Item #	CSI Part #	Description
01	CAT 8100EP	NGENUITY MONITOR WITH PRINTER
02	92811A001	CO2 MODULE AY NGENUITY
03	92811A002	CO2 MODULE AY EXTERNAL 8100E/P
04	40496B001	P.H.M.S. 6-32X.375 SEMS
05	42431B009	STANDOFF M-F 6-32 X 1.25
06	40284B002	NUT 6-32 KEPS PL
07	46547B001	LABEL SERIAL NUMBER ENG
08	46162B001	LABEL CSI MON BAR CODE
09	46426B004	LABEL HARDWARE REVISION 4
10	46599B001	LBL DEFIB SYMBOL

Main Monitor Assembly 92800A001 AY MAIN MONITOR

Item #	CSI Part #	Description
01	92803A001	AY CHASSIS MONITOR
02	45178B001	ENCLOSURE FRONT
03	92810A001	AY REAR ENCLOSURE 8100EP
04	42127B005	WINDOW FILTER 8100E
05	87285B001	INSERT EXTERNAL CONNECTORS
06	87277B002	FOOT 7/16 OD X 5/32 HIGH
09	45182B001	BATTERY DOOR
10	42141B002	KNOB ROTARY ENCODER CUSTOM
12	42431B011	STANDOFF M-F 6-32 X 1.5
14	40995B001	P.H.M.S. 4-40X.312 SEMS
15	40995B003	P.H.M.S. 4-40X.500 SEMS
16	40496B001	P.H.M.S. 6-32X.375 SEMS
17	40180B002	F.H.M.S. 6-32X.375 PL PH
18	40083B002	F.H.M.S. 8-32X.375 PH PL
19	42731B001	P.H.M.S. 8-32 X .5 PL INTERNAL SEM PHILLIPS
21	40067B001	CABLE TIE 4.0
22	83338B002	DISPLAY FILM
23	42115B001	SCREW FH #4X3/8 HI-LO PH
24	42431B007	STANDOFF M-F 6-32 X 7/8
25	41955B001	FOAM TAPE 1.0 X 2.12
26	40067B003	CABLE TIE 8
27	40294B001	HOLDER TIE WRAP ADH-BK SM
28	42634B002	BRACKET BATTERY LOCK
29	42643B002	FOAM PAD BATTERY
30	80519B001	BATTERY, SLA 12V, 5AHR
31	40283B002	WASHER FLAT #4 NY .032

Main Monitor with CO₂ Assembly 92800A002 ASSEMBLY MAIN MONITOR W/CO2

Item #	CSI Part #	Description
01	92803A001	AY CHASSIS MONITOR
02	45178B001	ENCLOSURE FRONT
03	92810C001	AY REAR ENCLOSURE 8100EP
04	42127B005	WINDOW FILTER 8100E
05	87285B001	INSERT EXTERNAL CONNECTORS
06	87277B002	FOOT 7/16 OD X 5/32 HIGH
07	92811A001	CO2 MODULE AY NGENUITY
08	92811A002	CO2 MODULE AY EXTERNAL 8100E/P
09	45182B001	BATTERY DOOR
10	42141B002	KNOB ROTARY ENCODER CUSTOM
12	42431B011	STANDOFF M-F 6-32 X 1.5
14	40995B001	P.H.M.S. 4-40X.312 SEMS
15	40995B003	P.H.M.S. 4-40X.500 SEMS
16	40496B001	P.H.M.S. 6-32X.375 SEMS
17	40180B002	F.H.M.S. 6-32X.375 PL PH
18	40083B002	F.H.M.S. 8-32X.375 PH PL
19	42731B001	P.H.M.S. 8-32 X .5 PL INTERNAL SEMS PHILLIPS
21	40067B001	CABLE TIE 4.0
22	83338B002	DISPLAY FILM
23	42115B001	SCREW FH #4X3/8 HI-LO PH
24	42431B007	STANDOFF M-F 6-32 X 7/8
25	42431B009	STANDOFF M-F 6-32 X 1.25
26	40284B002	NUT 6-32 KEPS PL
28	42634B002	BRACKET BATTERY LOCK
29	42643B002	FOAM PAD BATTERY
30	80519B001	BATTERY, SLA 12V, 5AHR
31	40283B002	WASHER FLAT #4 NY .032
32	41955B001	FOAM TAPE 1.0 X 2.12
33	40067B003	CABLE TIE 8
34	40294B001	HOLDER TIE WRAP ADH-BK SM

Chassis Assemblies 92803A001 AY CHASSIS MONITOR

Item #	CSI Part #	Description
01	92799A001	AY CHASSIS BOTTOM
02	92801A001	AY CHASSIS MAIN
03	92802A001	ASSEMBLY CHASSIS DISPLAY
08	40496B002	P.H.M.S. 6-32X.250 SEMS
09	40132B001	TAPE MICROFOAM ADH-BACKED
10	SHTM10005	SUPPORT BRCKT NGENUITY
11	40496B001	P.H.M.S. 6-32X.375 SEMS
12	40294B001	HOLDER TIE WRAP ADH-BK SM
13	40067B001	CABLE TIE 4.0

Bottom Chassis Assembly 92799A001 AY CHASSIS BOTTOM

Item #	CSI Part #	Description
01	92798A001	AY CHASSIS BOTTOM RIVETED
02	95710A003	AY POWER SUPPLY WITH BRACKETS
03	92797A002	ASSEMBLY NIBP CHASSIS
04	95257A002	SPEAKER ASSEMBLY
05	90865A003	CBL AY PWR SUPPLY TO MAIN
06	90968A004	CBL AY INLET GROUND
07	95768A001	CABLE AY, BATTERY TO MAIN PCB
08	80243B002	PWR ENTRY MODULE, FILTERED
09	80130B001	PWR RECPT/FUSE DRAWER
10	82013B002	FUSE T TIME LAG 1A L 250V 5X20
12	45193B001	INSULATOR POWER INPUT
13	42633B001	PLATE SPEAKER MOUNTING
14	45187B001	INSULATOR SPEAKER
16	42643B003	FOAM PAD BATTERY
17	41537B001	FOAM DISK 1.38 DIA .25THK
18	41158B001	TERMINAL EQUIPOTENTIAL
19	40995B005	P.H.M.S. 4-40X.25 SEMS
20	40496B002	P.H.M.S. 6-32X.250 SEMS
21	41297B001	F.H.M.S. 4-40X.375 PL PH
22	40284B001	NUT 4-40 KEPS PL
23	40284B002	NUT 6-32 KEPS PL
24	41164B001	NUT M6 X 1.0 KEPS PL
25	42353B001	SHOULDER WASHER #4
26	42448B001	1/4-20 SS316 SPRNG LOCK
27	40500B003	WASHER FLAT #6 NY .062THK
28	40294B001	HOLDER TIE WRAP ADH-BK SM
29	40067B001	CABLE TIE 4.0
30	40067B002	CABLE TIE 5.6
32	42402B002	BATTERY SLIDE 8100EP
33	40132B001	TAPE MICROFOAM ADH-BACKED
34	41955B001	FOAM TAPE 1.0 X 2.12

Power Supply with Brackets 95710A003 AY POWER SUPPLY WITH BRACKETS

Item #	CSI Part #	Description
01	86523B001	POWER SUPPLY 60W
02	42368B002	BRACKET RIGHT PS
03	42369B002	BRACKET LEFT PS
05	40995B003	P.H.M.S. 4-40X.500 SEMS
06	40887B002	SPACER NY #6/.250D/.250L
07	41157B001	THRDLOCK ASSURE SURF CUR
08	42501B002	GROMMET STRIP WITH ADHES
09	42499B002	WASHER CUP NYLON #4

Main Chassis Assembly 92801A001 AY CHASSIS MAIN

Item #	CSI Part #	Description
01	42635B001	FRAME MAIN
02	91340A005	ASSY MAIN PCB 8100E1/EP1
03	91353A003	AY SHIELDED ANALOG BRD
04	91339A001	ASSEMBLY PCB 8100 SPO2 BOARD
05	42636B001	PLATE SPO2 MOUNT 8100E/EP
06	95767A001	ASSEMBLY PATIENT CONNECTORS
07	90866A002	CABLE SPO2 TO ANALOG
08	45192B001	SHIELD MAIN PCB
09	82569B001	FERRITE BEAD
10	42642B001	SPACER MAIN PCB
11	40496B002	P.H.M.S. 6-32X.250 SEMS
12	40496B005	P.H.M.S. 6-32X.750 SEMS
13	42639B001	STANDOFF F-F #6-32 X .625 HEX
14	40909B002	SPCR HEX 6-32X.625 NY M/F
15	41955B001	FOAM TAPE 1.0 X 2.12
16	40067B003	CABLE TIE 8
17	42501B002	GROMMET STRIP WITH ADHES
18	40035B001	TAPE ELECTRICAL BLK .75
19	83111B002	8100 PRINTER CBL
20	40995B003	P.H.M.S. 4-40X.500 SEMS
21	41371B001	TAPE INSUL KAPTON 2

NIBP Chassis Assembly 92797A002 ASSEMBLY NIBP CHASSIS

Item #	CSI Part #	Description
01	95576A005	AY PUMP WITH WIRES
02	95596A004	AY OKEN VALVE WITH CRIMPS
04	42629B001	BRACKET NIBP
06	42081B002	ORIFICE RESTRICTOR .0125
07	42111B001	SCREW M2-.4X3 PH BINDER
08	41700B001	TUBING POLYU .094IDX.1870
09	40296B002	TUBING SILC BLU .125X.250
10	42069B001	TUBING 1/4X1/8 POLYU COIL
11	40294B001	HOLDER TIE WRAP ADH-BK SM
12	40067B002	CABLE TIE 5.6
13	40067B001	CABLE TIE 4.0
14	41955B001	FOAM TAPE 1.0 X 2.12
15	41579B003	CHECK VALVE
16	80111B001	FERRITE BEAD EMI SHIELD
17	40041B022	TUBING SHRINK .75 CLEAR
18	87151B006	HOUS SOCKET .098 LOCKING
20	41157B001	THRDLOCK ASSURE SURF CUR
21	41700B002	TUBE POLYU .125 X .250 85DU
22	40324B009	T CON 3/32 X 3/32 X 1/8
23	40324B015	TEE CONNECTOR, PLASTIC .093 X .125 X .125
24	40325B002	STRAIGHT CONN, 1/8" TO 1/8"
25	40633B001	FILTER 130U RED NY ELEM

CO ₂ Internal Module Assembly		92811A001	CO2 MODULE AY NGENUITY
Item #	CSI Part #	Description	
01	91783A001	AY PNEUMATICS CO2	
02	91784A001	AY PLATE PNEUMATIC RECEPACLES	
03	91407A001	AY PCB CO2	
04	42689B001	CHASSIS CO2 INTERNAL	
05	94254A004	AY PUMP W/CONNECTOR 3 WIRE	
06	41188C201	CO2 DETECTOR	
07	83304B001	GASKET DETECTOR/IR SOURCE	
08	40995B005	P.H.M.S. 4-40X.25 SEMS	
09	40496B002	P.H.M.S. 6-32X.250 SEMS	
10	40496B004	P.H.M.S. 6-32X.500 SEMS	
11	42643B001	FOAM PAD BATTERY	
13	42688B001	FITTING ELBOW 1/8-1/16	
14	41002B002	TYGON TUBING .063 ID X .125 OD	
15	40320B001	TYGON TUBING .125IDX.150D	
16	40887B002	SPACER NY #6/.250D/.250L	
17	42691B001	WASHER, SHOULDER #6, .40 LONG	
18	46597B001	LBL MANIFOLD CONNECTIONS	
19	46598B001	LBL PNEUMATICS RECPTACLES	
20	90903A002	AY CABLES VALVES CO2	
21	40283B002	WASHER FLAT #4 NY .032	
22	40132B001	TAPE MICROFOAM ADH-BACKED	
23	95787A001	ACCULULATOR PVC 11 INCH	
24	40067B003	CABLE TIE 8	
25	90926A002	CABLE AY NIBP TO MAIN BOARD	
26	42155B001	FOAM PAD 8100E PUMP	
27	40496B001	P.H.M.S. 6-32X.375 SEMS	
28	40893B001	WASHER FLAT #8 PL	
29	41371B001	TAPE INSUL KAPTON 2	
30	41557B001	THRDLOCK ASSURE SURF CUR	
31	40067B001	CABLE TIE 4.0	

CO₂ External Module Assembly 92811A002 CO2 MODULE AY EXTERNAL 8100E/P

Item #	CSI Part #	Description
01	45205B001	ENCLOSURE EXTERNAL CO2
02	91785A001	AY PLATE PNEUMATIC PLUGS
03	91782A004	AY MANIFOLD WT W/TRAP DETECT GREY
04	95780A001	AY TRAP DETECT 8100E
06	42686B001	SHOULDER SCREW
07	42687B001	CLIP MANIFOLD
08	41458B001	P.H.M.S. 4 X .250 HI/LO
09	40570B004	ABSORBER IBENCH
10	42299B001	RETAINER TRAP DETECT
11	42300B001	MOUNTING BLOCK TRAP DETECT
12	42064B005	F.H.M.S. 4-40X.500 PH PL
13	41002B002	TYGON TUBING .063 ID X .125 OD
14	42692B001	PAD 1.00 X .25
15	40995B001	P.H.M.S. 4-40X.312 SEMS
16	40596B001	ADHESIVE EPOXY HYSOL E-90FL
17	42496B001	WASHER FLAT #4 BRASS

 Display Chassis Assembly 92802A001 ASSEMBLY CHASSIS DISPLAY

Item #	CSI Part #	Description
01	42637B001	CHASSIS DISPLAY
02	81520B001	LCD ACTIVE TFT 10.4 NEC-59
03	40614B001	DISPLAY CABLE 8100E
04	90859A005	ASY CABLE MAIN BOARD TO INVRTR
05	83265B003	BACKLIGHT INVERTER
06	45177B001	MEMBRANE SWITCH
07	45181B001	BRACKET DISPLAY MOUNT
08	40132B001	TAPE MICROFOAM ADH-BACKED
09	42140B001	ROTARY ENCODER
10	42640B001	WASHER SHIELDED ENCODER
11	42641B001	WASHER FLAT ENCODER
13	43614B001	FOAM GASKET 9.25 x .25 x .060
15	40296B001	TUBING SILC BLU .040X.140
17	40995B005	P.H.M.S. 4-40X.25 SEMS
18	40995B006	#4-40 PHMS SEMS PHILLIPS
21	42652B001	STANDOFF F-F 2-56 NYLON .5 LNG

Assembly Patient Connectors 95767A001 ASSEMBLY PATIENT CONNECTORS

Item #	CSI Part #	Description
01	87284B001	INSERT PATIENT CONNECTORS
02	90860A001	AY CBL 8100 SPO2 TO DB9
03	90872A005	ASSEMBLY CABLE TEMP CONNECTOR
04	42014B001	FITNG, QUICK CON. HH NIBP
06	40284B005	NUT 10-32 KEPS PL
07	41458B001	P.H.M.S. 4 X .250 HI/LO
08	40086B001	WASHER FLAT PL .125X.219
09	90817A005	AY CBL 8100 ECG TO OUT

Shielded Analog Board Assembly 91353A003 AY SHIELDED ANALOG BRD

Item #	CSI Part #	Description
01	91342A003	ASSEMBLY ANALOG PCB 8100
02	41785B004	SHLD ANALOG BRD 8100
03	40995B011	P.H.M.S. 4-40 X .438 SEMS
04	40086B001	WASHER FLAT PL .125X.219
05	83358B001	INSULATOR ECG SHIELD
06	83434B001	CIRCUT BRD ECG SHEILD
07	40284B001	NUT 4-40 KEPS PL
08	40431B001	WIRE 18AWG 300V GREEN/YELLOW
09	40884B001	SPACER #4/.250OD/.125L PL

Printer 92804A001 AY PRINTER MODULE

Item #	CSI Part #	Description
01	45184B001	ENCLOSURE PRINTER
02	45186B001	DOOR PRINTER
03	84005B001	PRINTER SEIKO
04	91341A003	PCB AY SEIKO PRINTER
05	45188B001	BRACKET PRINTER
06	45189B001	BRACKET PRINTER SMALL
07	40418B001	DOWEL PIN .125"D X 2.0"L
08	41458B001	P.H.M.S. 4 X .250 HI/LO
09	40995B005	P.H.M.S. 4-40X.25 SEMS
10	45209B001	INSULATING DOT 1/4 INCH

Appendix A — CO₂ Service

Service Windows

Monitors with CO₂ will have additional items in the *Service Mode* window. The additional items are highlighted below.

```
EXIT
Enter NIBP Service      NO
Enter CO2 Service      NO
Software Download      No action taken
Permanent Alarm Silence Enable
ST / Arrhythmia Keycode ----- Invalid Keycode

Current Software Revisions
  Main Display Processor  Rev 2.0C
  NIBP Processor          Rev 6.6D
  Vital Signs Processor   Rev 6.2A
  CO2 Processor           Rev 0.3B

Unit Serial Number      111111111
Unit Part Number        93979AXXX
Keycode Base Number     00000000
```

Figure A-1: Service Mode Window

```
CO2 Operating Mode      User Mode
CO2 Zero Cal            Abort CO2 Zero Cal
CO2 Gain Adjustment     Turn to Incr/Decr, Press to Save
CO2 Factory Defaults?   No Action
N2O compensation        OFF
```

Figure A-2: CO₂ Service Window

Theory of Operations

Capnometer Module (CO₂) The capnometer contains the circuitry for monitoring the sidestream CO₂ level by actively sampling from the patient's airway. It contains provisions for interfacing with galvanic oxygen monitoring option sub-modules. No electrical connection is made with the patient from the monitor for capnometry. The CONM module controls the capnometer.

The CO₂ Board contains an assembly known as a "bench." This bench contains the optics, IR source, detector, sample cell, and optical filters. The purpose of this bench is to convert CO₂ levels in a gas sample to electrical signals.

The bench assembly utilizes the principle of infrared absorption spectrometry to measure to the amount of CO₂ in patients breath. Infrared absorption spectrometry is widely used in gas analysis. Using a phenomenon explained in "Beers Law," CO₂ gas absorbs certain wavelengths of infrared energy with the amount depending on the amount of CO₂ gas. A detector, outfitted with an infrared bandpass filter, only allows a certain wavelength of infrared energy that the CO₂ gas absorbs. As the CO₂ concentrations in the sampled air passes through the sample cell, the detector senses the infrared energy changes and converts them to an electrical signal. This electrical signal is then amplified and conditioned and sent to a microprocessor for processing and then sent to a display.

The CO₂ Board also uses a reference channel. The purpose of this reference channel is to "cancel" the effects of IR source changes, sample cell contamination, temperature, etc. The only difference from the CO₂ channel is that the detector is outfitted with an optical filter that is tuned to a band in the infrared spectrum that is transparent to CO₂ and other gases typically found in the medical industry. The signal from the reference channel is processed similarly to that of the CO₂ measurement channel.

The CO₂ and reference detectors work by an effect known as "pyroelectric." Pyroelectric effect works by changing energy levels, either increasing or decreasing, that are imposed on a sensing element. The detector is outfitted with an optical bandpass filter that passes only a narrow band of a determined wavelength of infrared energy. The infrared source is modulated at 15 hertz (Hz) to provide varying energy for the detector and amplifier circuits.

Correction for temperature and pressure effects on the CO₂ sample is implemented to maintain accuracy over a wide temperature and atmospheric pressure range.

Block Diagram The following block diagram aids in tracing the connections for the CO₂ module.

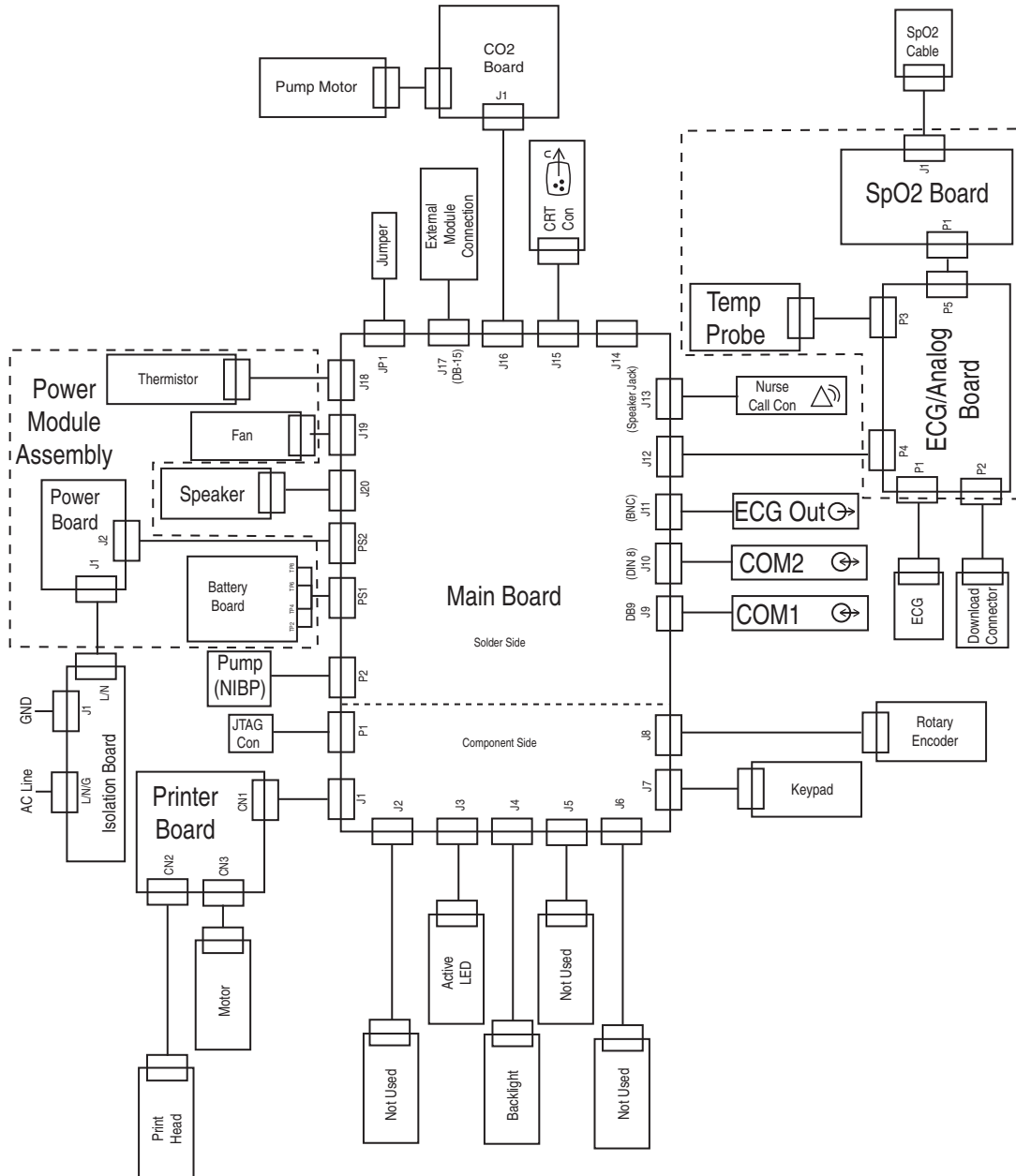

Preventative Maintenance

Maintenance Schedule Perform these maintenance tasks in addition to those listed in the Maintenance Schedule in Section 5.

EVERY PATIENT

- Change the gas sampling device and sampling line.

EVERY WEEK

- Change the water trap (or as needed).

EVERY 3 MONTHS

- Clean the exterior of the unit (or as needed).

EVERY YEAR

- Verify the CO₂ auto-calibration. Calibrate if necessary.
- Check the CO₂ absorber. Change if necessary.
- Check the gas flow rate. Adjust if necessary.

CO₂ Absorber Verification The granules in the CO₂ absorber are normally white, indicating a good absorber. If the granules remain violet or blue, the absorber is spent and needs to be replaced.

NOTE: The absorber can change color during use, but should always return to its original white color when not in use.

Verifying the state of the CO₂ absorber requires removing the external CO₂ module from the monitor. See “Check/Replace the CO₂ Absorber” located under “Disassembly” later in this appendix for instructions on removing the external CO₂ module from the monitor.

Gas Flow/CO₂ Verification TOOLS NEEDED

- Flow Meter
- Vacuum Gauge (0-25 inches of mercury)
- WaterChek™ 2+ Water Trap (CAT 938F-NC)
- Sample Line (CAT 625N)
- Calibration Gas, 10% CO₂ with accuracy $\pm 2\%$ (CAT 622)
- Regulator (CAT 623)
- Regulator Bleed Tube (CAT 613B)

⚠ CAUTION ⚠

- Calibration kits contain compressed gas cylinders. Read and obey all precautions listed on the gas cylinder labels.
- Do not use if the calibration gas cylinder is beyond its expiration date.
- Check the accuracy of the test gas. The gas must be within the accuracy stated above to ensure proper verification.

NOTE: Make sure the monitor is not in STAND BY mode before proceeding with the following procedures.

PREPARATION

1. Insert a water trap (CAT 938F-NC) and sample line (CAT 625) on the 8100E1 monitor.
2. Turn the 8100E1 monitor on and allow to run for 30 minutes.

FLOW VERIFICATION

1. Connect a flow meter to the end of the sample line and measure the flow. The flow should be 200 ml/min $\pm 10\%$ (20.0 ml/min).
2. Disconnect the flow meter from the sample line.

OCCLUSION TEST

1. Connect a vacuum gauge to the sample line. There should be more than 12.5 inches of mercury of vacuum.
2. Verify that *CO₂: OCCLUSION* appears on the monitor and that the pump turns on.
3. Disconnect the vacuum gauge from the sample line.

EXHAUST TEST

1. Place the flow meter on the Exhaust Port and measure the flow. The flow must be greater than 250 ml/min.
2. Remove the flow meter.

CO₂ VERIFICATION

1. Check that the CO₂ measurement is displayed in PERCENT. If not set in the Parameters menu (*PARAMS*).
2. Using the regulator (CAT 623) and regulator bleed tube (CAT 613B) connect the 10% CO₂ gas canister to the sample line.
3. Turn on the 10% CO₂ gas by turning on the knob on the regulator. Allow the gas to run for 30 seconds. Verify that the CO₂ reading is $\pm 6\%$ [9.4 to 10.6]. Turn off the gas when finished and disconnect from the sample line.

NOTE: The 6% accuracy is derived from the test tolerance of 4% combined with the 2% accuracy of the gas canister.

Testing Checklist A "Verification Checklist" is at the end of this appendix. This checklist should be added to the "Functional and Safety Testing Checklist" in Section 5.

CO₂ Calibration

Tools Needed The following equipment is needed to perform this procedure:

- WaterChek™ 2+ Water Trap (CAT 938F-NC)
- Sample Line (CAT 625N)
- Calibration Gas, 10% CO₂ with accuracy ±2% (CAT 622)
- Regulator (CAT 623)
- Regulator Bleed Tube (CAT 613B)
- Breath Rate Simulator (CAT 1466)

CAUTION

- Calibration kits contain compressed gas cylinders. Read and obey all precautions listed on the gas cylinder labels.

Before You Begin Make sure the CO₂ calibration gas cylinders are not depleted or nearly depleted. The pressure meter should be above zero and you should not hear a “hissing” sound when in use.

WARNING

- Never attach intravenous tubes to gas sample connections because the gas sampling lines could inadvertently be connected to intravascular fluid systems, thus allowing air into a blood vessel.

CAUTION

- Calibration kits contain compressed gas cylinders. Read and obey all precautions listed on the gas cylinder labels.
- Do not use if the calibration gas cylinder is beyond its expiration date.
- Check the accuracy of the test gas. The gas must be within the accuracy stated above to ensure proper calibration.

NOTE: Make sure the monitor is not in STAND BY mode before proceeding with the following procedure.

Procedure **PREPARATION**

1. Insert a water trap (CAT 938F-NC) and sample line (CAT 625) on the 8100E1 monitor. Connect the other end of the sample line to PORT 2 on the Breath Rate Simulator (CAT 1466).
2. Turn the 8100E1 monitor on and allow to run for 30 minutes.
3. Using the rotary knob, highlight *PARAMS*. Press the knob to enter the Parameters menu. Verify that *CO2* is *ON*. (If the *CO₂* parameter is off, highlight *CO2* using the rotary knob and press the knob. Turn the knob until *YES* is displayed and press the knob to save selection. Press the knob once more to skip the color choice.)
4. Highlight *Unit of Measure* underneath *CO2*, and press the knob to select. Rotate the knob until *PERCENT* is highlight; press the knob to save selection.
5. Highlight *EXIT* and press the rotary knob to exit the Parameters menu.
6. Highlight *CONFIG* and press the rotary knob to enter the Configuration menu.
7. In the Configuration menu, highlight *Enter Service Mode* using the rotary knob. Press the knob to select.
8. Rotate the knob so that *YES* is highlighted. Press the knob to enter Service Mode.
9. The *Enter Service Mode* password box appears. Enter password **PIA418** and press the rotary knob. The Service Mode window will appear.

CALIBRATION

1. Highlight *Enter CO2 Service* and press the rotary knob to select. Rotate the knob to *YES* and press the knob to enter CO2 Service.
2. Using the regulator (CAT 623) and regulator bleed tube (CAT 613B), connect the 10% CO₂ gas to PORT 1 on the Breath Rate Simulator. Turn on the Breath Rate Simulator and the 10% CO₂ gas.
3. Highlight *CO2 Zero Cal* and press the knob to select.
4. Turn the rotary knob until *Request CO2 Zero Cal* is displayed. Press the knob to begin a CO2 Zero Cal. Wait for the calibration to complete (about one (1) minute).

If the EXP CO₂ reading is between 10.0 and 10.1% power cycle the monitor and perform the CO₂ Verification earlier in this appendix. If the EXP CO₂ reading is above or below this range proceed with the remaining steps.

5. Select *CO2 Zero Cal* with the rotary knob, turn the knob until *Abort CO2 Zero Cal* is displayed, and press the knob to abort the CO₂ Zero Cal.
6. Using the rotary knob, highlight *CO2 Gain Adjustment* and press to select. Turn the rotary knob clockwise to increase the CO₂ reading and counter-clockwise to decrease the it until the CO₂ reading is as close to 10.0% as possible.
7. Go back to **Step 4** and repeat until the EXP CO₂ reading is between 10.0 and 10.1% at the end of the CO₂ Zero Cal.
8. When the EXP CO₂ reading is between 10.0 and 10.1%, power cycle the monitor and perform the CO₂ Verification earlier in this appendix.

Disassembly

NOTE: The “CO₂ Calibration” and “Gas Flow/CO₂ Verification” in this appendix are required after replacing the CO₂ absorber or external or internal modules.

NOTE: Perform appropriate safety tests listed on the “Field Service Test Matrix” in Section.

NOTE: Before any disassembly of the monitor, the battery must be disconnected. Follow the procedure below:

Disconnect the Battery

1. Follow all ESD procedures as stated in “Electrostatic Discharge” in “Section 7 – Disassembly.
2. Remove the two screws (PHMS 4-40 x .500 SEMS; pn 40995B003) from the battery door.
3. Remove the battery door (pn 45182B001) from the rear monitor enclosure (pn 45179B001).
4. Disconnect the cables from the battery.
5. Reassemble in reverse order.

**Check/Replace the
CO₂ Absorber**

1. Follow all ESD procedures as stated in “Electrostatic Discharge” in “Section 7 – Disassembly.”
2. Remove the two (2) screws (PHMS 6-32 x .375 SEMS; pn 40496B001) from the external CO₂ module (pn 92811A002).
3. Carefully pull the external CO₂ module away from the monitor.
4. Once the external module is disconnected from the monitor, check the condition of the CO₂ absorber (pn 40570B004).
5. If the absorber is in good condition, reassemble in reverse order and perform the “Gas Flow/CO₂ Verification” in this appendix.

If the absorber must be replaced, continue with this procedure.

6. Disconnect the absorber.

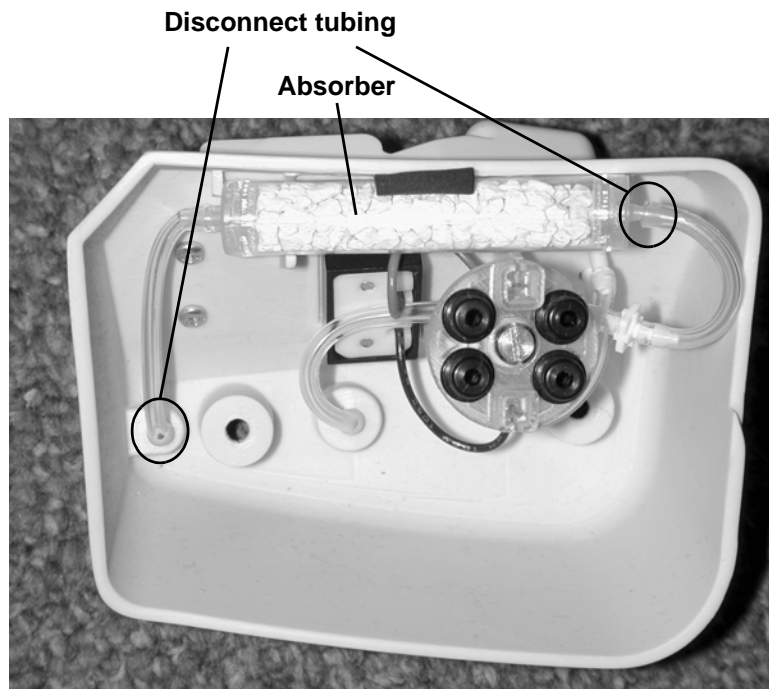

Figure A-3: Disconnect CO₂ Absorber

7. Replace CO₂ absorber.
8. Reassemble in reverse order.

Replace the External
CO₂ Absorber

1. Follow all ESD procedures as stated in “Electrostatic Discharge” in “Section 7 – Disassembly.”
2. Remove the two (2) screws (PHMS 6-32 x .375 SEMS; pn 40496B001) from the external CO₂ module (pn 92811A002).
3. Carefully pull the external CO₂ module away from the monitor.
4. Replace external CO₂ module.
5. Reassemble in reverse order.

Replace the Internal
CO₂ Module

1. Follow all ESD procedures as stated in “Electrostatic Discharge” in “Section 7 – Disassembly.”
2. Remove the printer module (pn 92804A001) or printer cover (pn 45183B001) from the rear enclosure.
 - a. Remove the two (2) screws (PHMS 4-40 x .312 SEMS; pn 40995B001) holding the module or cover to the rear enclosure.
 - b. If the monitor has a printer module, label and remove the ribbon cable from the printer module.
3. Remove the external CO₂ module (pn 92811A002) following the instructions above.
4. Remove the rear enclosure (pn 92810C001).
 - a. Remove the four (4) nylon screws (PHMS 8-32 x .375 NYLON; pn 42654B002) on the bottom of the enclosure.

NOTE: The plastic insulator bottom (pn 45194B001) will come off when the screws are removed. Do not lose.
 - b. Remove the two (2) screws (FHMS 8-32 x .375 PH PL; pn 40083B002) located under the insulator.
 - c. Remove the two (2) screws (PHMS 4-40 x .500 SEMS; pn 40995B003) from the back of the battery door.
 - d. Remove the two (2) screws (FHMS 6-32 x .375; pn 40180B002) from the power area.
 - e. Remove the six (6) screws (PHMS 6-32 x .375 SEMS; pn 40496B001) holding the rear enclosure to the front enclosure.
5. Disconnect the ribbon cable at **J1** on the internal CO₂ module’s PCB board.
6. Remove the four (4) screws (PHMS 6-32 x .375 SEMS; pn 40496B001) holding the internal CO₂ module (pn 92811A001) to the chassis.
7. Replace the internal CO₂ module.
8. Reassemble in reverse order.

Troubleshooting**SYMPTOM: TRAP ERROR OR CO₂ MALFUNCTION**

Problem	Solution
<ul style="list-style-type: none">• Trap is plugged or leaks• Tubes to the trap manifold are loose or pinched• Bad valve or pump	Replace Trap Check manifold connections Contact CSI Service Department

Verification Checklist

Functional and Safety Testing Checklist – CO₂

This checklist may be copied as needed to record field testing. Add this page to the “Functional and Safety Testing Checklist” in Section 5 of this manual.

Monitor Serial Number _____
CO2 Processor Software Rev. _____

Gas Flow Verification

	Pass	Fail
Flow Calibration	_____	_____
Occlusion	_____	_____
Exhaust Test	_____	_____
CO ₂ Test	_____	_____

Certification of CO₂ Verification

Technician: _____
Date: _____

REVISIONS			
REV.	DATE	DESCRIPTION	BY
1	5/12/06	SEE ECN #8842	DBL
2	06-14-2006	SEE ECN #8891	LBS
3	5/1/08	SEE ECN #10136	DBL
4	8/20/09	SEE ECN #10416	DBL

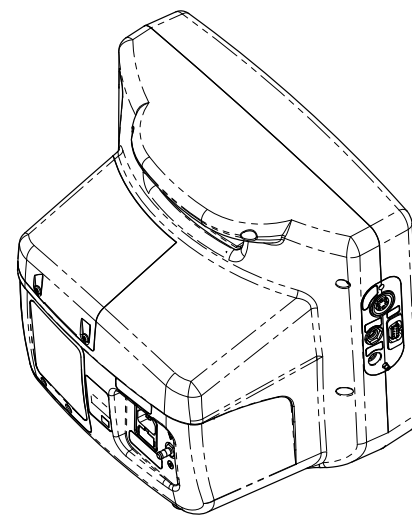
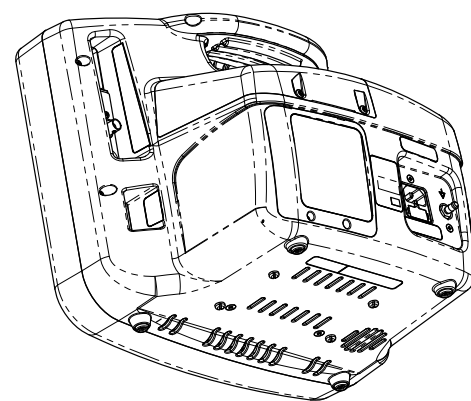
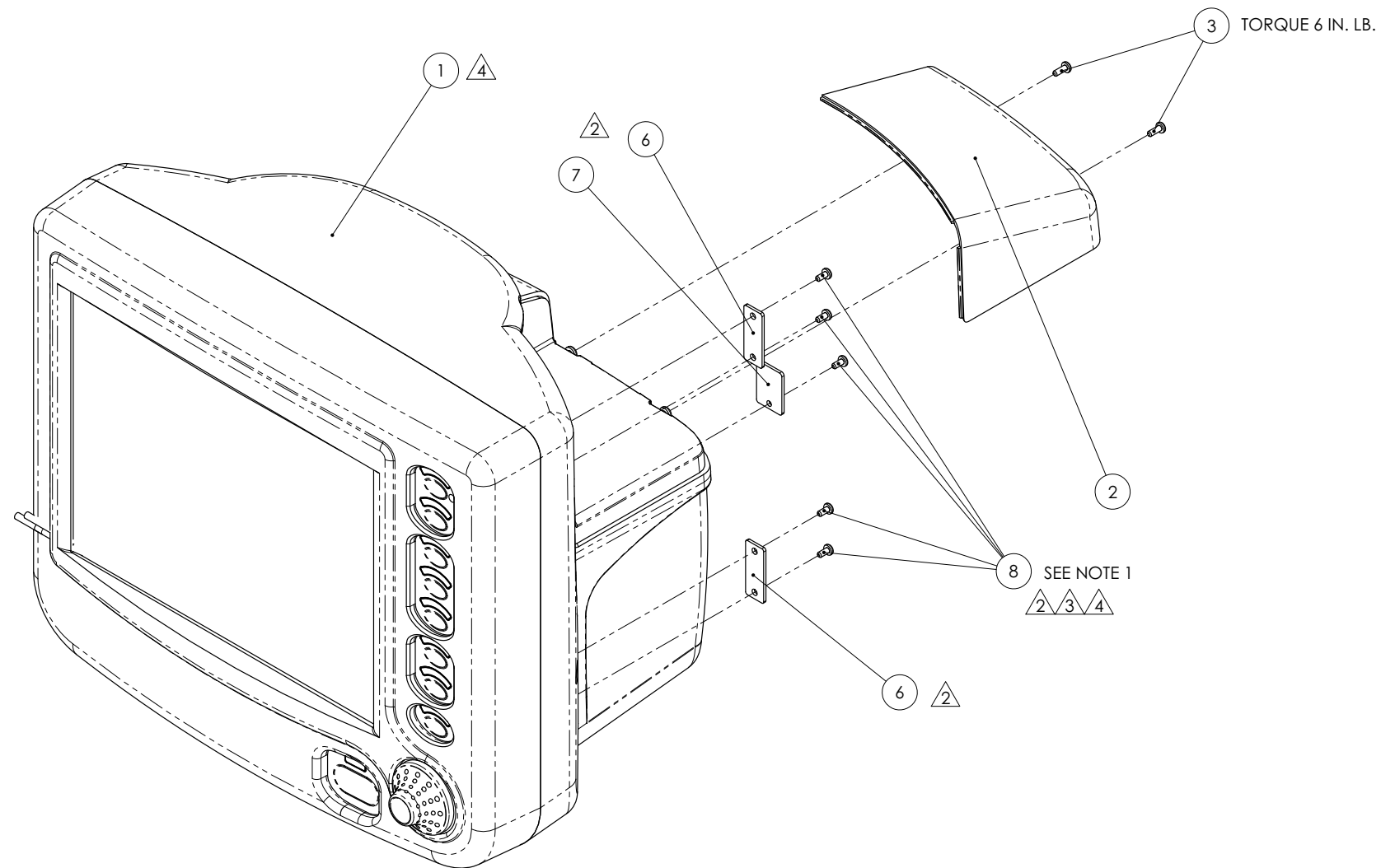

NOTES:

- △ 1. TIGHTEN SCREWS (ITEM 8) FLUSH AND DO NOT OVER TIGHTEN.
- △ 2. USE 93979PXXX ASSEMBLY PROCEDURE.
- △ 3. SEE 8100EX DRAWING FOR LABEL PLACEMENT OF 95773AXXX LABELS.

SW



DRAWN BY: L. SOROKA	CHECK BY:	ENG. APPR.: L. SOROKA 3/7/06
DATE: 01-06-2006	RELEASE DATE:	Q.A. APPR.: A. KAPLAN 3/8/06
SCALE: 1:2	DO NOT SCALE PRINT	MFG. APPR.: J. SZOLYGA 1/9/06

TOLERANCE UNLESS OTHERWISE SPECIFIED:
 XX: +/- .020
 XXX: +/- .005
 ANGLES: +/- 1 DEGREE

CONFIDENTIAL: THIS DOCUMENT CONTAINS CONFIDENTIAL INFORMATION AND MAY NOT BE COPIED OR DIVULGED WITHOUT WRITTEN CONSENT OF CRITICARE SYSTEMS, INC.

TITLE: FINAL ASSEMBLY 8100E	PART NO.: 93979A001	REV.: 4
DIST: 302	SHEET 1 OF 1	

REVISIONS			
REV.	DATE	DESCRIPTION	BY
1	5/12/04	SEE ECN #8842	DBL
2	06-14-2006	SEE ECN #8891	LBS
3	5/1/08	SEE ECN #10136	DBL
4	8/20/09	SEE ECN #10416	DBL

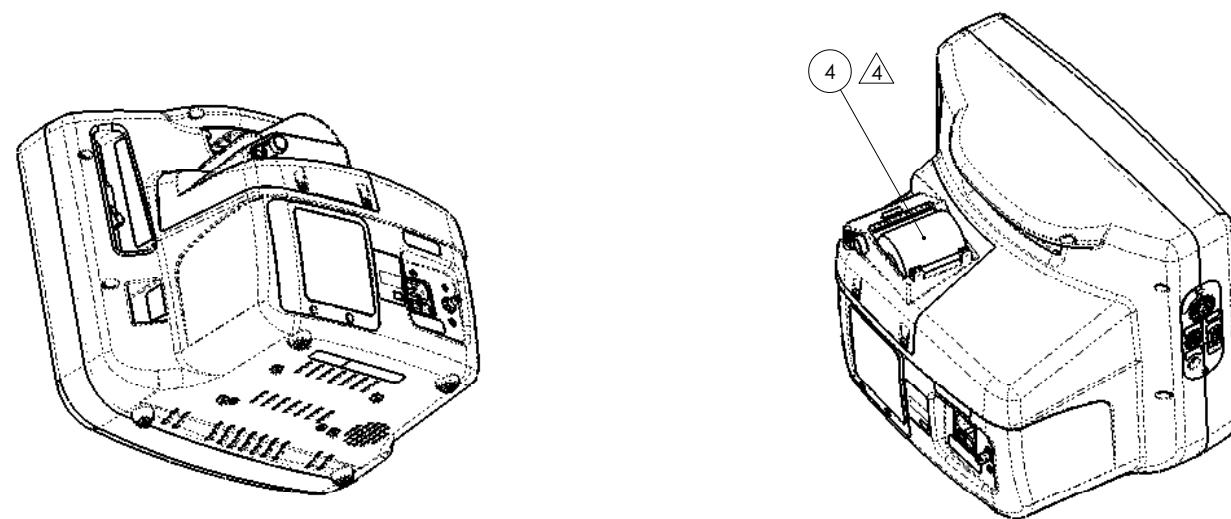
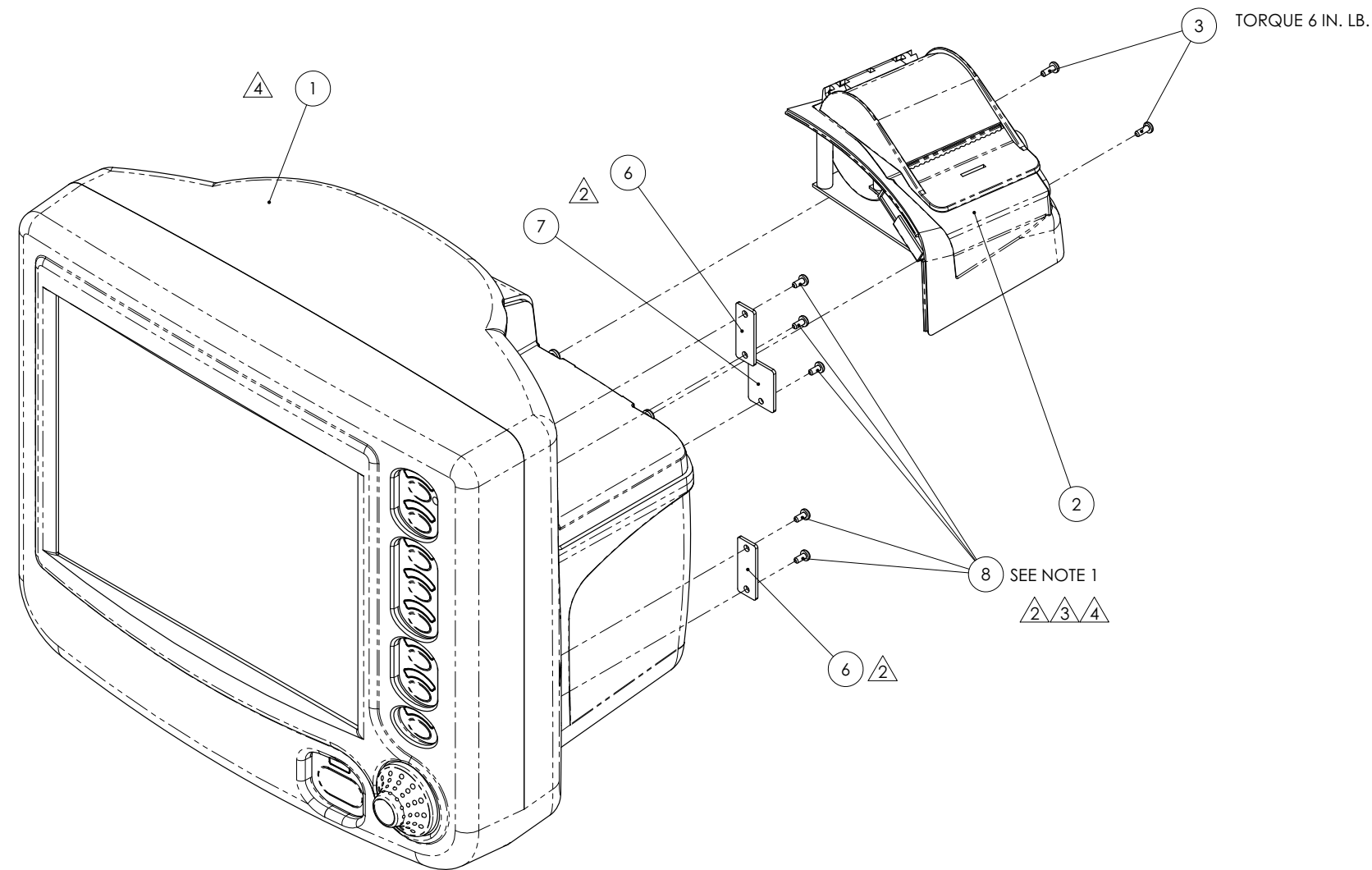

NOTES:

- △ 1. TIGHTEN SCREWS (ITEM 8) FLUSH AND DO NOT OVER TIGHTEN.
- △ 2. USE 93979PXXX ASSEMBLY PROCEDURE.
- △ 3. ADD PAPER (ITEM 4) TO PRINTER.
- △ 4. SEE 8100EX DRAWING FOR LABEL PLACEMENT OF 95773AXXX LABELS.

SW



DRAWN BY: L. SOROKA	CHECK BY:	ENG. APPR.: L. SOROKA 3/7/06
DATE: 01-06-2006	RELEASE DATE:	Q.A. APPR.: A. KAPLAN 3/8/06
SCALE: 1:2	DO NOT SCALE PRINT	MFG. APPR.: J. SZOLYGA 1/9/06
TOLERANCE UNLESS OTHERWISE SPECIFIED: XX: +/- .020 XXX: +/- .005 ANGLES: +/- 1 DEGREE	CONFIDENTIAL: THIS DOCUMENT CONTAINS CONFIDENTIAL INFORMATION AND MAY NOT BE COPIED OR DIVULGED WITHOUT WRITTEN CONSENT OF CRITICARE SYSTEMS, INC.	
TITLE: FINAL ASSEMBLY 8100EP	PART NO.: 93979A002	REV.: 4
DIST: 302	SHEET 1 OF 1	

REVISIONS			
REV.	DATE	DESCRIPTION	BY
1	04/17/07	SEE ECN #9166	SC
2	12/19/07	SEE ECN #10053	RWK
3	5/1/08	SEE ECN #10136	DBL
4	8/20/09	SEE ECN #10416	DBL

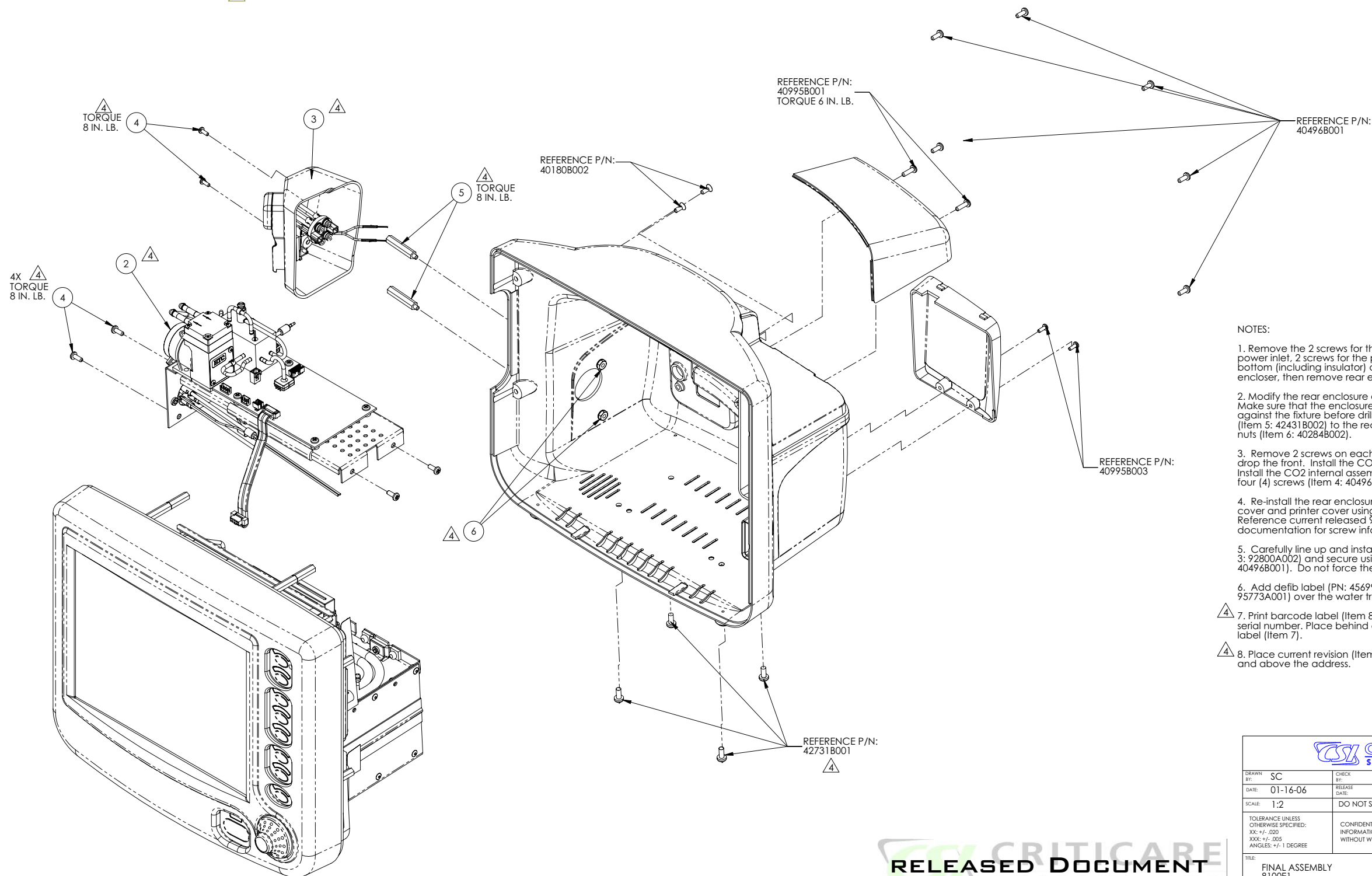
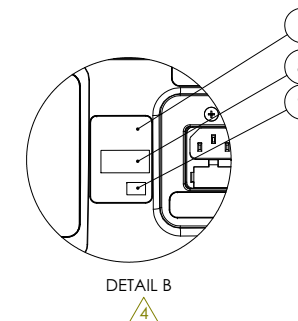
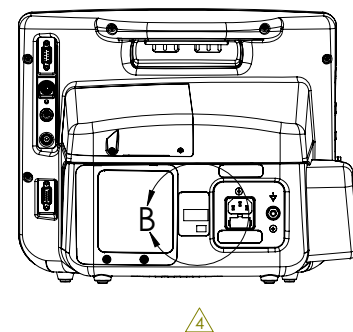
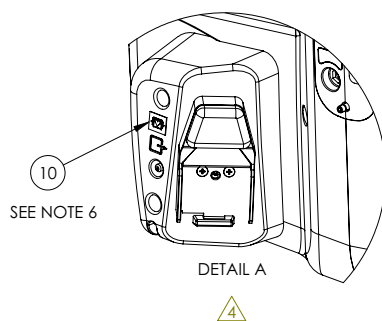
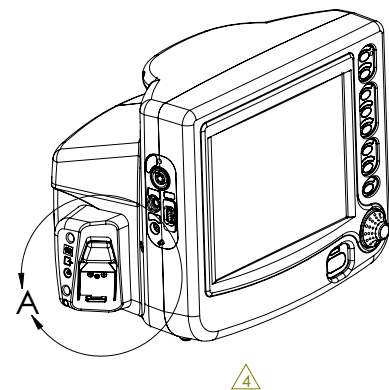
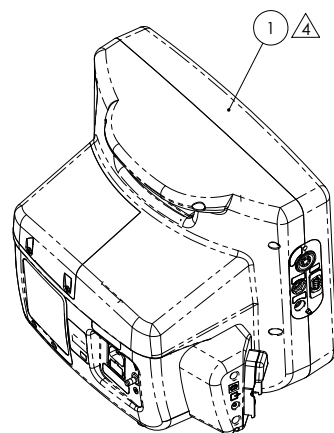

NOTES:

1. Remove the 2 screws for the Battery Door, 2 screws near the power inlet, 2 screws for the printer cover, 6 six screws on the bottom (including insulator) and 8 screws securing the rear enclosure, then remove rear enclosure.
2. Modify the rear enclosure as shown using drill fixture T3314. Make sure that the enclosure is pressed firmly and completely against the fixture before drilling. Secure two (2) standoffs (Item 5: 42431B002) to the rear enclosure using two (2) KEPS nuts (Item 6: 40284B002).
3. Remove 2 screws on each side of the chassis assembly to drop the front. Install the CO2 cable into J16 of the Main PCB. Install the CO2 internal assembly (Item 2) and secure it using four (4) screws (Item 4: 40496B001).
4. Re-install the rear enclosure (including insulator), battery cover and printer cover using previously removed hardware. Reference current released 92800A001 and 93979A001/002 documentation for screw information.
5. Carefully line up and install the external CO2 Module (Item 3: 92800A002) and secure using two (2) screws (Item 4: 40496B001). Do not force the connection.
6. Add defib label (PN: 45699B001, part of label set PN: 95773A001) over the water trap manifold as shown.
7. Print barcode label (Item 8) containing CAT, part, and serial number. Place behind clear window on serial number label (Item 7).
8. Place current revision (Item 9) onto the serial tag (Item 7) and above the address.

SW

RELEASED DOCUMENT
CRITICARE SYSTEMS, INC.

CRITICARE SYSTEMS, INC.	
DRAWN BY: SC	CHECK BY: ENG. APPR: S. COOGAN 03/05/07
DATE: 01-16-06	RELEASE DATE: Q.A. APPR: A. KAPLAN 03/05/07
SCALE: 1:2	DO NOT SCALE PRINT MFG. APPR: K. HAWVER 03/05/07
TOLERANCE UNLESS OTHERWISE SPECIFIED: XXX - +/- .020 XXX - +/- .015 ANGLES - +/- 1 DEGREE	
CONFIDENTIAL: THIS DOCUMENT CONTAINS CONFIDENTIAL INFORMATION AND MAY NOT BE COPIED OR DIVULGED WITHOUT WRITTEN CONSENT OF CRITICARE SYSTEMS, INC.	
TITLE: FINAL ASSEMBLY 8100E1	PART NO.: 93979A011
REV: 4	REV: 4
DWG: 302	SHEET 1 OF 1

REVISIONS			
REV.	DATE	DESCRIPTION	BY
1	04/17/07	SEE ECN #9166	SC
2	12/19/07	SEE ECN #10053	RWK
3	5/1/08	SEE ECN #10136	DBL
4	8/21/09	SEE ECN #10416	DBL

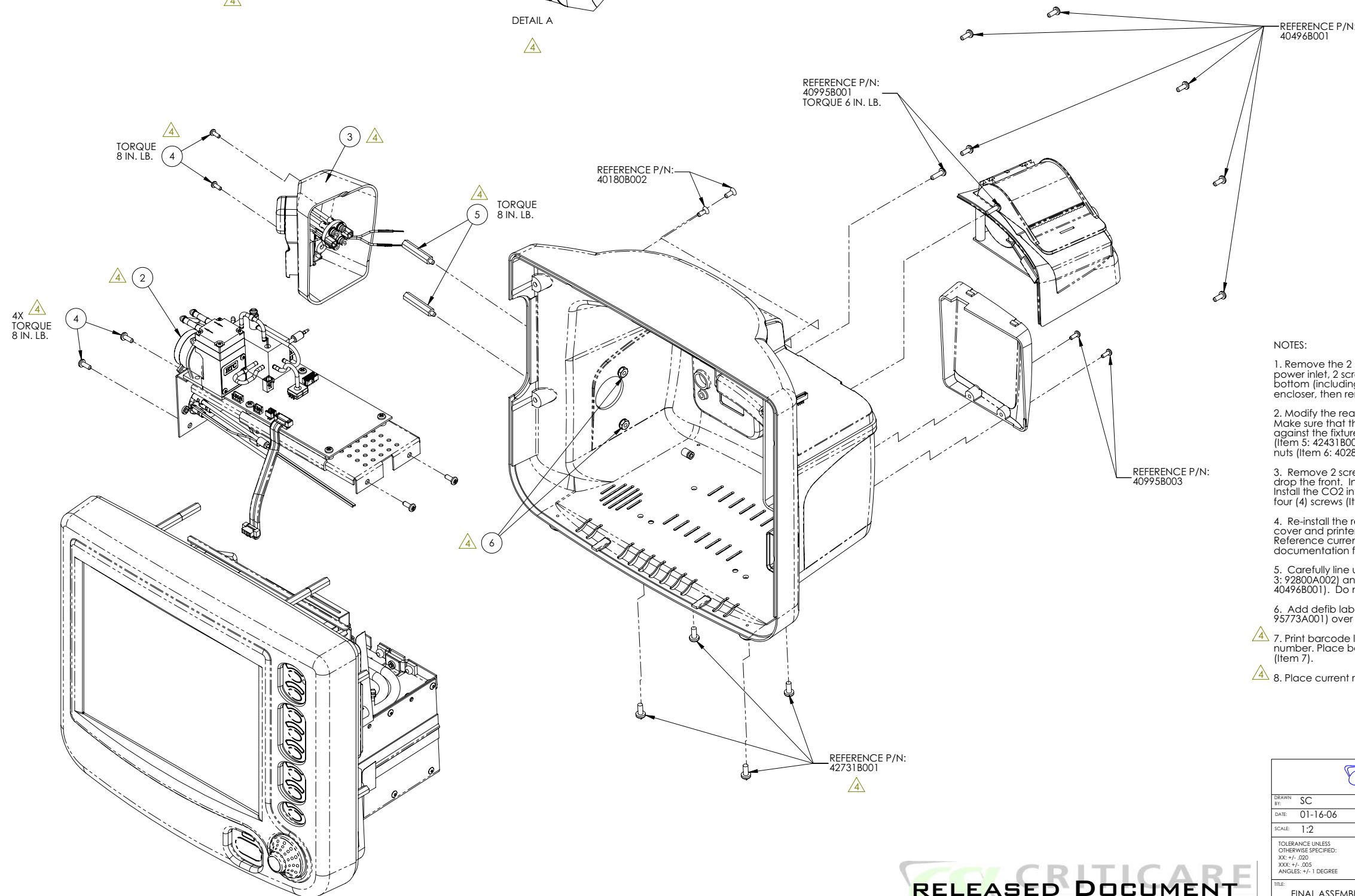
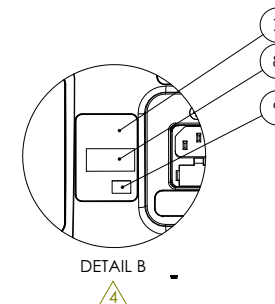
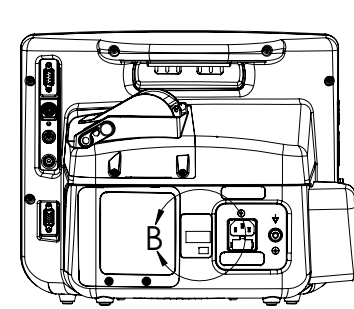
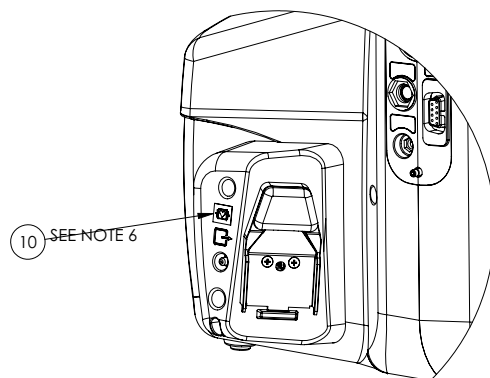
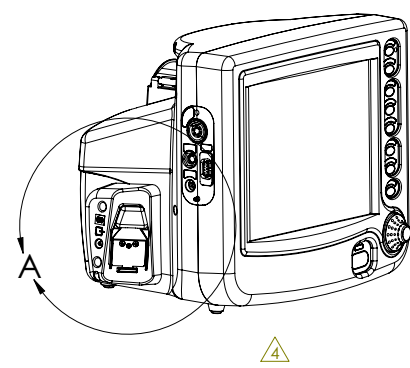
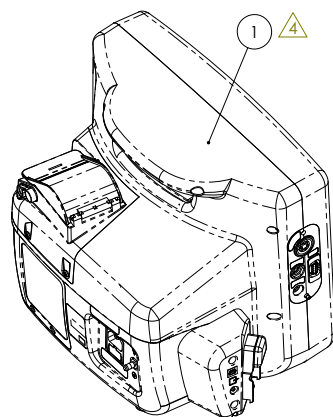

REFERENCE P/N:
40496B001

REFERENCE P/N:
40995B001
TORQUE 6 IN. LB.

REFERENCE P/N:
40180B002

REFERENCE P/N:
40995B003

REFERENCE P/N:
42731B001

- NOTES:
- Remove the 2 screws for the Battery Door, 2 screws near the power inlet, 2 screws for the printer cover, 6 six screws on the bottom (including insulator) and 8 screws securing the rear enclosure, then remove rear enclosure.
 - Modify the rear enclosure as shown using drill fixture T3314. Make sure that the enclosure is pressed firmly and completely against the fixture before drilling. Secure two (2) standoffs (Item 5: 42431B002) to the rear enclosure using two (2) KEPS nuts (Item 6: 40284B002).
 - Remove 2 screws on each side of the chassis assembly to drop the front. Install the CO2 internal assembly (Item 2) and secure it using four (4) screws (Item 4: 40496B001).
 - Re-install the rear enclosure (including insulator), battery cover and printer cover using previously removed hardware. Reference current released 92800A001 and 93979A001/002 documentation for screw information.
 - Carefully line up and install the external CO2 Module (Item 3: 92800A002) and secure using two (2) screws (Item 4: 40496B001). Do not force the connection.
 - Add defib label (PN: 45699B001, part of label set PN: 95773A001) over the water trap manifold as shown.
 - Print barcode label (Item 8) containing CAT, part and serial number. Place behind clear window on serial number label (Item 7).
 - Place current revision (Item 9) onto the serial tag (Item 7).

SW

RELEASED DOCUMENT
CRITICARE SYSTEMS, INC.

CRITICARE SYSTEMS, INC.			
DRAWN BY: SC	CHECK BY:	ENG. APPR.: S. COOGAN	03/05/07
DATE: 01-16-06	RELEASE DATE:	Q.A. APPR.: A. KAPLAN	03/05/07
SCALE: 1:2	DO NOT SCALE PRINT	MFG. APPR.: K. HAWVER	03/05/07
TOLERANCE UNLESS OTHERWISE SPECIFIED: XX +/- .020 XXX +/- .015 ANGLES +/- 1 DEGREE		CONFIDENTIAL: THIS DOCUMENT CONTAINS CONFIDENTIAL INFORMATION AND MAY NOT BE COPIED OR DIVULGED WITHOUT WRITTEN CONSENT OF CRITICARE SYSTEMS, INC.	
TITLE: FINAL ASSEMBLY 8100E1	PART NO.: 93979A012	REV: 4	
DD: 302	SHEET 1 OF 1		

REVISIONS			
REV.	DATE	DESCRIPTION	BY
1	5/15/06	SEE ECH #8842	DBL
2	06-14-2006	SEE ECH #8891	LBS
3	11-29-2006	SEE ECH #926	LBS
4	01-26-07	SEE ECH #9079	SC
5	5/1/08	SEE ECH #10136	DBL
6	4/3/09	SEE ECH #10407	DBL
7	7/20/09	SEE ECH #10416	DBL

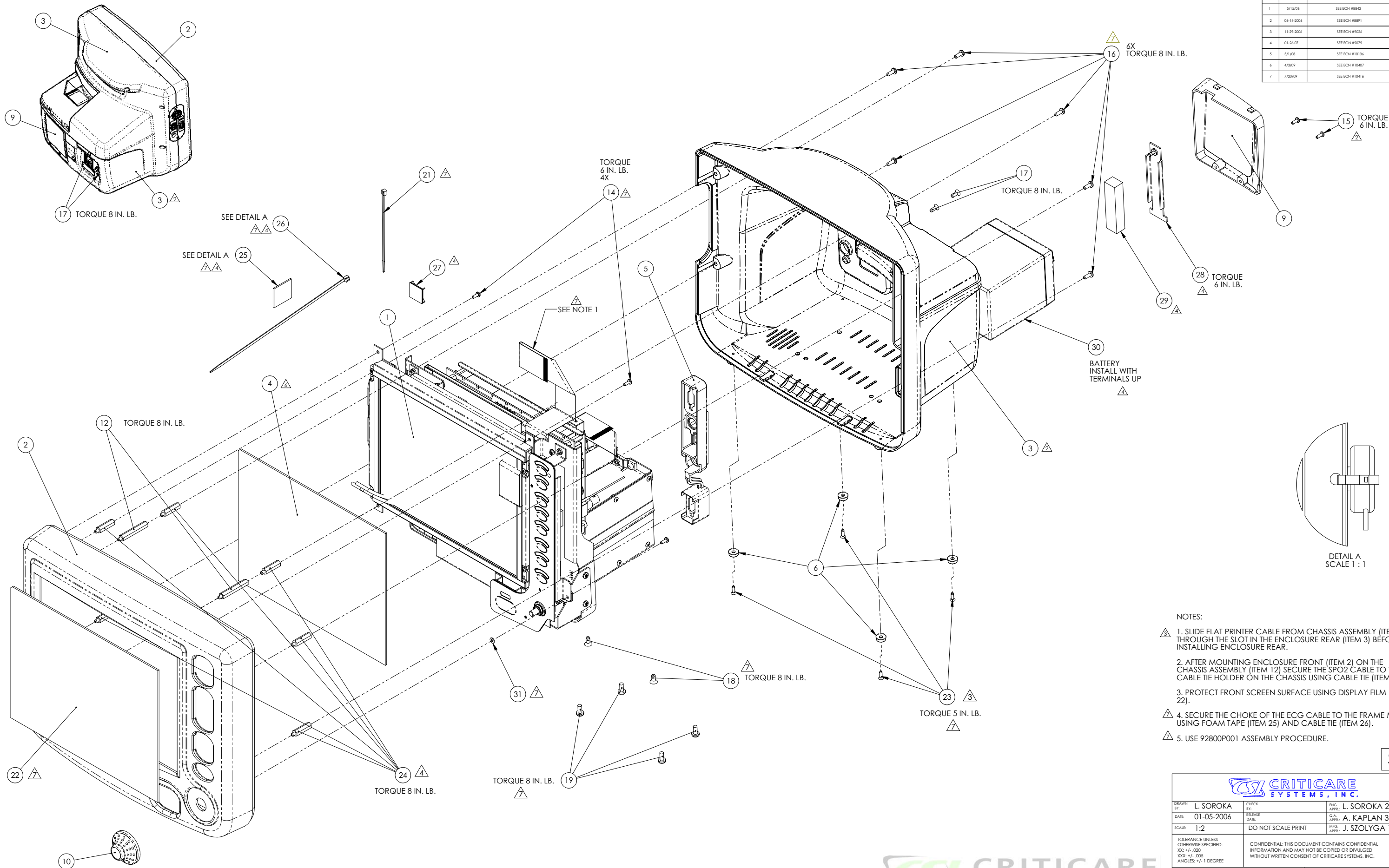

- NOTES:
- ⚠ 1. SLIDE FLAT PRINTER CABLE FROM CHASSIS ASSEMBLY (ITEM 1) THROUGH THE SLOT IN THE ENCLOSURE REAR (ITEM 3) BEFORE INSTALLING ENCLOSURE REAR.
 - 2. AFTER MOUNTING ENCLOSURE FRONT (ITEM 2) ON THE CHASSIS ASSEMBLY (ITEM 1) SECURE THE SPO2 CABLE TO THE CABLE TIE HOLDER ON THE CHASSIS USING CABLE TIE (ITEM 21).
 - 3. PROTECT FRONT SCREEN SURFACE USING DISPLAY FILM (ITEM 22).
 - ⚠ 4. SECURE THE CHOKE OF THE ECG CABLE TO THE FRAME MAIN USING FOAM TAPE (ITEM 25) AND CABLE TIE (ITEM 26).
 - ⚠ 5. USE 92800P001 ASSEMBLY PROCEDURE.

SW

CRITICARE SYSTEMS, INC.	
DRAWN BY: L. SOROKA	CHECK BY: L. SOROKA 2/16/06
DATE: 01-05-2006	RELEASE DATE: A. KAPLAN 3/8/06
SCALE: 1:2	DO NOT SCALE PRINT
MFG. APPR.: J. SZOLYGA 1/9/06	
TOLERANCE UNLESS OTHERWISE SPECIFIED: XXX+/- .020 XXX+/- .015 ANGLES +/- 1 DEGREE	
CONFIDENTIAL: THIS DOCUMENT CONTAINS CONFIDENTIAL INFORMATION AND MAY NOT BE COPIED OR DIVULGED WITHOUT WRITTEN CONSENT OF CRITICARE SYSTEMS, INC.	
TITLE: ASSEMBLY MAIN MONITOR 8100E/EP	PART NO.: 92800A001
REV: 7	SHEET 1 OF 1

CRITICARE SYSTEMS, INC.
RELEASED DOCUMENT

REVISIONS			
REV.	DATE	DESCRIPTION	BY
1	5/15/06	SEE ECH #8842	DBL
2	06-14-2006	SEE ECH #8891	LBS
3	11-29-2006	SEE ECH #9026	LBS
4	8/18/07	SEE ECH #10416	DBL

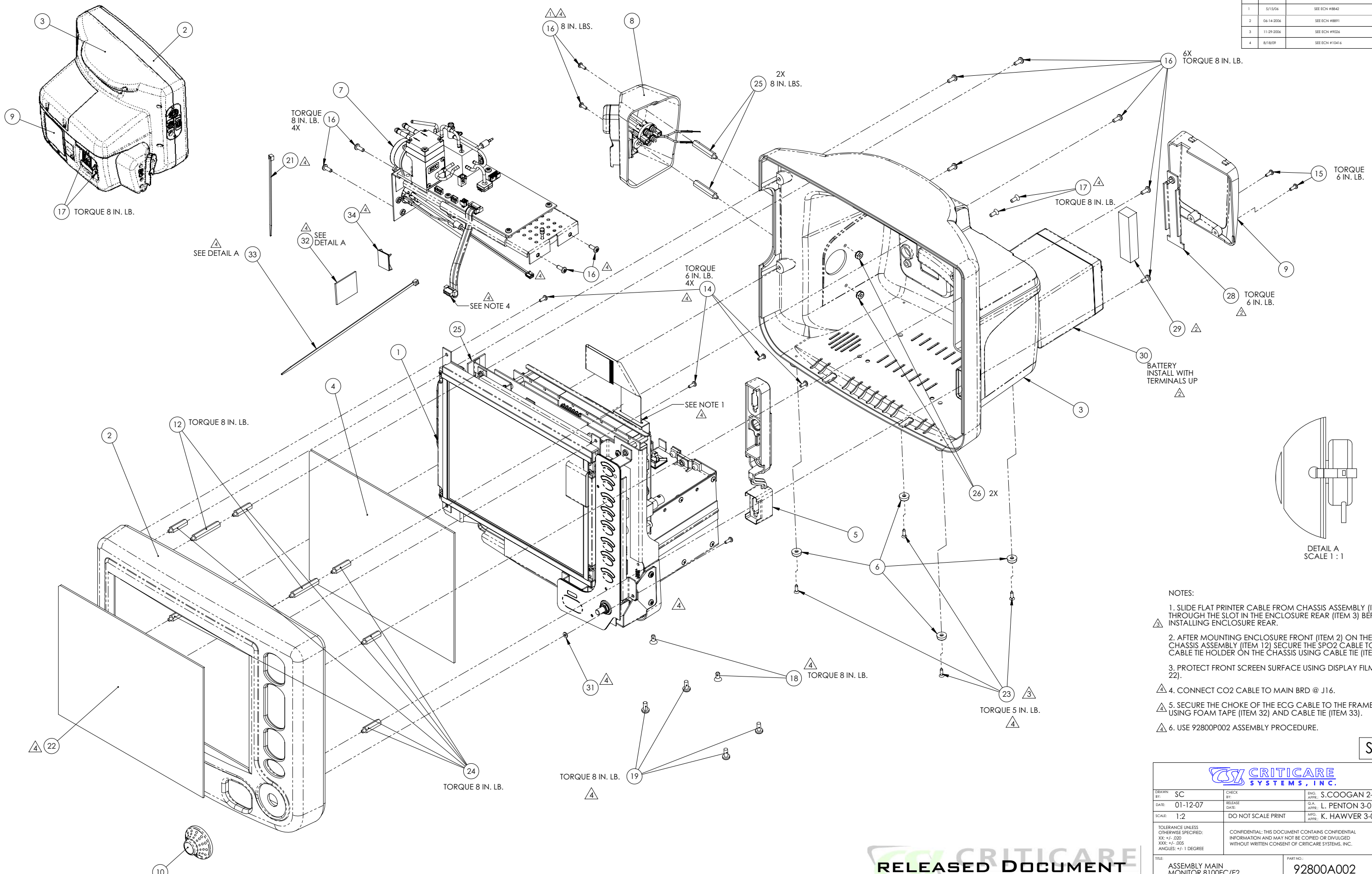

- NOTES:
1. SLIDE FLAT PRINTER CABLE FROM CHASSIS ASSEMBLY (ITEM 1) THROUGH THE SLOT IN THE ENCLOSURE REAR (ITEM 3) BEFORE INSTALLING ENCLOSURE REAR.
 2. AFTER MOUNTING ENCLOSURE FRONT (ITEM 2) ON THE CHASSIS ASSEMBLY (ITEM 12) SECURE THE SPO2 CABLE TO THE CABLE TIE HOLDER ON THE CHASSIS USING CABLE TIE (ITEM 21).
 3. PROTECT FRONT SCREEN SURFACE USING DISPLAY FILM (ITEM 22).
 4. CONNECT CO2 CABLE TO MAIN BRD @ J16.
 5. SECURE THE CHOKE OF THE ECG CABLE TO THE FRAME MAIN USING FOAM TAPE (ITEM 32) AND CABLE TIE (ITEM 33).
 6. USE 92800P002 ASSEMBLY PROCEDURE.

SW



DRAWN BY: SC	CHECK BY: S.COOGAN 2-28-07	ENG. APPR.:
DATE: 01-12-07	RELEASE DATE: L. PENTON 3-01-07	G.A. APPR.:
SCALE: 1:2	DO NOT SCALE PRINT	SIGN. APPR. K. HAWVER 3-01-07
TOLERANCE UNLESS OTHERWISE SPECIFIED: XX: +/- .020 XXX: +/- .005 ANGLES: +/- 1 DEGREE		
CONFIDENTIAL: THIS DOCUMENT CONTAINS CONFIDENTIAL INFORMATION AND MAY NOT BE COPIED OR DIVULGED WITHOUT WRITTEN CONSENT OF CRITICARE SYSTEMS, INC.		
TITLE: ASSEMBLY MAIN MONITOR 8100EC/E2	PART NO.: 92800A002	REV.: 4
DIST: -		SHEET 1 OF 1

RELEASED DOCUMENT
CRITICARE SYSTEMS, INC.

REVISIONS			
REV.	DATE	DESCRIPTION	BY
1	5/15/06	SEE ECN #8842	DBL
2	6/12/06	SEE ECN #8885	LBS
3	1/22/07	SEE ECN #9079	SC
4	4/30/08	SEE ECN #10136	DBL
5	6/23/09	SEE ECN #10416	DBL

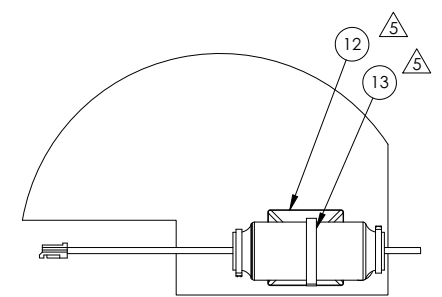
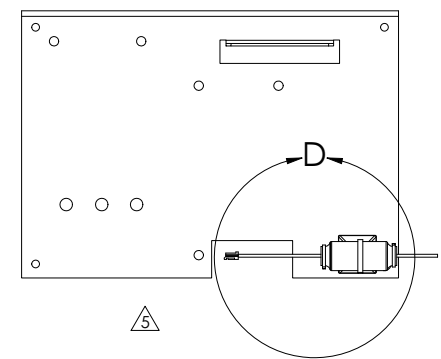
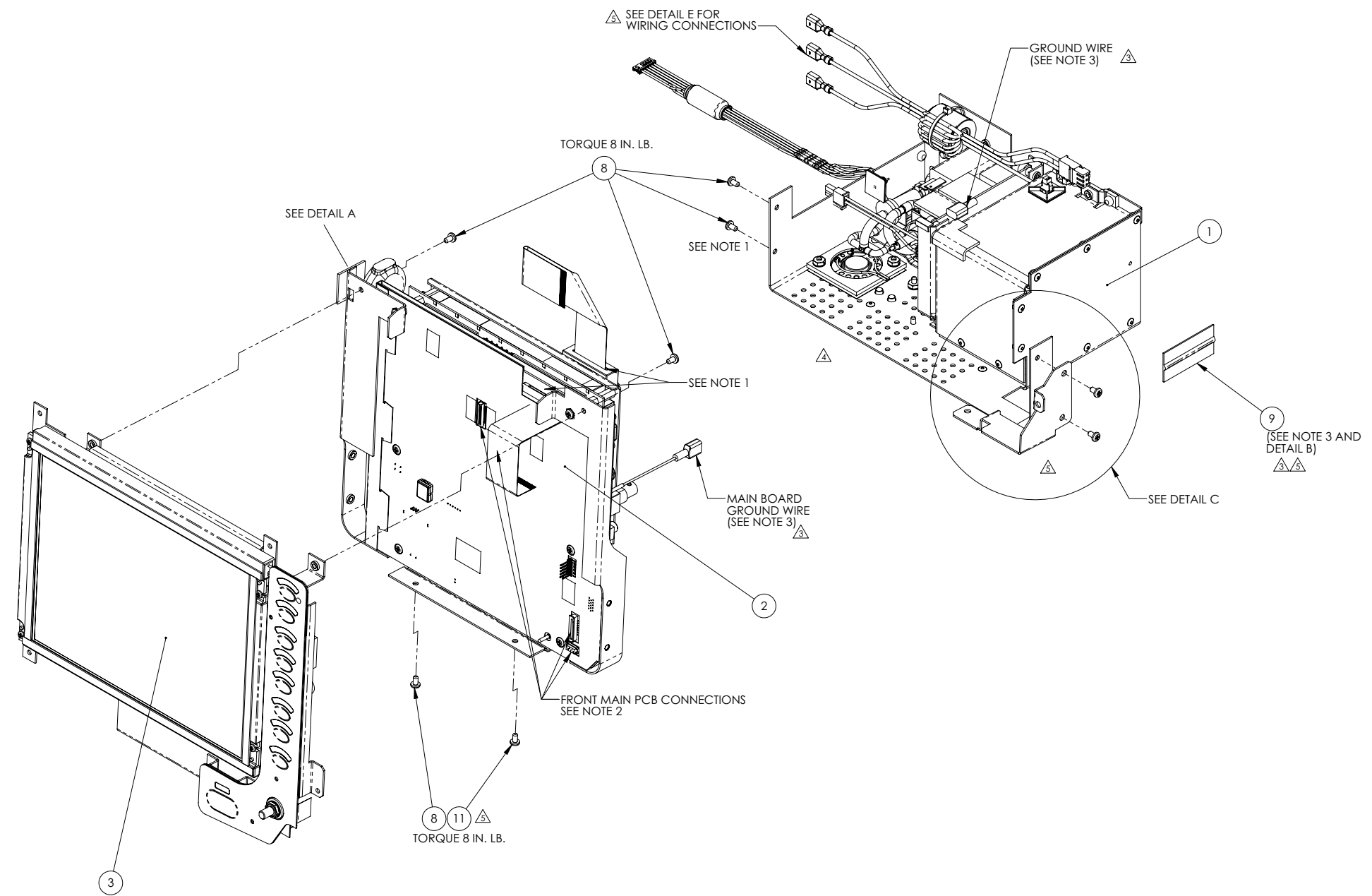

DETAIL D
SCALE 1 : 1

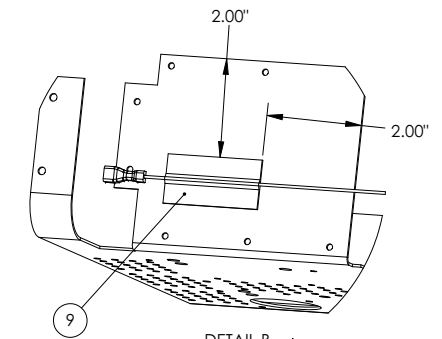

DETAIL B

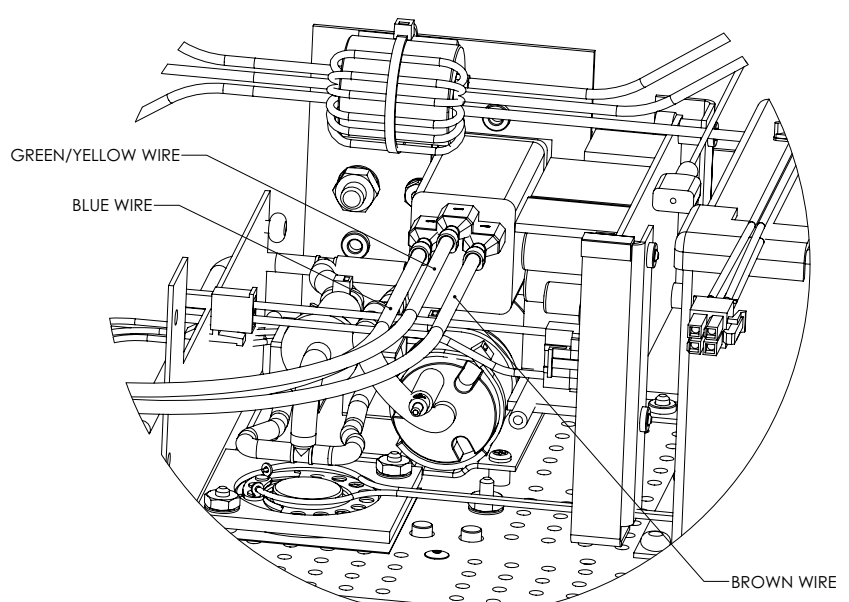

DETAIL E
SCALE 1 : 1

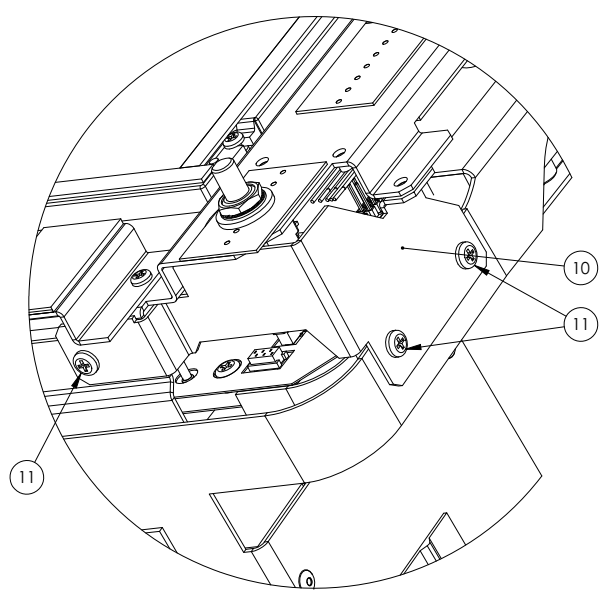

DETAIL C
SCALE 1 : 1

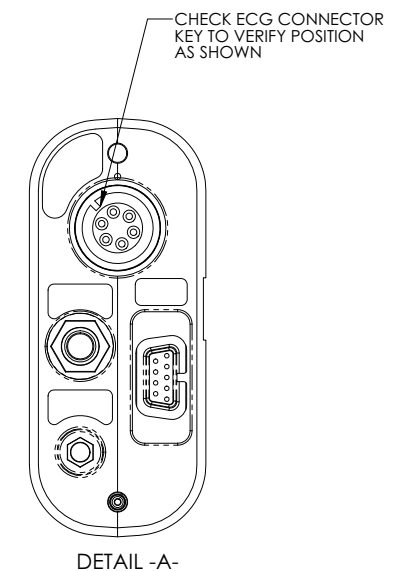

DETAIL -A-

- NOTES:
1. AFTER ATTACHING CHASSIS MAIN (ITEM 2) TO THE CHASSIS BOTTOM (ITEM 1) USING BOTTOM SCREWS (ITEM 8) PLUG IN ALL ELECTRICAL CONNECTIONS TO THE MAIN PCB. LIFT CHASSIS MAIN AND INSTALL TOP SCREWS.
 2. BEFORE ATTACHING CHASSIS DISPLAY (ITEM 3) CONNECT ALL CABLES TO THE MAIN PCB.
 3. CUT 2 INCHES OF FOAM TAPE (ITEM 9) AND APPLY TO THE WHITE WIRE. REMOVE THE PAPER FORM THE TAPE AND SECURE THE GROUND WIRE APPROXIMATELY 2 INCHES DOWN FROM THE TOP OF THE BATTERY COMPARTMENT AND APPROXIMATELY 2 INCHES FROM RIGHT SIDE. SEE DETAIL B. CONNECT THE GROUND TO THE MAIN BOARD GROUND WIRE CONNECTOR.
 4. USE 92803P001.

VENDOR SHOULD COMPLY WITH THE FOLLOWING CSI QUALITY REQUIREMENTS: Q1, Q2, Q4, Q5, Q6, Q7, Q10, Q11 AND Q16. IN ADDITION THE QUALITY REQUIREMENTS Q9, Q13 AND Q17 APPLY. SEE CSI WEB SITE (www.csiusa.com/pdf/QA_Requirements.pdf) FOR THE DEFINITION OF THE QUALITY REQUIREMENTS.

SW

		ENG. APPR.: L. SOROKA 3/7/06
		RELEASE DATE: A. KAPLAN 3/8/06
DRAWN BY: L. SOROKA DATE: 1-5-2006 SCALE: 1:2	CHECK BY: DATE: DO NOT SCALE PRINT	MFG. APPR.: J. SZOLYGA 1/9/06
TOLERANCE UNLESS OTHERWISE SPECIFIED: XX: +/- .020 XXX: +/- .005 ANGLES: +/- 1 DEGREE		CONFIDENTIAL: THIS DOCUMENT CONTAINS CONFIDENTIAL INFORMATION AND MAY NOT BE COPIED OR DIVULGED WITHOUT WRITTEN CONSENT OF CRITICARE SYSTEMS, INC.
TITLE: ASSEMBLY CHASSIS MONITOR		PART NO.: 92803A001 REV.: 5

RELEASED DOCUMENT

REVISIONS			
REV.	DATE	DESCRIPTION	BY
1	03-20-06	SEE ECN #8715	LBS
2	05/15/06	SEE ECN #8842	DBL
3	06-12-06	SEE ECN #8886	LBS
4	09/13/06	SEE ECN #8941	RWK
5	01/22/07	SEE ECN #9079	SC
6	4/30/08	SEE ECN #10136	DBL
7	7/29/08	SEE ECN #10466	DBL

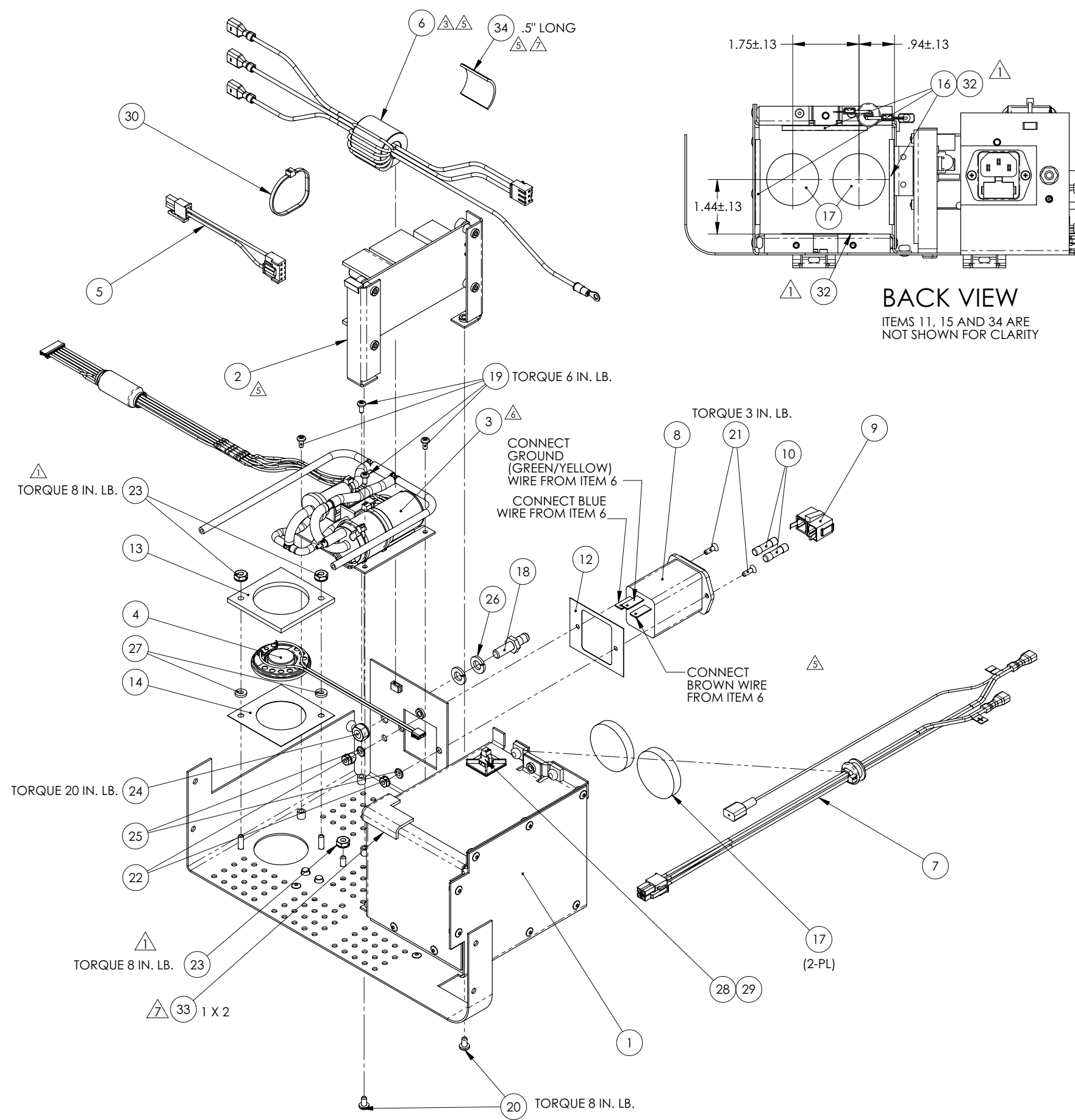

BACK VIEW
ITEMS 11, 15 AND 34 ARE NOT SHOWN FOR CLARITY

NOTES:

1. POSITION BATTERY SLIDE (ITEM 32) ON THE BOTTOM OF THE BATTERY COMPARTMENT LINED UP WITH THE FRONT EDGE OF THE BATTERY COMPARTMENT AND AT EQUAL DISTANCES FROM THE SIDE WALLS.
2. POSITION FOAM PAD BATTERY (ITEM 16) ON THE TOP AND SIDE WALLS OF THE BATTERY COMPARTMENT (CENTERED FROM SIDE TO SIDE AND FROM TOP TO BOTTOM AS SHOWN ON THE BACK VIEW) CLOSE TO THE REAR WALL. COVER EACH OF THESE PADS WITH BATTERY SLIDE (ITEM 32) AND STICK OVERLAPPING PARTS OF THE BATTERY SLIDES TO THE WALLS IN FRONT OF THE FOAM PADS.
3. TO CUSHION FERRITE OF THE CABLE (ITEM 6) FROM THE CHASSIS (ITEM 1), PUT FOAM TAPE (ITEM 34) ON THE FERRITE SIDE FACING CHASSIS.
4. VERIFY FOR NO ELECTRICAL CONTINUITY BETWEEN POWER INPUT MODULE (ITEM 8) AND CHASSIS (ITEM 1) BEFORE CONNECTING THE CABLE (ITEM 6) TO THE POWER INPUT MODULE (ITEM 8).
5. ROUTE WIRES FROM THE BATTERY CABLE (ITEM 7) OVER BATTERY BRACKET (ITEM 15). MAKE SURE WIRES ARE NOT PINCHED UNDER FOAM PAD (ITEM 33).

RELEASED DOCUMENT **CRITICARE SYSTEMS, INC.** SW

CRITICARE SYSTEMS, INC.		
DRAWN BY: L. SOROKA	CHECK BY:	ENG. APPR.: L. SOROKA 3/7/06
DATE: 12-27-2005	RELEASE DATE:	Q.A. APPR.: A. KAPLAN 3/8/06
SCALE: 1:2	DO NOT SCALE PRINT	MFG. APPR.: J. SZOLYGA 3/7/06
TOLERANCE UNLESS OTHERWISE SPECIFIED: XX: +/- .020 XXX: +/- .005 ANGLES: +/- 1 DEGREE		CONFIDENTIAL: THIS DOCUMENT CONTAINS CONFIDENTIAL INFORMATION AND MAY NOT BE COPIED OR DIVULGED WITHOUT WRITTEN CONSENT OF CRITICARE SYSTEMS, INC.
TITLE: CHASSIS BOTTOM ASSEMBLY		PART NO.: 92799A001
DIST: 302		REV.: 7
SHEET 1 OF 1		

REVISIONS			
REV.	DATE	DESCRIPTION	BY
1	04-17-07	SEE ECN #9166	SC

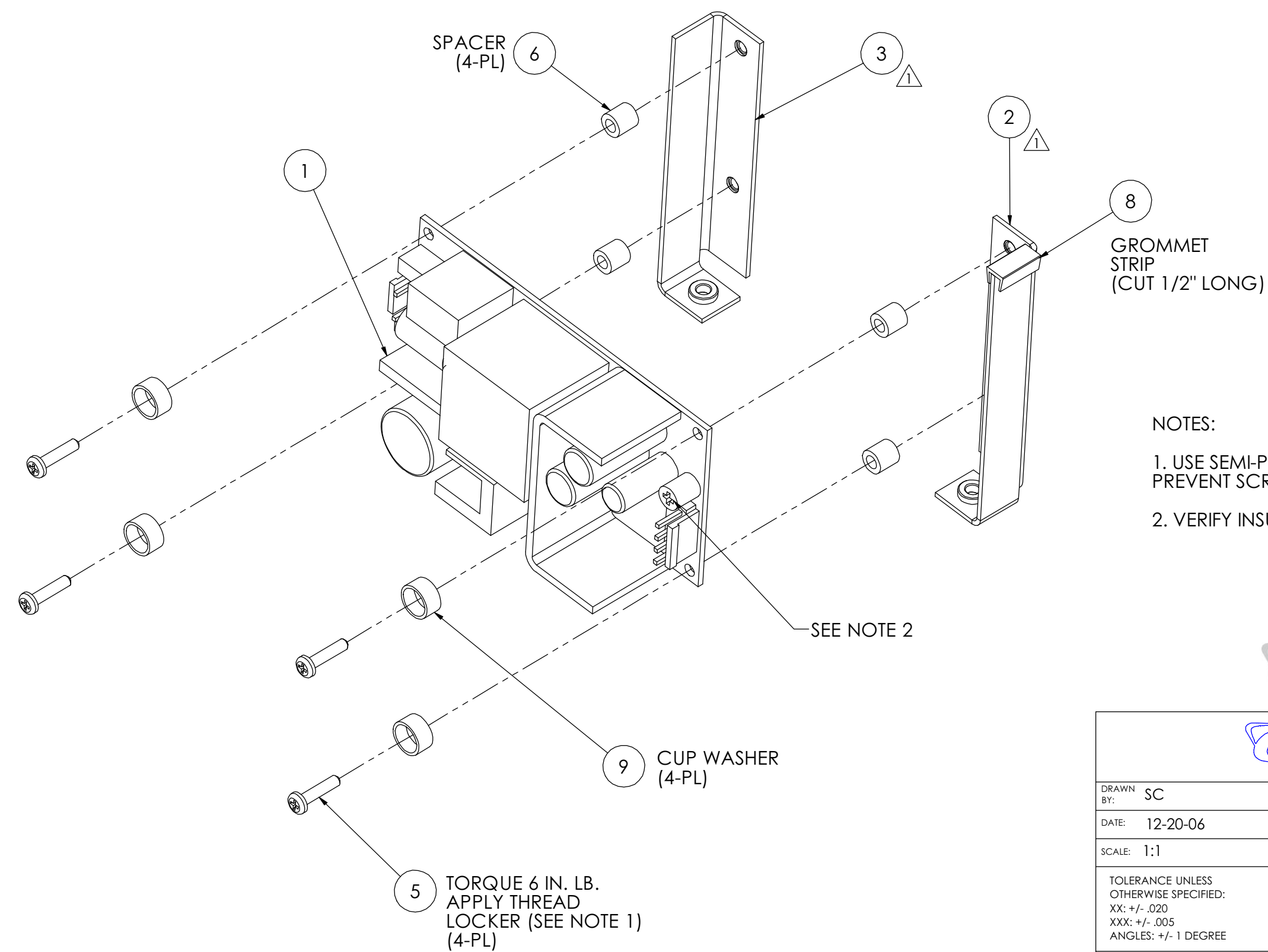

- NOTES:
1. USE SEMI-PERMANENT THREAD LOCKER (ITEM 7) TO PREVENT SCREWS (ITEM 5) FROM LOOSENING.
 2. VERIFY INSULATING VARNISH ON SVR1 OF POWER SUPPLY.

RELEASED DOCUMENT **CRITICARE SYSTEMS, INC.** SW

CRITICARE SYSTEMS, INC.		
DRAWN BY: SC	CHECK BY:	ENG. APPR.: S. Coogan 02/28/07
DATE: 12-20-06	RELEASE DATE:	Q.A. APPR.: L. Penton 03-01-07
SCALE: 1:1	DO NOT SCALE PRINT	MFG. APPR.: K. Hawver 03-01-07
TOLERANCE UNLESS OTHERWISE SPECIFIED: XX: +/- .020 XXX: +/- .005 ANGLES: +/- 1 DEGREE		CONFIDENTIAL: THIS DOCUMENT CONTAINS CONFIDENTIAL INFORMATION AND MAY NOT BE COPIED OR DIVULGED WITHOUT WRITTEN CONSENT OF CRITICARE SYSTEMS, INC.
TITLE: POWER SUPPLY WITH BRACKETS		PART NO.: 95710A003
DIST: 302		REV.: 1
SHEET 1 OF 1		

REVISIONS			
REV.	DATE	DESCRIPTION	BY
1	5/15/06	SEE ECN #8842	DBL
2	6/09/06	SEE ECN #8882	LBS
3	09/05/06	SEE ECN #8946	RWK
4	01/26/07	SEE ECN #9079	SC
5	04/18/07	SEE ECN #9166	SC
6	05/04/07	SEE ECN #9190	SC
7	6/20/09	SEE ECN #10416	DBL

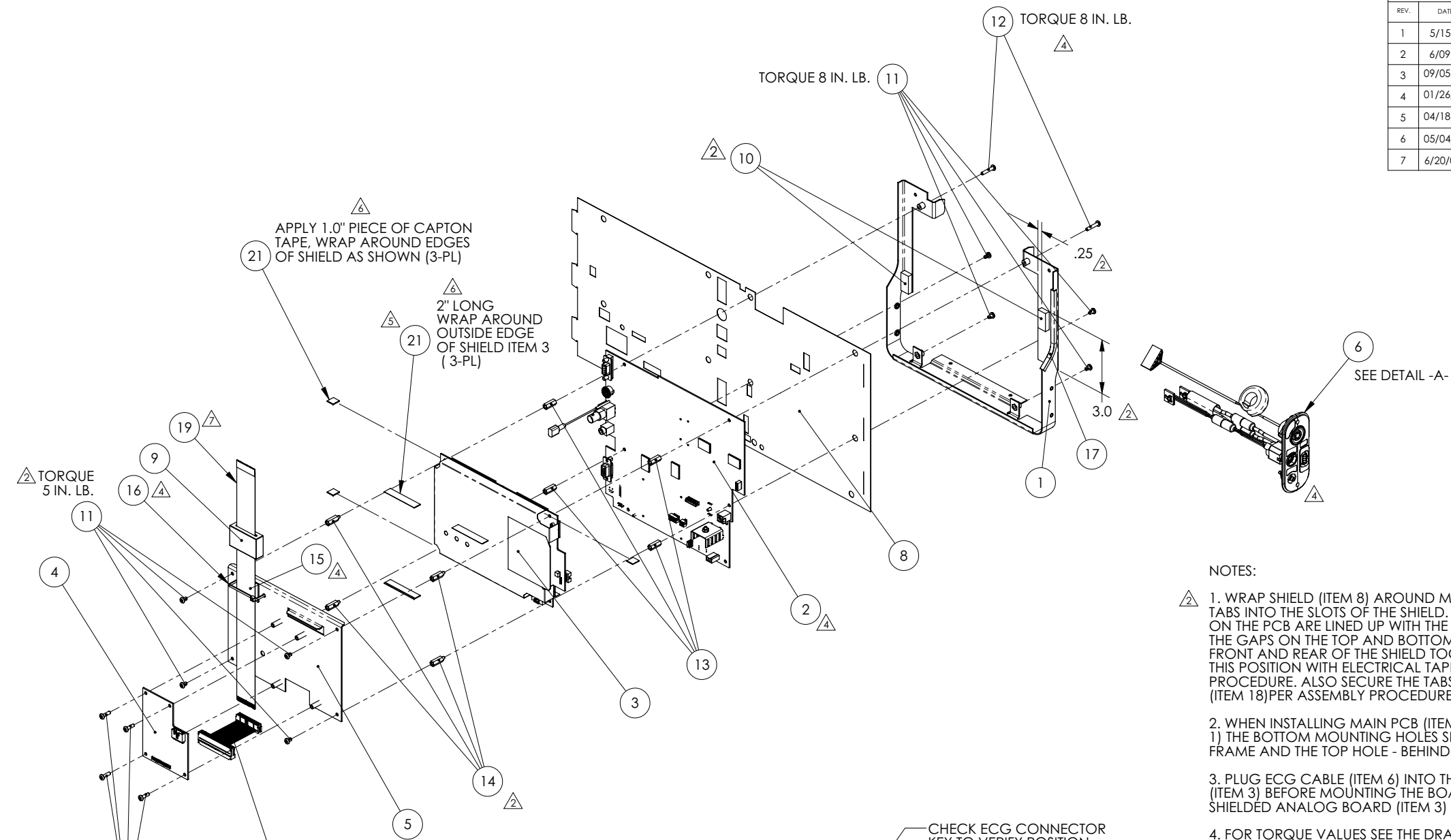

NOTES:

- 1. WRAP SHIELD (ITEM 8) AROUND MAIN PCB (ITEM 2) AND LOCK TABS INTO THE SLOTS OF THE SHIELD. MAKE SURE ALL CONNECTORS ON THE PCB ARE LINED UP WITH THE OPENINGS IN THE SHIELD. CLOSE THE GAPS ON THE TOP AND BOTTOM OF THE SHIELD BY BRINGING FRONT AND REAR OF THE SHIELD TOGETHER AND SECURE THEM IN THIS POSITION WITH ELECTRICAL TAPE (ITEM 18) PER ASSEMBLY PROCEDURE. ALSO SECURE THE TABS WITH THE ELECTRICAL TAPE (ITEM 18) PER ASSEMBLY PROCEDURE.
- 2. WHEN INSTALLING MAIN PCB (ITEM 2) ON THE FRAME MAIN (ITEM 1) THE BOTTOM MOUNTING HOLES SHOULD BE IN FRONT OF THE FRAME AND THE TOP HOLE - BEHIND THE FRAME.
- 3. PLUG ECG CABLE (ITEM 6) INTO THE SHIELDED ANALOG BOARD (ITEM 3) BEFORE MOUNTING THE BOARD. ROUTE CABLE BETWEEN SHIELDED ANALOG BOARD (ITEM 3) AND MAIN PCB (ITEM 2).
- 4. FOR TORQUE VALUES SEE THE DRAWING.
- 5. WITH A PERMANENT MARKER COPY THE SERIAL NUMBER OF THE MAIN PCB (ITEM #2) ONTO BOTH SIDES OF SHIELD (ITEM #8). THE SERIAL NUMBER MARKING SHOULD BE NEAR THE EDGE THAT IS VISIBLE AFTER ASSEMBLY. THE FIRST SHOULD BE BELOW THE PRINTER CABLE CONNECTOR, THE SECOND, ON THE OPPOSITE SIDE, NEAR THE RS232 CONNECTOR.
- 6. CONNECT THE REMAINING CABLES FROM (ITEM 6) TO REMAINING CONNECTORS.

CHECK ECG CONNECTOR KEY TO VERIFY POSITION AS SHOWN

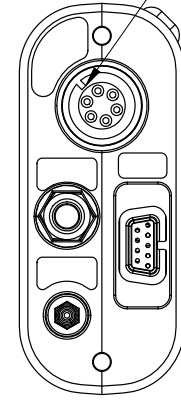

DETAIL -A- (NTS)

SW



DRAWN BY: L. SOROKA	CHECK BY:	ENG. APPR.: L. SOROKA 2/16/06
DATE: 01-03-2006	RELEASE DATE:	Q.A. APPR.: A. KAPLAN 3/8/06
SCALE: 1:4	DO NOT SCALE PRINT	MFG. APPR.: J. SZOLYGA 1/9/06
TOLERANCE UNLESS OTHERWISE SPECIFIED: XX: +/- .020 XXX: +/- .005 ANGLES: +/- 1 DEGREE		CONFIDENTIAL: THIS DOCUMENT CONTAINS CONFIDENTIAL INFORMATION AND MAY NOT BE COPIED OR DIVULGED WITHOUT WRITTEN CONSENT OF CRITICARE SYSTEMS, INC.
TITLE: CHASSIS MAIN ASSEMBLY		PART NO.: 92801A001
DIST: 302		REV.: 7
		SHEET 1 OF 1

REVISIONS			
REV.	DATE	DESCRIPTION	BY
1	2/25/09	SEE ECN #10251	DBL

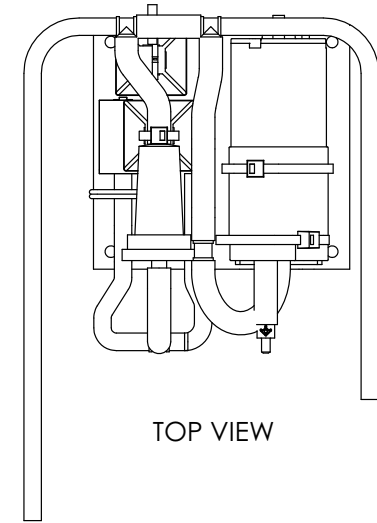
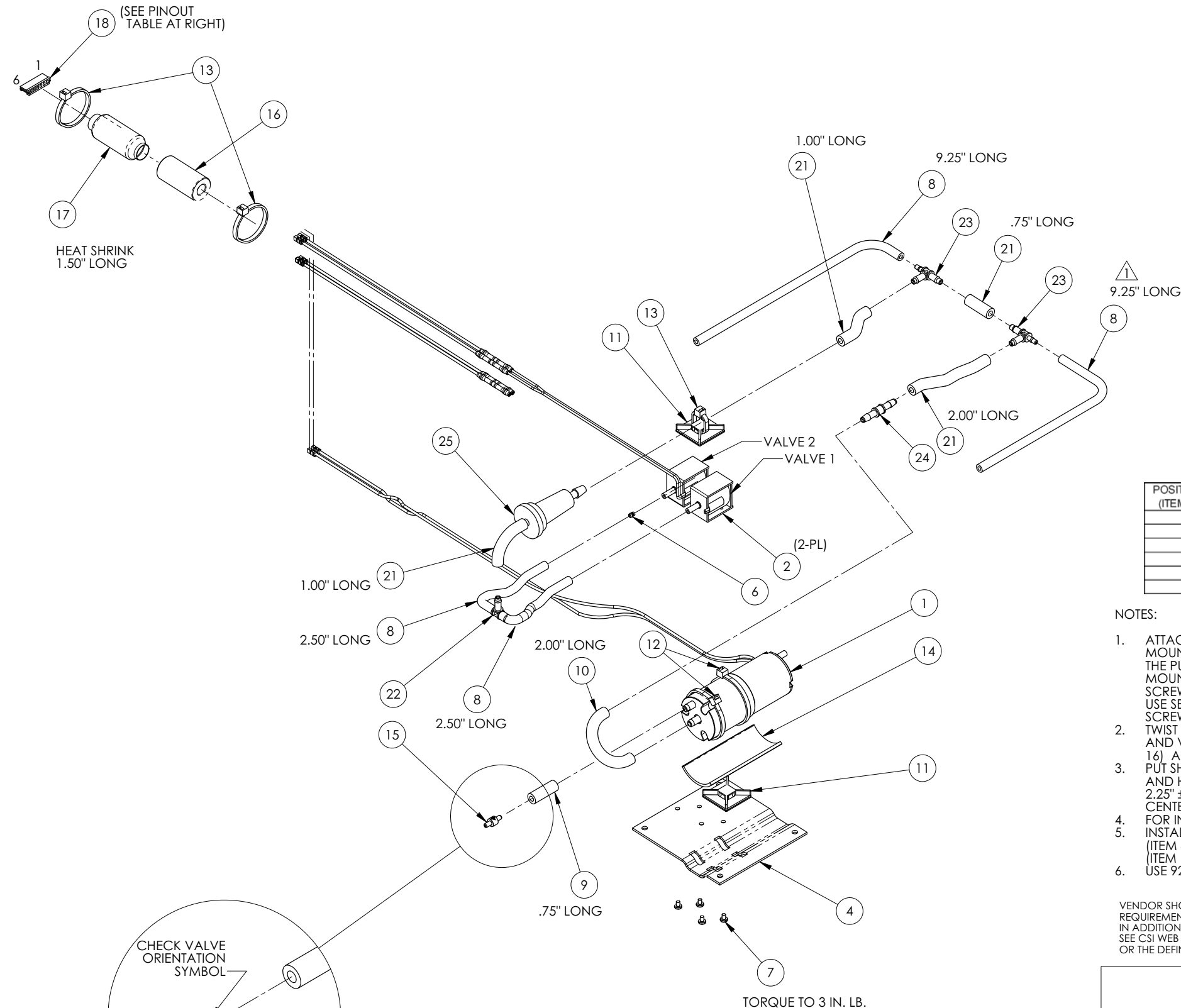

POSITION NUMBER (ITEM 18 PINOUT)	WIRE INSERTED
1	PUMP POSITIVE (ITEM 1, RED WIRE)
2	PUMP NEGATIVE (ITEM 1, BLACK WIRE)
3	VALVE 1 (ITEM 2, SEE DRAWING)
4	VALVE 1 (ITEM 2, SEE DRAWING)
5	VALVE 2 (ITEM 2, SEE DRAWING)
6	VALVE 2 (ITEM 2, SEE DRAWING)

NOTES:

- ATTACH FOAM TAPE (ITEM 14) TO THE PUMP (ITEM 1) AND MOUNT PUMP (ITEM 1) ONTO THE BRACKET (ITEM 4). SECURE THE PUMP TO THE BRACKET USING CABLE TIES (ITEM 12). MOUNT BOTH VALVES (ITEM 2) TO THE BRACKET USING SCREWS (ITEM 7). TORQUE IS SPECIFIED ON THE DRAWING. USE SEMI-PERMANENT THREAD LOCKER (ITEM 20) ON THE SCREWS.
- TWIST ALL VALVES' WIRES TOGETHER. PUT WIRES FROM PUMP AND VALVES (ITEMS 1 AND 2) THROUGH FERRITE BEADS (ITEM 16) AND SHRINK TUBING (ITEM 17).
- PUT SHRINK TUBING (ITEM 17) OVER FERRITE BEADS (ITEM 16) AND HEAT SHRINK IT. FERRITE BEADS SHOULD BE POSITIONED $2.25" \pm .25"$ FROM THE CONNECTOR HOUSING (ITEM 18) AND CENTERED IN THE SHRINK TUBING.
- FOR INSERTING WIRES INTO HOUSING (ITEM 18) SEE TABLE.
- INSTALL HOLDER TIE WRAP (ITEM 11) ONTO THE BRACKET (ITEM 4) SECURE THE WIRES TO THE HOLDER WITH CABLE TIE (ITEM 13).
- USE 92797PA002 FOR ASSEMBLY.

VENDOR SHOULD COMPLY WITH THE FOLLOWING CSI QUALITY REQUIREMENTS: Q1, Q2, Q4, Q5, Q6, Q7, Q10, Q11 AND Q16. IN ADDITION THE QUALITY REQUIREMENTS Q9 AND Q17 APPLY. SEE CSI WEB SITE (www.csiusa.com/pdf/QA_Requirements.pdf) OR THE DEFINITION OF THE QUALITY REQUIREMENTS.

SW

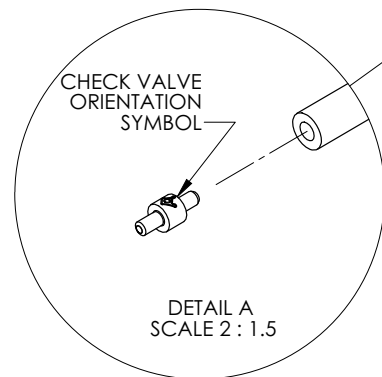

RELEASED DOCUMENT
CRITICARE SYSTEMS, INC.

CSI CRITICARE SYSTEMS, INC.		
DRAWN BY: SC	CHECK BY:	ENG. APPR.:
DATE: 08-09-07	RELEASE DATE:	Q.A. APPR.:
SCALE: 1:1	DO NOT SCALE PRINT	MFG. APPR.:
TOLERANCE UNLESS OTHERWISE SPECIFIED: XX: +/- .020 XXX: +/- .005 ANGLES: +/- 1 DEGREE		CONFIDENTIAL: THIS DOCUMENT CONTAINS CONFIDENTIAL INFORMATION AND MAY NOT BE COPIED OR DIVULGED WITHOUT WRITTEN CONSENT OF CRITICARE SYSTEMS, INC.
TITLE: ASSEMBLY NIBP CHASSIS		PART NO.: 92797A002
		REV. 1
DIST: -		SHEET 1 OF 1

REVISIONS			
REV.	DATE	DESCRIPTION	BY
1	03/10/07	SEE ECN #9139	SC
2	04/19/07	SEE ECN #9166	SC
3	02/16/08	SEE ECN #10061	SC
4	09/19/08	SEE ECN #10240	RWK
5	2/17/09	SEE ECN #10343	DBL

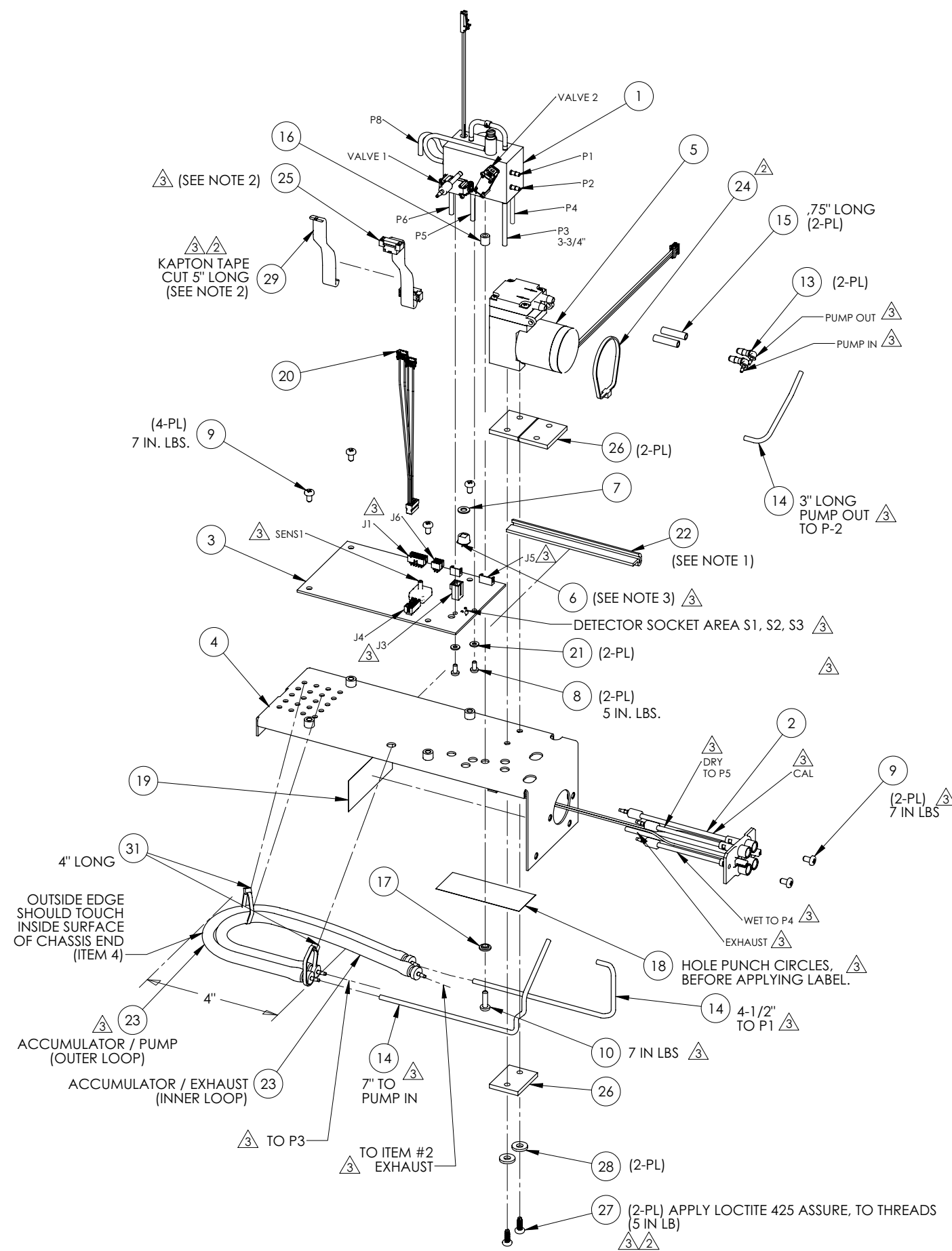

ITEM	DESCRIPTION	MANIFOLD BLOCK LOCATION
1	P1	TO ACCUMULATOR/PUMP, TO PUMP IN
2	P2	TO PUMP OUT
3	P3	EXHAUST, TO ACCUMMULATOR/EXHAUST
4	P4	WET, TO PNEUMATIC RECEPTACLE PLATE AY., WET
5	P5	DRY, TO PNEUMATIC RECEPTACLE PLATE AY., DRY
6	P6	CAL, TO PNEUMATIC RECEPTACLE PLATE AY., CAL
7	P7	TO NEEDLE VALVE AY., ON TOP OF BLOCK
8	P8	TO "SENS1", PSI DETECTOR MOUNTED ON PCB
9	P9	TO P10
10	P10	TO P9
11	P11	TO P12
12	P12	TO P11
13	P13	VENT
14	V1	VALVE #1, MOUNT LOCATION
15	V2	VALVE #2, MOUNT LOCATION
16	N1	NEEDLE VALVE, MOUNT LOCATION
17	L1	LAMP AY., MOUNT LOCATION

NOTES:

1. APPLY (2) 4" LONG PIECES OF FOAM TAPE (ITEM 22) ALONG EDGE OF CHASSIS (ITEM 4) AS SHOWN.
2. ASSEMBLE ITEM 25 & 29. CHECK FOR FIT. TRANSFER TO CONVERSION DEPT.
3. CUT 3 LEADS OF DETECTOR (ITEM 6) TO .100" LONG FROM BOTTOM EDGE OF DETECTOR, USE TOOL #T10008.

VENDOR SHOULD COMPLY WITH THE FOLLOWING CSI QUALITY REQUIREMENTS: Q1, Q2, Q4, Q5, Q6, Q7, Q10, Q11 AND Q16. IN ADDITION THE QUALITY REQUIREMENTS Q9, Q13 AND Q17 APPLY. SEE CSI WEB SITE (www.csiusa.com/pdf/QA_Requirements.pdf) FOR THE DEFINITION OF THE QUALITY REQUIREMENTS.

SW

CRITICARE SYSTEMS, INC.

DRAWN BY: SC	CHECK BY:	ENG. APPR.: S. Coogan 01-31-07
DATE: 01-11-07	RELEASE DATE:	Q.A. APPR.: A. Kaplan 02-02-07
SCALE: NTS	DO NOT SCALE PRINT	MFG. APPR.: K. Hawver 02-02-07
TOLERANCE UNLESS OTHERWISE SPECIFIED: XX: +/- .020 XXX: +/- .005 ANGLES: +/- 1 DEGREE		CONFIDENTIAL: THIS DOCUMENT CONTAINS CONFIDENTIAL INFORMATION AND MAY NOT BE COPIED OR DIVULGED WITHOUT WRITTEN CONSENT OF CRITICARE SYSTEMS, INC.
TITLE: ASSEMBLY, CO2 MODULE, INTERNAL		PART NO.: 92811A001
		REV.: 5
		DIST: - SHEET 1 OF 1

REVISIONS			
REV.	DATE	DESCRIPTION	BY
1	04/17/07	SEE ECN #9166	SC
2	05/18/08	SEE ECN #10227	RWK
3	12/17/08	SEE ECN #10343	DBL
4	4/1/09	SEE ECN #10252	DBL
5	5/29/09	SEE ECN #10439	DBL

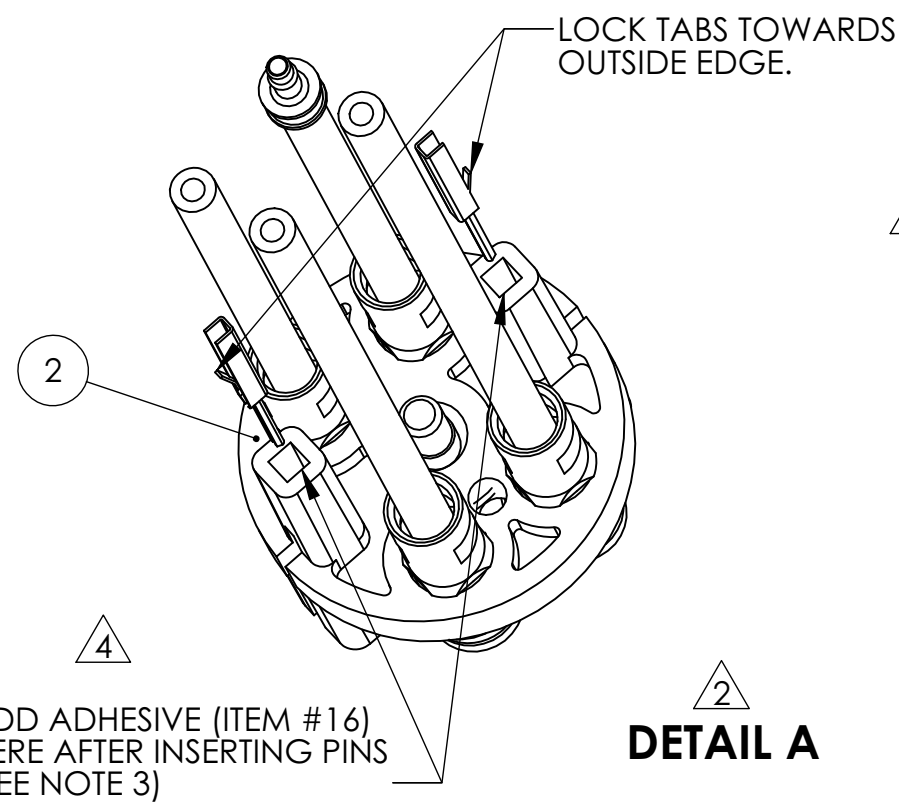
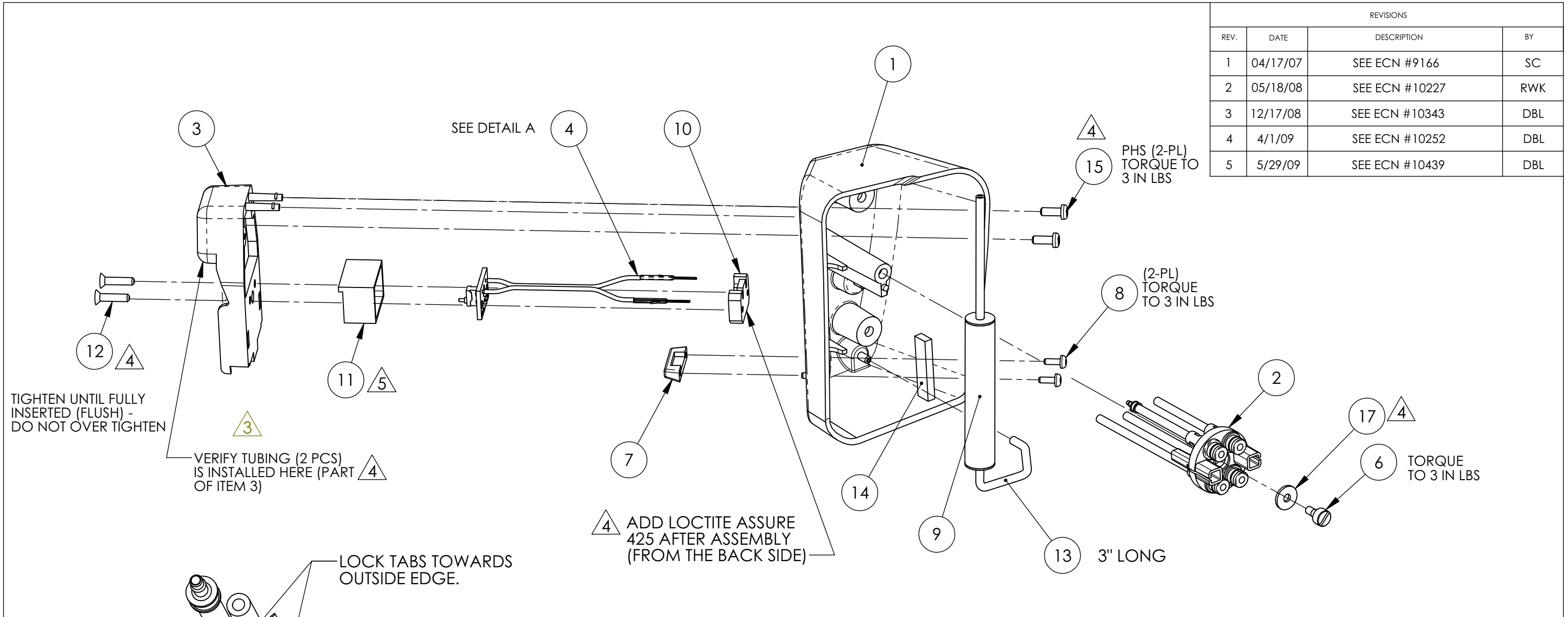

- 2 Recommended Build Sequence**
- Item 4, male crimp pin ends, install into Item 2, 2 pcs as shown on print. Lock tabs must be towards the outside edge, must snap into place.
 - Insert mating part, pn 91784A001, to Item 2 in order to center the male crimp pin of Item 4. Check that the lock tabs are still holding, tabs must be towards the outside edge, must snap into place.
 - Add adhesive, Item 16, with a syringe to the openings of Item 2, from where the wires stickout of Item 2, fill to the end of the cavity, 2 places.
 - After adhesive is tack free (4 hours), remove 91784A001 and install remaining items.

VENDOR SHOULD COMPLY WITH THE FOLLOWING CSI QUALITY REQUIREMENTS: Q1, Q2, Q4, Q5, Q6, Q7, Q10, Q11 AND Q16. IN ADDITION THE QUALITY REQUIREMENTS Q9, Q13 AND Q17 APPLY. SEE CSI WEB SITE (www.csiusa.com/pdf/QA_Requirements.pdf) FOR THE DEFINITION OF THE QUALITY REQUIREMENTS.

RELEASED DOCUMENT **SW**



DRAWN BY: SC		CHECK BY:	ENG. APPR.: S. Coogan 02-28-07
DATE: 01-04-07		RELEASE DATE:	Q.A. APPR.: L. Penton 03-01-07
SCALE: NTS		DO NOT SCALE PRINT	MFG. APPR.: K. Hawver 03-01-07
TOLERANCE UNLESS OTHERWISE SPECIFIED: XX: +/- .020 XXX: +/- .005 ANGLES: +/- 1 DEGREE		CONFIDENTIAL: THIS DOCUMENT CONTAINS CONFIDENTIAL INFORMATION AND MAY NOT BE COPIED OR DIVULGED WITHOUT WRITTEN CONSENT OF CRITICARE SYSTEMS, INC.	
TITLE: CO2 MODULE ASSEMBLY EXTERNAL		PART NO.: 92811A002	REV. 5
DIST: -		SHEET 1 OF 1	

REVISIONS			
REV	DATE	DESCRIPTION	BY
1	5/15/06	SEE ECH #842	DBL
2	04/13/06	SEE ECH #888	LBS
3	10/04/06	SEE ECH #8932	RWC
4	01/22/07	SEE ECH #9079	SC
5	04/17/07	SEE ECH #9166	SC
6	4/19/08	SEE ECH #10416	DBL

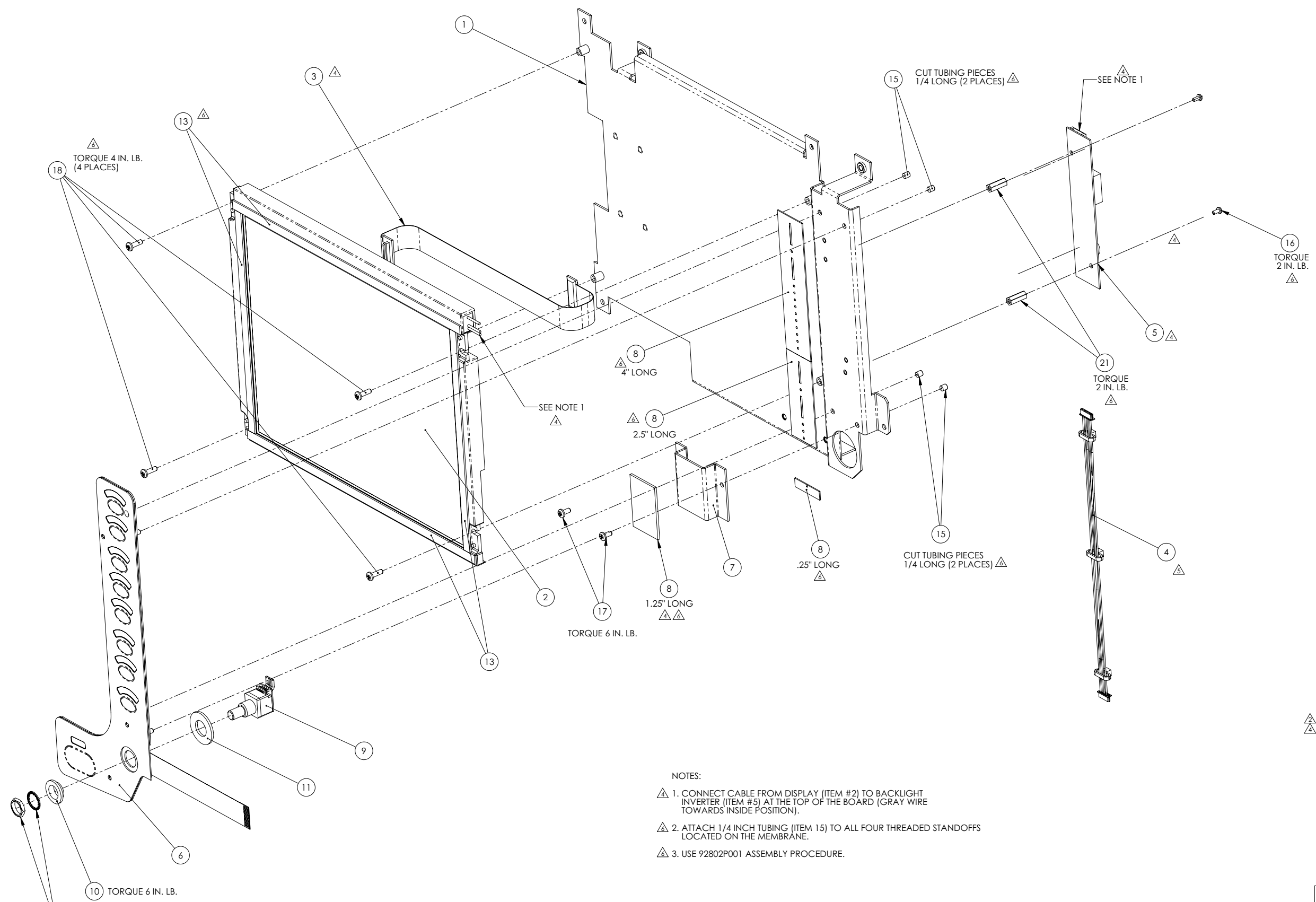

- NOTES:
- ⚠ 1. CONNECT CABLE FROM DISPLAY (ITEM #2) TO BACKLIGHT INVERTER (ITEM #5) AT THE TOP OF THE BOARD (GRAY WIRE TOWARDS INSIDE POSITION).
 - ⚠ 2. ATTACH 1/4 INCH TUBING (ITEM 15) TO ALL FOUR THREADED STANDOFFS LOCATED ON THE MEMBRANE.
 - ⚠ 3. USE 92802P001 ASSEMBLY PROCEDURE.

SW

CRITICARE SYSTEMS, INC.			
DRAWN BY: L. SOROKA	CHECK BY:	ENG. APPR.: L. SOROKA	02/16/06
DATE: 01-03-2006	RELEASE DATE:	D.A. APPR.: M. LARSEN	02/16/06
SCALE: 1:2	DO NOT SCALE PRINT	SIG. APPR.: J. SZOLYGA	01/6/06
TOLERANCE UNLESS OTHERWISE SPECIFIED: XX: +/- .020 XXX: +/- .005 ANGLES: +/- 1 DEGREE		CONFIDENTIAL: THIS DOCUMENT CONTAINS CONFIDENTIAL INFORMATION AND MAY NOT BE COPIED OR DIVULGED WITHOUT WRITTEN CONSENT OF CRITICARE SYSTEMS, INC.	
TITLE: CHASSIS DISPLAY ASSEMBLY		PART NO.: 92802A001	REV. 6
DIST: 302		SHEET 1 OF 1	

RELEASED DOCUMENT
CRITICARE SYSTEMS, INC.

REVISIONS			
REV.	DATE	DESCRIPTION	BY
1	05-15-2006	SEE ECN #8842	DBL
2	05-16-2006	SEE ECN #8850	LBS
3	01-26-2007	SEE ECN #9079	SC

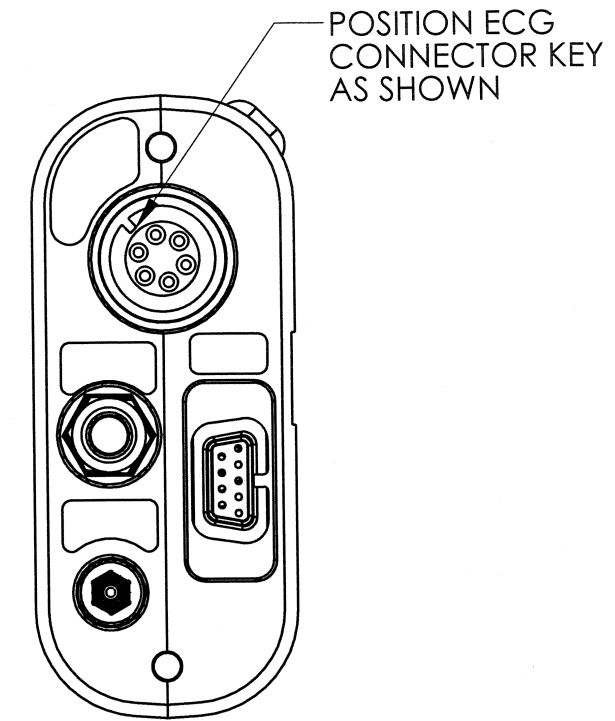
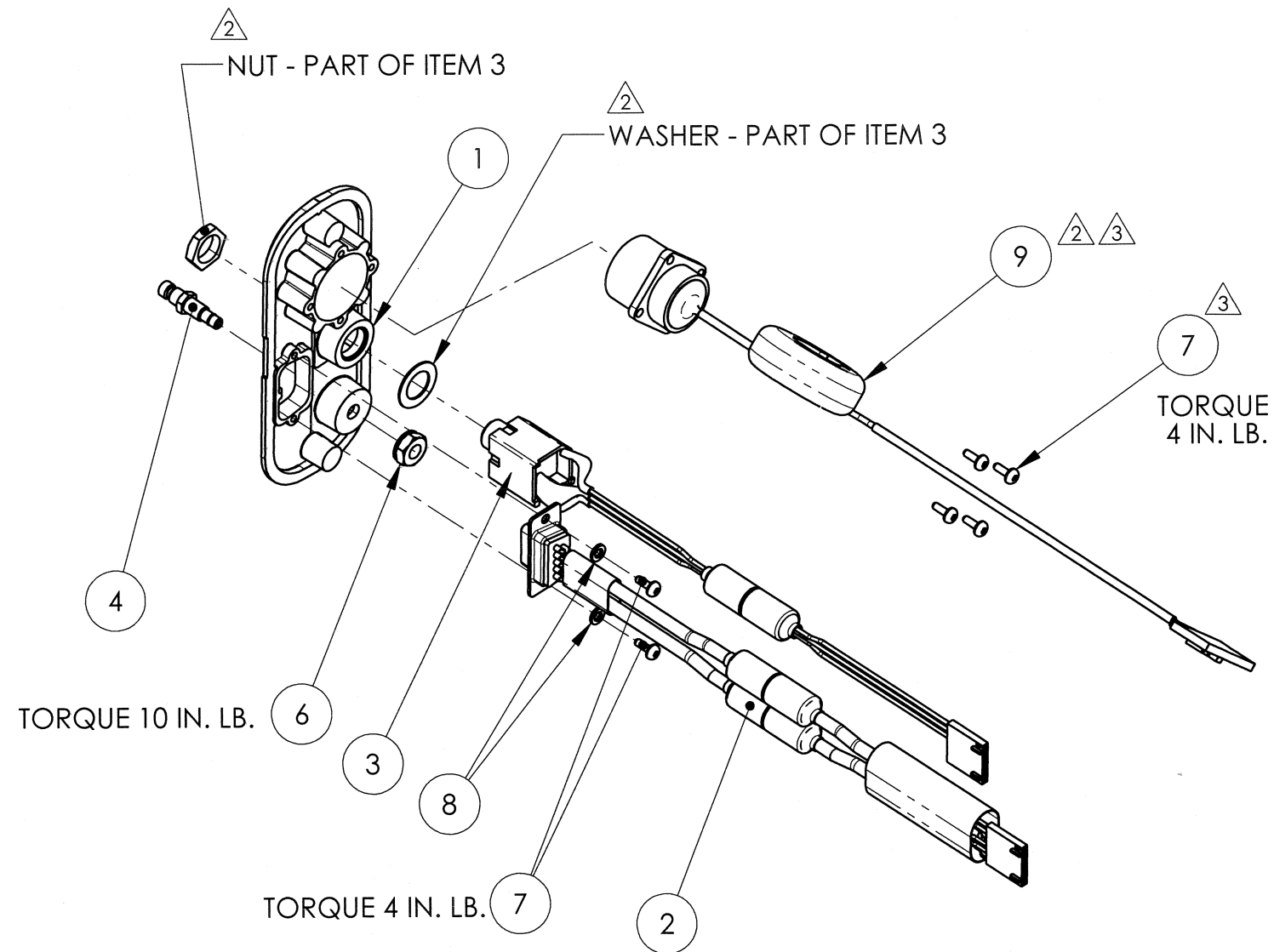

DETAIL -A- (NTS) ³

SW

NOTES:

- ² 1. INSERT NUT (PART OF ITEM 3) INTO THE CORRESPONDING RECESS OF THE INSERT PATIENT CONNECTORS (ITEM 1) AND THREAD IN TEMPERATURE CABLE (ITEM 3) HAND TIGHT. SIDE SURFACE OF THE TEMPERATURE CONNECTOR SHOULD BE PARALLEL TO THE SIDE OF THE INSERT (ITEM 1). THE WASHER (PART OF THE ITEM 3) SHOULD BE INSTALLED ON THE CONNECTOR BEFORE THREADING IT INTO THE NUT.
2. FOR TORQUE VALUES SEE DRAWING.

CS CRITICARE SYSTEMS, INC.

DRAWN BY: L. SOROKA	CHECK BY: <i>R. Full</i> 2-14-07	ENG. APPR.: L. SOROKA 1/6/06
DATE: 01-04-2006	RELEASE DATE:	Q.A. APPR.: A. KAPLAN 2/16/06
SCALE: 1:2	DO NOT SCALE PRINT	MFG. APPR.: J. SZOLYGA 1/6/06

TOLERANCE UNLESS OTHERWISE SPECIFIED:
 XX: +/- .020
 XXX: +/- .005
 ANGLES: +/- 1 DEGREE

CONFIDENTIAL: THIS DOCUMENT CONTAINS CONFIDENTIAL INFORMATION AND MAY NOT BE COPIED OR DIVULGED WITHOUT WRITTEN CONSENT OF CRITICARE SYSTEMS, INC.

TITLE: ASSEMBLY PATIENT CONNECTORS	PART NO.: 95767A001	REV.: 3
DIST: 302	SHEET 1 OF 1	

REVISIONS			
REV.	DATE	DESCRIPTION	BY
1	05/15/06	SEE ECN #8842	DBL
2	01/26/07	SEE ECN #9079	SC
3	6/19/09	SEE ECN #10416	DBL

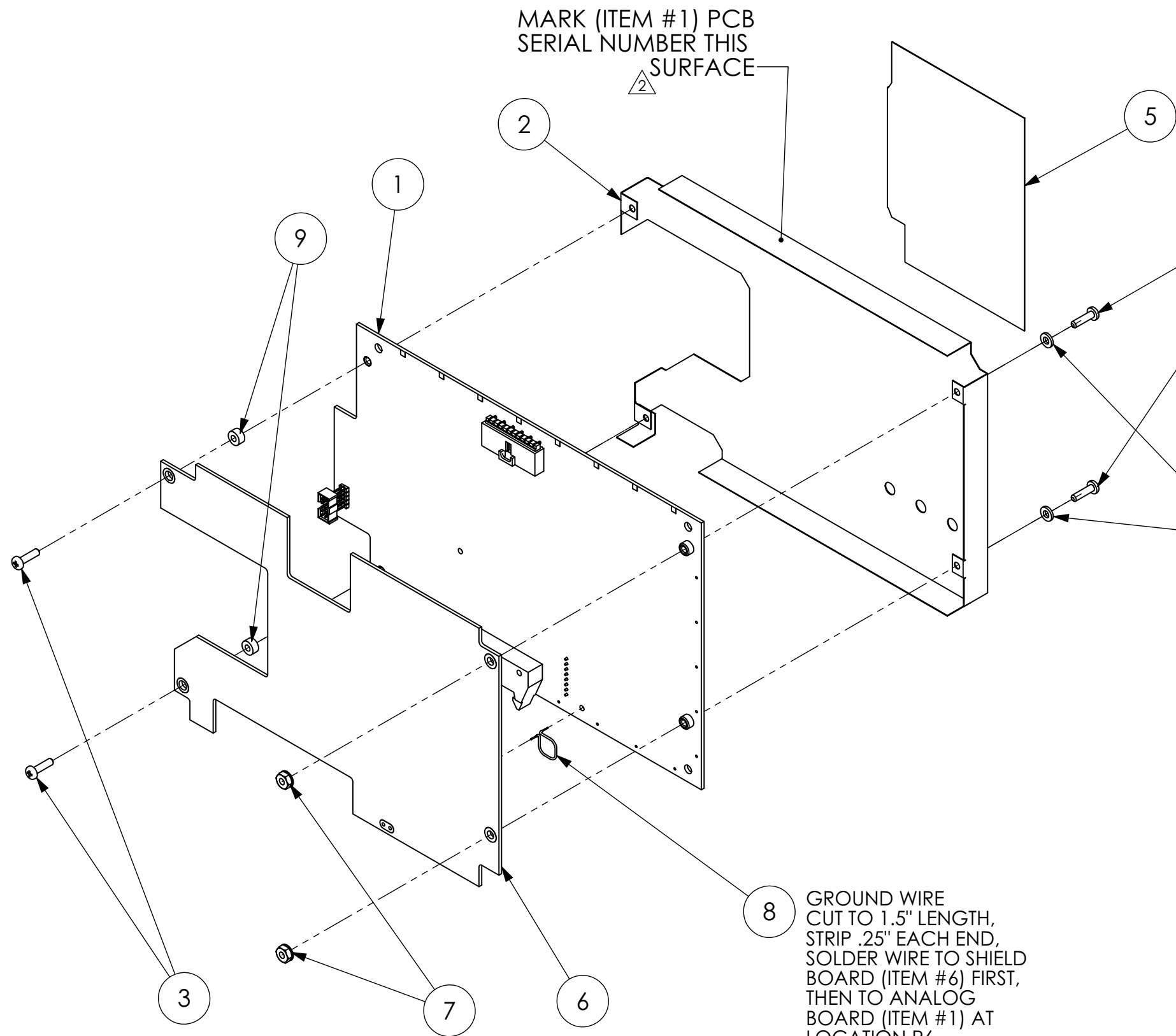

TORQUE 5 IN. LB.

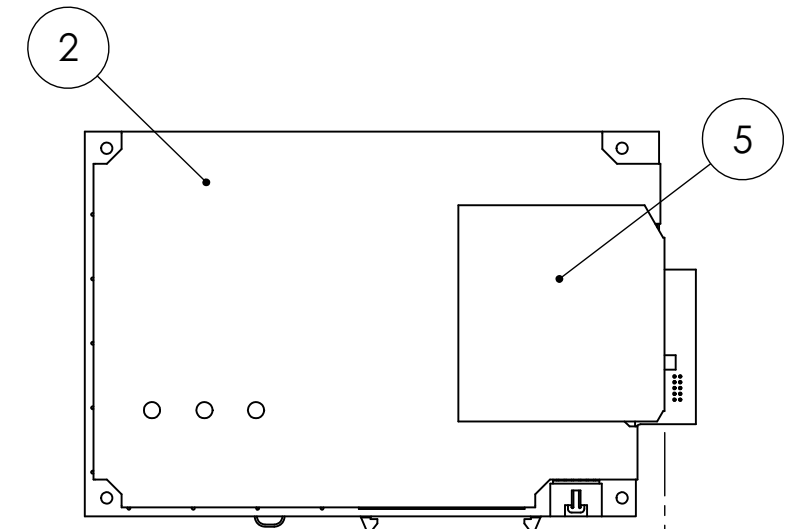

ALIGN EDGE OF INSULATOR
ITEM #5 WITH EDGE OF BOARD
AS SHOWN.

SW

TORQUE 5 IN. LB.

8 GROUND WIRE
CUT TO 1.5" LENGTH,
STRIP .25" EACH END,
SOLDER WIRE TO SHIELD
BOARD (ITEM #6) FIRST,
THEN TO ANALOG
BOARD (ITEM #1) AT
LOCATION P6.



DRAWN BY: DBL	CHECK BY:	ENG. APPR.: L. SOROKA 2/24/06
DATE: 2/24/06	RELEASE DATE:	Q.A. APPR.: M. LARSEN 2/24/06
SCALE: 1:1	DO NOT SCALE PRINT	MFG. APPR.: K. HAWVER 2/24/06

TOLERANCE UNLESS
OTHERWISE SPECIFIED:
XX: +/- .020
XXX: +/- .005
ANGLES: +/- 1 DEGREE

CONFIDENTIAL: THIS DOCUMENT CONTAINS CONFIDENTIAL
INFORMATION AND MAY NOT BE COPIED OR DIVULGED
WITHOUT WRITTEN CONSENT OF CRITICARE SYSTEMS, INC.

TITLE: ANALOG BOARD ASSEMBLY WITH FLEXIBLE SHIELD	PART NO.: 91353A003	REV.: 3
DIST: 302	SHEET 1 OF 1	

REVISIONS			
REV.	DATE	DESCRIPTION	BY
1	5/15/06	SEE ECN #8842	DBL
2	1/18/07	SEE ECN #9079	SC

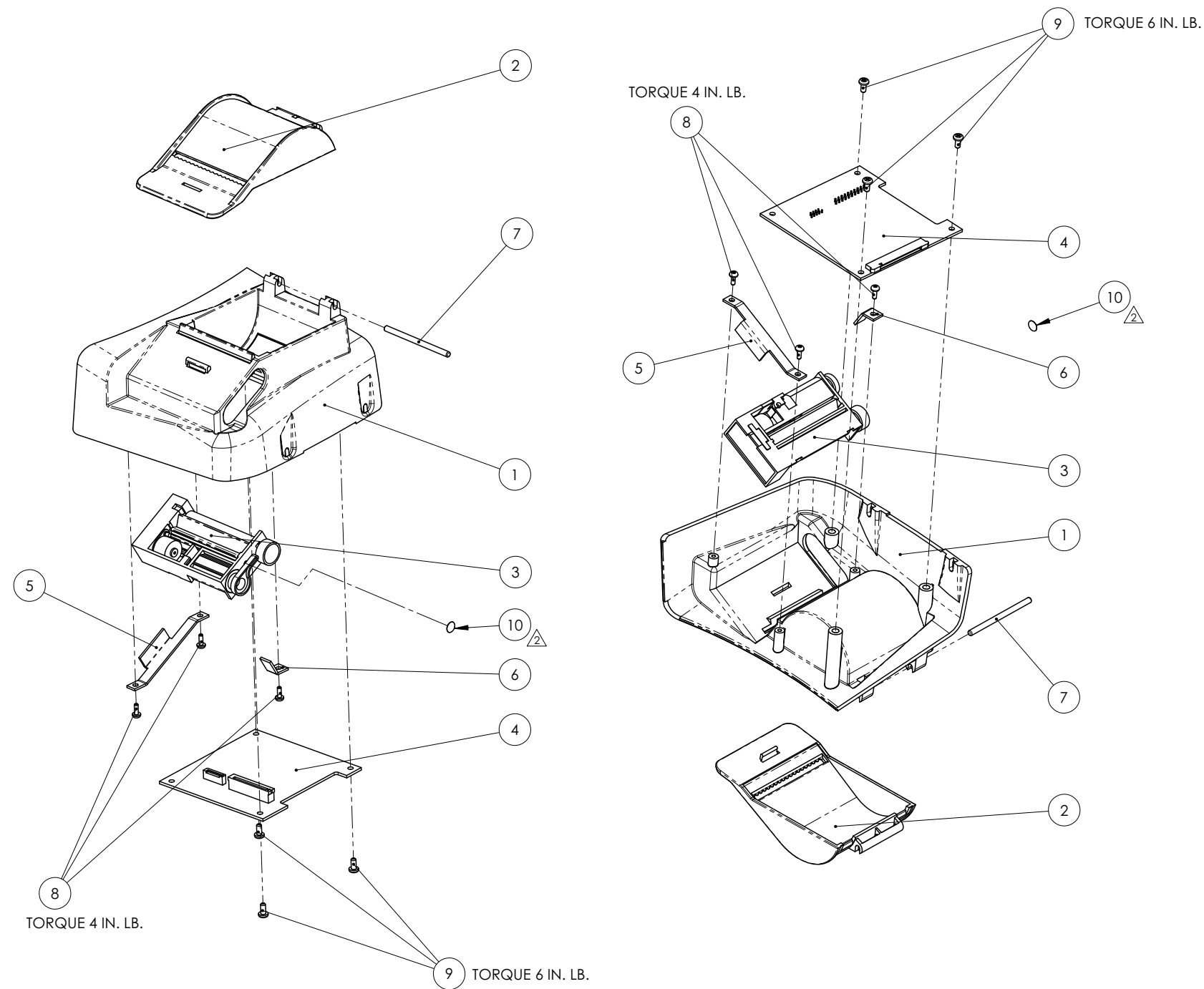

SW

CRITICARE SYSTEMS, INC.		
DRAWN BY: L. SOROKA	CHECK BY:	ENG. APPR.: L. SOROKA 3/7/06
DATE: 01-05-2006	RELEASE DATE:	Q.A. APPR.: A. KAPLAN 3/8/09
SCALE: 1:2	DO NOT SCALE PRINT	MFG. APPR.: J. SZOLYGA 3/9/06
TOLERANCE UNLESS OTHERWISE SPECIFIED: XX: +/- .020 XXX: +/- .005 ANGLES: +/- 1 DEGREE		CONFIDENTIAL: THIS DOCUMENT CONTAINS CONFIDENTIAL INFORMATION AND MAY NOT BE COPIED OR DIVULGED WITHOUT WRITTEN CONSENT OF CRITICARE SYSTEMS, INC.
TITLE: PRINTER MODULE ASSEMBLY		PART NO.: 92804A001
DIST: 302		REV. 2
SHEET 1 OF 1		

REVISIONS			
REV.	DATE	DESCRIPTION	BY
1	3/15/07	SEE ECN #9135	DBL
2	6/15/07	SEE ECN #10032	DBL
3	04/09/08	SEE ECN #10207	RWK
4	5/23/08	SEE ECN #10233	DBL
5	7/8/09	SEE ECN 10463	MJO

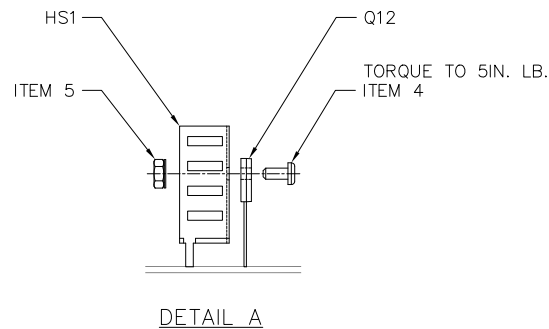
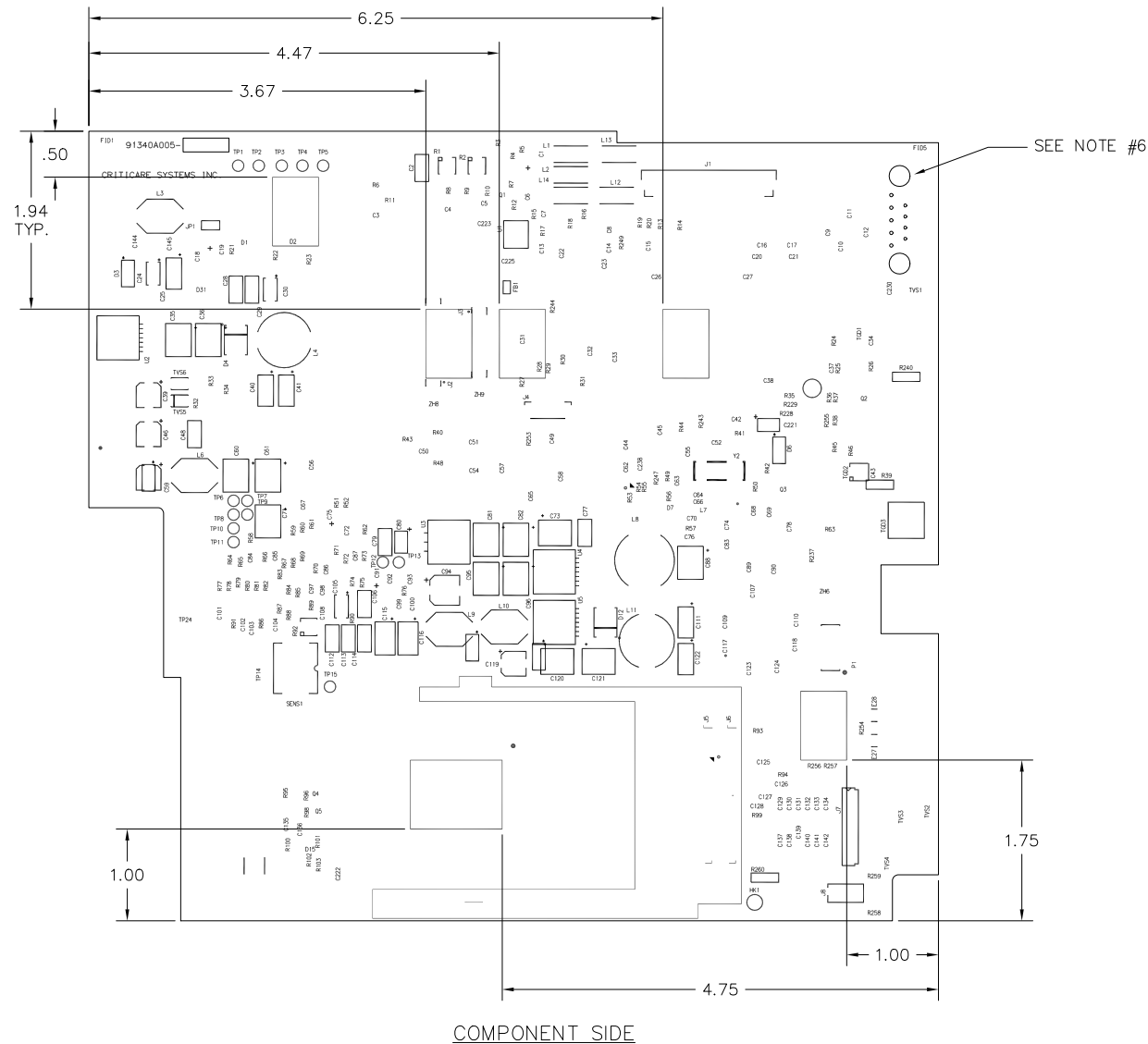
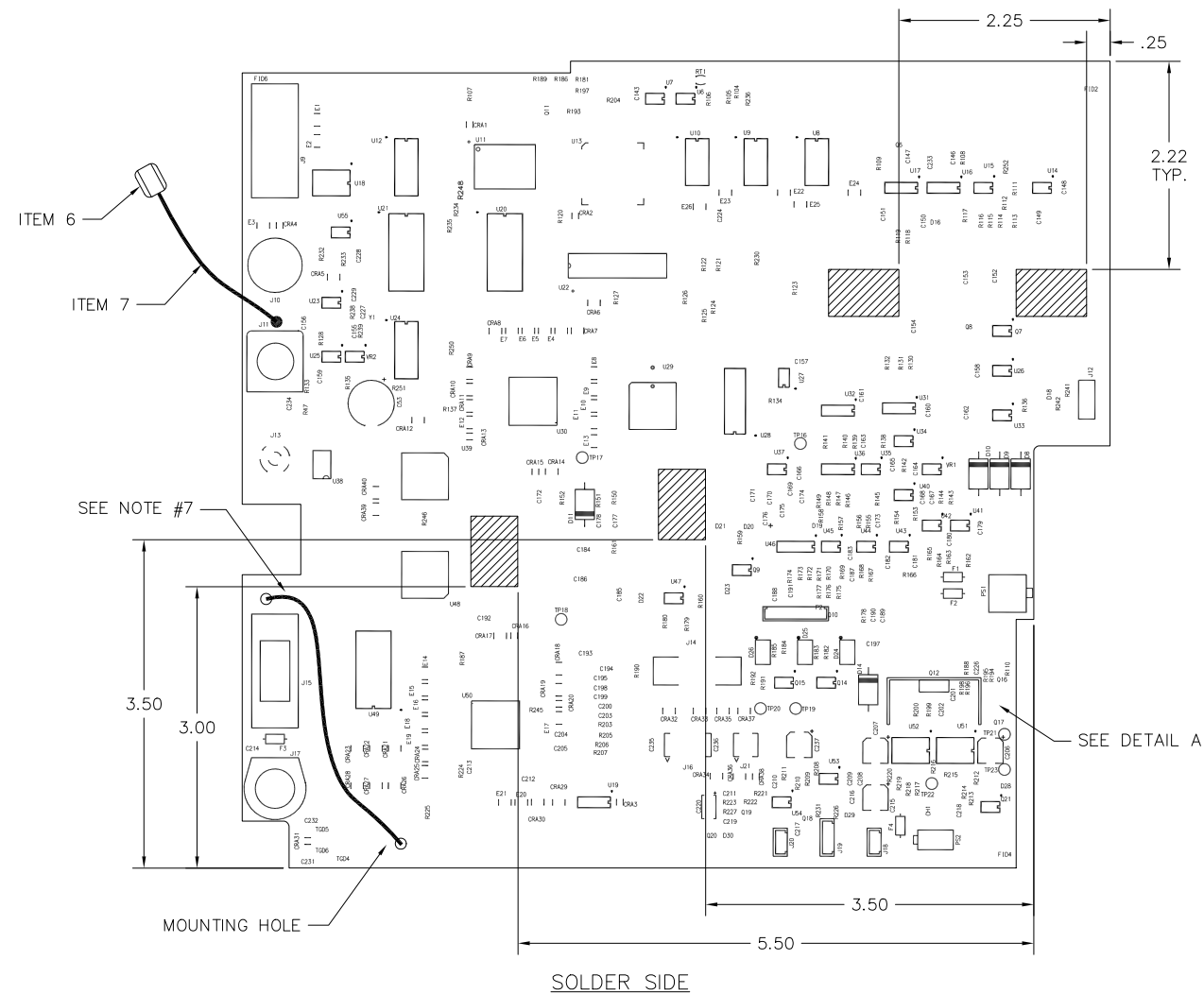

NOTES:

- 1.) FINISHED BOARD SHALL MEET CURRENT IPC-A-610 STANDARDS, CLASS II.
- 2.) BARE BOARD 83599B005 TO BE USED ON ASSEMBLY 91340A005.
- 3.) CSI RESERVES THE RIGHT TO INSPECT THIS ITEM AT THE VENDORS FACILITY. VENDORS INSPECTION SYSTEM AND MANUFACTURING PROCESS ARE SUBJECT TO REVIEW/APPROVAL, VERIFICATION AND ANALYSIS BY AUTHORIZED CSI REPRESENTATIVES. ALL CHANGES IN DESIGN, COMPONENTS, PROCESSES OR FABRICATION MUST BE AUTHORIZED IN WRITING BY CSI PRIOR TO IMPLEMENTATION. ALL DEVIATIONS FROM DRAWINGS, SPECIFICATIONS, OR OTHER REQUIREMENTS MUST BE REPORTED TO CSI FOR APPROVAL PRIOR TO SHIPMENT. ALL RAW MATERIALS USED TO PRODUCE THIS PART SHALL BE TRACEABLE TO AT LEAST A LOT LEVEL. ALL TRACEABILITY AND INSPECTION RECORDS MUST BE IDENTIFIABLE TO THE RAW MATERIALS, PARTS, ASSEMBLIES, OR DEVICES TO WHICH THEY APPLY AND SHALL BE AVAILABLE UPON REQUEST OR AUDIT BY CSI REPRESENTATIVE.
- FIRST ARTICLES MUST BE INSPECTED AND ACCEPTED BY A CSI QUALITY REPRESENTATIVE PRIOR TO A PRODUCTION SHIPMENT, UNLESS OTHERWISE AUTHORIZED BY CSI. THE FIRST ARTICLES MUST BE INSPECTED AND OR TESTED FOR COMPLIANCE TO THE REQUIREMENT OF APPLICABLE ENGINEERING DRAWINGS AND SPECIFICATIONS. FIRST ARTICLES MUST BE SO MARKED AND IDENTIFIED WITH A PART NUMBER. ANY MAJOR TOOLING, PROCESS, OR COMPONENT CHANGE WILL REQUIRE A NEW FIRST ARTICLE EVALUATION.
- EACH LOT OF PARTS SHALL BE ACCOMPANIED BY A LEGIBLE COPY OF A CERTIFICATE OF COMPLIANCE LISTING THE DRAWING, SPECIFICATION, PROCESS AND APPLICABLE REVISION TO WHICH THE PARTS COMPLY AND BE SIGNED OFF BY THE VENDORS QA REPRESENTATIVE.
- EACH ASSEMBLY SHALL BE IDENTIFIED WITH THE CSI PART NUMBER AND REVISION FOR THE ASSEMBLY, AND A UNIQUE SERIAL NUMBER IN HUMAN-READABLE FORMAT. SERIAL NUMBERS SHALL NOT BE DUPLICATED. THE FORMAT FOR THE SERIAL NUMBER SHALL CONTAIN AT LEAST 2 ALPHABETICAL PREFIX CHARACTERS THAT ARE RELEVANT TO THE VENDOR TO DISTINGUISH BETWEEN MULTIPLE VENDORS. THE ASSEMBLY PART NUMBER, REVISION AND SERIAL NUMBER SHALL ALSO BE LABELED ON THE PCB ASSEMBLY IN BARCODE FORMAT USING CODE 39 (PREFERRED) OR CODE 128.
- 4.) CONNECTOR J9, J10, J11, J13 AND J15 MUST BE MOUNTED STRAIGHT AND FLUSH TO PCB.
- 5.) ORIENT J11 CONNECTOR AS SHOWN
- 6.) INSERT SCREW (ITEM 2) INTO HOLE OF DB9 CONNECTOR AS SHOWN. TORQUE TO 5 IN. LBS.
- 7.) INSERT WIRE (ITEM #1) INTO HOLES ABOVE J15 AND TO THE RIGHT OF LOWER MOUNTING HOLE AS SHOWN.
- 8.) INSERT SCREW (ITEM 4) THROUGH HOLES IN Q12 AND HS1 AS SHOWN IN DETAIL A. ADD KEPS NUT (ITEM 5) AND TORQUE TO 5 IN. LB.
- 9.) INSERT WIRE WITH TERMINAL (ITEMS 6 & 7) INTO HOLE ABOVE J11.

VENDOR SHOULD COMPLY WITH THE FOLLOWING CSI QUALITY REQUIREMENTS: Q1, Q2, Q4, Q5, Q6, Q7, Q10, Q11 AND Q16. IN ADDITION THE QUALITY REQUIREMENTS Q9, Q13 AND Q17 APPLY. SEE CSI WEB SITE (www.csiso.com/pdf/QA_Requirements.pdf) FOR THE DEFINITION OF THE QUALITY REQUIREMENTS.



DRWN: DBL	CHECK BY:	ENG. APPR.: R. SMITH 2/8/07
DATE: 9/12/06	RELEASE DATE:	Q.A. APPR.: A. KAPLAN 2/19/07
SCALE: 1:1	DO NOT SCALE PRINT	MFG. APPR.: K. HAWVER2/19/07
TOLERANCE UNLESS OTHERWISE SPECIFIED: XX: +/- .020 XXX: +/- .005 ANGLES: +/- 1 DEGREE		CONFIDENTIAL: THIS DOCUMENT CONTAINS CONFIDENTIAL INFORMATION AND MAY NOT BE COPIED OR DIVULGED WITHOUT WRITTEN CONSENT OF CRITICARE SYSTEMS, INC.
TITLE: 8100E1/EP1 ASSEMBLY MAIN PCB BOARD	PART NO.: 91340A005	REV.: 5
DISTR:		SHEET 1 OF 1



REV	DATE	ECN #
0	12/26/06	

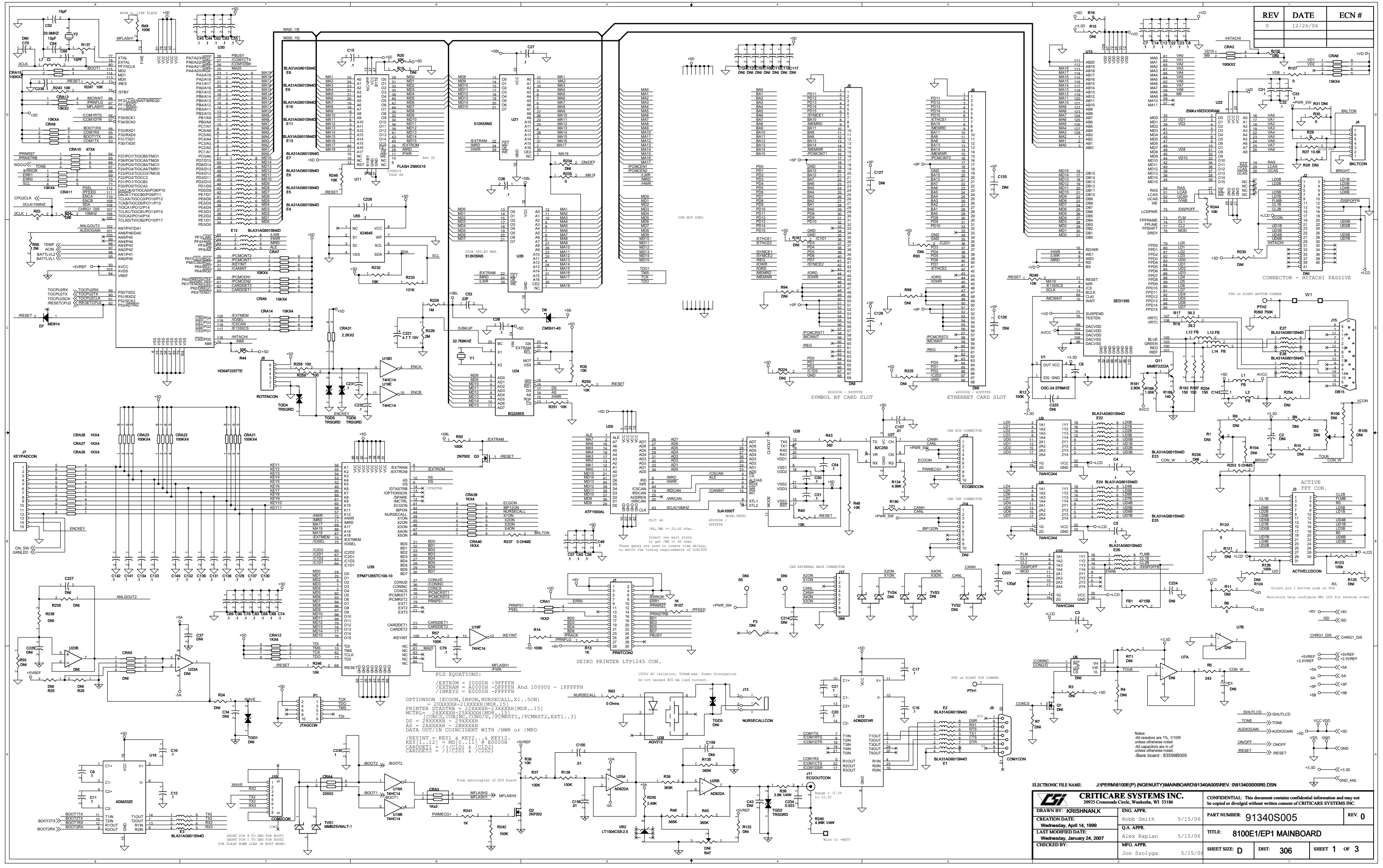

Pin	Signal
1	KEYPADCON
2	KEYPADCON
3	KEYPADCON
4	KEYPADCON
5	KEYPADCON
6	KEYPADCON
7	KEYPADCON
8	KEYPADCON
9	KEYPADCON
10	KEYPADCON
11	KEYPADCON
12	KEYPADCON
13	KEYPADCON
14	KEYPADCON
15	KEYPADCON

Pin	Signal
16	ENCKEY
17	ENCKEY
18	ENCKEY
19	ENCKEY
20	ENCKEY
21	ENCKEY
22	ENCKEY
23	ENCKEY
24	ENCKEY
25	ENCKEY
26	ENCKEY
27	ENCKEY
28	ENCKEY
29	ENCKEY
30	ENCKEY
31	ENCKEY
32	ENCKEY
33	ENCKEY
34	ENCKEY
35	ENCKEY
36	ENCKEY
37	ENCKEY
38	ENCKEY
39	ENCKEY
40	ENCKEY
41	ENCKEY
42	ENCKEY
43	ENCKEY
44	ENCKEY
45	ENCKEY
46	ENCKEY
47	ENCKEY
48	ENCKEY
49	ENCKEY
50	ENCKEY
51	ENCKEY
52	ENCKEY
53	ENCKEY
54	ENCKEY
55	ENCKEY
56	ENCKEY
57	ENCKEY
58	ENCKEY
59	ENCKEY
60	ENCKEY
61	ENCKEY
62	ENCKEY
63	ENCKEY
64	ENCKEY
65	ENCKEY
66	ENCKEY
67	ENCKEY
68	ENCKEY
69	ENCKEY
70	ENCKEY
71	ENCKEY
72	ENCKEY
73	ENCKEY
74	ENCKEY
75	ENCKEY
76	ENCKEY
77	ENCKEY
78	ENCKEY
79	ENCKEY
80	ENCKEY
81	ENCKEY
82	ENCKEY
83	ENCKEY
84	ENCKEY
85	ENCKEY
86	ENCKEY
87	ENCKEY
88	ENCKEY
89	ENCKEY
90	ENCKEY
91	ENCKEY
92	ENCKEY
93	ENCKEY
94	ENCKEY
95	ENCKEY
96	ENCKEY
97	ENCKEY
98	ENCKEY
99	ENCKEY
100	ENCKEY
101	ENCKEY
102	ENCKEY
103	ENCKEY
104	ENCKEY
105	ENCKEY
106	ENCKEY
107	ENCKEY
108	ENCKEY
109	ENCKEY
110	ENCKEY
111	ENCKEY
112	ENCKEY
113	ENCKEY
114	ENCKEY
115	ENCKEY
116	ENCKEY
117	ENCKEY

Pin	Signal
118	ENCKEY
119	ENCKEY
120	ENCKEY
121	ENCKEY
122	ENCKEY
123	ENCKEY
124	ENCKEY
125	ENCKEY
126	ENCKEY
127	ENCKEY
128	ENCKEY
129	ENCKEY
130	ENCKEY
131	ENCKEY
132	ENCKEY
133	ENCKEY
134	ENCKEY
135	ENCKEY
136	ENCKEY
137	ENCKEY
138	ENCKEY
139	ENCKEY
140	ENCKEY
141	ENCKEY
142	ENCKEY
143	ENCKEY
144	ENCKEY
145	ENCKEY
146	ENCKEY
147	ENCKEY
148	ENCKEY
149	ENCKEY
150	ENCKEY
151	ENCKEY
152	ENCKEY
153	ENCKEY
154	ENCKEY
155	ENCKEY
156	ENCKEY
157	ENCKEY
158	ENCKEY
159	ENCKEY
160	ENCKEY
161	ENCKEY
162	ENCKEY
163	ENCKEY
164	ENCKEY
165	ENCKEY
166	ENCKEY
167	ENCKEY
168	ENCKEY
169	ENCKEY
170	ENCKEY
171	ENCKEY
172	ENCKEY
173	ENCKEY
174	ENCKEY
175	ENCKEY
176	ENCKEY
177	ENCKEY
178	ENCKEY
179	ENCKEY
180	ENCKEY
181	ENCKEY
182	ENCKEY
183	ENCKEY
184	ENCKEY
185	ENCKEY
186	ENCKEY
187	ENCKEY
188	ENCKEY
189	ENCKEY
190	ENCKEY
191	ENCKEY
192	ENCKEY
193	ENCKEY
194	ENCKEY
195	ENCKEY
196	ENCKEY
197	ENCKEY
198	ENCKEY
199	ENCKEY
200	ENCKEY

CRITICARE SYSTEMS INC.
 3925 Crossroads Circle, Waukegan, WI 53186

CREATION DATE: Wednesday, April 14, 1999
LAST MODIFIED DATE: Wednesday, January 24, 2007

ENGINEER: Robb Smith
QA APPR: Alex Kaplan
MFG APPR: Jon Szolyva

PART NUMBER: 91340S005
TITLE: 8100E1/EP1 MAINBOARD
SHEET SIZE: D **DIST:** 306 **SHEET 1 OF 3**

REVISIONS: REV 0

NOTES:
 - All resistors are 1%, 1/10W unless otherwise noted.
 - All capacitors are in uF unless otherwise noted.
 - Bare board : 83599B005

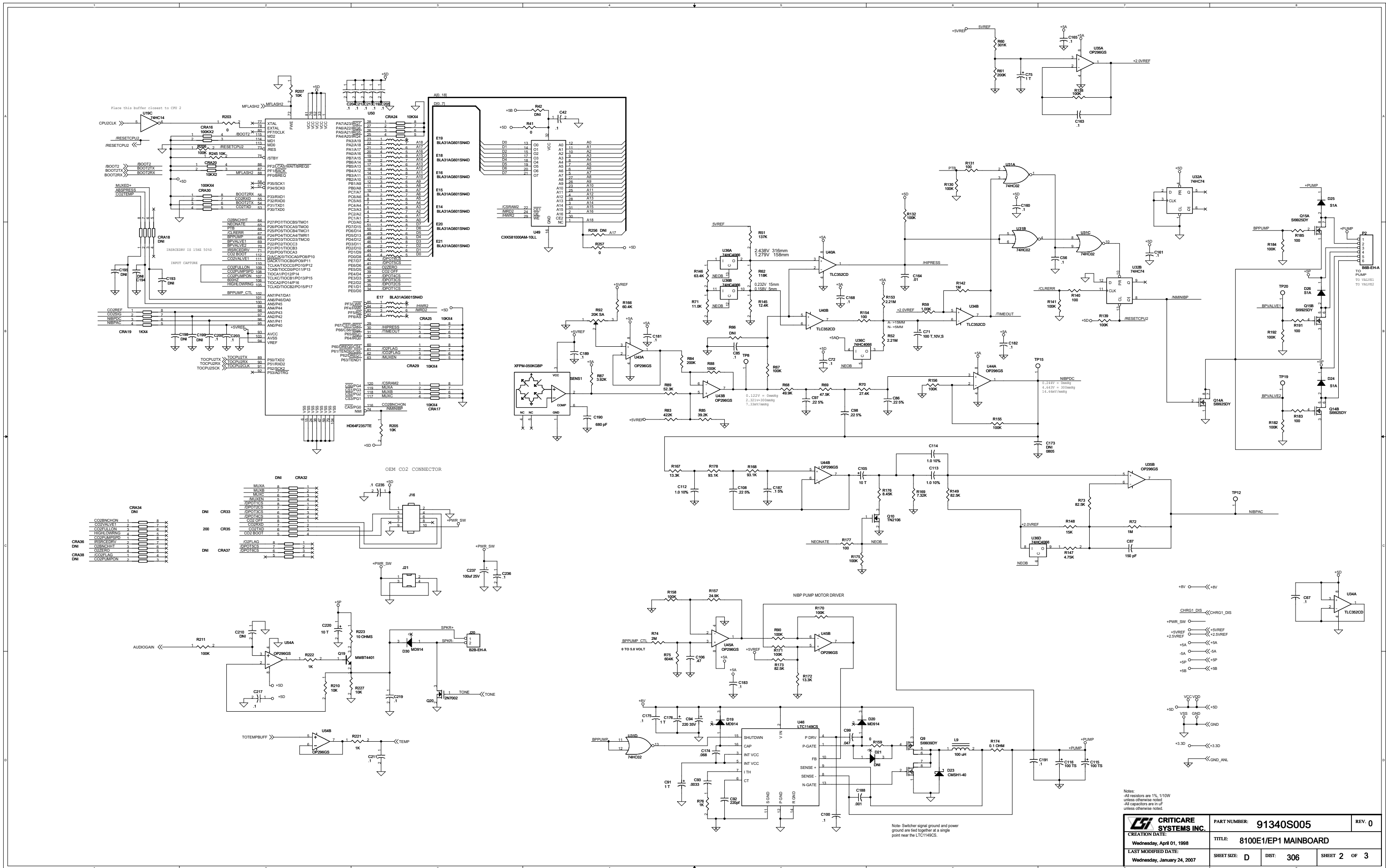

Notes:
 -All resistors are 1%, 1/10W unless otherwise noted.
 -All capacitors are in uF unless otherwise noted.

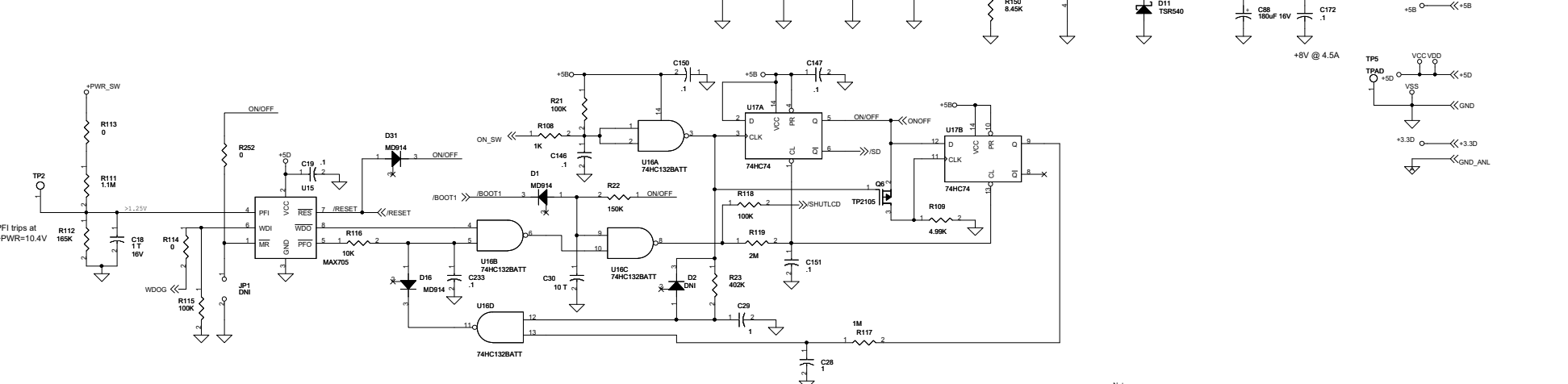
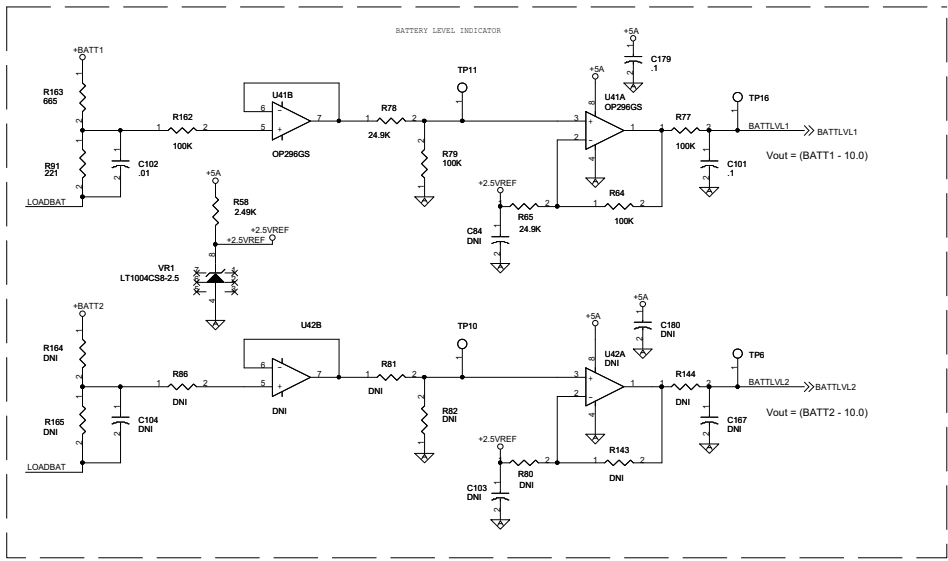
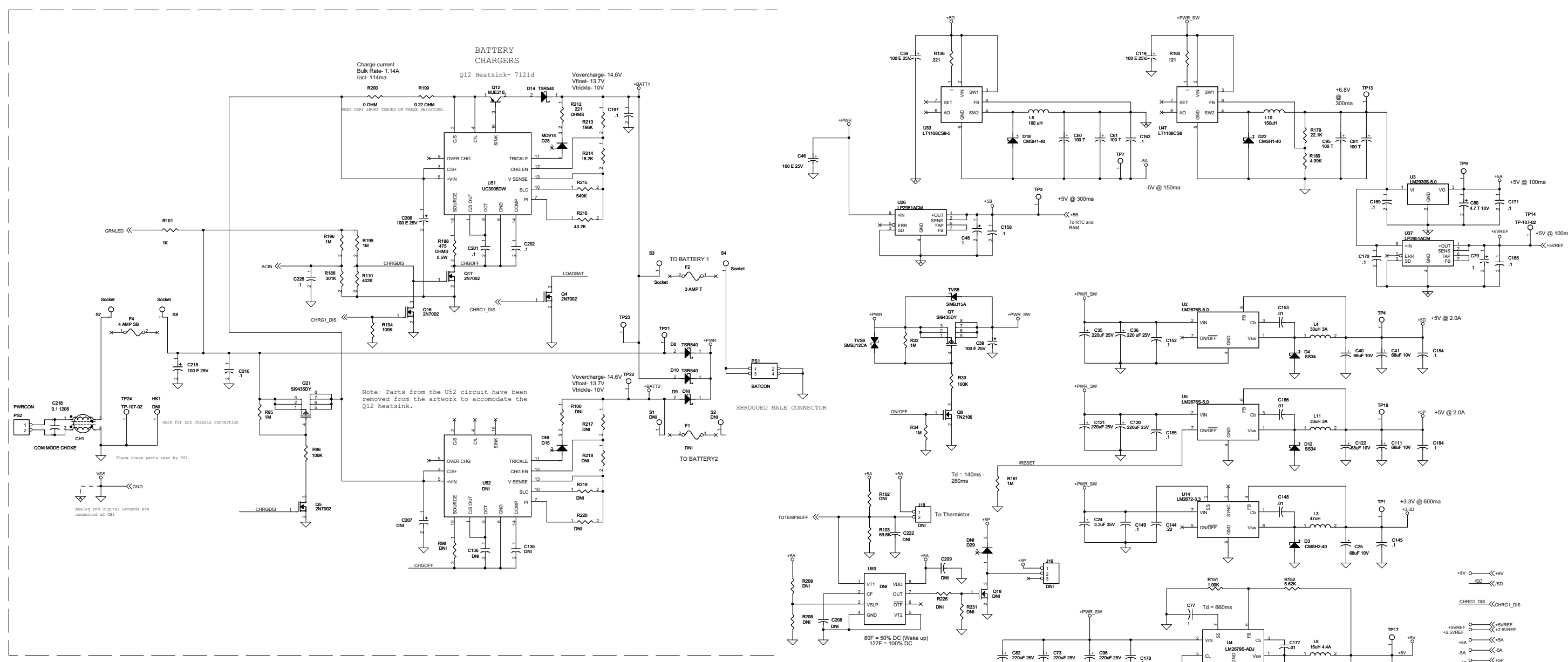

Notes:
 -All resistors are 1%, 1/10W unless otherwise noted.
 -All capacitors are in uF unless otherwise noted.

CRITICARE SYSTEMS INC.	PART NUMBER: 91340S005	REV. 0
CREATION DATE: Monday, May 10, 1998	TITLE: 8100E/EP1 MAINBOARD	
LAST MODIFIED DATE: Wednesday, January 31, 2007	SHEET SIZE: D	DIST: 306
		SHEET 3 OF 3

SEE NOTE #2

SEE NOTE #4 AND DETAIL A

REVISIONS			
REV.	DATE	DESCRIPTION	BY
1	05/15/06	SEE ECN #8845	RWK
2	7/24/06	SEE ECN #8897	DBL
3	11/13/06	SEE ECN #8988	RWK
4	04/01/08	SEE ECN #10202	RWK

SEE NOTE #2

SEE NOTE #3

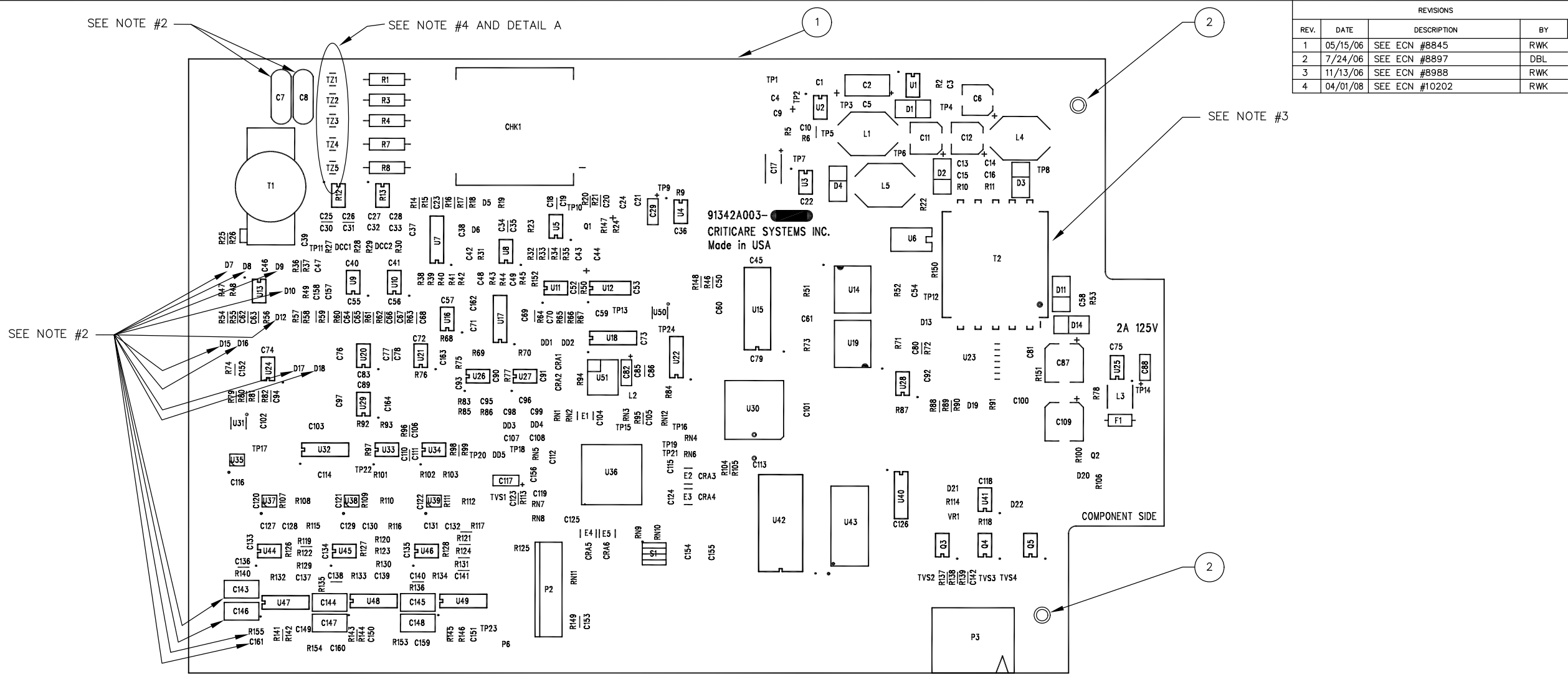

COMPONENT SIDE

NOTES:

- 91342A003 USES BARE BOARD 83602B003.
 - THE FOLLOWING COMPONENTS ARE TO BE ENCAPSULATED IN RTV ADHESIVE (DOW CORNING 3145 PN:MIL-A-46146, CSI PN: 40994B002 OR EQUIVALENT.):
C7, C8, D7, D8, D9, D10, D12, D15, D16, D17, D18 C143, C146, R155 AND C161.
 - ALL TEN (10) LEADS OF T2 ARE TO BE TOTALLY INCAPSULATED WITH RTV ADHESIVE (DOW CORNING 3145 PN: MIL-A-46146, CSI PN 40994B002 OR EQUIVALENT) INSULATING THE TOP, IN-BETWEEN, AND UNDER EACH LEAD TO ENSURE ISOLATION REQUIREMENTS. INSULATING THE TOP, IN-BETWEEN, AND UNDER EACH LEAD TO ENSURE ISOLATION.
 - SOLDER C165-C169 TO TO TOPS OF TZ1- TZ5.
 - FINISHED BOARD SHALL MEET CURRENT IPC-A-600/6012 STANDARDS.
 - FINISHED BOARD THICKNESS SHALL BE .062+/- .010
 - U11 MUST BE A NATIONAL LM358M P/N: (60056B002).
 - BOARD ASSEMBLY HOUSE IS TO PROVIDE SERIALIZATION OF EVERY BOARD.
 - CSI RESERVES THE RIGHT TO INSPECT THIS ITEM AT THE VENDORS FACILITY. VENDORS INSPECTION SYSTEM AND MANUFACTURING PROCESS ARE SUBJECT TO REVIEW/APPROVAL, VERIFICATION, AND ANALYSIS BY AUTHORIZED CSI REPRESENTATIVES. ALL CHANGES IN DESIGN, COMPONENTS, PROCESSES OR FABRICATION MUST BE AUTHORIZED IN WRITING BY CSI PRIOR TO IMPLEMENTATION. ALL DEVIATIONS FROM DRAWINGS, SPECIFICATIONS, OR OTHER REQUIREMENTS MUST BE REPORTED TO CSI FOR APPROVAL PRIOR TO SHIPMENT. ALL RAW MATERIALS USED TO PRODUCE THIS PART SHALL BE TRACEABLE TO AT LEAST A LOT LEVEL. ALL TRACEABILITY AND INSPECTION RECORDS MUST BE IDENTIFIABLE TO THE RAW MATERIALS, PARTS, ASSEMBLIES, OR DEVICES TO WHICH THEY APPLY AND SHALL BE AVAILABLE UPON REQUEST OR AUDIT BY CSI REPRESENTATIVE.
- FIRST ARTICLES MUST BE INSPECTED AND ACCEPTED BY A CSI QUALITY REPRESENTATIVE PRIOR TO A PRODUCTION SHIPMENT, UNLESS OTHERWISE AUTHORIZED BY CSI. THE FIRST ARTICLES MUST BE INSPECTED AND OR TESTED FOR COMPLIANCE TO THE REQUIREMENT OF APPLICABLE ENGINEERING DRAWINGS AND SPECIFICATIONS. FIRST ARTICLES MUST BE SO MARKED AND IDENTIFIED WITH A PART NUMBER. ANY MAJOR TOOLING, PROCESS, OR COMPONENT CHANGE WILL REQUIRE A NEW FIRST ARTICLE EVALUATION. EACH LOT OF PARTS SHALL BE ACCOMPANIED BY A LEGIBLE COPY OF A CERTIFICATE OF COMPLIANCE LISTING THE DRAWING, SPECIFICATION, PROCESS AND APPLICABLE REVISION TO WHICH THE PARTS COMPLY AND BE SIGNED OFF BY THE VENDORS QA REPRESENTATIVE. VENDOR SHALL FURNISH A COPY OF ACTUAL INSPECTION /TEST RESULTS ASSOCIATED WITH EACH SERIALIIZED ITEM. INSPECTION AND TEST PARAMETERS (OPERATIONAL MECHANICAL, ELECTRICAL, ENVIRONMENTAL, ETC) SHALL BE DEFINED BY CSI MANUFACTURING ENGINEERING. EACH ASSEMBLY SHALL BE IDENTIFIED WITH THE CSI PART NUMBER AND REVISION FOR THE ASSEMBLY, AND A UNIQUE SERIAL NUMBER IN HUMAN-READABLE FORMAT. SERIAL NUMBERS SHALL NOT BE DUPLICATED. THE FORMAT FOR THE SERIAL NUMBER SHALL CONTAIN AT LEAST 2 ALPHABETICAL PREFIX CHARACTERS THAT ARE RELEVANT TO THE VENDOR TO DISTINGUISH BETWEEN MULTIPLE VENDORS. THE ASSEMBLY PART NUMBER, REVISION AND SERIAL NUMBER SHALL ALSO BE LABELED ON THE PCB ASSEMBLY IN BARCODE FORMAT USING CODE 39 (PREFERRED) OR CODE 128.

EACH INDIVIDUAL, ASSEMBLED PCB SHALL BE PACKAGED IN CONDUCTIVE, STATIC SHIELDED BAGS OR CONTAINERS AND IDENTIFIED WITH ESD WARNING LABELS.

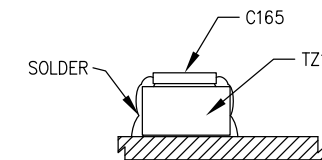

DETAIL A

RELEASED DOCUMENT

VENDOR SHOULD COMPLY WITH THE FOLLOWING CSI QUALITY REQUIREMENTS: Q1, Q2, Q4, Q5, Q6, Q7, Q10, Q11 AND Q16. IN ADDITION THE QUALITY REQUIREMENTS Q9, Q13 AND Q17 APPLY. SEE CSI WEB SITE (www.csiusa.com/pdf/QA_Requirements.pdf) FOR THE DEFINITION OF THE QUALITY REQUIREMENTS

		CHECK BY: DATE: 12/19/05	ENG. APPR.: D.RIECK 02/23/06 Q.A. APPR.: A.KAPLAN 02/23/06
		SCALE: 1:1.5 TOLERANCE UNLESS OTHERWISE SPECIFIED: XX: +/- .020 XXX: +/- .005 ANGLES: +/- 1 DEGREE	DO NOT SCALE PRINT MFG. APPR.: J.SZOLYGA 02/23/06 CONFIDENTIAL: THIS DOCUMENT CONTAINS CONFIDENTIAL INFORMATION AND MAY NOT BE COPIED OR DIVULGED WITHOUT WRITTEN CONSENT OF CRITICARE SYSTEMS, INC.
TITLE: ASSEMBLY 8100 ANALOG BOARD		PART NO.: 91342A003	REV.: 4
DIST:		SHEET 1 OF 2	

REVISIONS			
REV.	DATE	DESCRIPTION	BY
		SEE SHEET 1	

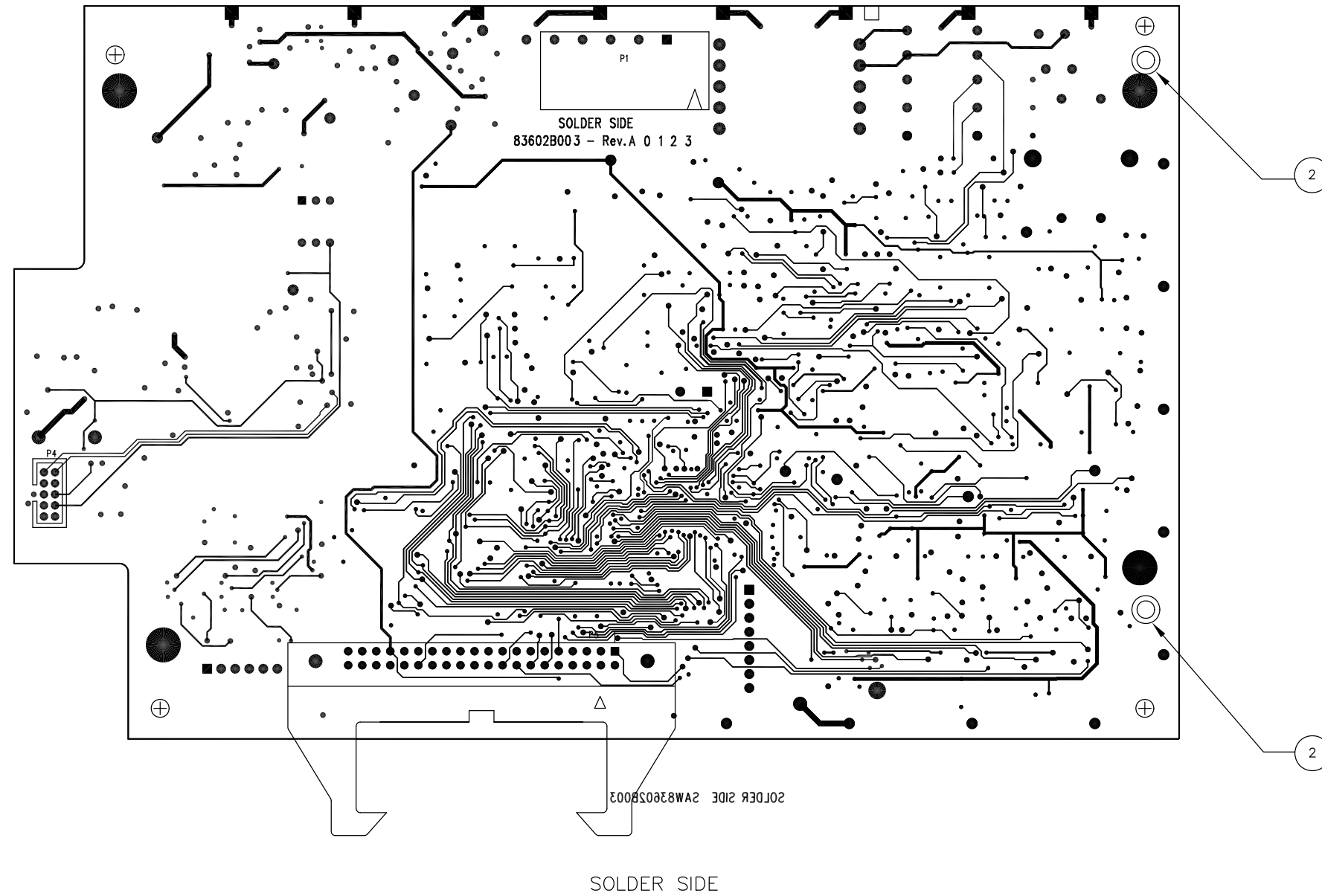

NOTE: TRIM EXCESS LEADS ON TP1, TP2, TP3, TP4, TP5 AND TP8.

VENDOR SHOULD COMPLY WITH THE FOLLOWING CSI QUALITY REQUIREMENTS: Q1, Q2, Q4, Q5, Q6, Q7, Q10, Q11 AND Q16. IN ADDITION THE QUALITY REQUIREMENTS Q9, Q13 AND Q17 APPLY. SEE CSI WEB SITE (www.csiusa.com/pdf/QA_Requirements.pdf) FOR THE DEFINITION OF THE QUALITY REQUIREMENTS



DRAWN BY: RWK	CHECK BY:	ENG. APPR.:
DATE: 12/19/05	RELEASE DATE:	Q.A. APPR.:
SCALE: 1:1.5	DO NOT SCALE PRINT	MFG. APPR.:
TOLERANCE UNLESS OTHERWISE SPECIFIED: XX: +/- .020 XXX: +/- .005 ANGLES: +/- 1 DEGREE	CONFIDENTIAL: THIS DOCUMENT CONTAINS CONFIDENTIAL INFORMATION AND MAY NOT BE COPIED OR DIVULGED WITHOUT WRITTEN CONSENT OF CRITICARE SYSTEMS, INC.	
TITLE: ASSEMBLY 8100 ANALOG BOARD	PART NO.: 91342A003	REV.: 4
DIST:	SHEET 2	OF 2

REV	DATE	ECN #
1	6/20/06	8897

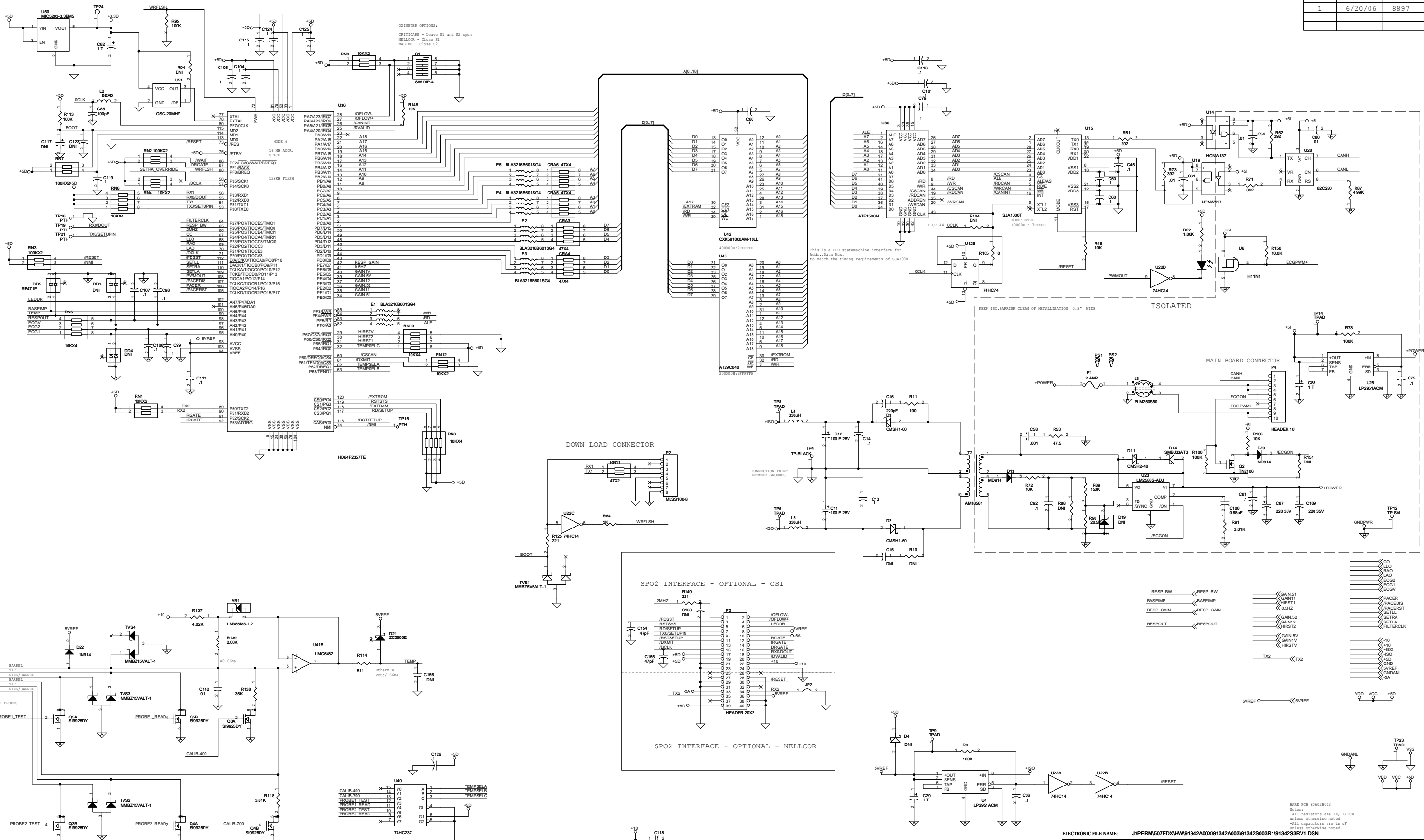

ELECTRONIC FILE NAME: J:\PERM507ED\KHM\81342A00X\81342A003\81342S003R1\81342S3RV1.DSN		CONFIDENTIAL: This document contains confidential information and may not be copied or divulged without written consent of CRITICARE SYSTEMS INC.	
CSI CRITICARE SYSTEMS INC. 20925 Crossroads Circle, Waukesha, WI 53186		PART NUMBER: 91342S003	
DRAWN BY: DJR	ENG. APPR: David Rieck 5/09/06	REV. 1	
CREATION DATE:	Q.A. APPR: Alex Kaplan 5/10/06	TITLE: 8100 ECG/ANALOG BOARD	
LAST MODIFIED DATE: Tuesday, June 20, 2006	MFG. APPR: Keith Hawver 5/10/06	SHEET SIZE: D	
CHECKED BY:		DIST: 306	SHEET 1 OF 3

NOTE: PCB #36028003
Notes:
-All resistors are 1%, 1/10W
-All capacitors are in uF
-unless otherwise noted.

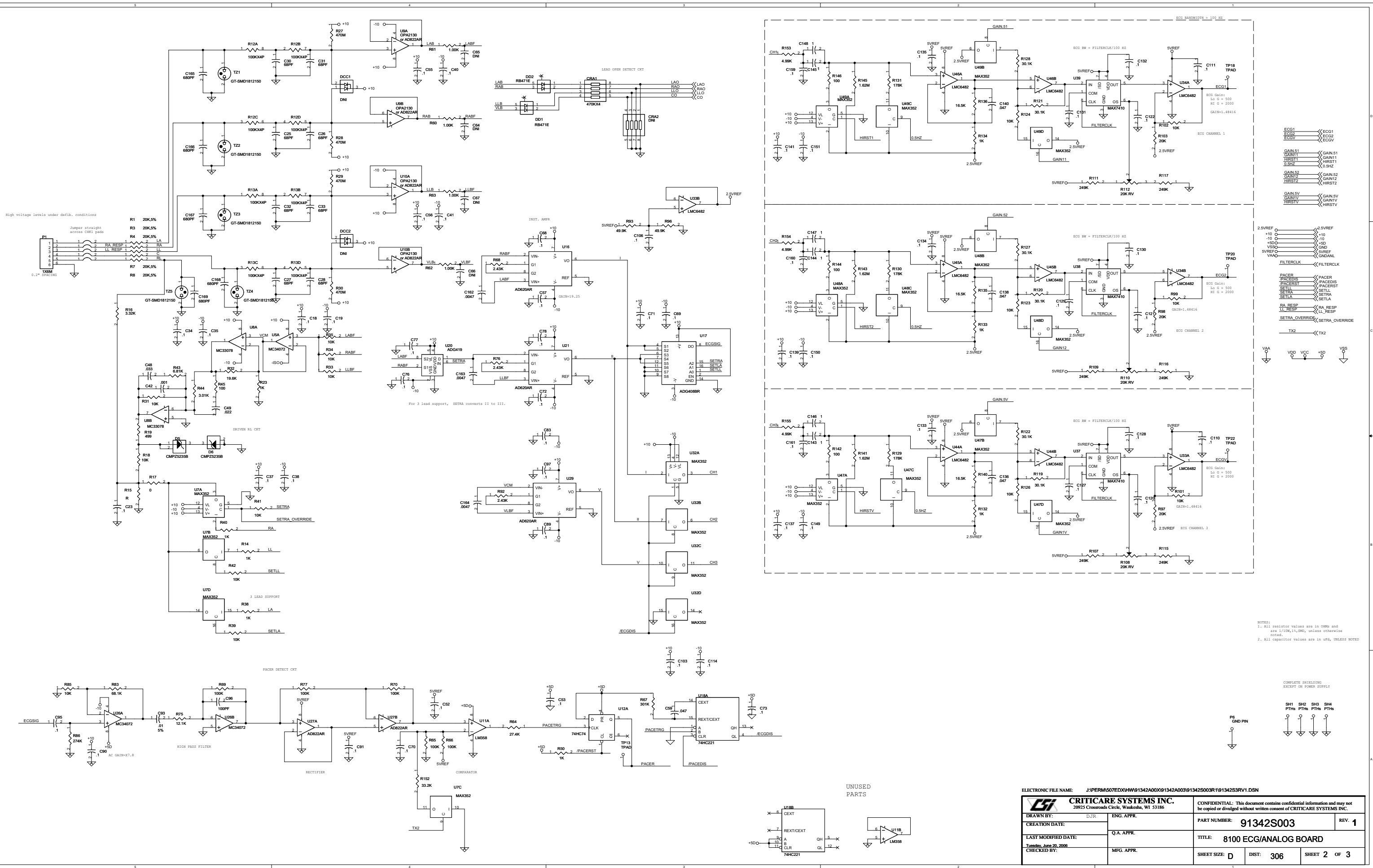

High voltage levels under defib. conditions
 Jumper straight across C83 leads
 18XMM
 0.2" SPACING

For 3 lead support, SETRA converts II to III.

- ECG1 <-> ECG1
- ECG2 <-> ECG2
- ECG3 <-> ECG3
- GAIN1 <-> GAIN1
- HIRST1 <-> HIRST1
- 0.5HZ <-> 0.5HZ
- GAIN2 <-> GAIN2
- GAIN3 <-> GAIN3
- HIRST2 <-> HIRST2
- GAIN5V <-> GAIN5V
- GAIN1V <-> GAIN1V
- HIRSTV <-> HIRSTV
- 2.5VREF <-> 2.5VREF
- +10 <-> +10
- 10 <-> -10
- +5D <-> +5D
- V550 <-> V550
- SVREF <-> SVREF
- V40 <-> V40
- FILTERCLK <-> FILTERCLK
- PACER <-> PACER
- PACERST <-> PACERST
- SETLA <-> SETLA
- SETLA <-> SETLA
- RA RESP <-> RA RESP
- LL RESP <-> LL RESP
- SETLA_OVERRIDE <-> SETLA_OVERRIDE
- TX2 <-> TX2
- VAA <-> VAA
- VDD <-> VDD
- VCC <-> VCC
- +5D <-> +5D
- VSS <-> VSS

NOTES:
 1. All resistor values are in Ohms and are 1/10W, 1%, unless otherwise noted.
 2. All capacitor values are in uFd, UNLESS NOTED

COMPLETE SHIELDING EXCEPT ON POWER SUPPLY
 SH1 SH2 SH3 SH4
 PTHs PTHs PTHs PTHs
 GND PIN

ELECTRONIC FILE NAME: J:\PERM\507ED\XHW\91342A00\91342A00\91342S00\3R191342S3RV1.DSN			
CRITICARE SYSTEMS INC. 20925 Crossroads Circle, Waukesha, WI 53186		CONFIDENTIAL: This document contains confidential information and may not be copied or divulged without written consent of CRITICARE SYSTEMS INC.	
DRAWN BY: DJR	ENG. APPR.	PART NUMBER: 91342S003	REV. 1
CREATION DATE:	Q.A. APPR.	TITLE: 8100 ECG/ANALOG BOARD	
LAST MODIFIED DATE: Tuesday, June 20, 2006	MFG. APPR.	SHEET SIZE: D	DIST: 306
CHECKED BY:		SHEET 2	OF 3

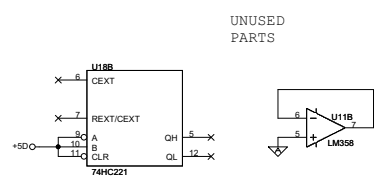

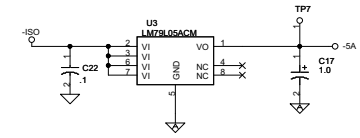
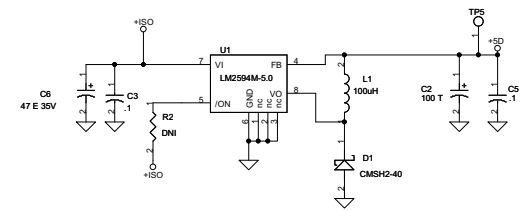
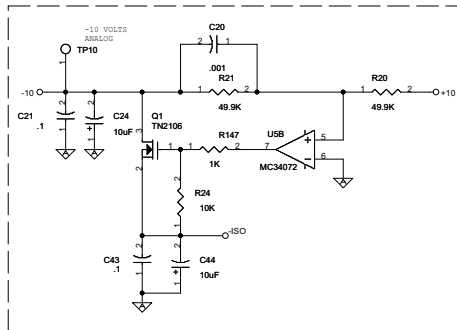
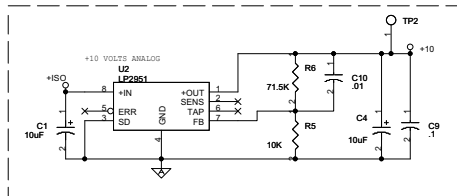

Respiration

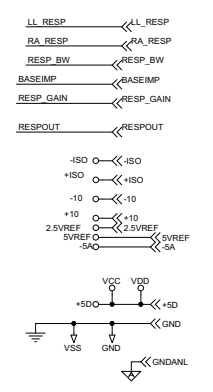
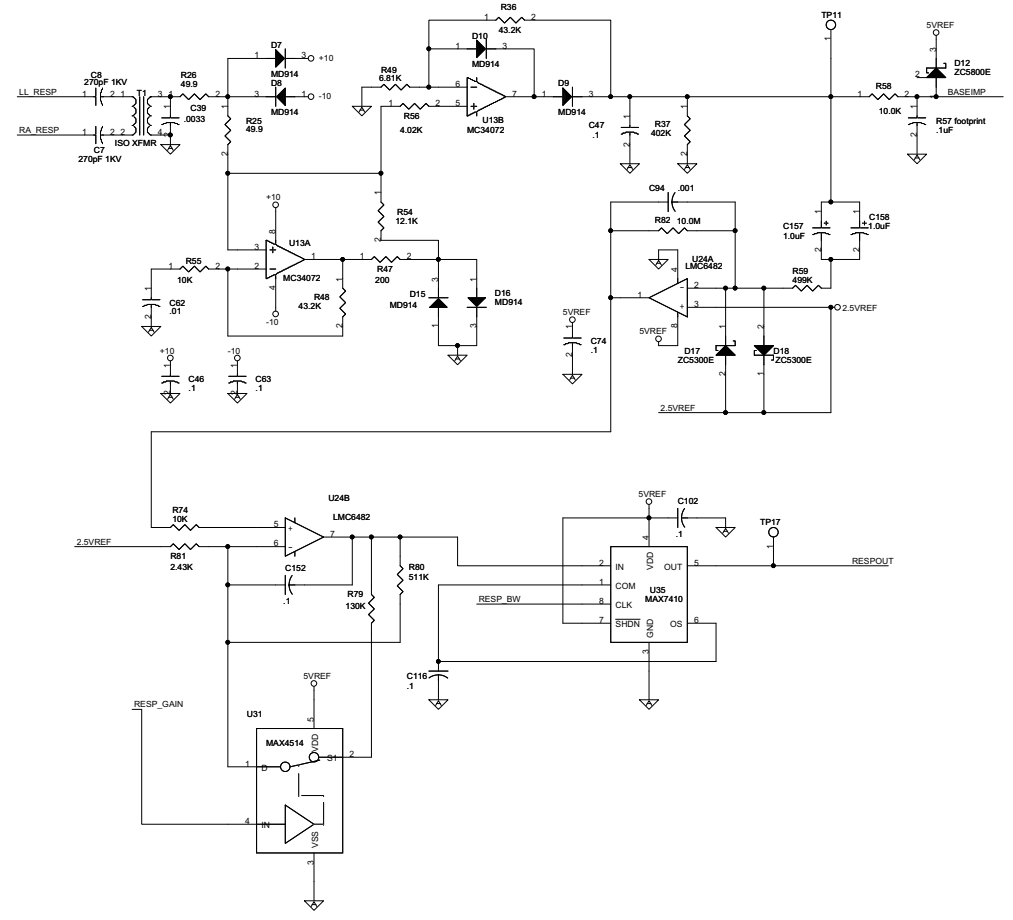

ELECTRONIC FILE NAME: J:\PERM507ED\HW\91342A00X\91342A009\91342S003R1\91342S3RV1.DSN

CRITICARE SYSTEMS INC. 20925 Crossroads Circle, Waukesha, WI 53186		CONFIDENTIAL: This document contains confidential information and may not be copied or divulged without written consent of CRITICARE SYSTEMS INC.	
DRAWN BY: DJR CREATION DATE:	ENG. APPR.:	PART NUMBER: 91342S003	REV. 1
LAST MODIFIED DATE: Tuesday, June 20, 2006	Q.A. APPR.:	TITLE: 8100 ECG/ANALOG BOARD	
CHECKED BY:	MFG. APPR.:	SHEET SIZE: D	DIST: 306
		SHEET 3 OF 3	

REVISIONS			
REV.	DATE	DESCRIPTION	BY
1	7/6/00	SEE ECN #6382	DBL
2	11/30/00	SEE ECN #6601	AEL
3	1/22/01	SEE ECN #6732	AEL
4	10/21/02	SEE ECN #7417	DBL
5	04/16/03	SEE ECN #7608	RWK
6	05/15/06	SEE ECN #8845	RWK
7	11/06/07	SEE ECN #10108	RWK
8	05/20/08	SEE ECN #10237	RWK

AFTER SOLDERING, SECURE TO PCB WITH CSI P/N 40046B001 OR EQUIV. AS SHOWN. $\triangle 1$

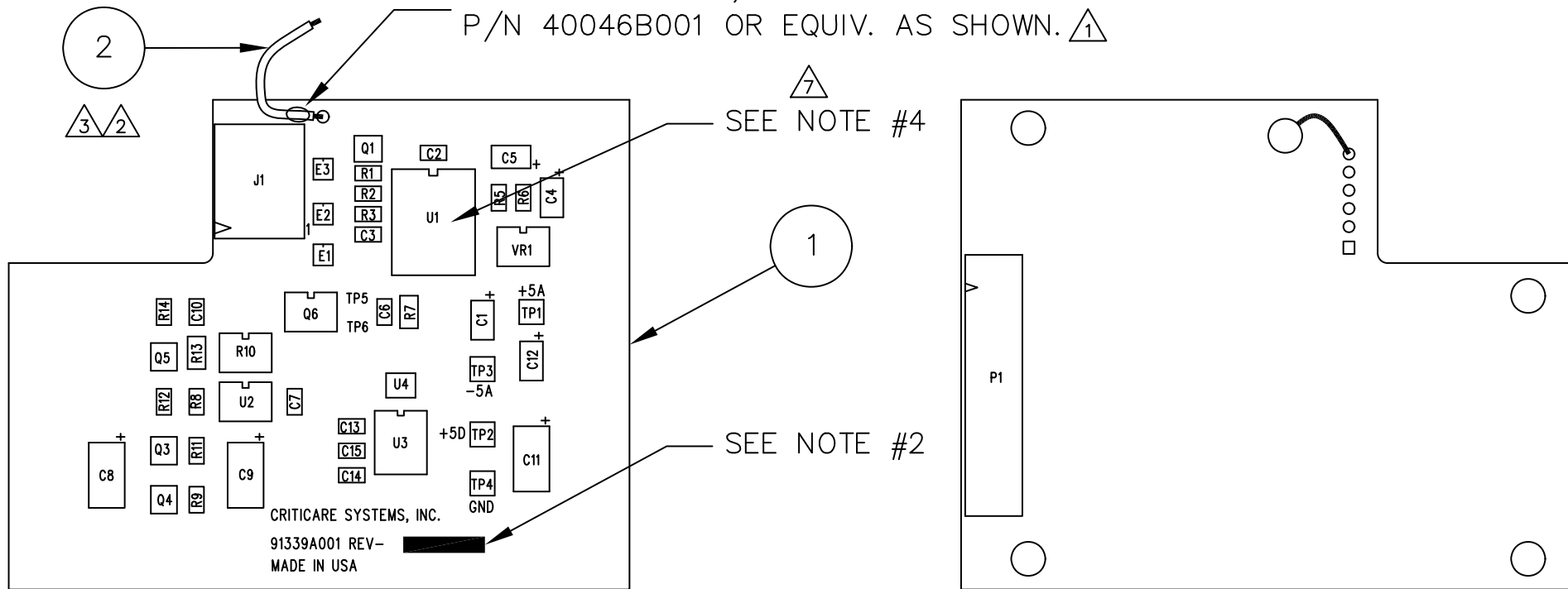

COMPONENT SIDE

SOLDER SIDE

NOTES:

- 1.) ASSEMBLY 91339A001 USES BARE BOARD 83603B001.
- 2.) WRITE OR LABEL BOARD WITH CURRENT BUILD REVISION.
- 3.) CSI RESERVES THE RIGHT TO INSPECT THIS ITEM AT THE VENDORS FACILITY. VENDORS INSPECTION SYSTEM AND MANUFACTURING PROCESS ARE SUBJECT TO REVIEW/APPROVAL, VERIFICATION AND ANALYSIS BY AUTHORIZED CSI REPRESENTATIVES. ALL CHANGES IN DESIGN, COMPONENTS, PROCESSES OR FABRICATION MUST BE AUTHORIZED IN WRITING BY CSI PRIOR TO IMPLEMENTATION. ALL DEVIATIONS FROM DRAWINGS, SPECIFICATIONS, OR OTHER REQUIREMENTS MUST BE REPORTED TO CSI FOR APPROVAL PRIOR TO SHIPMENT. ALL RAW MATERIALS USED TO PRODUCE THIS PART SHALL BE TRACEABLE TO AT LEAST A LOT LEVEL. ALL TRACEABILITY AND INSPECTION RECORDS MUST BE IDENTIFIABLE TO THE RAW MATERIALS, PARTS, ASSEMBLIES, OR DEVICES TO WHICH THEY APPLY AND SHALL BE AVAILABLE UPON REQUEST OR AUDIT BY CSI REPRESENTATIVE.

FIRST ARTICLES MUST BE INSPECTED AND ACCEPTED BY A CSI QUALITY REPRESENTATIVE PRIOR TO A PRODUCTION SHIPMENT, UNLESS OTHERWISE AUTHORIZED BY CSI. THE FIRST ARTICLES MUST BE INSPECTED AND OR TESTED FOR COMPLIANCE TO THE REQUIREMENT OF APPLICABLE ENGINEERING DRAWINGS AND SPECIFICATIONS. FIRST ARTICLES MUST BE SO MARKED AND IDENTIFIED WITH A PART NUMBER. ANY MAJOR TOOLING, PROCESS, OR COMPONENT CHANGE WILL REQUIRE A NEW FIRST ARTICLE EVALUATION.

EACH LOT OF PARTS SHALL BE ACCOMPANIED BY A LEGIBLE COPY OF A CERTIFICATE OF COMPLIANCE LISTING THE DRAWING, SPECIFICATION, PROCESS AND APPLICABLE REVISION TO WHICH THE PARTS COMPLY AND BE SIGNED OFF BY THE VENDORS QA REPRESENTATIVE.

VENDOR SHALL FURNISH A COPY OF ACTUAL INSPECTION/TEST RESULTS ASSOCIATED WITH EACH SERIALIZED ITEM. INSPECTION AND TEST PARAMETERS (OPERATIONAL, MECHANICAL, ELECTRICAL, ENVIRONMENTAL, ETC) SHALL BE DEFINED BY CSI MANUFACTURING ENGINEERING.

EACH ASSEMBLY SHALL BE IDENTIFIED WITH THE CSI PART NUMBER AND REVISION FOR THE ASSEMBLY, AND A UNIQUE SERIAL NUMBER IN HUMAN-READABLE FORMAT. SERIAL NUMBERS SHALL NOT BE DUPLICATED. THE FORMAT FOR THE SERIAL NUMBER SHALL CONTAIN AT LEAST 2 ALPHABETICAL PREFIX CHARACTERS THAT ARE RELEVANT TO THE VENDOR TO DISTINGUISH BETWEEN MULTIPLE VENDORS. THE ASSEMBLY PART NUMBER, REVISION AND SERIAL NUMBER SHALL ALSO BE LABELED ON THE PCB ASSEMBLY IN BARCODE FORMAT USING CODE 39 (PREFERRED) OR CODE 128.

EACH INDIVIDUAL, ASSEMBLED PCB SHALL BE PACKAGED IN CONDUCTIVE, STATIC SHIELDING BAGS OR CONTAINERS AND IDENTIFIED WITH ESD WARNING LABELS.
- 4.) IF CSI P/N 68005B001 IS NOT AVAILABLE REFER TO INSTRUCTION SHEET CSI P/N 91339A1-ALT FOR ALTERNATE BUILD. IF ALTERNATE BUILD IS IMPLEMENTED, MARK THE REVISION AS REV. 7A ON THE PCB AND ALSO NOTE THIS ON THE CERTIFICATE OF COMPLIANCE.



VENDOR SHOULD COMPLY WITH THE FOLLOWING CSI QUALITY REQUIREMENTS: Q1, Q2, Q4, Q5, Q6, Q7, Q10, Q11 AND Q16. IN ADDITION THE QUALITY REQUIREMENTS Q9, Q13 AND Q17 APPLY. SEE CSI WEB SITE (www.csiusa.com/pdf/QA_Requirements.pdf) FOR THE DEFINITION OF THE QUALITY REQUIREMENTS

CRITICARE SYSTEMS, INC.		
DRAWN BY: DBL	CHECK BY:	ENG. APPR.: D. RIECK 6/7/00
DATE: 8/23/99	RELEASE DATE:	Q.A. APPR.: A. KAPLAN 6/8/00
SCALE: 1:1	DO NOT SCALE PRINT	MFG. APPR.: K. SCHMITZ 6/7/00
TOLERANCE UNLESS OTHERWISE SPECIFIED: XX: +/- .020 XXX: +/- .005 ANGLES: +/- 1 DEGREE		CONFIDENTIAL: THIS DOCUMENT CONTAINS CONFIDENTIAL INFORMATION AND MAY NOT BE COPIED OR DIVULGED WITHOUT WRITTEN CONSENT OF CRITICARE SYSTEMS, INC.
TITLE: ASSEMBLY PCB SPO2 BOARD		PART NO.: 91339A001 REV.: 8
DIST: 302		SHEET 1 OF 1

The following resistor values are used when 91418A001 is used for U1:

- R1: 39.2K
- R2: 10K
- R3: 130K

REV	DATE	ECN #
1	7/10/00	6419
2	10/25/07	10108

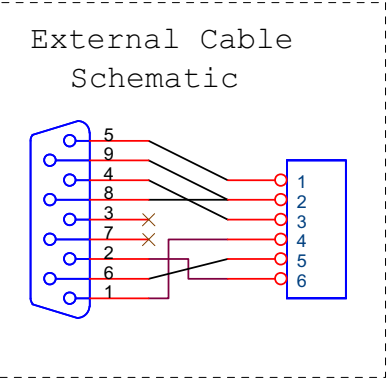
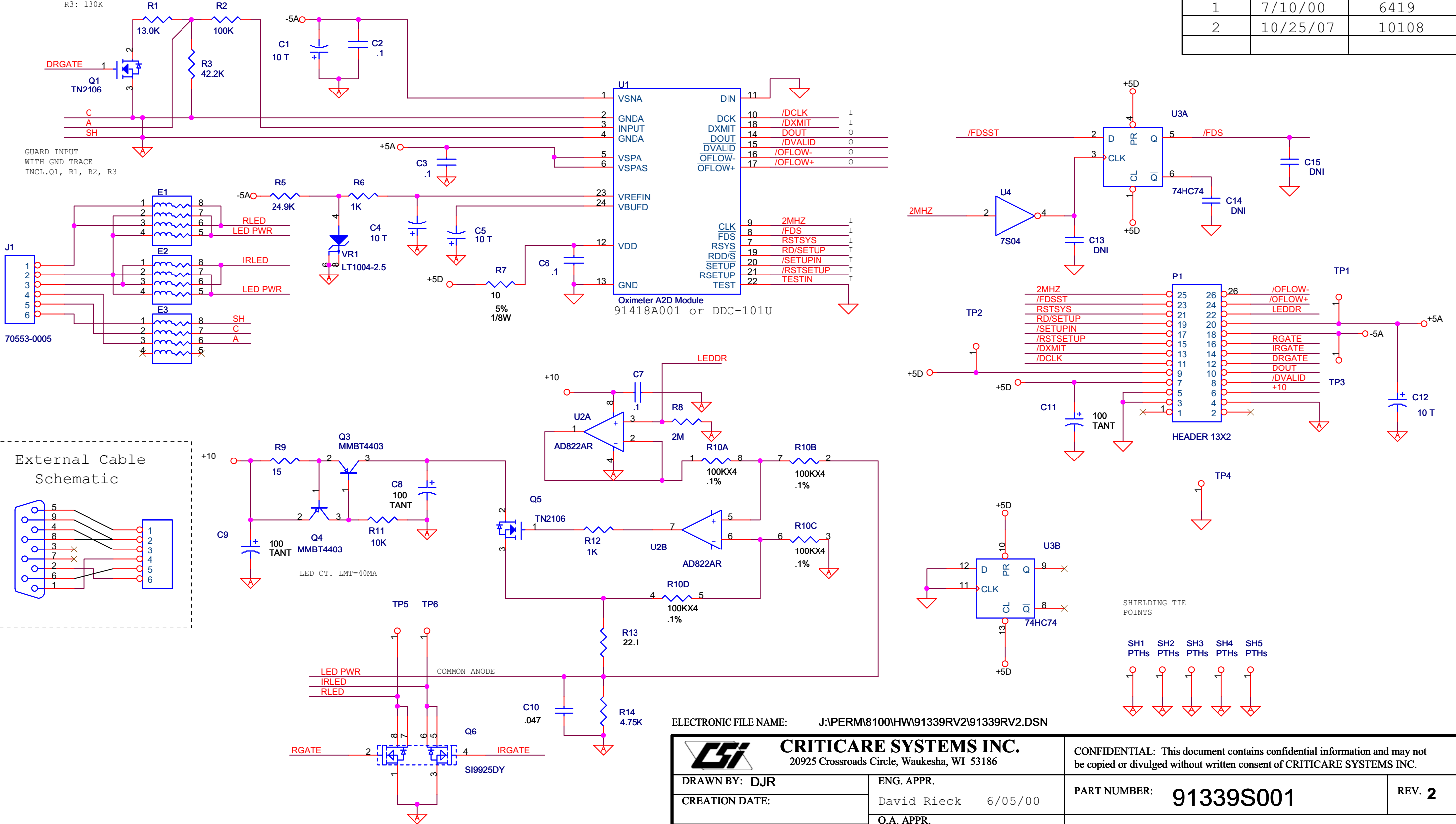

ELECTRONIC FILE NAME: J:\PERM8100\HW\91339RV2\91339RV2.DSN

<p>20925 Crossroads Circle, Waukesha, WI 53186</p>		<p>CONFIDENTIAL: This document contains confidential information and may not be copied or divulged without written consent of CRITICARE SYSTEMS INC.</p>	
<p>DRAWN BY: DJR</p> <p>CREATION DATE:</p> <p>LAST MODIFIED DATE: Thursday, November 01, 2007</p> <p>CHECKED BY:</p>	<p>ENG. APPR.</p> <p>David Rieck 6/05/00</p> <p>Q.A. APPR.</p> <p>Alex Kaplan 6/08/00</p> <p>MFG. APPR.</p> <p>Ken Schmitz 6/08/00</p>	<p>PART NUMBER: 91339S001</p> <p>TITLE: Circuit Schematic 8100/9100 SpO2</p> <p>SHEET SIZE: B</p>	<p>REV. 2</p> <p>DIST: 306</p> <p>SHEET 1 OF 1</p>



BARE PCB: 83603B001 REV 0.