

TEC-7511K TEC-7511A
TEC-7521K TEC-7521A
TEC-7531K TEC-7531A

TEC-7511R TEC-7511C
TEC-7521R TEC-7521C
TEC-7531R TEC-7531C

TEC-7511E
TEC-7521E
TEC-7531E

TEC-7511F
TEC-7521F
TEC-7531F

TEC-7511G
TEC-7521G
TEC-7531G

PORTABLE DEFIBRILLATOR

TEC-7500

CONTENTS

Conventions	0.1
◆ Warnings, Cautions and Notes	0.1
◆ Symbols	0.2
Section 1 General	1.C1
1-1 Introduction	1.1
1-2 Service Policy	1.2
1-3 Specifications	1.3
1-4 Composition	1.9
1-4-1 TEC-7511A/C/E/F/G/K/R Defibrillator	1.9
1-4-2 TEC-7521A/C/E/F/G/K/R Defibrillator	1.11
1-4-3 TEC-7531A/C/E/F/G/K/R Defibrillator	1.13
1-5 Panels and Controls	1.15
1-6 Board/unit Location	1.20
1-7 Overall Block Diagram	1.21
1-8 Connection Diagram	1.22
1-9 Storage and Transport	1.23
Section 2 Error Codes, Error Messages and Troubleshooting	2.C1
2-1 Error Codes	2.2
2-1-1 HV Unit Related Error Codes	2.2
2-1-2 Pacing Related Error Codes	2.3
2-1-3 Switch and Key Related Error Codes	2.4
2-1-4 ROM and RAM Related Error Codes	2.6
2-2 Screen Messages	2.8
2-3 Troubleshooting	2.11
2-3-1 General Problems	2.11
2-3-2 Recording Problems	2.12
2-3-3 Monitoring Problems	2.12
2-3-4 Defibrillating Problems	2.13
2-3-5 Pacing Problems (For TEC-7351 only)	2.14
2-3-6 Option Related Problems	2.14
Section 3 Board/unit Description	3.C1
3-1 CPU Board	3.2
3-2 Mother Board	3.5
3-3 Switch and LED Board	3.9
3-4 Test Load Board	3.10

3-5	Pacing Switch Board (For TEC-7531 Only)	3.11
3-6	Pacing Output Board (For TEC-7531 Only)	3.12
3-7	HV Relay Unit	3.14
3-8	External Paddles	3.16
3-9	Recorder Unit	3.17
3-10	ZR-I/F Unit	3.18
3-11	ZB I/F Unit	3.19

Section 4 Disassembly and Assembly 4.C1

4-1	Before You Begin	4.1
4-2	Replacing the Battery	4.2
4-3	Removing the Top Case	4.3
4-4	Removing the Front Unit Assy	4.5
4-5	Replacing the Power Unit (AC/DC Unit)	4.7
4-6	Replacing the CPU Board	4.8
4-7	Replacing the Mother Board	4.9
4-8	Replacing the Paddles	4.10
4-9	Replacing the Paddles' Release Knob	4.11
4-10	Replacing the Recorder Unit	4.12
4-11	Replacing the CRT Unit	4.13
4-12	Cables Connections of the High Voltage Unit	4.15
4-13	Maintenance Schedule	4.16

Section 5 Checks, Settings and Adjustments 5.C1

5-1	Calling Up the System Maintenance Screen	5.1
5-2	Calling Up the System Maintenance Item	5.3
5-3	System Maintenance (A) Screen	5.4
5-4	System Maintenance (B) Screen	5.5
5-4-1	System Maintenance (B-1) Test Key Screen	5.6
5-4-2	System Maintenance (B-2) Test Lamp Screen	5.8
5-4-3	System Maintenance (B-3) Test CRT Screen	5.9
5-4-4	System Maintenance (B-4) CAL Wave Display Screen	5.10
5-5	System Maintenance (C) Menu Screen	5.12
5-5-1	System Maintenance (C-1) Adjust ECG Gain Screen	5.13
5-5-2	System Maintenance (C-2) Adjust Battery Voltage Screen	5.16
5-5-3	System Maintenance (C-3) Adjust HV Screen	5.18
5-5-4	System Maintenance (C-4) System Check Screen	5.23
5-5-5	Set Function: System Maintenance (C) Screen	5.24
5-5-6	Tele: System Maintenance (C) Screen	5.25
5-5-7	Alarm Off Message: System Maintenance (C) Screen	5.26
5-5-8	Language: System Maintenance (C) Screen	5.27
5-5-9	Charge Times Clear: System Maintenance (C) Screen	5.28
5-5-10	SRAM Clear: System Maintenance (C) Screen	5.29
5-5-11	EEPROM Save: System Maintenance (C) Screen	5.30

5-5-12	Debug (RS232C): System Maintenance (C) Screen	5.31
5-6	System Maintenance (D) Menu Screen	5.32
5-6-1	System Maintenance (D-1) A/D Value Screen	5.34

Section 6 Replaceable Parts List 6.C1

6-1	Main Unit Parts	6.2
6-2	ND-752V External Paddle Parts	6.8
6-3	QI-751V Transmitter Interface Unit Parts	6.10
6-4	ZR-751V Telemetry Receiver Parts	6.12
6-5	ZA-003P Antenna and Antenna Mount Parts	6.14
6-6	KD-001A Cart Parts	6.16

Section 7 Connector Pin Assignment 7.C1

7-1	UR-0119 CPU Board	7.1
7-1-1	CN1101	7.1
7-1-2	CN1102	7.3
7-1-3	CN1103	7.4
7-1-4	CN1104	7.5
7-1-5	CN1105	7.5
7-2	UR-0120 Mother Board	7.6
7-2-1	CN020	7.6
7-2-2	CN2032	7.6
7-2-3	CN2051	7.6
7-2-4	CN2071	7.6
7-2-5	CN2141	7.7
7-2-6	CN2142	7.9
7-2-7	CN2143	7.9
7-2-8	CN2144	7.9
7-2-9	CN2151	7.10
7-2-10	CN2152	7.10
7-2-11	CN2153A	7.11
7-2-12	CN2153B	7.11
7-2-13	CN2154A	7.12
7-2-14	CN2154B	7.12
7-2-15	CN2155	7.13
7-2-16	CN2222	7.13
7-2-17	CN2223	7.14
7-2-18	CN2224	7.14
7-2-19	CN2225	7.14
7-2-20	CN2226	7.14
7-3	UR-0121 HV Drive Board	7.15
7-3-1	CN501	7.15
7-3-2	CN511	7.15
7-3-3	CN551	7.16
7-4	UR-0146 Switch & LED Board	7.17
7-4-1	CN101	7.17
7-5	UR-0147 Test Load Board	7.18

7-5-1	CN101	7.18
7-5-2	CN102	7.18
7-5-3	CN103	7.18
7-6	UR-0148 Pacing Switch Board	7.19
7-6-1	CN101	7.19
7-7	UR-0149 Pacing Output Board	7.20
7-7-1	CN101	7.20
7-8	WS-751V Recorder Unit	7.21
7-8-1	CN018	7.21
7-8-2	CN019	7.21
7-8-3	CN060	7.22

Conventions Used in This Manual and Instrument

◆ Warnings, Cautions and Notes

Warning, cautions and notes are used in this manual to alert the reader to specific information.

WARNING

A warning alerts the user to the possible injury or death associated with the use or misuse of the instrument.

CAUTION

A caution alerts the user to possible problems with the instrument associated with its use or misuse, such as instrument malfunction, instrument failure, damage to instrument, or damage to other property.





NOTE

A note provides specific information, in the form of recommendations, prerequisites, alternative methods or supplemental information.

CONVENTIONS USED IN THIS MANUAL AND INSTRUMENT

◆ Symbols

The symbols shown below are found inside the instrument. Refer to the operator's manual for other symbols found on the surface of instrument.

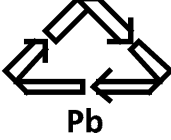
 Protective ground terminal	 Functional ground terminal
 Fuse	 Attention, consult operator's manual
 High voltage	 Recycle mark (for battery)

Section 1 GENERAL

1-1	Introduction	1.1
1-2	Service Policy	1.2
1-3	Specifications	1.3
1-4	Composition	1.9
1-4-1	TEC-7511A/C/E/F/G/K/R Defibrillator	1.9
1-4-2	TEC-7521A/C/E/F/G/K/R Defibrillator	1.11
1-4-3	TEC-7531A/C/E/F/G/K/R Defibrillator	1.13
1-5	Panels and Controls	1.15
1-6	Board/unit Location	1.20
1-7	Overall Block Diagram	1.21
1-8	Connection Diagram	1.22
1-9	Storage and Transport	1.23

1-1 Introduction

This service manual is designed to provide useful information to qualified service personnel to understand, troubleshoot, service, maintain and repair this TEC-7500 Series Defibrillator (referred to as “the instrument” in this service manual). All replaceable parts or units of this instrument and its optional units are clearly listed with exploded illustration to help you locate the parts quickly.

There are a few models in the TEC-7500 series defibrillators; each having slightly different functionality. This service manual is written, in general, for all the models in this series. Therefore, depending on the function, some description apply only to certain model that has the described function. The functionality difference is described in the table below.

		TEC-7511	TEC-7521	TEC-7531
Paddle	External	Yes	Yes	Yes
	Internal	NA	Option	Option
	Disposable pads	NA	Option	Yes
Non invasive pacing		NA	NA	Yes
Telemetry		Option	Option	Option
TTR Measurement		NA	Yes	Yes
Paddle contact display		NA	Yes	Yes

NA: Not available

The “Checks, Settings and Adjustment” section in this service manual describes only the check, setting, and adjustment that can be performed by qualified service personnel. The “Maintenance” section in the operator’s manual describes the maintenance that can be performed by the user.

The information in the operator’s manual is primarily for the user. However, it is important for service personnel to thoroughly read both the operator’s manual and service manual before starting to troubleshoot, service, maintain or repair this instrument. This is because service personnel need to understand the operation of the instrument in order to effectively use the information in the service manual.

1-2 Service Policy

WARNING

The instrument has high voltage storage capacitor, that can store lethal amounts of energy. To avoid the possibility of injury to yourself or damage to the instrument, do not install or remove any component or change switch settings while the instrument is on. Switch off the instrument, unplug the AC power cord from the instrument and remove its battery, and wait 1 minute before installing or removing any component from the instrument.

Nihon Kohden Corporation basic policy for technical service is to replace the faulty printed circuit board (PCB or board), parts or unit with a new one. This is because most of the printed circuit boards are multi-layer boards with surface mounted electrical devices. We do not recommend the replacement of electrical devices on these multi-layer printed circuit board outside the factory.

NOTE

When ordering parts or accessories from your nearest Nihon Kohden Corporation's distributor, please quote the NK part number and part name which is listed in this service manual, and the name or model of the unit in which the required part is located. This will help us to promptly attend to your needs. Always use parts and accessories recommended or supplied by Nihon Kohden Corporation to assure maximum performance from your instrument.

1. GENERAL

◆ ECG amplifier

Input signal	3-electrode selectable lead: Paddle, I, II, III, telemetry*, AUX and TEST 5-electrode**selectable lead: Paddle, I, II, III, aVR, aVL, aVF, V, telemetry*, AUX and TEST
Input impedance	Through ECG electrode: $\geq 5\text{ M}\Omega$ at 10 Hz Through paddles: $\geq 100\text{ k}\Omega$ at 10 Hz AUX: = $100\text{ k}\Omega$ at 10 Hz
CMRR	$\geq 100\text{ dB}$ (against chassis ground) when AC filter is ON
Internal noise	$\leq 30\ \mu\text{Vpp}$ when AC filter is ON
Electrode offset tolerance	$\pm 600\text{ mV}$
Defibrillator discharge protection	Provided
Frequency response	Through ECG electrodes: 0.5 to 80 Hz (–3 dB) When time constant is 0.32 s. Through paddles: 0.5 to 20 Hz (–3 dB) Telemetry: 0.4 to 40 Hz (–3 dB) AUX: 0.5 to 80 Hz (–3 dB) When time constant is 0.32 s.
Time constant	0.32 or 3.2 s
Sensitivity	10 mm/1 mV ($\times 1/2$, $\times 1$, $\times 2$, $\times 4$ selectable)
AC filter	Available
Pacing pulse rejection	Available
ESU filter	Provided for 3-electrode and 5-electrode input only
QRS sync sound	Provided with a volume control
Test waveform	Simulates QRS waveform of approx. 1 mV, 120 ms and 60 bpm
Heart rate counting range	Defibrillation and monitoring mode: 15 to 300 bpm Pacing mode: 15 to 220 bpm
Electrode detachment detection	Provided

* Available when the ZR-751V Telemetry receiver is installed and ECG signal is received.

** Requires the optional BC-755V ECG connection cable.

◆ Monitor

Effective display area	97 (W) \times 74 (H) mm
Number of traces	1 (ECG)
Sweep speed	25 mm/s
Sweep length	97 mm
Frequency response	0.05 to 80 Hz (–3 dB)
Amplitude limit	40 mm

Alphanumeric display	TEC-7511/7521: Heart rate, SpO ₂ (%)*, ECG sensitivity, ECG lead and charged energy
	TEC-7531: Heart rate, SpO ₂ (%)*, ECG sensitivity, ECG lead, charged energy, pacing current and pacing rate
Other display	Defibrillation mode: SYNC or none Charge condition: CHARGING, CHARGED Pacing mode (TEC-7531 only): FIXED MODE, DEMAND MODE AC operation marks, Battery marks (indicating remaining operation time), Sync mark, Alarm suspend mark, Messages and error messages

◆ Alarm

Heart rate	Upper limit: 20 to 300 in 5 bpm steps and off Lower limit: 15 to 295 in 5 bpm steps and off An alarm sounds and heart rate is highlighted.
SpO ₂ *	Upper limit: 51 to 99 in 1 % steps and off Lower limit: 50 to 99 in 1 % steps and off An alarm sounds and SpO ₂ % is highlighted.
Lead off alarm	An alarm sounds and a message appears. ECG LEAD OFF, TELEMETRY ECG LEADS OFF* SpO ₂ PROBE OFF*, PULSE CHECK*, PADDLE LOOSE
Alarm on/off	Provided

* Appears when the ZR-751V Telemetry receiver is installed and an SpO₂ signal is received.

◆ Recorder

Paper	FQS50-3-100 z-fold paper, RQS50-3 roll type paper
Paper speed	5, 25 mm/s (5 mm/s: Only selected in manual recording for ECG monitoring)
Types of the recording	Manual recording: Real time/delayed ECG waveform recording, report recording, trend recording, event recording, Automatic recording: Defibrillation recording, alarm recording

1. GENERAL

Real time/delayed ECG waveform recording

Recorded data

Real time/delayed ECG waveforms

Summary recording

Paper speed

25 mm /s

Recorded data

UP to 100 event data:

POWER ON/OFF, ECG, LEAD SET,
DISP PAD SET, LEADS OFF, DISP PADS OFF,
CHARGING, DEFIBRILLATION XXX J,
SYNCHRONIZED CARADIOVERSION XXX J,
DISARMED, EVENT, DEMAND MODE START,
FIXED MODE START,
PACING XXX bpm XXX mA,
PACING STOP, ALARM HR XXX,
ALARM SpO₂ XXX*

UP to 12 defibrillation reports:

A defibrillation report consists of date and time,
selected energy, TTR (Transthoracic resistance),
delivered energy, defibrillation mode,
ECG sensitivity

ECG waveforms:

Up to 4 min. ECG waveforms saved when
defibrillation is performed and 6 min. ECG
waveforms saved when the event key is pressed
and alarm occurs.

Trend recording

Paper speed

25 mm /s

Recorded data

HR trendgraph, SpO₂ trendgraphs* and trend data
tabular

Length of trend time

1, 2, 4, 8, 24 hours

Event recording

Paper speed

25 mm /s

Recorded data

Saved ECG waveforms with annotations from 4 s before
to 12 s after the event key is pressed.

Defibrillation recording

Paper speed

25 mm/s

Recorded data

Saved ECG waveforms with annotations from starts of
charge to 12 s after defibrillation

Alarm recording

Paper speed

25 mm/s

Recorded data

Saved ECG waveforms with annotations from 4 s before
to 12 s after alarm occurrence

Annotation printing

Real time/delayed ECG waveforms recording, event recording, defibrillation recording, and alarm recording

ID No., date and time, ECG lead, ECG sensitivity, AC filter ON/OFF, time constant, recording mode (REAL/DELAY) operation mode (MON, DEF, PACING), recording speed, heart rate, SpO₂* (%), transmitter channel*, event mark

* Recorded when the ZR-751V Telemetry receiver is installed and signal is received.

◆ Non-invasive pacing (TEC-7531 only)

Pacing rate

40 to 180 pulse/min in 10 pulse/min steps

Output current

8 to 200 mA in 1 mA step

Pacing modes

Demand and Fixed

◆ Battery

Type

Sealed lead-acid rechargeable battery 12 V/2.9 Ah

Capacity

Fully charged new battery at 20 °C

Minimum 50 discharges at 360 J,
minimum 2 hours continuous monitoring

Charging time

3 hours at 20 °C

Charging indications

The battery charge lamp lights when the battery is being charged.

The battery charge complete lamp lights when the battery charge is completed.

The "LOW BATTERY" message appears to indicate available battery capacity (maximum 3 discharges at 360 J)

◆ Power requirement

Line voltage

100 to 127 V AC or 200 to 240 V AC

Line frequency

50 or 60 Hz

Power input

450 VA

Power consumption

120 W (Battery operation)

1. GENERAL

◆ Safety

Safety standard	IEC 601-1 (1988) - Collateral Standard Amendment 1 (1991-11), Amendment 2 (1995-03) 601-2-4 (1983)
Types of protection against electrical shock	AC power: Class I equipment Battery power: Internally powered equipment
Degree of protection against electrical shock	Defibrillation-proof type BF applied part External paddles or disposable pads are used. Defibrillation-proof type CF applied part ECG electrodes or internal paddles are used.
Protection against harmful ingress of water	IPX 1
Degree of safety of application in the presence of a flammable anaesthetic mixture, oxygen or nitrous oxide	Equipment not suitable for use in the presence of a flammable anaesthetic mixture, oxygen or nitrous oxide
Mode of operation	Continuous operation with intermittent loading

◆ Operation conditions

Temperature	0 to 45 °C
Humidity	0 to 40 °C: 30 to 95 % RH non condensing 40 to 45 °C: 30 to 80 % RH non condensing
Atmospheric pressure	70 to 106 kPa

◆ Transport and storage conditions

Temperature	– 20 to 70 °C
Humidity	15 to 95 % RH, non condensing
Atmospheric pressure	50 to 106 kPa

◆ Dimensions and weight

344 (W) × 222 (H) × 335 (D) mm
TEC-7511/7521: Approx. 9.6 kg including battery
TEC-7531: Approx. 9.9 kg including battery

◆ Other

Protection against vibration	MIL-STD-810D method, Fig 514.3-1~3-3 curve
------------------------------	--

1-4 Composition

1-4-1 TEC-7511A/C/E/F/G/K/R Defibrillator

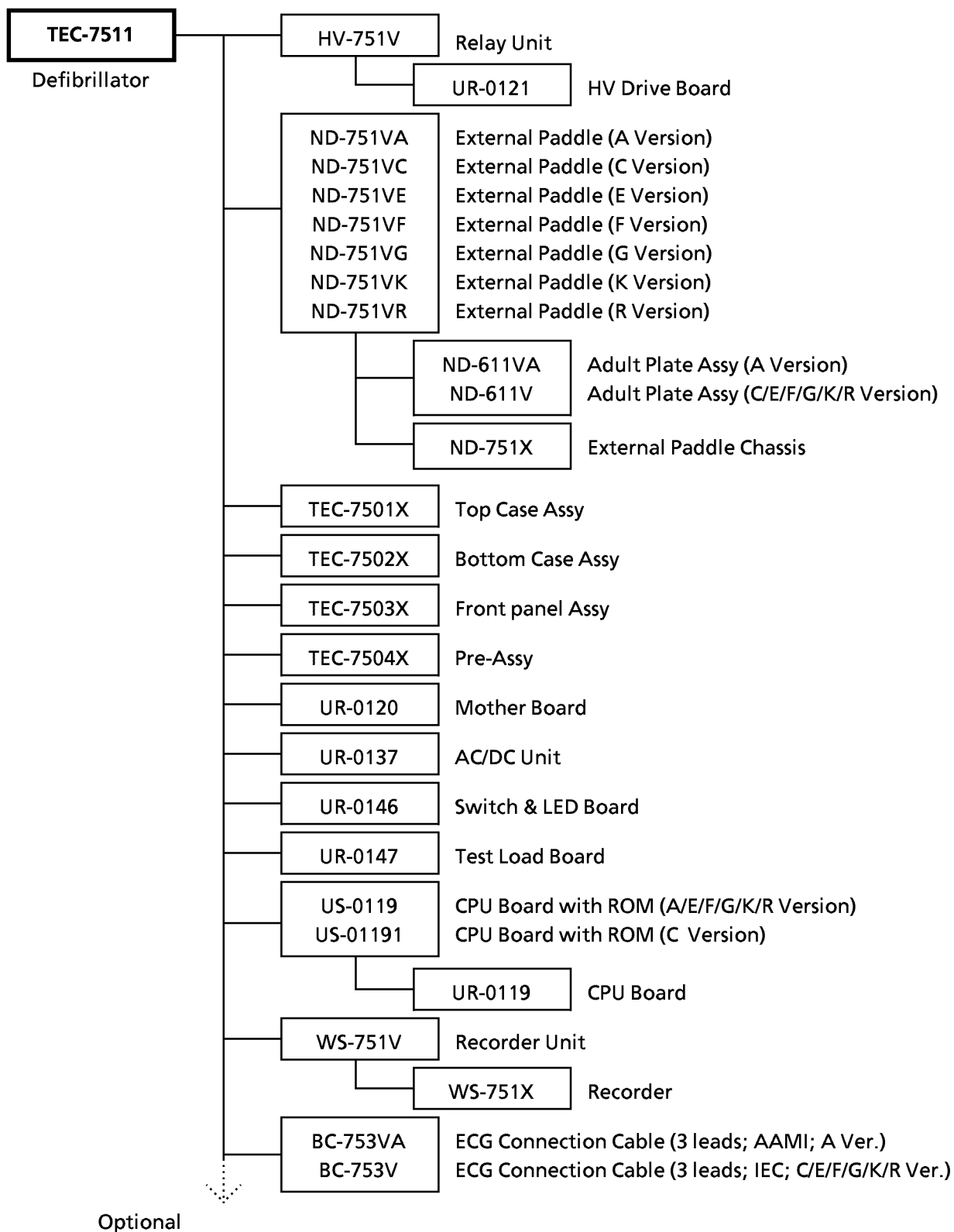

1. GENERAL

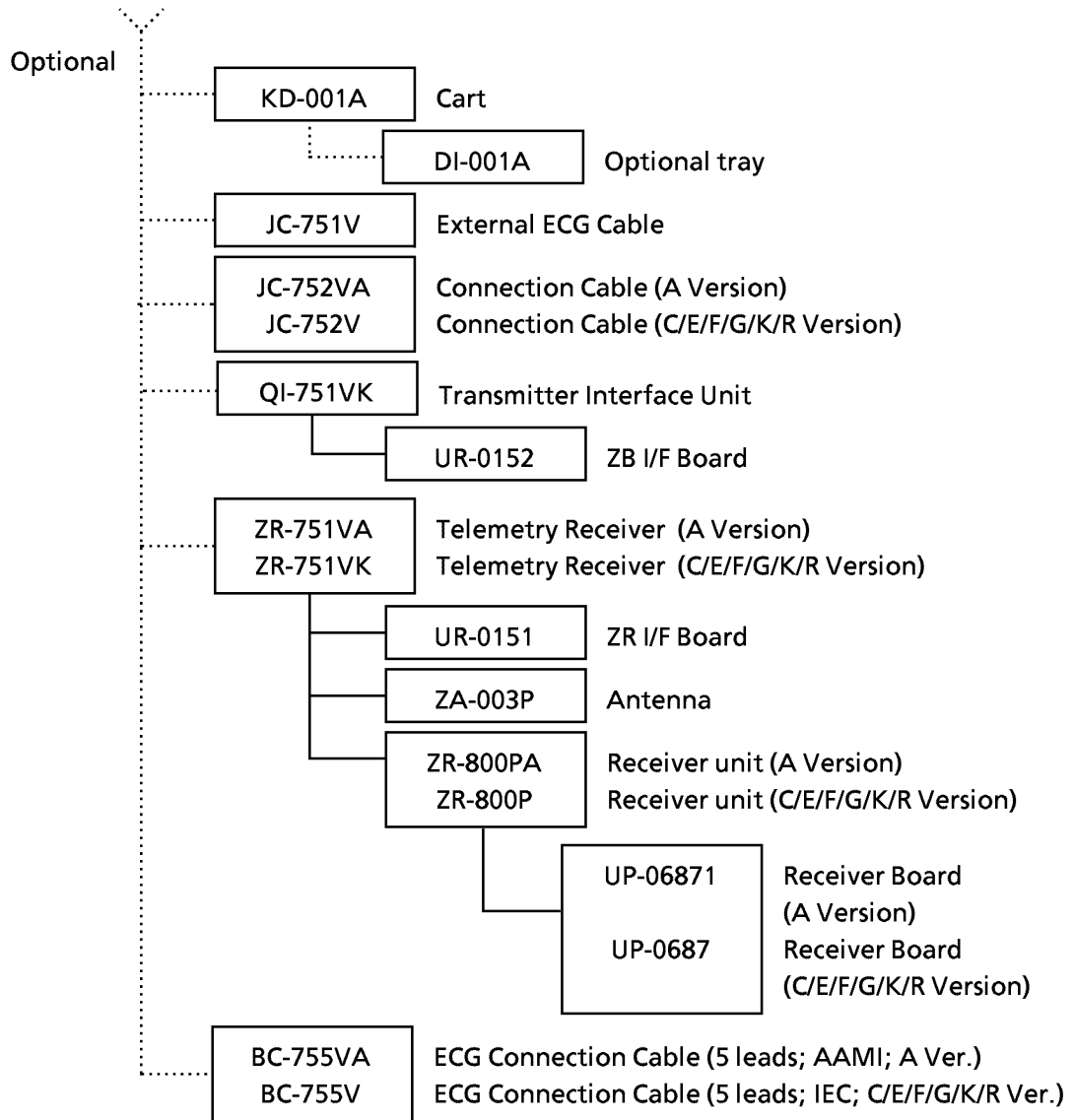

1-4-2 TEC-7521A/C/E/F/G/K/R Defibrillator

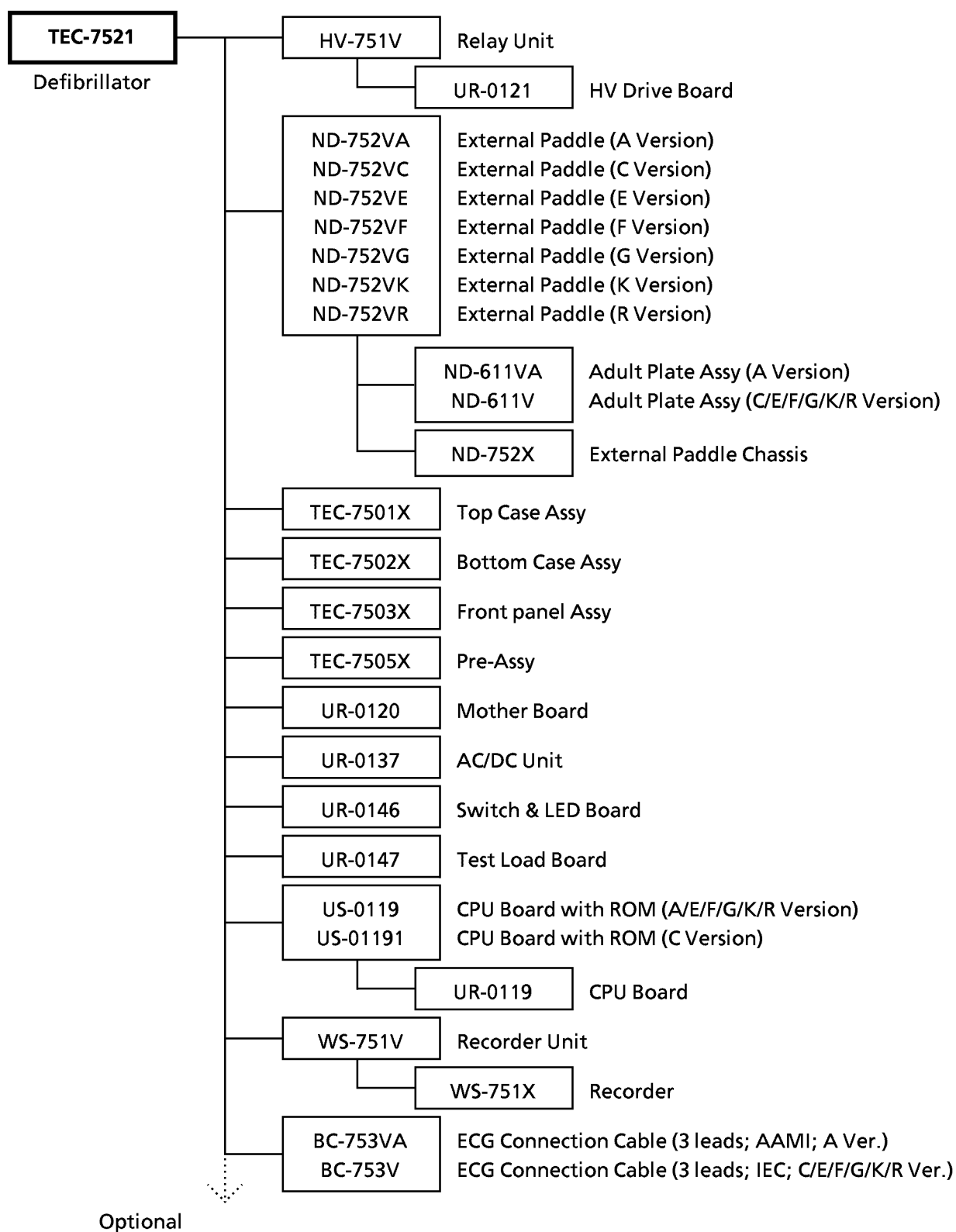

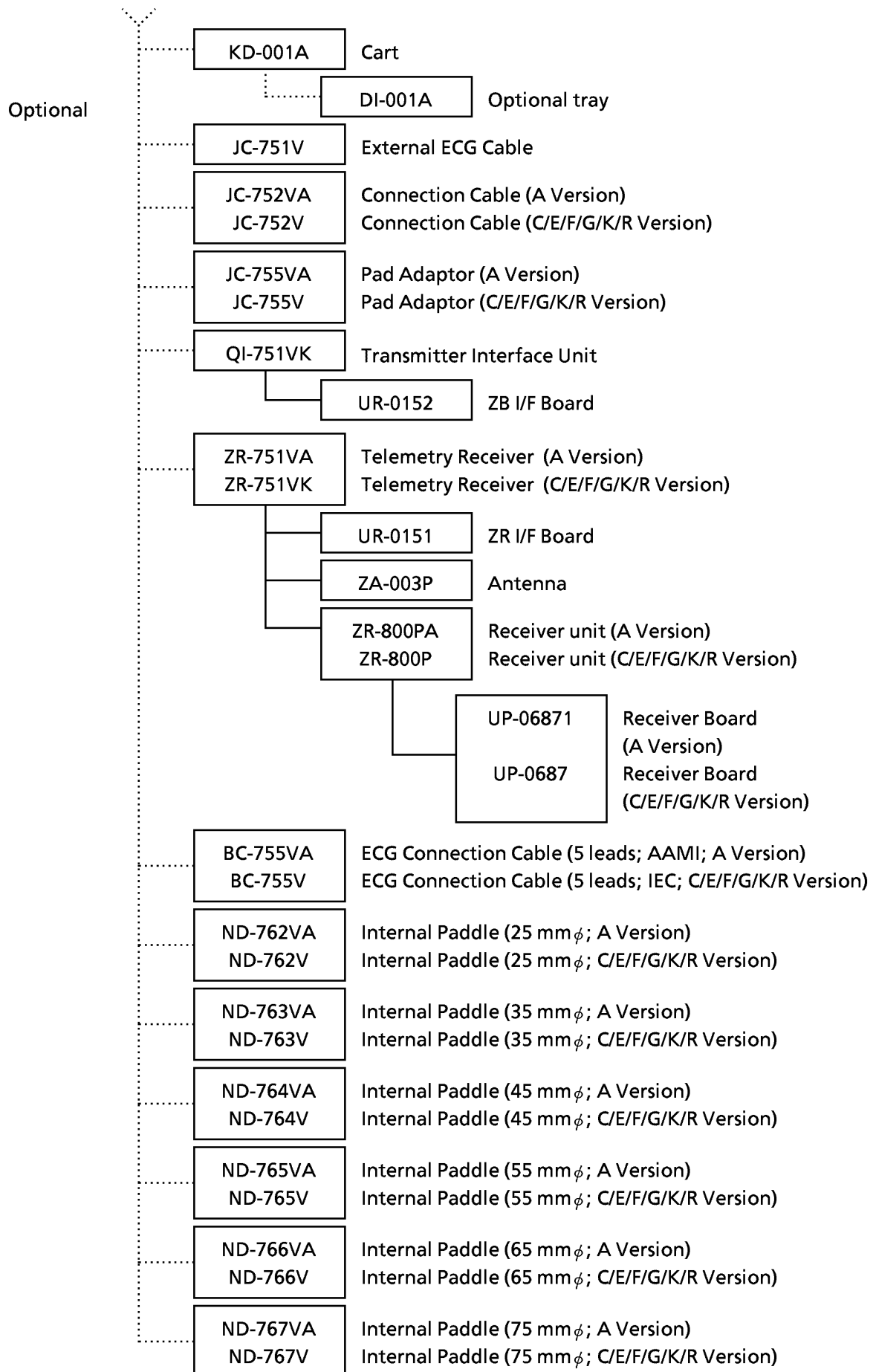

1-4-3 TEC-7531A/C/E/F/G/K/R Defibrillator

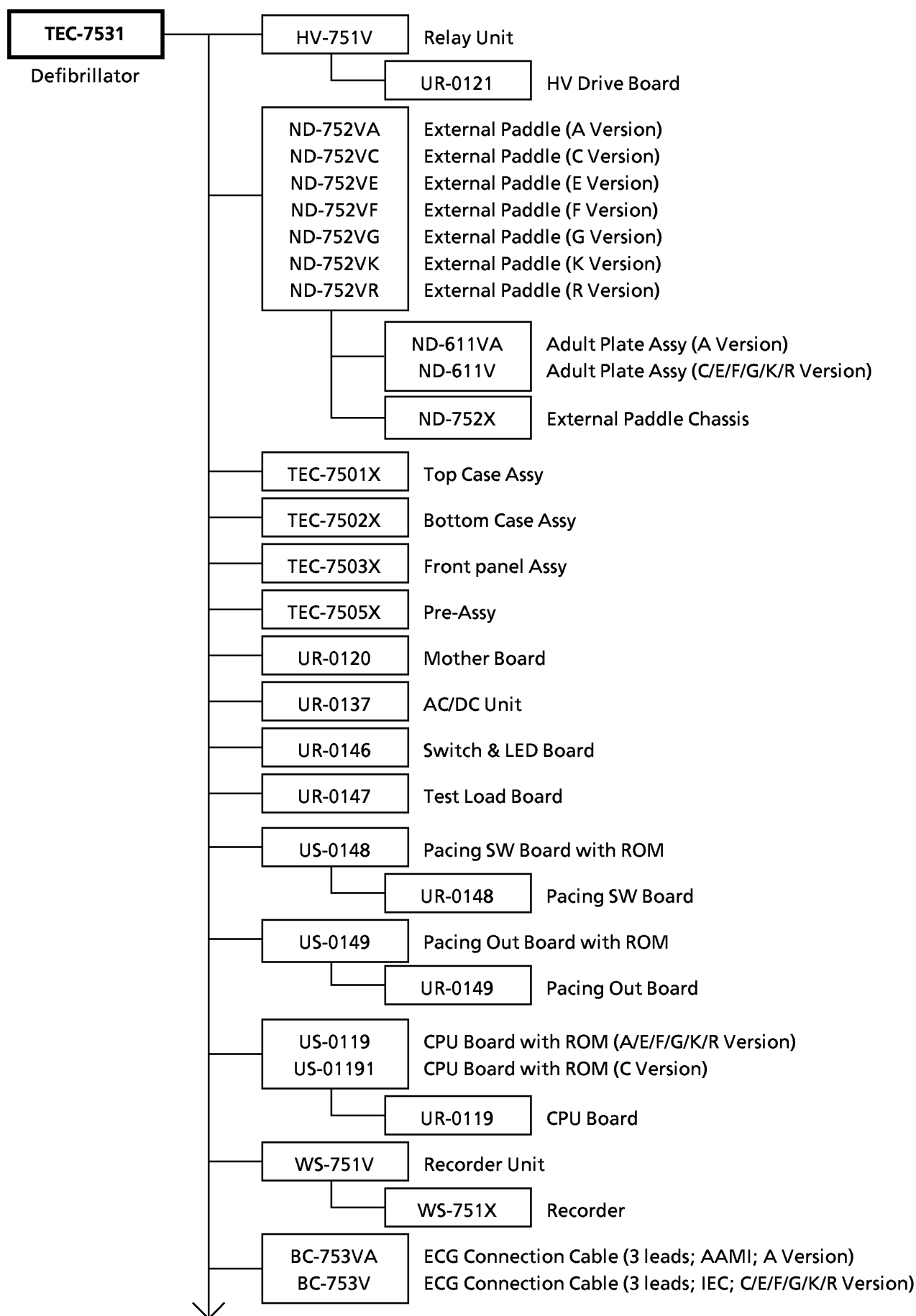

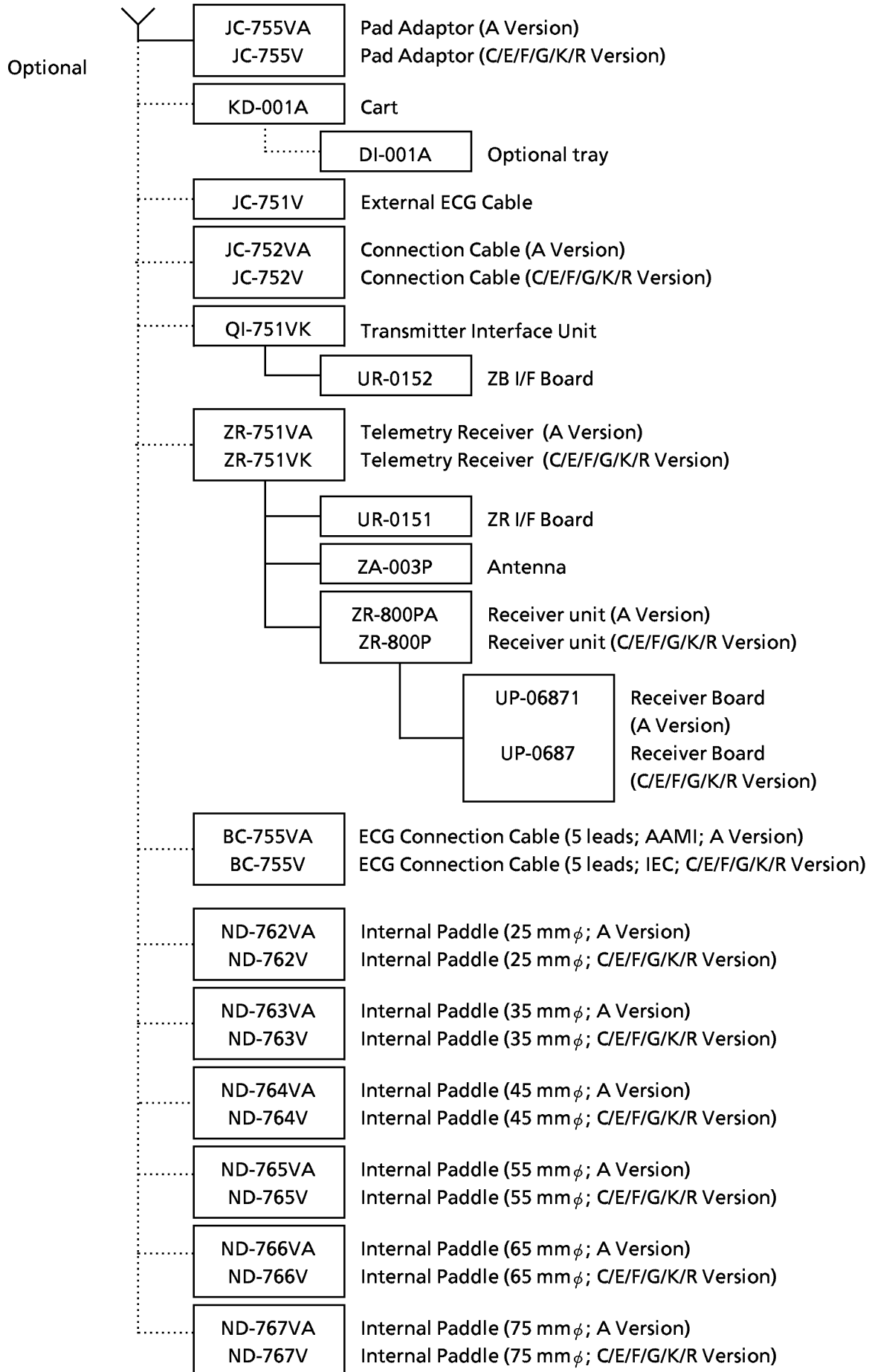

1-5 Panels and Controls

◆ Front Panel

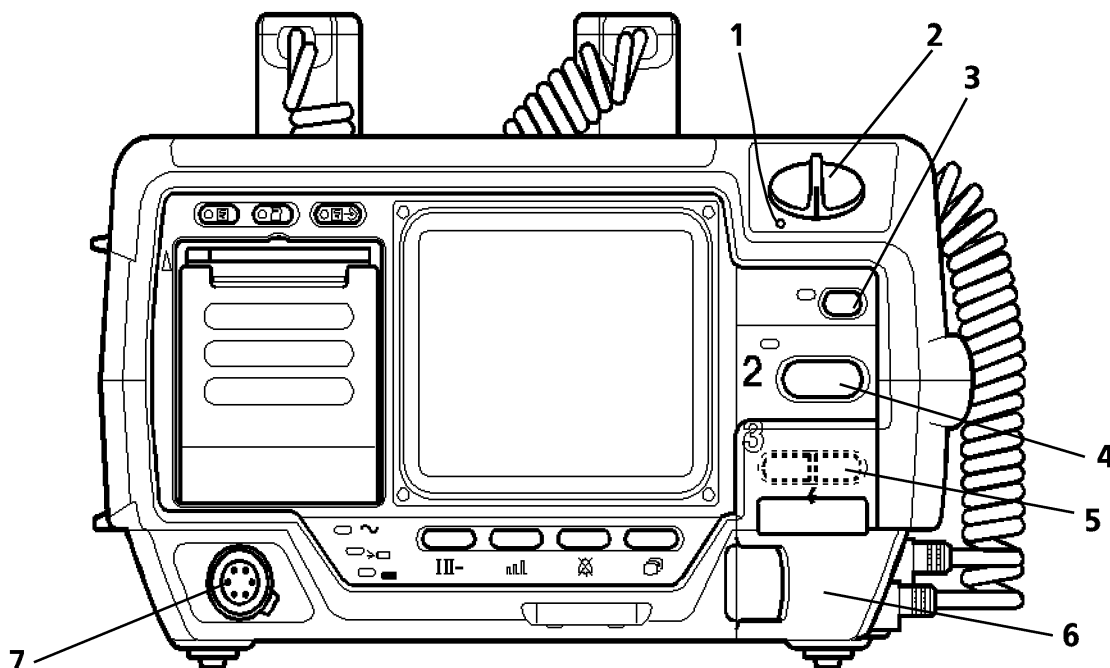

- 1 Power lamp
- 2 ENERGY/MODE SELECT control

● Defibrillation block

- 3 SYNC key/lamp Synchronization key/lamp
- 4 CHARGE key/lamp
- 5 DISCHARGE keys (TEC-7521 and TEC-7531 only)
- 6 Paddle connector (TEC-7521 and TEC-7531 only)
- 7 ECG input connector

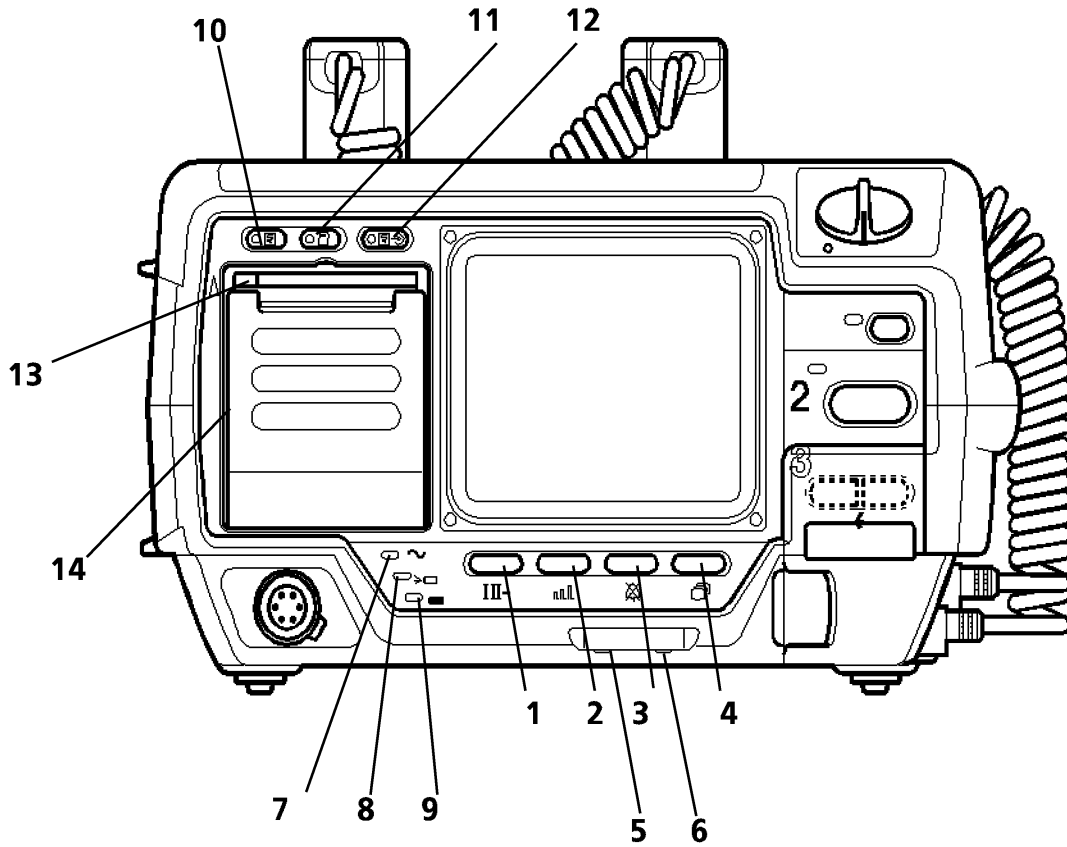

● ECG monitoring block

- 1 ECG lead key
- 2 ECG sensitivity key
- 3 Alarm suspend key
- 4 Setup key
- 5 Brightness control
- 6 Volume control
- 7 AC power lamp
- 8 Battery charging lamp
- 9 Battery charge complete lamp

● Recorder block

- 10 Record key/lamp
- 11 Report key/lamp
- 12 Event key/lamp
- 13 Magazine release lever
- 14 Thermal recorder

◆ Rear Panel

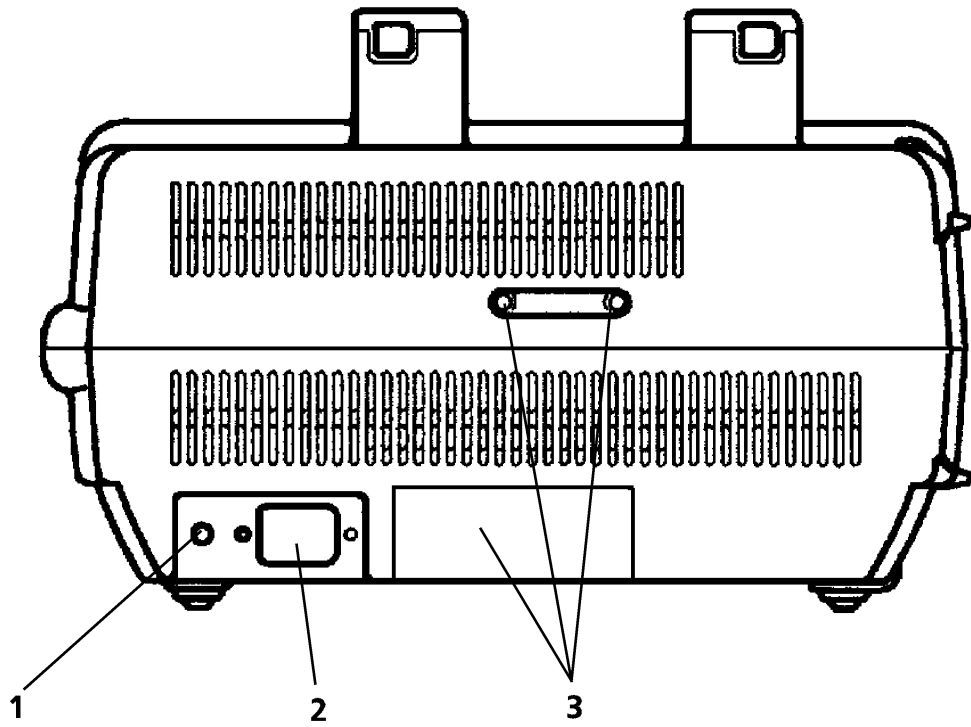

- 1 Equipotential terminal
- 2 AC SOURCE socket
- 3 Parts connecting to optional units.

◆ Top Panel

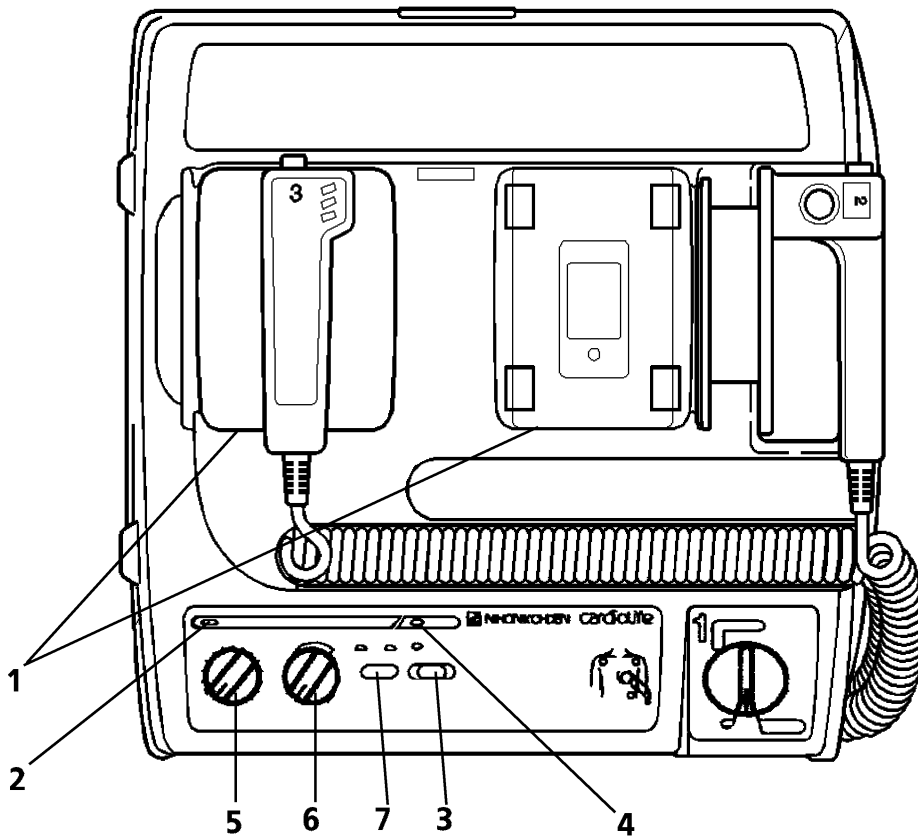

1 Paddle holders

● Pacing block (TEC-7531 only)

- 2 PACING lamp
- 3 PACING ON/OFF key/lamp
- 4 PULSE lamp
- 5 RATE
Pacing rate control
- 6 OUTPUT
Pacing current control
- 7 FIXED/DEMAND mode selection key/lamps

◆ External Paddles

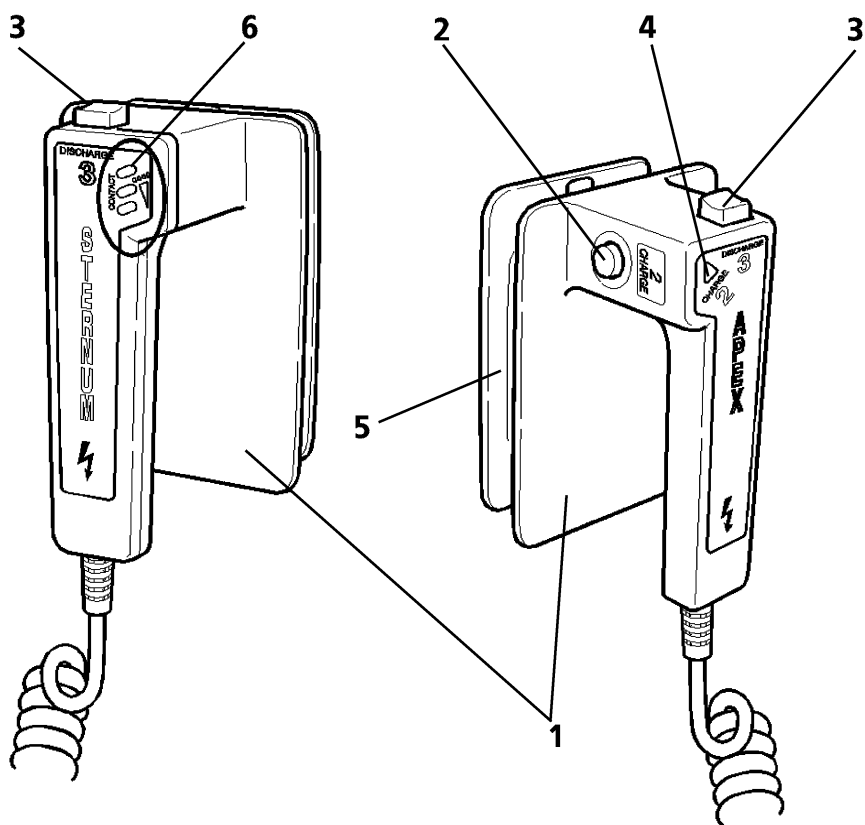

- 1 External paddle
- 2 CHARGE button
- 3 DISCHARGE buttons
- 4 CHARGE lamp
- 5 Adult electrode plate
- 6 Paddle contact indicator (TEC-7521 and TEC-7531 only)

1-6 Board/unit Location

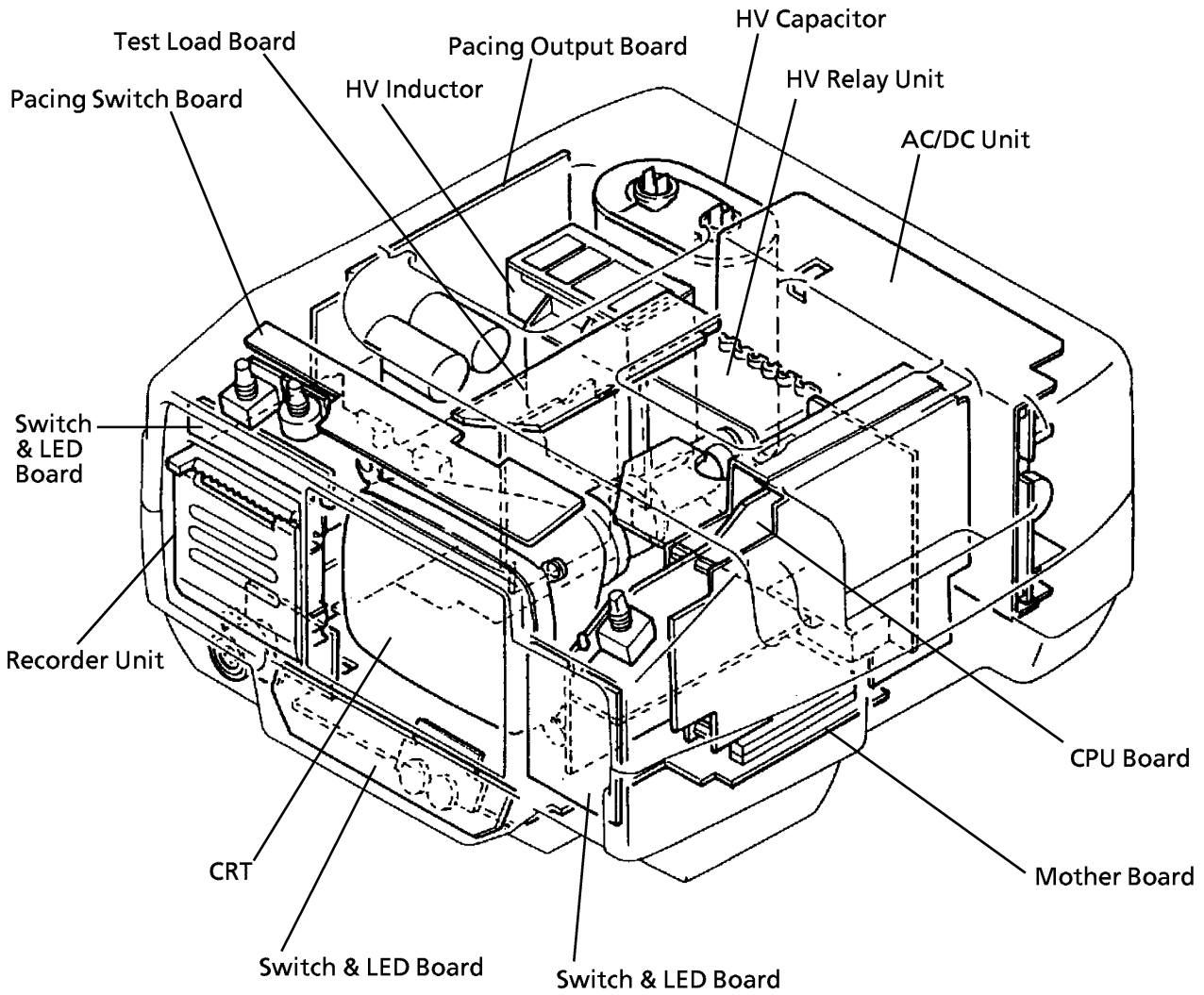

1-7 Overall Block Diagram

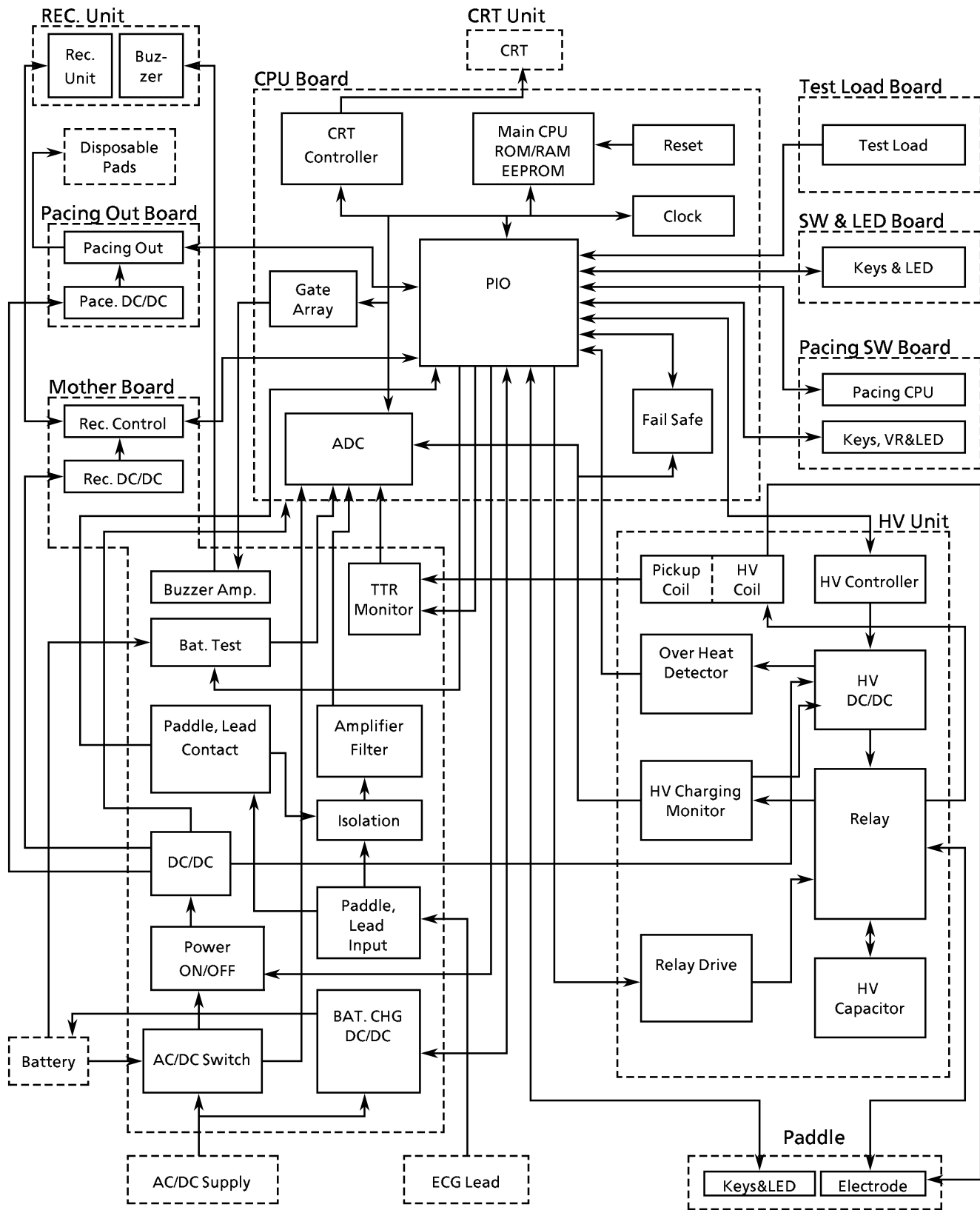

1-9 Storage and Transport

Follow these procedures when storing or transporting the instrument.

Storage

Before storing the instrument for a long time, perform the following actions:

1. Disconnect the power cord from the instrument.
2. Remove the battery of the instrument.
3. Cover the instrument with a dust cover.
4. If possible, store the instrument in its original shipment container.
5. Make sure the storage place meets the following storage conditions for the duration of the storage:

Storage Temperature – 20 to 70 °C

Storage Humidity 15 to 95% RH (non condensing)

Transport

To transport the instrument, perform the following actions:

1. Disconnect the power cord from the instrument.
2. Remove the battery of the instrument.
3. Cover the instrument with a dust cover.
4. If possible, transport the instrument in its original shipment container.

This page is intentionally left blank

Section 2 ERROR CODES, SCREEN MESSAGES AND TROUBLESHOOTING

2-1	Error Codes	2.2
2-1-1	HV Unit Related Error Codes	2.2
2-1-2	Pacing Related Error Codes	2.3
2-1-3	Switch and Key Related Error Codes	2.4
2-1-4	ROM and RAM Related Error Codes	2.6
2-2	Screen Messages	2.8
2-3	Troubleshooting	2.11
2-3-1	General Problems	2.11
2-3-2	Recording Problems	2.12
2-3-3	Monitoring Problems	2.12
2-3-4	Defibrillating Problems	2.13
2-3-5	Pacing Problems (For TEC-7351 only)	2.14
2-3-6	Option Related Problems	2.14

The instrument displays an error code or error message if it detects an error during operation or start up.

NOTE

- For problems that are not reproducible, call up the System Setup (B) screen and print the REPORT HISTORY. (Refer to the Operator’s Manual for the detail of this procedure.) This is because the instrument memory will lose the error code stored in its memory when it is turned off.
- Always check all the cable connections in the instrument before performing the action recommended in the troubleshooting tables in this section. This is because a loose cable connection can cause the instrument to display the error code.

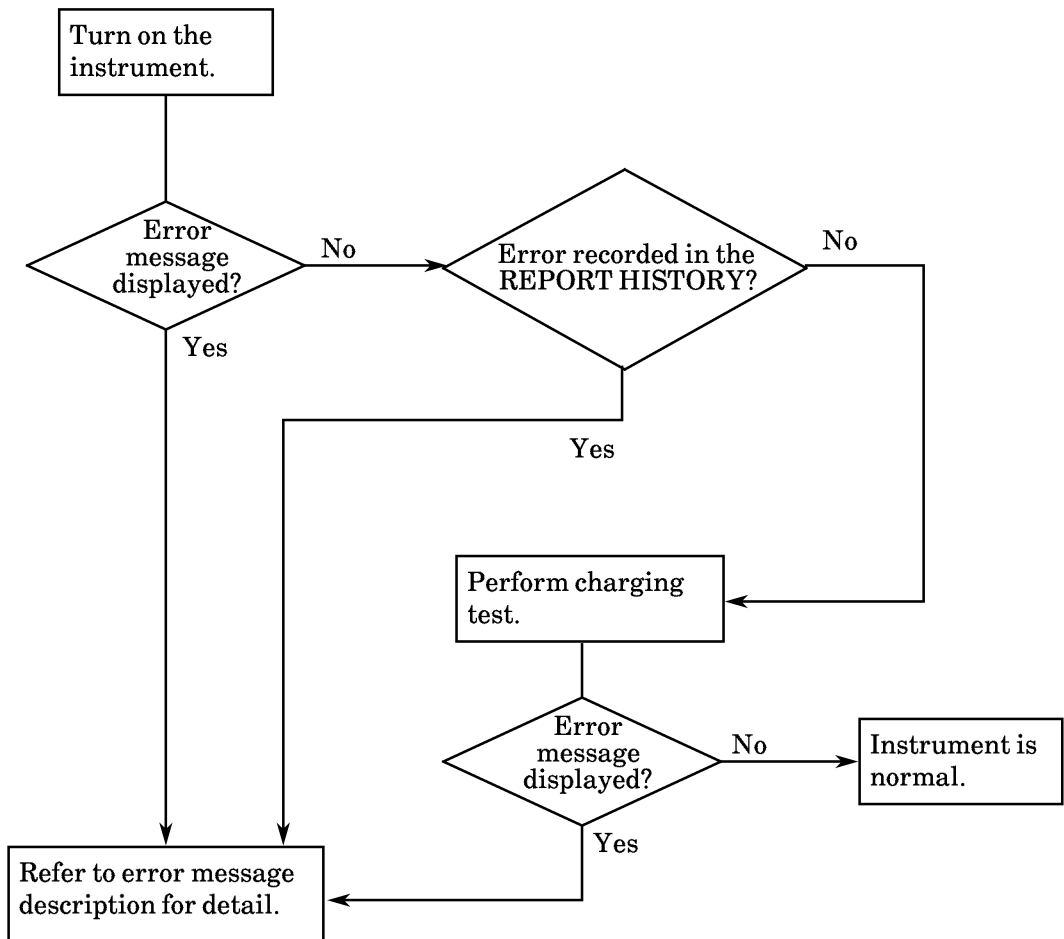

2-1 Error Codes

2-1-1 HV Unit Related Error Codes

Error Code	Condition	Possible Fault Source	Action
A501	During standby mode, the HV capacitor has more than 1J energy for one continuous second.	Faulty HV relay.	Discharge HV capacitor and replace HV relay.
A512	Within 2 s after charging has begun, the HV capacitor energy did not reach 1J.	Faulty HV relay or HV capacitor.	Replace HV relay or HV capacitor.
A513	The set voltage is not reached within the set time.	Faulty HV relay or HV capacitor.	Replace HV relay or HV capacitor.
A524	After charging, the capacitor energy falls about 50% below the set energy.	Faulty HV relay or HV capacitor.	Replace HV relay or HV capacitor.
A527	After charging, the capacitor energy is about 15% above the set energy.	Faulty HV relay.	Replace HV relay.
A528	After charging, the discharge signal becomes unstable.	Present of noise or faulty Discharge button or Switch & LED board.	Remove the source of the noise or replace the external paddle or Switch & LED board.
A529	After charging, the actual charged energy is different from the set energy.	Faulty HV relay, CPU board or HV capacitor.	Replace HV relay, CPU board or HV capacitor.
A534	In synchronized mode and after charging, the capacitor energy is about 50% below the set energy.	Faulty HV relay or HV capacitor.	Replace HV relay or HV capacitor.
A538	In synchronized mode and after charging, the discharge signal becomes unstable.	Present of noise or faulty Discharge button or Switch & LED board.	Remove the source of the noise or replace the external paddle or Switch & LED board.
A556	Internal discharge takes more than 20 s to complete.	Faulty HV relay.	Replace HV relay.
A566	HV capacitor's voltage did not reach its target value 20 s after adjusted internal discharge.	Faulty HV relay.	Replace HV relay.
A585	The voltage of the HV capacitor is over its specified voltage.	Faulty HV relay or CPU board.	Replace HV relay or CPU board.
A587	When the disposable pad is used, remnant voltage is still present in the HV 2s after external discharge.	Faulty HV relay.	Replace HV relay.

2-1-2 Pacing Related Error Codes

Error Code	Condition	Possible Fault Source	Action
P501	Pacing output rate does not match the rate setting.	Faulty Pacing Output board, Pacing Switch board or CPU board.	Replace Pacing Output board, Pacing Switch board or CPU board.
P502	Pulse width of the pacing output pulse is larger or smaller than the specified value.	Faulty Pacing Output board, Pacing Switch board or CPU board.	Replace Pacing Output board, Pacing Switch board or CPU board.
P503	Pacing output pulse's current intensity is larger than the set value.	Faulty Pacing Output board, Pacing Switch board or CPU board.	Replace Pacing Output board, Pacing Switch board or CPU board.
P504	Pacing output pulse's current intensity is smaller than the set value.	Faulty Pacing Output board, Pacing Switch board or CPU board.	Replace Pacing Output board, Pacing Switch board or CPU board.
P505	Pacing output that is not requested by the CPU is detected.	Faulty Pacing Output board, Pacing Switch board or CPU board.	Replace Pacing Output board, Pacing Switch board or CPU board.
P506	The data of the current setting volume is incorrectly read.	Faulty Pacing Switch board.	Replace Pacing Switch board.
P507	Reference voltage is different from the specified value.	Faulty Pacing Switch board or CPU board.	Replace Pacing Switch board or CPU board.
P511	Error was detected in the short-mode of the transistor.	Faulty Pacing Output board.	Replace Pacing Output board.
P512	There is a communication failure between the central processor unit of the CPU board and the central processor unit of the Pacing Switch board.	Faulty CPU board, Pacing Switch board or cable connection.	Replace CPU board, Pacing Switch board or cable connection.

2-1-3 Switch and Key Related Error Codes

Error Code	Condition	Possible Fault Source	Action
K501	ECG Lead key was activated for more than 10 s after power on.	If the key was not pressed or damaged: faulty Switch & LED board or CPU board.	Replace Switch & LED board or CPU board.
K502	ECG Sensitivity key was activated for more than 10 s after power on.	If the key was not pressed or damaged: faulty Switch & LED board or CPU board.	Replace Switch & LED board or CPU board.
K503	Alarm Suspend key was activated for more than 10 s after power on.	If the key was not pressed or damaged: faulty Switch & LED board or CPU board.	Replace Switch & LED board or CPU board.
K504	Record Start/Stop key was activated for more than 10 s after power on.	If the key was not pressed or damaged: faulty Switch & LED board or CPU board.	Replace Switch & LED board or CPU board.
K505	Report key was activated for more than 10 s after power on.	If the key was not pressed or damaged: faulty Switch & LED board or CPU board.	Replace Switch & LED board or CPU board.
K506	Event key was activated for more than 10 s after power on.	If the key was not pressed or damaged: faulty Switch & LED board or CPU board.	Replace Switch & LED board or CPU board.
K507	Panel's Charge key was activated for more than 10 s after power on.	If the key was not pressed or damaged, then the Switch & LED board or CPU board.	Replace Switch & LED board or CPU board.
K508	The paddle's Charge button was activated for more than 10 seconds after power on.	If the key was not pressed or damaged: faulty external paddle or CPU board.	Replace external paddle or CPU board.
K509	Sync key was activated for more than 10 s after power on.	If the key was not pressed or damaged: faulty Switch & LED board or CPU board.	Replace Switch & LED board or CPU board.
K510	Panel right Discharge key was activated for more than 10 s after power on.	If the key was not pressed or damaged: faulty Switch & LED board or CPU board.	Replace Switch & LED board or CPU board.
K511	Appex paddle's Discharge button was activated for more than 10 s after power on.	If the key was not pressed or damaged: faulty external paddle or CPU board.	Replace external paddle or CPU board.
K512	Pacing On/Off key was activated for more than 10 s after power on.	If the key was not pressed or damaged: faulty Switch & LED board or CPU board.	Replace Switch & LED board or CPU board.
K513	Pacing Fixed/Demand key was activated for more than 10 s after power on.	If the key was not pressed or damaged: faulty Switch & LED board or CPU board.	Replace Switch & LED board or CPU board.
K514	Panel left Discharge key was activated for more than 10 s after power on.	If the key was not pressed or damaged: faulty Switch & LED board or CPU board.	Replace Switch & LED board or CPU board.
K515	Sternum paddle's Discharge button was activated for more than 10 s after power on.	If the key was not pressed or damaged: faulty external paddle or CPU board.	Replace external paddle or CPU board.

2. ERROR CODES, SCREEN MESSAGES AND TROUBLESHOOTING

Error Code	Condition	Possible Fault Source	Action
K516	Setup key was activated for more than 10 s after power on.	If the key was not pressed or damaged: faulty Switch & LED board or CPU board.	Replace Switch & LED board or CPU board.

2-1-4 ROM and RAM Related Error Codes

Error Code	Condition	Possible Fault Source	Action
D501	Data in the ROMs is not read out correctly.	Faulty CPU board.	Replace CPU board.
D511	Data in the SRAM or EEPROM is corrupted. The system maintenance settings that changed are not save when the EEPROM Save procedure is performed.	If SRAM Clear and EEPROM Save procedures did not solve the problem, the CPU board is faulty.	Refer to the following flow-chart.

Flow-chart to Troubleshoot D511 Error Code

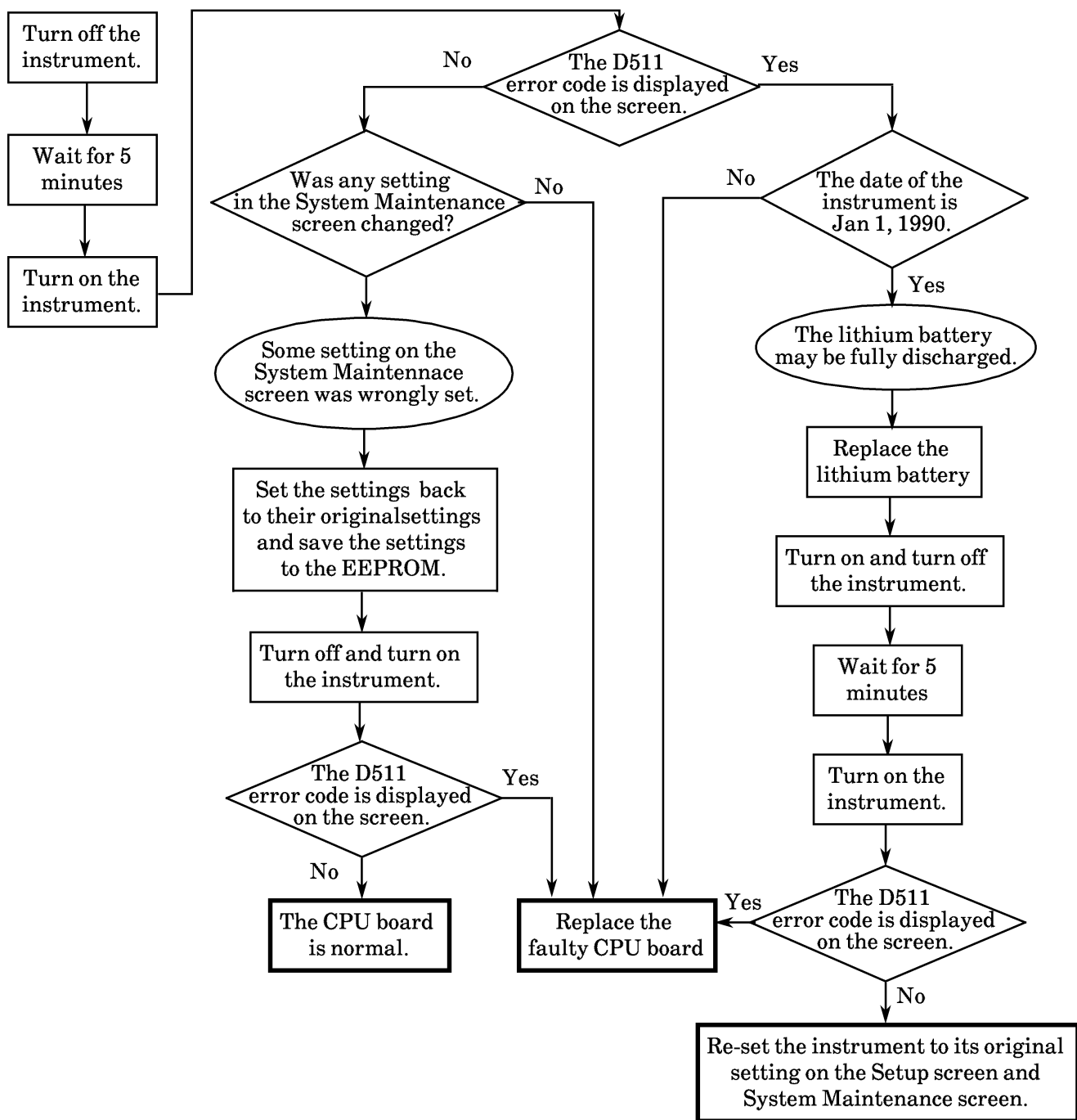

2-2 Screen Messages

Message	Possible Cause	Action
CALL	<ol style="list-style-type: none"> CALL button on the transmitter is pressed. Faulty transmitter. 	<ol style="list-style-type: none"> Check patient. Replace transmitter.
CAUTION - OVERHEATING	<ol style="list-style-type: none"> CPU board detects an over-heated high voltage drive circuit. Faulty HV relay. 	<ol style="list-style-type: none"> Turn off the power, wait 10 minutes and check the instrument. Replace the HV relay.
CHARGE BATTERY	Battery is empty.	<ol style="list-style-type: none"> Charge the battery. Use AC power operation.
CONNECT PADDLES	<ol style="list-style-type: none"> Paddles are not connected to the instrument. Faulty paddles. 	<ol style="list-style-type: none"> Connect the paddles to the instrument. Replace paddles and paddle connector on the instrument side.
ECG LEAD OFF	<ol style="list-style-type: none"> ECG electrode is detached. The electrode leads are detached. Faulty ECG connection cord. Faulty Mother board. 	<ol style="list-style-type: none"> Firmly attach the ECG electrode. Firmly attach the electrode leads. Replace ECG connection cord. Replace Mother board.
ECG LEADS OFF PACER STOP	<ol style="list-style-type: none"> Pacing is stopped because an ECG electrode is detached from the patient. The electrode leads are detached. Faulty ECG connection cord. Faulty Mother board. 	<ol style="list-style-type: none"> Reattach the ECG electrode to the patient. Firmly attach the electrode leads. Replace ECG connection cord. Replace Mother board.
FET ERROR	<ol style="list-style-type: none"> CPU board detects an error in the FET of the Mother board. Faulty Mother board. 	Replace Mother board.
HV MONITOR ERROR	<ol style="list-style-type: none"> CPU board detects an error in the high voltage monitor circuit. Faulty HV relay. 	Replace HV relay.
INSERT BATTERY	Battery is not installed.	Install the battery.
INT, DISCHARGE	<ol style="list-style-type: none"> After discharging, the discharge circuit becomes an open circuit. Faulty HV relay. Faulty paddles. 	<ol style="list-style-type: none"> Perform the energy discharge test and check the instrument. Replace HV relay. Replace paddles.
LOW BATTERY	Battery's charge is low.	<ol style="list-style-type: none"> Charge the battery. Use AC power operation.
NO REPORT DATA	<ol style="list-style-type: none"> No trend data is saved. 	<ol style="list-style-type: none"> Save trend data.
OUT OF PAPER	<ol style="list-style-type: none"> Paper magazine is opened. Recording paper is used up. Faulty recorder unit. Faulty Mother board. 	<ol style="list-style-type: none"> Close the magazine firmly. Load new paper. Replace recorder unit. Replace Mother board.

2. ERROR CODES, SCREEN MESSAGES AND TROUBLESHOOTING

Message	Possible Cause	Action
PADDLE LOOSE	<ol style="list-style-type: none"> 1. Disposable pad is not firmly attached to the patient. 2. Faulty connection between the pad and pad adaptor. 3. Faulty connection between the adaptor and the instrument. 4. Pad adaptor is not connected to the instrument when the pacing mode is selected. 5. Faulty Mother board. 6. Faulty HV relay. 	<ol style="list-style-type: none"> 1. Firmly attach the disposable pad to the patient. 2. Make sure the pad is tightly connected to the pad adaptor. 3. Make sure the pad adaptor is tightly connected to the instrument. 4. Firmly connect the pad adaptor to the instrument when the pacing mode is selected. 5. Replace Mother board. 6. Replace HV relay.
PADDLE LOOSE PACER STOP	<ol style="list-style-type: none"> 1. Pacing is stopped because the disposable pad is detached from the patient. 2. Faulty connection between the pad and pad adaptor. 3. Faulty connection between the adaptor and the instrument. 4. Faulty Pacing Output board. 	<ol style="list-style-type: none"> 1. Reattach the disposable pad to the patient or use new disposable pad. 2. Make sure the pad is tightly connected to the pad adaptor. 3. Make sure the pad adaptor is tightly connected to the instrument. 4. Replace Pacing Output board.
PULSE CHECK	<ol style="list-style-type: none"> 1. During SpO₂ measurement, the probe cannot identify the patient pulse. 2. Faulty SpO₂ probe. 3. Faulty transmitter. 	<ol style="list-style-type: none"> 1. Check the patient and make sure the SpO₂ probe is correctly placed. 2. Replace SpO₂ probe. 3. Replace transmitter.
RELAY DRIVE ERROR	<ol style="list-style-type: none"> 1. CPU board detects an error in the high voltage relay drive circuit. 2. Faulty HV relay. 	<ol style="list-style-type: none"> 1. Turn off the power and check the instrument. 2. Replace HV relay.
REPLACE BATTERY	<ol style="list-style-type: none"> 1. Battery is defective. 2. The battery is replaced while the power cord is still connected to the instrument. 	<ol style="list-style-type: none"> 1. Replace battery. 2. Remove the power cord from the instrument before replacing the battery.
REPLACE DISPOSABLE PADS	<ol style="list-style-type: none"> 1. Disposable pad is defective. 2. Faulty Mother board. 	<ol style="list-style-type: none"> 1. Replace disposable pad. 2. Replace Mother board.
REPLACE ECG ELECTRODES	<ol style="list-style-type: none"> 1. ECG electrode is defective. 2. Faulty Mother board. 	<ol style="list-style-type: none"> 1. Replace ECG electrode. 2. Replace Mother board.
REPLACE TRANSMITTER BATT	<ol style="list-style-type: none"> 1. Transmitter battery power is almost used up. 2. Faulty transmitter unit. 	<ol style="list-style-type: none"> 1. Replace transmitter battery. 2. Replace transmitter unit.
SELECT MONITOR MODE	The SETUP key was pressed when the instrument is not operating in the monitoring mode.	Change to monitoring mode and perform the operation again.
SET ENERGY BELOW 50J	<ol style="list-style-type: none"> 1. An energy above 50J is selected when internal paddles are used 2. Faulty paddles. 3. Faulty Switch & LED board 	<ol style="list-style-type: none"> 1. Select energy below 50J when internal paddles are used. 2. Replace paddles. 3. Replace Switch & LED board.

2. ERROR CODES, SCREEN MESSAGES AND TROUBLESHOOTING

Message	Possible Cause	Action
SIGNAL LOSS	<ol style="list-style-type: none"> 1. Telemetry signal strength is weak or is not received. 2. Faulty receiver unit. 3. Faulty transmitter. 	<ol style="list-style-type: none"> 1a. Replace the transmitter battery with a new one or check the location of the instrument and the transmitter. 1b. Make sure the antenna is not placed near any high frequency emitter. 1c. Make sure the channel settings are correct. 2. Replace receiver unit. 3. Replace transmitter.
SPO ₂ PROBE OFF	<ol style="list-style-type: none"> 1. SpO₂ probe is not properly attached to the patient. 2. Faulty SpO₂ probe. 3. Faulty transmitter. 	<ol style="list-style-type: none"> 1. Properly place the SpO₂ probe on the patient. 2. Replace SpO₂ probe. 3. Replace transmitter.
SUPPLY VOLTAGE TOO HIGH	Output of the AC/DC unit does not meet the power specification of the instrument.	Replace the AC/DC unit.
TELEMETRY ECG LEADS OFF	<ol style="list-style-type: none"> 1. The telemetry ECG leads are detached from the patient. 2. Faulty ECG leads. 3. Faulty transmitter. 	<ol style="list-style-type: none"> 1. Make sure the telemetry ECG leads are properly attached to the patient. 2. Replace ECG leads. 3. Replace transmitter.
TEST AT 50J	<ol style="list-style-type: none"> 1. Energy Discharge test was not performed at 50J energy setting. 2. Faulty Switch & LED board. 	<ol style="list-style-type: none"> 1. Perform discharge energy test at 50J energy setting. 2. Replace Switch & LED board.
TEST FAILED (TEC-7521 and TEC-7531 only)	<ol style="list-style-type: none"> 1. Instrument did not detect the 50J energy and 50Ω load during the energy discharge test. 2. Faulty Mother board. 3. Faulty HV inductor. 4. Faulty CPU board. 5. Faulty Test Load board. 	<ol style="list-style-type: none"> 1. Make sure the paddles are firmly inserted to their holders in the instrument and perform the 50J energy discharge test again. 2. Replace Mother board. 3. Replace HV inductor. 4. Replace CPU board. 5. Replace Test Load board.
USE AC POWER SOURCE	Power cord is disconnected during battery test.	Connect the power cord.
USE I, II ...LEAD	<ol style="list-style-type: none"> 1. The Sync key was pressed when instrument is not set to paddle synchronization. 2. The TEST lead was selected when the instrument is operating in the demand mode for pacing. 	<ol style="list-style-type: none"> 1. Set the instrument to paddle synchronization when synchronized cardioversion with paddle is required. 2. Select other lead when pacing in the demand mode.
USE I, II, .. PADS, LEAD	An operation that can only be performed during hardwired ECG monitoring is executed in telemetry ECG monitoring condition.	Make sure the operation mode or the lead selection is correct.

2-3 Troubleshooting

2-3-1 General Problems

Symptom	Possible Cause	Action
Although the instrument is connected to an external AC power source, the AC power lamp does not light up.	<ol style="list-style-type: none"> 1. Faulty power cord or cable connection. 2. Faulty AC/DC unit. 3. Faulty Switch & LED board. 4. Faulty Mother board.. 	<ol style="list-style-type: none"> 1. Check power cord or cable connection. 2. Replace AC/DC unit. 3. Replace Switch & LED board. 4. Replace Mother board.
No operation when the instrument is turned on.	<ol style="list-style-type: none"> 1. Faulty power cord or cable connection. 2. The battery is fully discharge. 3. Faulty Switch & LED board. 4. Faulty CPU board. 5. Faulty Mother board. 	<ol style="list-style-type: none"> 1. Check power cord or cable connection. 2. Connect the power cord and charge the battery. 3. Replace Switch & LED board. 4. Replace CPU board. 5. Replace Mother board.
No CRT display.	<ol style="list-style-type: none"> 1. Faulty cable connection. 2. Faulty CRT unit. 3. Faulty CPU board. 4. Faulty Mother board. 	<ol style="list-style-type: none"> 1. Check cable connection. 2. Replace CRT unit. 3. Replace CPU board. 4. Replace Mother board.
Turning the Energy/Mode Select control rotary switch does not change the operation mode.	<ol style="list-style-type: none"> 1. Faulty cable connection. 2. Faulty Switch & LED board. 3. Faulty CPU board. 	<ol style="list-style-type: none"> 1. Check cable connection. 2. Replace Switch & LED board. 3. Replace CPU board.
ECG wave is not displayed.	<ol style="list-style-type: none"> 1. Faulty cable connection. 2. Faulty Mother board. 3. Faulty CPU board. 	<ol style="list-style-type: none"> 1. Check cable connection. 2. Replace Mother board. 3. Replace CPU board.
Noise appears on the ECG wave.	<ol style="list-style-type: none"> 1. Faulty cable connection. 2. Faulty ECG electrode. 3. Faulty CPU board. 4. Faulty Mother board. 	<ol style="list-style-type: none"> 1. Check cable connection. 2a. Replace ECG electrode. 2b. Turn on the AC Filter mode. 3. Replace CPU board. 4. Replace Mother board.

2-3-2 Recording Problems

Symptom	Possible Cause	Action
Recorder cannot record.	<ol style="list-style-type: none"> 1. Faulty cable connection. 2. Faulty recorder unit. 3. Faulty CPU board. 4. Faulty Mother board. 	<ol style="list-style-type: none"> 1. Check cable connection. 2. Replace recorder unit. 3. Replace CPU board. 4. Replace Mother board.
Recorder cannot feed paper.	<ol style="list-style-type: none"> 1. Faulty cable connection. 2. Faulty recorder unit. 3. Faulty Switch & LED board. 4. Faulty CPU board. 5. Faulty Mother board. 	<ol style="list-style-type: none"> 1. Check cable connection. 2. Replace recorder unit. 3. Replace Switch & LED board. 4. Replace CPU board. 5. Replace Mother board.
Recording quality is very light or dark.	<ol style="list-style-type: none"> 1. Thermal head is dirty. 2. Faulty recorder unit. 3. Faulty Mother board. 4. Faulty CPU board. 	<ol style="list-style-type: none"> 1. Clean the thermal head. 2. Replace recorder unit. 3. Replace Mother board. 4. Replace CPU board.
Paper feeding speed is not constant or is different from the speed setting.	<ol style="list-style-type: none"> 1. Faulty recorder unit. 2. Faulty Mother board. 3. Faulty CPU board. 	<ol style="list-style-type: none"> 1. Replace recorder unit. 2. Replace Mother board. 3. Replace CPU board.
Record lamp, Report lamp or Event lamp does not light up.	<ol style="list-style-type: none"> 1. Faulty Switch & LED board. 2. Faulty CPU board. 	<ol style="list-style-type: none"> 1. Replace Switch & LED board. 2. Replace CPU board.

2-3-3 Monitoring Problems

Symptom	Possible Cause	Action
ECG lead key, ECG sensitivity key, Alarm suspend key or Setup key does not function.	<ol style="list-style-type: none"> 1. Faulty cable connection. 2. Faulty Switch & LED board. 3. Faulty CPU board. 	<ol style="list-style-type: none"> 1. Check cable connection. 2. Replace Switch & LED board. 3. Replace CPU board.
AC power lamp, Battery charging lamp or Battery charge complete lamp does not light up.	<ol style="list-style-type: none"> 1. Faulty power cord or cable connection. 2. Faulty Switch & LED board. 3. Faulty Mother board. 4. Faulty battery. 5. The battery temperature is more than 45°C. 6. Faulty AC/DC unit. 	<ol style="list-style-type: none"> 1. Check power cord or cable connection. 2. Replace Switch & LED board. 3. Replace Mother board. 4. Replace battery. 5. Cool the instrument. 6. Replace AC/DC unit.
Brightness control knob does not function.	<ol style="list-style-type: none"> 1. Faulty cable connection. 2. Faulty Brightness Control knob. 3. Faulty CRT unit. 	<ol style="list-style-type: none"> 1. Check cable connection. 2. Replace Brightness Control knob. 3. Replace CRT unit.
Volume knob does not function.	<ol style="list-style-type: none"> 1. Faulty cable connection. 2. Faulty Mother board. 3. Faulty recorder unit. 	<ol style="list-style-type: none"> 1. Check cable connection. 2. Replace Mother board. 3. Replace recorder unit.

2-3-4 Defibrillating Problems

Symptom	Possible Cause	Action
The instrument can be charged but cannot perform discharging.	<ol style="list-style-type: none"> 1. Faulty paddle. 2. Faulty Switch & LED board. 3. Faulty cable connection. 4. Faulty HV relay. 5. Faulty CPU board. 	<ol style="list-style-type: none"> 1a. Replace paddle. 1b. Replace socket insulator. 2. Replace Switch & LED board. 3. Check cable connection. 4. Replace HV relay. 5. Replace CPU board.
Cannot perform charging.	<ol style="list-style-type: none"> 1. Faulty paddle. 2. Faulty Switch & LED board. 3. Faulty cable connection. 4. Faulty HV relay. 5. Faulty HV capacitor. 6. Faulty Mother board. 7. Faulty CPU board. 	<ol style="list-style-type: none"> 1. Replace paddle. 2. Replace Switch & LED board. 3. Check cable connection. 4. Replace HV relay. 5. Replace HV capacitor. 6. Replace Mother board. 7. Replace CPU board.
Charge lamp does not blink or light.	<ol style="list-style-type: none"> 1. Faulty paddle. 2. Faulty Switch & LED board. 3. Faulty cable connection. 4. Faulty Mother board. 5. Faulty CPU board. 	<ol style="list-style-type: none"> 1. Replace paddle. 2. Replace Switch & LED board. 3. Check cable connection. 4. Replace Mother board. 5. Replace CPU board.
Paddle contact indicator does not light. (For TEC-7521 and TEC-7531 only.)	<ol style="list-style-type: none"> 1. Faulty paddle. 2. Faulty cable connection. 3. Faulty Mother board. 4. Faulty CPU board. 	<ol style="list-style-type: none"> 1. Replace paddle. 2. Check cable connection. 3. Replace Mother board. 4. Replace CPU board.
Cannot switch to synchronized mode.	<ol style="list-style-type: none"> 1. Faulty Switch & LED board. 2. Faulty CPU board. 	<ol style="list-style-type: none"> 1. Replace Switch & LED board. 2. Replace CPU board.

2-3-5 Pacing Problems (For TEC-7351 only)

Symptom	Possible Cause	Action
Cannot set the pacing output current.	<ol style="list-style-type: none"> 1. Faulty cable connection. 2. Faulty Pacing Switch board. 	<ol style="list-style-type: none"> 1. Check cable connection. 2. Replace Pacing Switch board.
Cannot set the pacing output rate.	<ol style="list-style-type: none"> 1. Faulty cable connection. 2. Faulty Pacing Switch board. 3. Faulty CPU board. 	<ol style="list-style-type: none"> 1. Check cable connection. 2. Replace Pacing Switch board. 3. Replace CPU board.
No pacing output.	<ol style="list-style-type: none"> 1. Faulty cable connection. 2. Faulty Pacing Output board. 3. Faulty Pacing Switch board. 4. Faulty CPU board. 5. Faulty Mother board. 	<ol style="list-style-type: none"> 1. Check cable connection. 2. Replace Pacing Output board. 3. Replace Pacing Switch board. 4. Replace CPU board. 5. Replace Mother board.
Instrument cannot switch to the pacing mode.	<ol style="list-style-type: none"> 1. Faulty cable connection. 2. Faulty Switch & LED board. 3. Faulty CPU board. 	<ol style="list-style-type: none"> 1. Check cable connection. 2. Replace Switch & LED board. 3. Replace CPU board.
Pacing lamp, Pacing ON/Off lamp, Pulse lamp or Fixed/Demand lamp does not light or blink.	<ol style="list-style-type: none"> 1. Faulty cable connection. 2. Faulty Pacing Switch board. 3. Faulty Pacing Output board. 4. Faulty CPU board. 	<ol style="list-style-type: none"> 1. Check cable connection. 2. Replace Pacing Switch board. 3. Replace Pacing Output board. 4. Replace CPU board.
Pacing On/Off key or Mode Selection key does not function.	<ol style="list-style-type: none"> 1. Faulty Pacing Switch board. 2. Faulty CPU board. 	<ol style="list-style-type: none"> 1. Replace Pacing Switch board. 2. Replace CPU board.

2-3-6 Option Related Problems

Symptom	Possible Cause	Action
Receiver unit cannot receive telemetry signals.	<ol style="list-style-type: none"> 1. Faulty cable connection. 2. Faulty transmitter. 3. Faulty receiver unit. 4. Faulty CPU board. 	<ol style="list-style-type: none"> 1. Check cable connection. 2. Check transmitter. 3. Replace receiver unit. 4. Replace CPU board.
Transmitter unit cannot transmit telemetry signals.	<ol style="list-style-type: none"> 1. Faulty cable connection. 2. Faulty receiver unit. 3. Faulty transmitter. 4. Faulty CPU board. 	<ol style="list-style-type: none"> 1. Check cable connection. 2. Check receiver unit. 3. Replace transmitter. 4. Replace CPU board.

Section 3 BOARD/UNIT DESCRIPTION

3-1	CPU Board	3.2
3-2	Mother Board	3.5
3-3	Switch and LED Board	3.9
3-4	Test Load Board	3.10
3-5	Pacing Switch Board (For TEC-7531 Only)	3.11
3-6	Pacing Output Board (For TEC-7531 Only)	3.12
3-7	HV Relay Unit	3.14
3-8	External Paddles	3.16
3-9	Recorder Unit	3.17
3-10	ZR-I/F Unit (Optional)	3.18
3-11	ZB I/F Unit (Optional)	3.19

This section provides theory of operation for the instrument. The theory describes at a high level the functional operation of the following major electronic assemblies:

- CPU board
- Mother board
- Switch and LED board
- Test Load board
- Pacing Switch board (for TEC-7531 only)
- Pacing Output board (for TEC-7531 only)
- HV relay unit

3-1 CPU Board

The CPU board, based on a TMP68303 Central Processing Unit (CPU), provides the processing power to run the instrument. The CPU board performs a variety of functions:

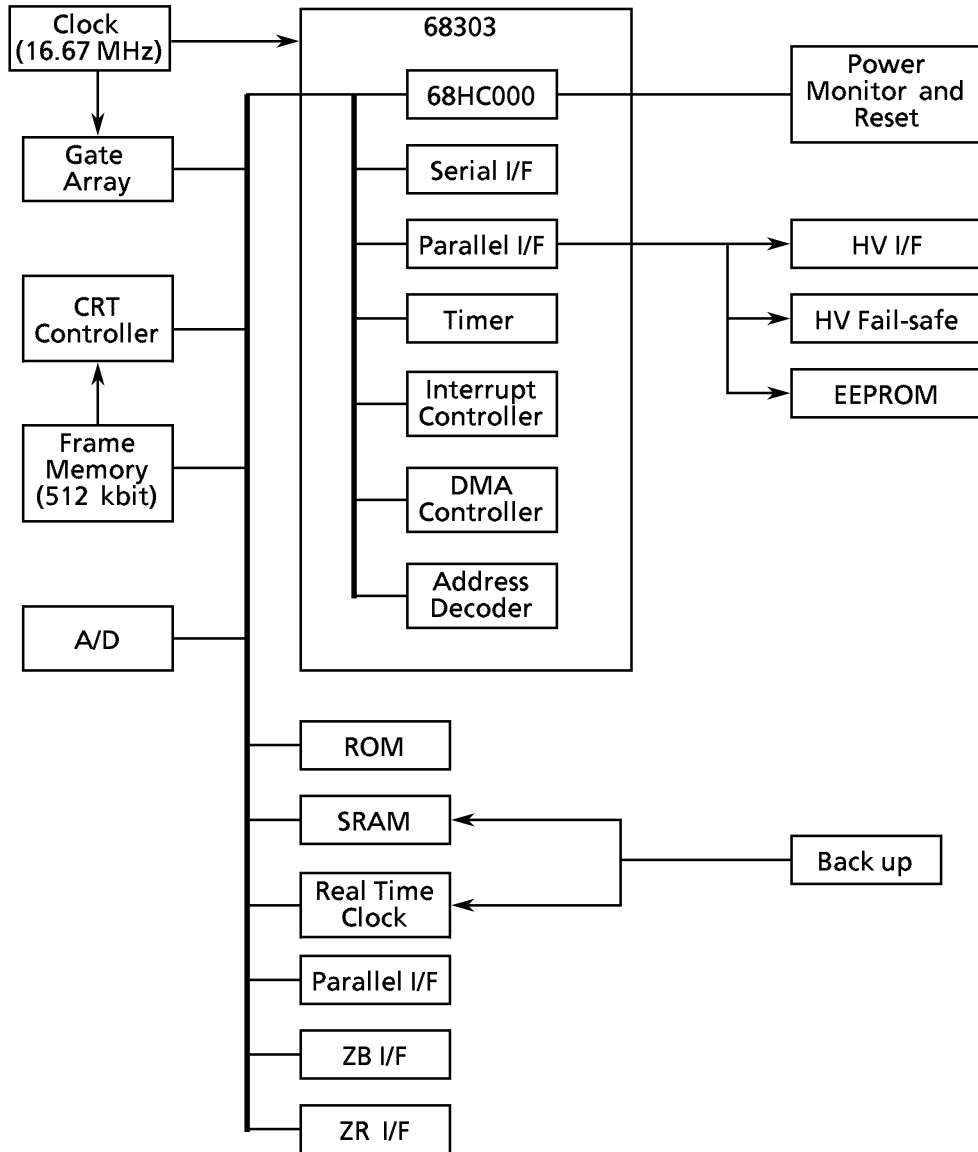

Serial Interface

The serial interface allows the sending and receiving of serial data between the CPU board and ZB-800P transmitter and pacing unit.

DMA Control

The Direct Memory Access (DMA) controller is responsible for transferring data from the A/D converter and transferring the alphanumeric data to the recorder.

High Voltage Components Control

The CPU board provides the control for the high voltage capacitor charging and internal and external discharging of the high voltage components.

Discharging Fail-safe

The CPU board provides the discharging fail-safe function by comparing the energy setting of the energy select knob and the energy stored in the high voltage capacitor. Under normal conditions, the energy stored in the high voltage capacitor matches the energy setting of the energy select knob. However, under a fault condition, the energy stored in the high voltage capacitor can be different from the energy select knob setting. When the CPU determines that the difference between the energy select knob setting and the energy stored in the high voltage capacitor is larger than the allowable range, it disables the external discharge circuit and internally discharges the stored energy of the high voltage capacitor.

Thermal Head Data Transfer Timing

The CPU board provides the timing clock for the transfer of the data to the thermal head.

Real Time Clock

The real time clock in the CPU board provides the date and time data of the instrument. The real time clock is backed up by a lithium battery.

CRT Control

The CRT controller on the CPU board controls the way the graphic and numerics are displayed on the CRT.

CRT and Display

The 5.5 inch (139 mm) CRT displays information using a raster pattern. The total usable raster area is 800 dots horizontal \times 256 vertical lines. However, the CRT controller in the display circuit has a display character size of 8 dots by 8 raster. This gives a screen display of 200 characters by 32 lines. The CRT controller controls the drawing of the raster pattern on the frame memory (SRAM). The raster pattern in the frame memory is then changed into video signal before it is output to the CRT.

EEPROM

The EEPROM stores the default settings of the instrument. The instrument restores the default settings to the SRAM after a backup error had occurred in the SRAM.

EEPOT

The system software of the instrument uses the EEPOT to adjust the gain of the ECG waveform data.

3. BOARD/UNIT DESCRIPTION

ZB Interface

The ZB interface handles the communication signal between the instrument and the ZB-800P transmitter. Serial communication signal from the transmitter is processed by the CPU through its built-in RS-232C interface, and parallel communication signal from the instrument is first latched by the buffer, then converted into 14-bit serial communication before it is output to the ZB-800P transmitter. For analog ECG signal, the ZB interface receives it from the mother board and outputs it to the ZB-800P transmitter.

ECG waveform output

1 V/mV (analog, no offset)

Power requirements

+ 8 V, 20 mA

ZR Interface

The ZR interface handles the communication between the instrument and the ZR-800P receiver unit. A frame gate array, under the timing provided by the ZR-800P receiver unit, converts the serial data from the ZR-800P receiver unit into parallel data.

Power requirements

+ 8 V, 150 mA

Recording Control

The CPU board provides the control signals to the recorder unit. These signals include the data, clock, latch and strobe for the thermal recording head.

Paper and Door Status Control

The CPU board receives the output of the recorder's paper and door status detection circuit in the mother board, and outputs the corresponding control and data signals to the display unit, recorder unit or alarm generation circuit.

3-2 Mother Board

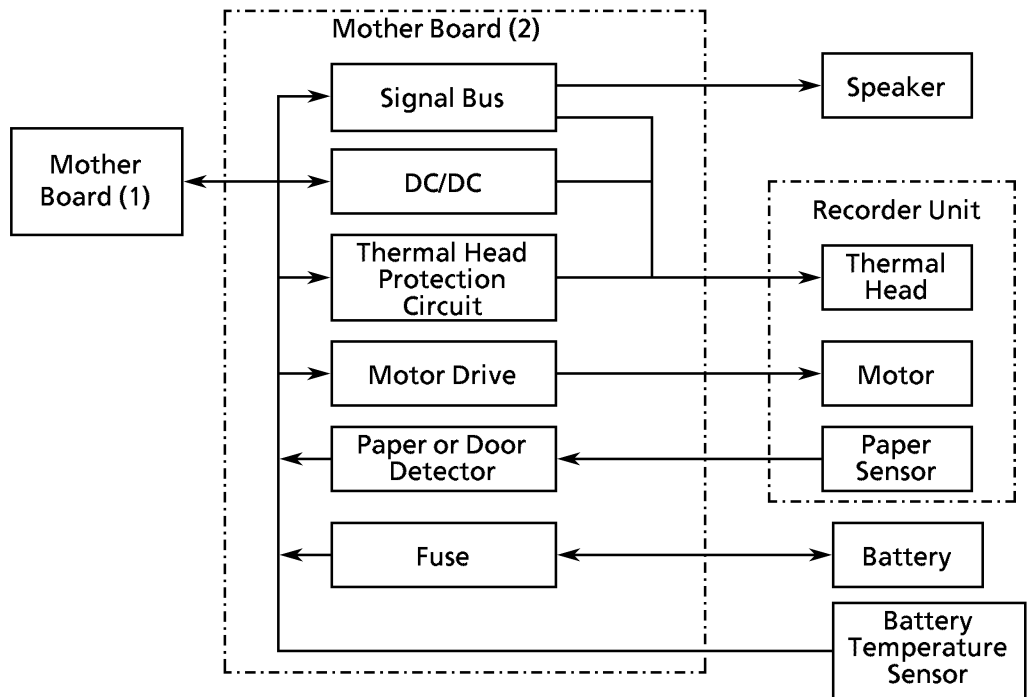
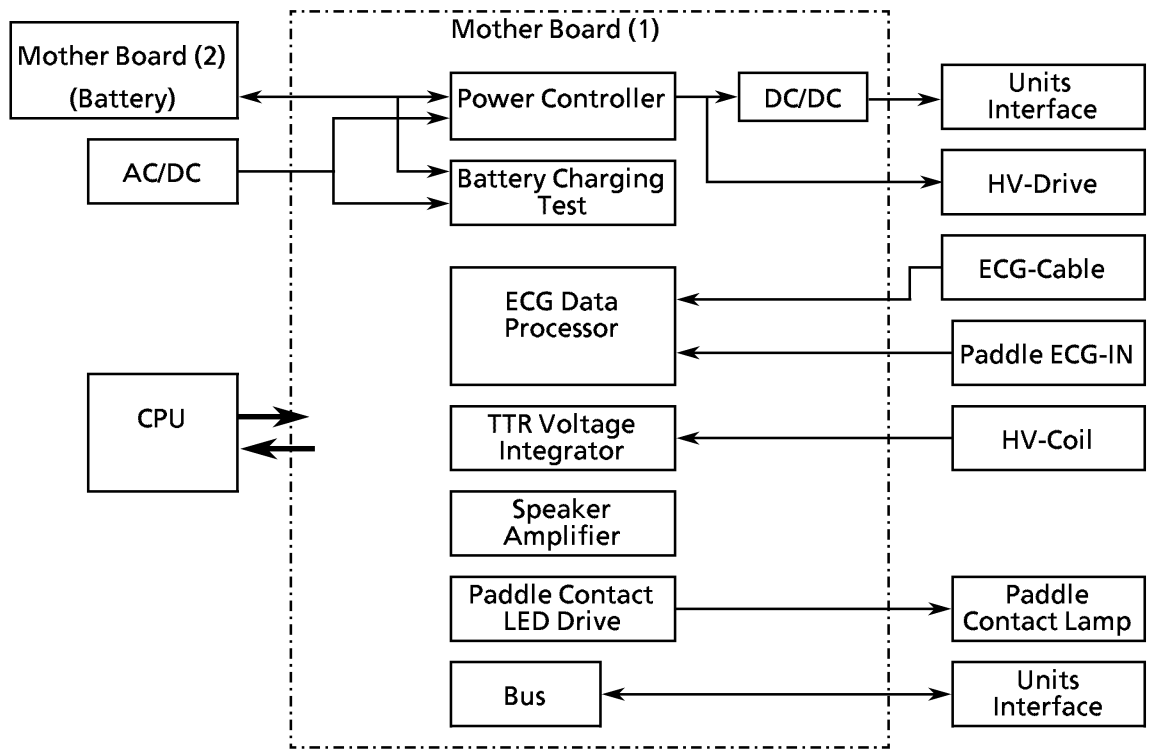

The Mother board consists of 2 printed circuit boards that are permanently joined together and perform as if they are one printed circuit board. The variety of functions that the Mother board performs are:

3. BOARD/UNIT DESCRIPTION

Power Control

The instrument runs on AC power, car battery, or regular battery. The Mother board determines which of these power sources is available to the instrument. If the instrument is running on battery power when an AC power source is made available to the instrument, the Mother board automatically switches to AC power mode. During operation, the instrument monitors the voltage of the battery and the output voltage of the AC/DC board. If the instrument is powered by only the battery, it shuts down all its operations when the battery's voltage falls below about 10 V (during monitoring) or about 9 V (during high voltage charging).

DC/DC Conversion

The Mother board converts the + 24 V output by the AC/DC board into + 12 V, + 8 V, ± 6 V, and + 5 V. However, if the instrument is run by battery power, the battery's output power range of + 9 V to 13 V is used to generate the above power supplies. The generated power supplies are used as follows.

+ 12 V	For CPU board, HV-Drive board, CRT unit and Mother board (2)
+ 8 V	For CPU board
+ 6 V	For CPU board and Pacing unit (if available)
- 6 V	For CPU board and Pacing unit (if available)
+ 5V	For CPU board, Pacing unit (if available) and Mother board (2)
+ 24V	For Recorder unit

Battery Charging

During AC operation mode, the Mother board uses two charging modes to charge the battery, if it is installed. The Mother board uses the fast charging mode to charge the battery to its near full charge point and then changes to the trickle charging mode to maintain the battery voltage at its full charge point. During the charging process, the Mother board monitors the temperature sensor placed near battery. The Mother board adjust the charging operation according to the temperature of the battery and stops the charging process if the battery temperature rises above 60°C. The battery impedance is also monitored during the charging process and if the Mother board finds that this impedance is high, it informs the CPU board that the battery is faulty. The status of the whole charging process is monitored by the Mother board which in turn outputs the control signals to the battery charging lamp and battery charge complete lamp.

Battery Test

The Mother board provides the function to test the battery and display the result of the test.

ECG Data Processing

The Mother board provides the necessary ECG processing circuits to process the raw ECG signal it received from the paddles or the ECG electrodes via the ECG input connector.

The ECG processing circuit performs the following functions:

- selects the input ECG signal from the paddles or ECG input connector
- amplifies the 1 mV level ECG signal from the paddles or ECG input connector for A/D conversion
- generates CAL waveform for recording
- generates TEST waveform on the screen
- detects for leads off condition for ECG signal received from the ECG input connector.
- detects for pacing pulse
- measures paddle impedance
- inputs the polarized voltage for A/D conversion
- removes noise from the ECG signal received from the ECG input connector

TTR Voltage Integration

The Mother board integrates the voltage developed in the secondary winding of the HV inductor during the discharge. The result of this integration is output to the CPU board for the calculation of the Transthoracic Resistance (TTR) and delivered energy.

Sound Amplification

The Mother board amplifies the QRS synchronizing sound, alarm sound, key click sound, and charging sound output from the CPU board and outputs the amplified signals to the buzzer in the recorder unit.

Paddle Contact LED Drive

The Mother board under the control of the CPU board outputs the LED driving signal to the paddle contact lamp on the external paddle.

Units Interface

The Mother board provides the connection interface between the various components in the instrument, such as the recorder unit, speaker, battery's thermistor, and the battery via the protection fuse, and the CPU board.

Recorder's Motor Drive

The Mother board under the control of the CPU board outputs the motor driving signal to the motor in the recorder unit.

3. BOARD/UNIT DESCRIPTION

Thermal Head Protection

A signal that continuously turns on a dot in the thermal head can damage the dot. This kind of signal is generated when the instrument is turned on or when there is a fault in the CPU. The Mother board monitors this signal and switches it off if it is turned on too long or when there is a failure in the CPU board.

3-3 Switch and LED Board

The Switch and LED board consists of four printed circuit boards that are connected to each other by cables. This board provides the interface between the CPU board and the rotary switch, keys and LEDs on the defibrillation, monitoring and recorder panels of the instrument.

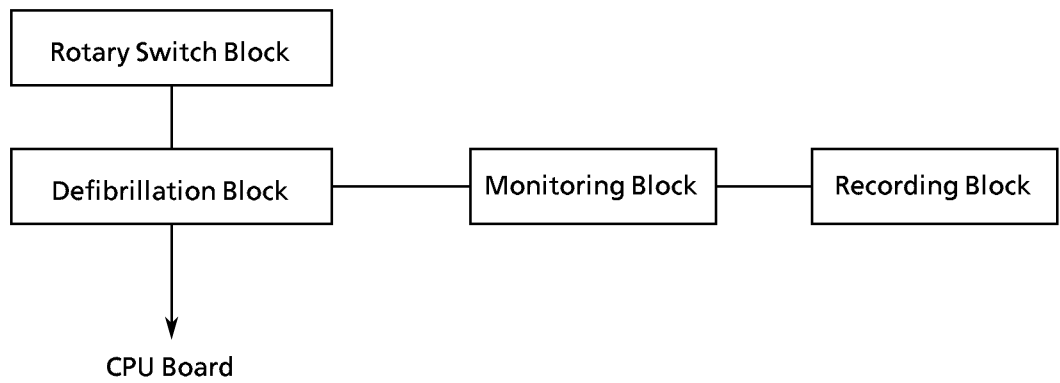

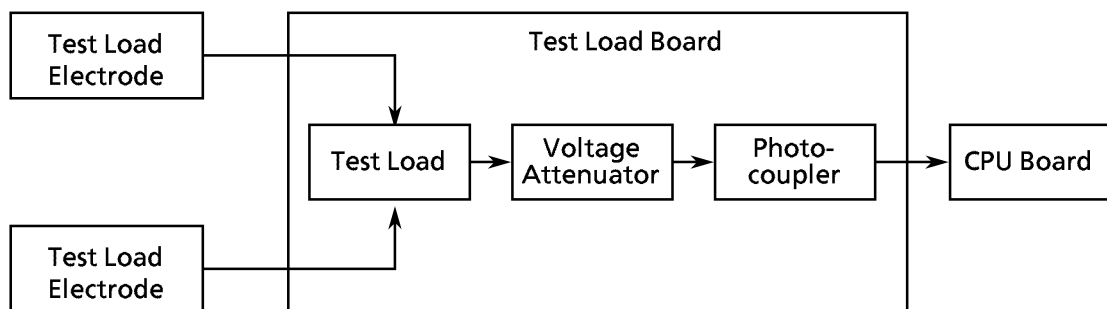
3-4 Test Load Board

The Test Load board dissipates the energy generated by the discharge energy check. A 1.4/50 attenuator is then used to attenuate this discharged energy. A photocoupler is used to monitor the output of the voltage attenuator. When the photocoupler detects the presence of the attenuated voltage, it outputs the continuity status to the CPU board.

The board is designed to withstand 50J discharge energy. However, the board can withstand 50J discharge energy for up to 15 continuous charging and discharging operations performed at a rate of 20 seconds per charging and discharging operation.

3-5 Pacing Switch Board (For TEC-7531 Only)

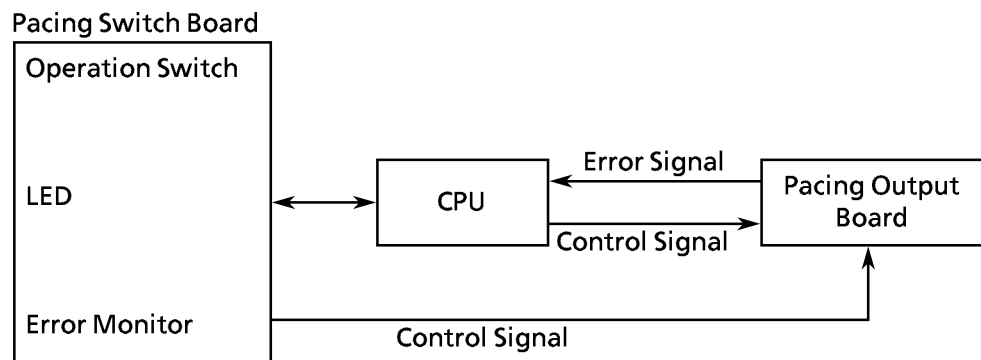

The Pacing Switch board provides the interface between the keys, knobs and lamps on the pacing block and the CPU board. The Pacing Switch board has also a monitoring circuit that monitors the instrument's pacing operation for abnormal pacing rate and abnormal pacing output current. When the monitoring circuit detects such abnormality, it blocks the output of the pacing timing signal to stop the pacing.

3-6 Pacing Output Board (For TEC-7531 Only)

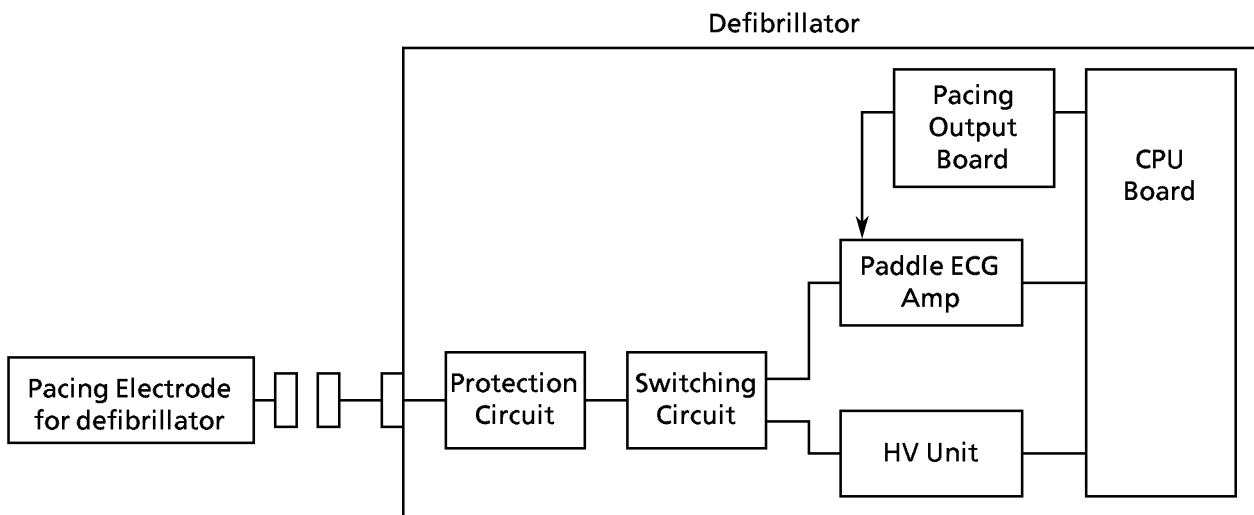

Patient Isolation

The Pacing Output board is connected to a patient-connected device, therefore, patient isolation must exist in this board. The high voltage isolation circuit is made up of a power transformer in the power supply, and photocouplers in the control and data signals.

When the Pacing On/Off key is pressed to start the pacing mode, the Pacing Switch board enables a signal to cause the Pacing On/Off lamp to light and the DC/DC converter to generate the 150 V power for the pacing pulse. If this signal is then disabled, the Pacing On/Off lamp goes off and any high voltage present in the circuit is immediately discharged internally.

DC/DC Converter

The DC/DC converter changes the 9 to 24 V it receives from the Mother board to 150 V for the pacing voltage. The Mother board provides the + 5 V needed to run the DC/DC converter.

Constant Current Drive

The constant current drive outputs the pacing pulse at its set constant current.

Waveform Generator

The waveform generator provides the pattern for the output current waveform as well as the setting of the waveform current.

Pacing Pulse Current Monitor

The pacing pulse current monitor compares the current of the output pacing pulse with the set value. If the current of the output pacing pulse is different than the set value, the pacing pulse current monitor outputs the error signal to the CPU board.

Photocouplers

The photocouplers provide the communication interface between the grounded circuits and the floating circuits for the control signals, such as the pacing on/off signal from the CPU board and the error signal from the error detection circuit.

Error Detection Circuit

The error detection circuit outputs the error signal to the CPU board when it detects a faulty pacing switch or an excessive high resistance in the output load that prevents the set constant current from flowing in the circuit.

Output Current Monitor

The output current monitor checks the output current in the pacing pulse for abnormality.

+ 5 V

The Mother board provides the + 5 V power to run the DC/DC converter.

± 6 V

The Mother board provides the ± 6 V power to run the analog circuits on the Pacing Output board.

3-7 HV Relay Unit

The HV relay unit is composed of the HV Drive board, HV relay unit, and step-up transformer.

Step-up Transformer

This step-up transformer is a DC/DC converter that provide the voltage which is required for various settings and to charge the high voltage capacitor.

HV Relays

There are two types of high voltage (HV) relays: the external relay and the internal relay. The external relay is responsible for opening and closing the connection of the ECG signal input circuit or pacing output circuit to the patient via the paddles, and the connection of the high voltage charging circuit to the high voltage capacitor. During ECG monitoring or pacing operation mode, the external relay closes the connection of the ECG signal input circuit or pacing output circuit to the patient via the paddle, and the connection of the high voltage charging circuit to the high voltage capacitor. This allows the instrument to pick up the ECG signal from the patient or to output the pacing signal to the patient. Also, if charging is activated, the high voltage charging circuit can charge the high voltage capacitor. During defibrillation, the external relay opens the connection of the ECG signal input circuit or pacing output circuit to the patient, and the high voltage charging circuit to the high voltage capacitor. However, in this situation, the connection of the high voltage capacitor to the patient is closed. This allows the high voltage capacitor to discharge its stored energy to the patient and prevents the ECG signal input circuit or pacing output circuit from high voltage input that can damage it.

The internal relay is used to disarm the capacitor when a fault is detected, the capacitor has been in charged condition for more than 40 seconds or when the rotary switch is set to "DISARM". In this situation, the internal relay closes the circuit to discharge the stored energy of the high voltage capacitor.

HV Drive Board

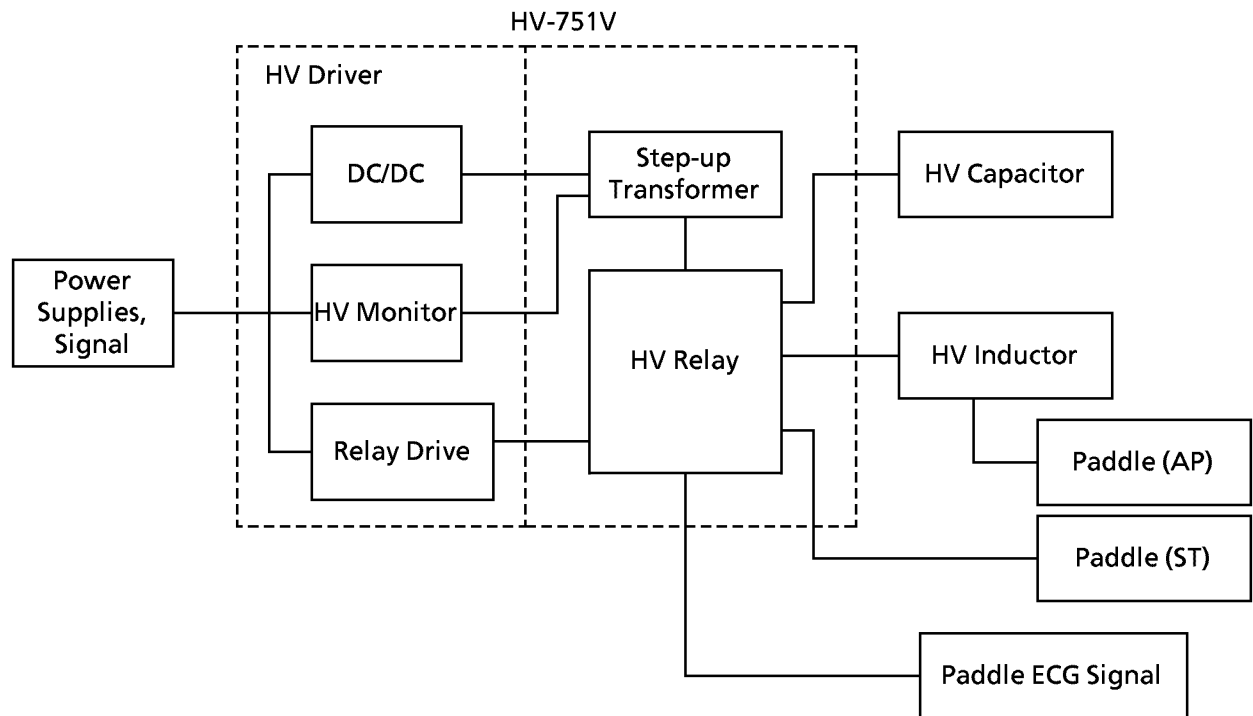

The HV Drive board has three functional blocks:

1. DC/DC Conversion Control Block

The DC/DC conversion control block provides the switching control for the high voltage step-up transformer. This block receives the start charging signal from the CPU board via the Mother board, and outputs the control signal to the switching FET that switches on or off the high voltage step-up transformer. This block also monitors the temperature of the switching FET and outputs the overheat signal to the CPU board when the switching FET gets too hot.

2. Voltage Monitoring Block

The voltage monitoring block monitors the voltage of the high voltage capacitor. It attenuates the voltage of the high voltage capacitor, and outputs the voltage reading to the CPU board via the Mother board. When there is a fault in this block, it outputs the fault signal to the CPU board.

3. High Voltage Relay Drive Block

The high voltage relay drive block controls the closing and opening of the high voltage external or internal relay. This block receives the driving signal from the CPU board via the Mother board. When there is a fault in the external relay drive block, it outputs the fault signal to the CPU board via the Mother board.

3-8 External Paddles

The external paddle is designed to accommodate the adult plate and child plate into one design. The sternum paddle has the Discharge button and the Paddle contact indicator (for ND-752V only). The apex paddle has the Charge button, Discharge button, and Charge lamp.

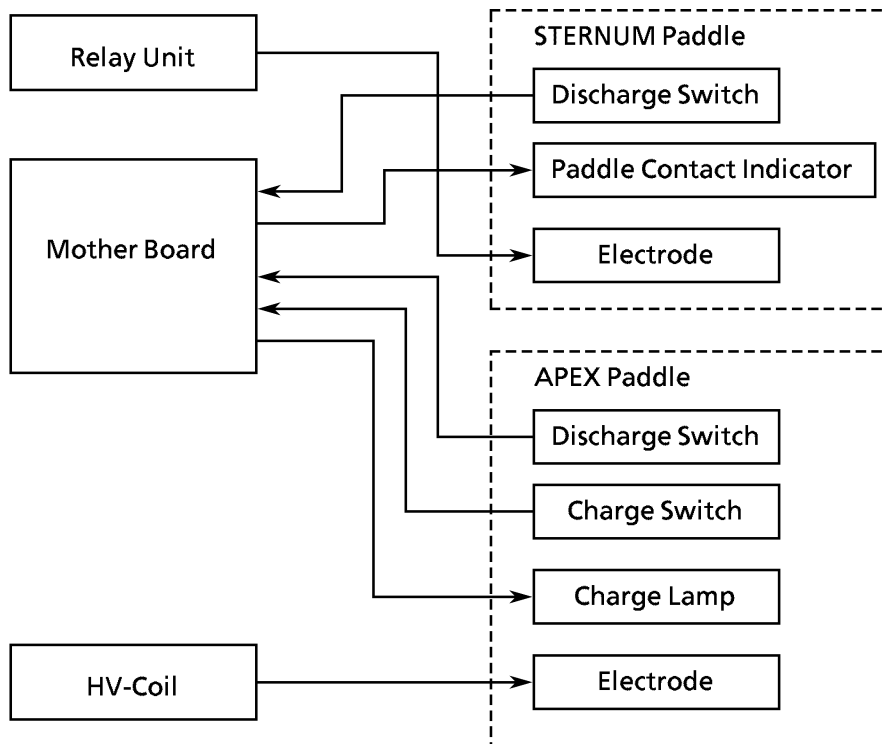

When the Charge button is pressed, it enables the signal that charges the high voltage capacitor. The CPU board then outputs the signal to the Mother board to light the paddle's charge lamp. To discharge the stored energy of the capacitor via the external paddles, both Discharge buttons on the paddles must be simultaneously pressed to enable the signal line that directs the output of the charged capacitor to the external paddles' electrodes.

When both Discharge buttons are not pressed, the paddles' electrodes pick up the patient's physiological signal. From this picked up signal, the CPU board can determine the electrode-to-skin contact resistance. The CPU board then outputs the control signal to the paddle contact indicator's driver on the Mother board.

3-9 Recorder Unit

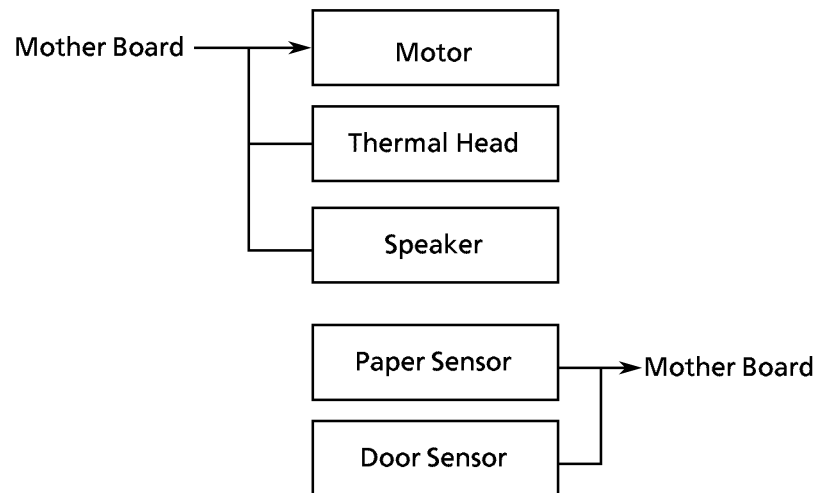

The recorder unit consists of the following components:

- motor
- thermal head
- speaker
- paper empty sensor
- door open/close sensor

The recorder unit receives the motor drive control signal from the CPU board via the Mother board. This motor drive control signal is used to drive the motor of the recorder unit. The recorder unit also receives the thermal head printing control signal from the CPU board via the Mother board. The thermal head printing control signal is used to turn on and off the thermal head for recording.

The speaker outputs the sound after it received the sound signal from the CPU board via the Mother board.

The recorder unit has one sensor that detects the presence or absence of recording paper in the instrument and another sensor that detects whether the magazine door is open or close. The status of these sensors is output to the Mother board.

3-10 ZR-I/F Unit (Optional)

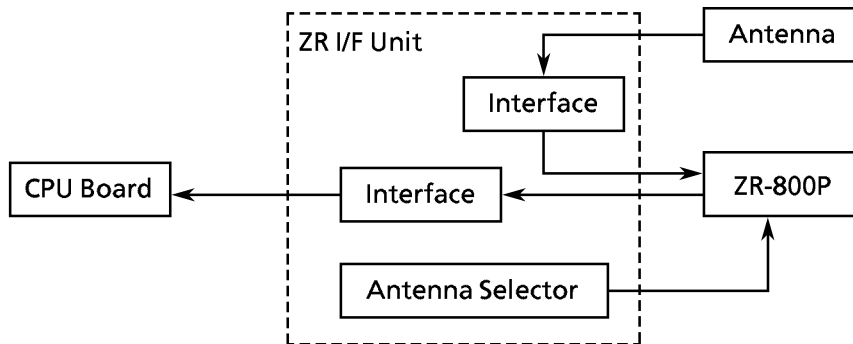

The ZR-I/F unit provides the interface for the ZR-800P receiver unit. The ZR-800P receiver unit receives and demodulates the telemetry signal from a compatible Nihon Kohden's patient transmitter. The demodulated signal is then output to the ZR-I/F unit for processing before it is input into the CPU board.

The antenna selector set the antenna setting of the ZR-800P receiver unit to diversity or antenna 1 setting.

The telemetry signal carries the ECG, pacing pulse, SpO₂, battery status, leads off status and nurse call data of the patient.

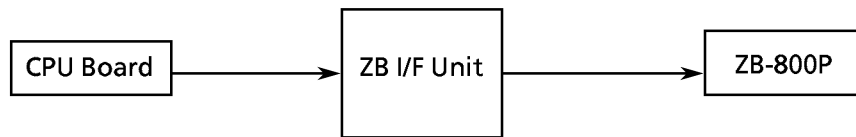
3-11 ZB I/F Unit (Optional)

The ZB I/F unit provides the interface for the ZB-800P transmitter. The CPU board outputs the transmission data to the ZB I/F unit. The ZB I/F unit processes the data and outputs the processed data to the ZB-800P transmitter unit. The ZB-800P then modulates the data and outputs the telemetry signal as radio frequency waves to a compatible Nihon Kohden bedside monitor or cardiac telemetry system.

The telemetry signal carries the ECG and leads off status data of the patient.

This page is intentionally left blank

Section 4 DISASSEMBLY AND ASSEMBLY

4-1	Before You Begin	4.1
4-2	Replacing the Battery	4.2
4-3	Removing the Top Case	4.3
4-4	Removing the Front Unit Assy	4.5
4-5	Replacing the Power Unit (AC/DC Unit)	4.7
4-6	Replacing the CPU Board	4.8
4-7	Replacing the Mother Board	4.9
4-8	Replacing the Paddles	4.10
4-9	Replacing the Paddles' Release Knob	4.11
4-10	Replacing the Recorder Unit	4.12
4-11	Replacing the CRT Unit	4.13
4-12	Cables Connections of the High Voltage Unit	4.15
4-13	Maintenance Schedule	4.16

The procedures in this section tell how to remove, replace and install major components in the instrument.

4-1 Before You Begin

Removing, replacing and installing major components should be done by qualified service personnel.

WARNING

To avoid the possibility of injury to yourself or damage to the instrument, do not install or remove any component or change switch settings while the power is on. If the instrument is in operation, switch it off. Disconnect the AC power cord from the instrument or/and remove the battery from battery compartment before opening and disassembling the instrument.

The HV capacitor can store lethal amounts of energy. Be sure to discharge this capacitor before touching high voltage components, such as the HV capacitor, HV inductor, relay unit, or paddles.

To avoid accidental discharge of static electricity, which could damage the instrument components, wear a grounded wrist strap when installing or removing any component of the instrument.

CAUTION

Fuses cut off the power when an abnormality occurs in the instrument. Eliminate the malfunction before replacing the fuse. Use the correct fuse only. The fuse rating is shown on the holder.

Required Tools

Anti-static bench mat
Anti-static wrist strap
Flat-blade screwdriver (insulated type)
Phillips screwdriver (insulated type)
Standard Hex (Allen) wrench or Hex keys
Tweezers
Nipper
Short bar

4-2 Replacing the Battery

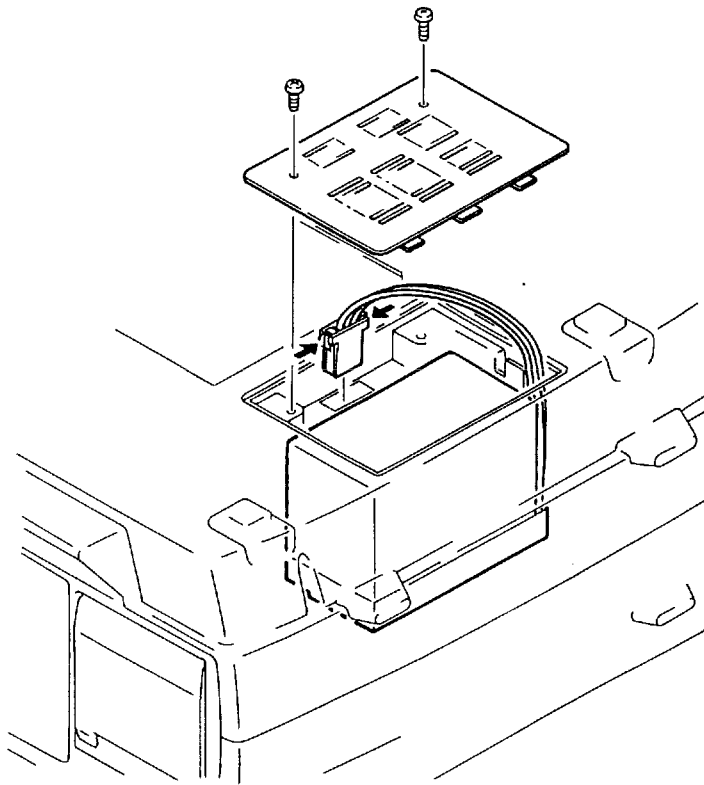

1. Place the instrument with its bottom up.
2. Remove the battery cover.
3. Disconnect the connector of the battery.
4. Remove the battery.

4-3 Removing the Top Case

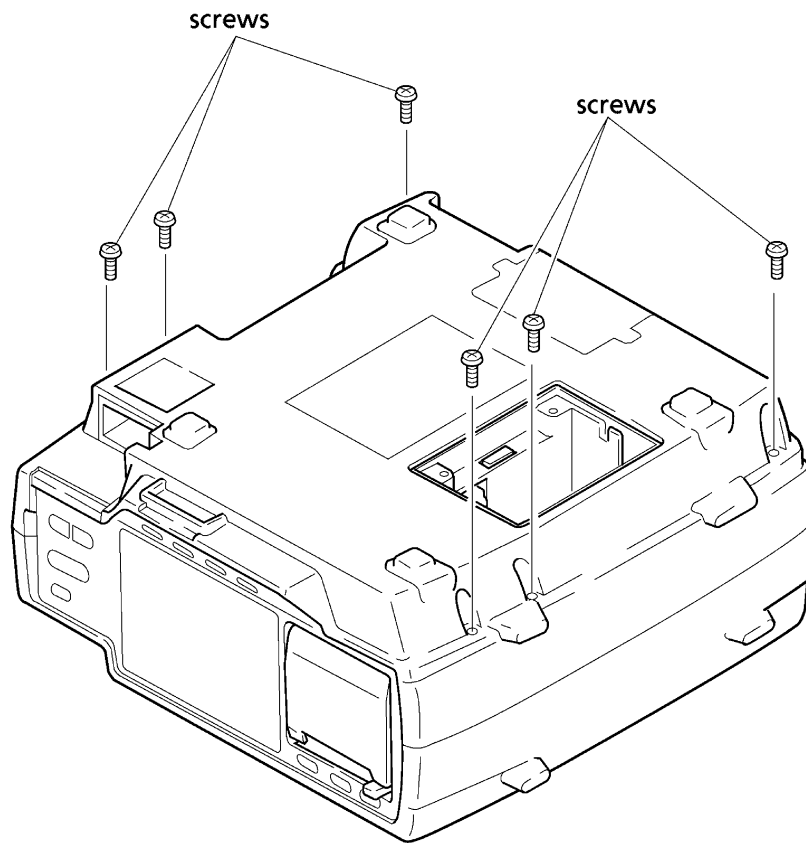

1. Remove the battery.
2. Disconnect and remove the paddles from the instrument. For TEC-7511, remove the paddles from their holders and place them on the instrument side.
3. Place the instrument with its bottom side facing up.
4. Unscrew the 6 screws to remove the top case to the bottom case.
5. Place the instrument with its top side facing up.

4. DISASSEMBLY AND ASSEMBLY

6. Slightly lift the top case from the bottom casing so that the connecting cables between the two cases can be disconnected.

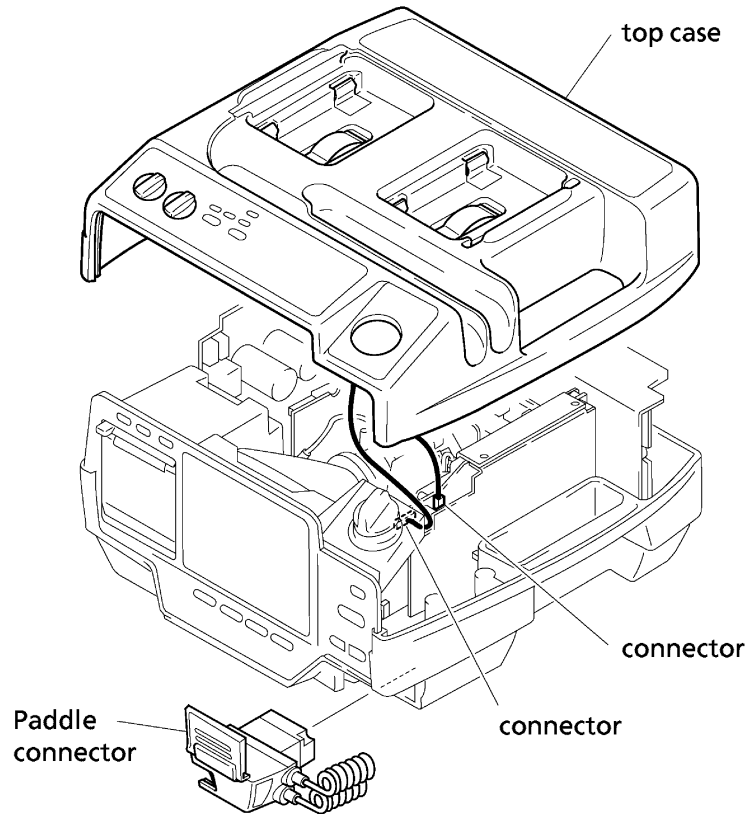

7. Disconnect the cable connecting the Test Load board and the CPU board. For TEC-7531, you have to disconnect another cable connecting the Pacing Switch board to the CPU board.

4-4 Removing the Front Unit Assy

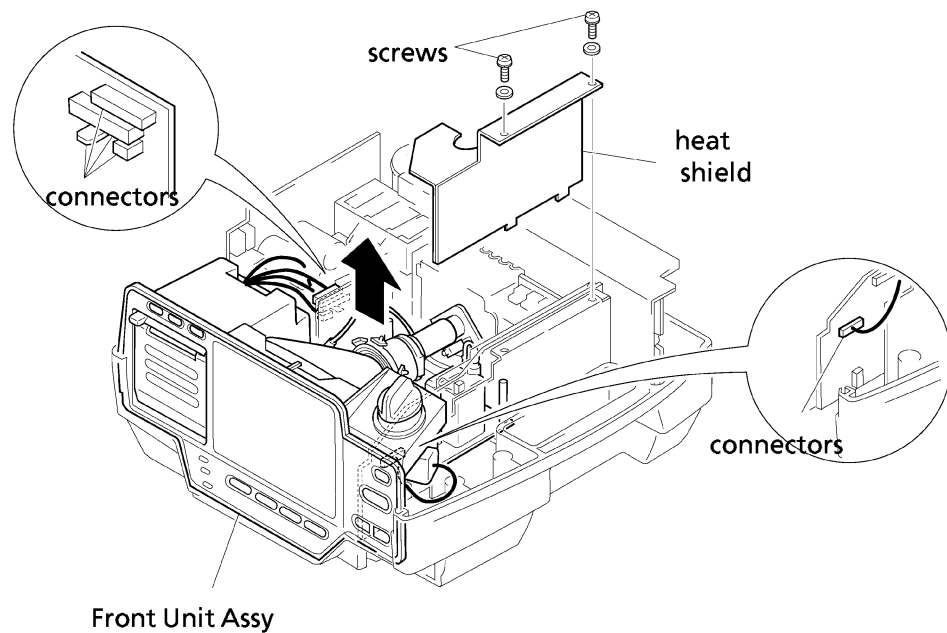

1. Remove the battery.
2. Remove the top case.
3. Unscrew the two screws to remove the CPU board heat shield from the instrument.
4. Disconnect the following cables:
 - a) cable connecting the Switch and LED board and the CPU board.
 - b) four cables connecting the recorder unit and the Mother board.

For TEC-7511, you have to remove the paddles from the instrument unscrewing the screw fastening the paddles to the instrument.

4. DISASSMBLY AND ASSEMBLY

5. Slightly lift up the front unit assy so that the connecting cable can be disconnected.

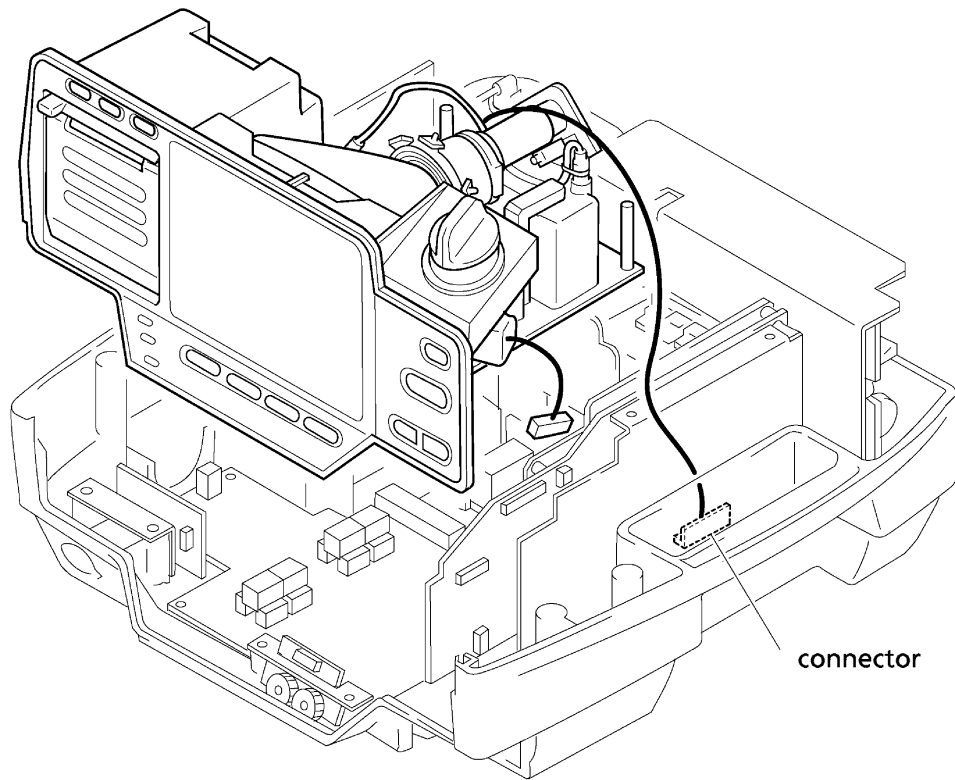

6. Disconnect the cable connecting the CRT unit to the Mother board.

4-5 Replacing the Power Unit (AC/DC Unit)

1. Remove the blank panel from the rear of the instrument.
2. Disconnect the connector from the Mother board.
3. Remove the top casing of the instrument.

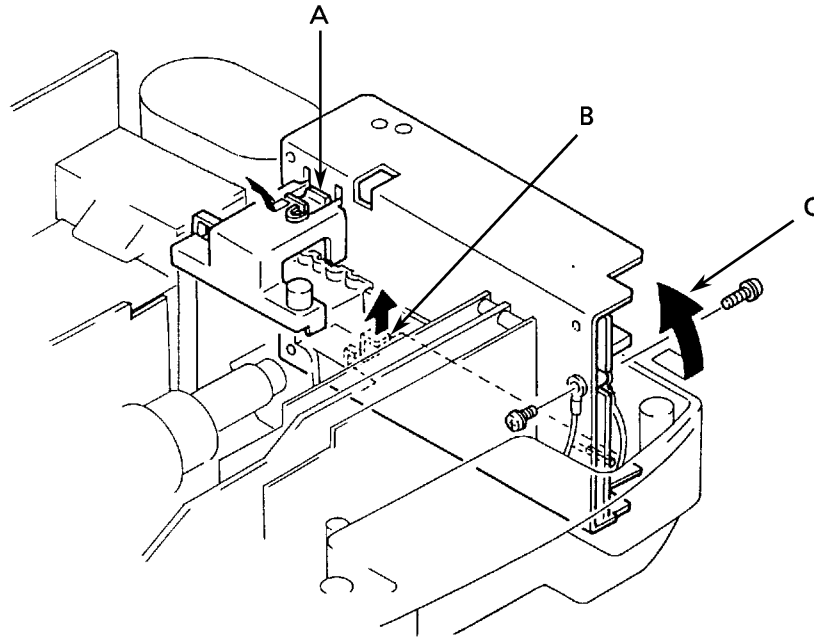

4. Disengage the HV relay holder lock A.
5. Disconnect the connector from the AC inlet.
6. Disconnect the ground cables C from the AC inlet bracket and the paddle connector.
7. Disengage the power unit holder lock B and remove the unit.

4-6 Replacing the CPU Board

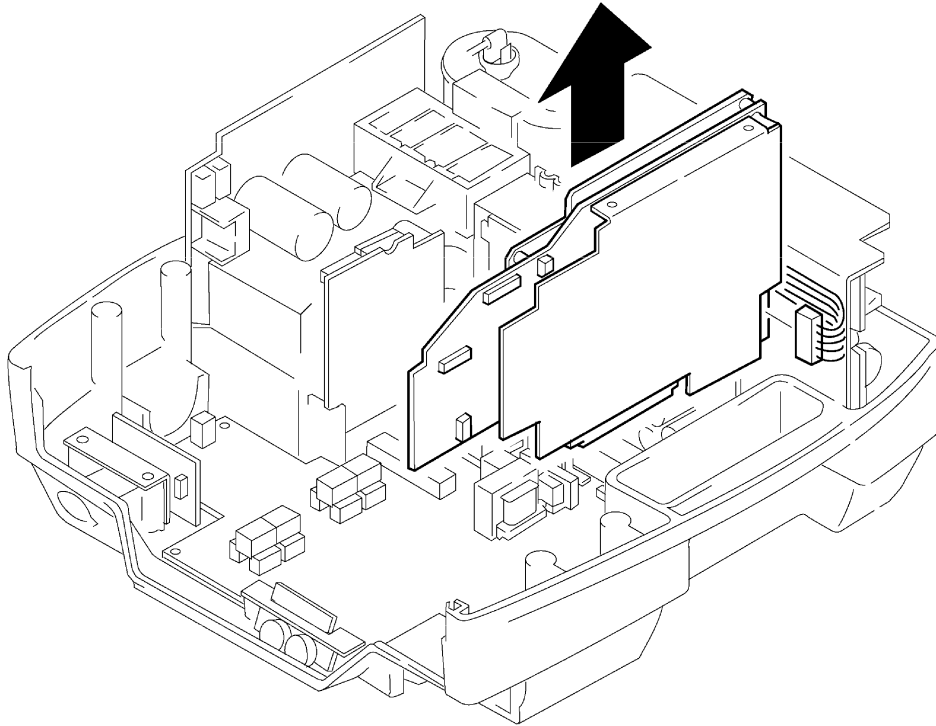

1. Remove the battery.
2. Remove the top case.
3. Remove the front unit assy.
4. Vertically lift the CPU board from the Mother board in bottom case. The connector connecting the two boards can be damaged if the CPU board is not lifted vertically from the Mother board.
5. Disconnect the cable connecting the CPU board and the optional unit.

4-7 Replacing the Mother Board

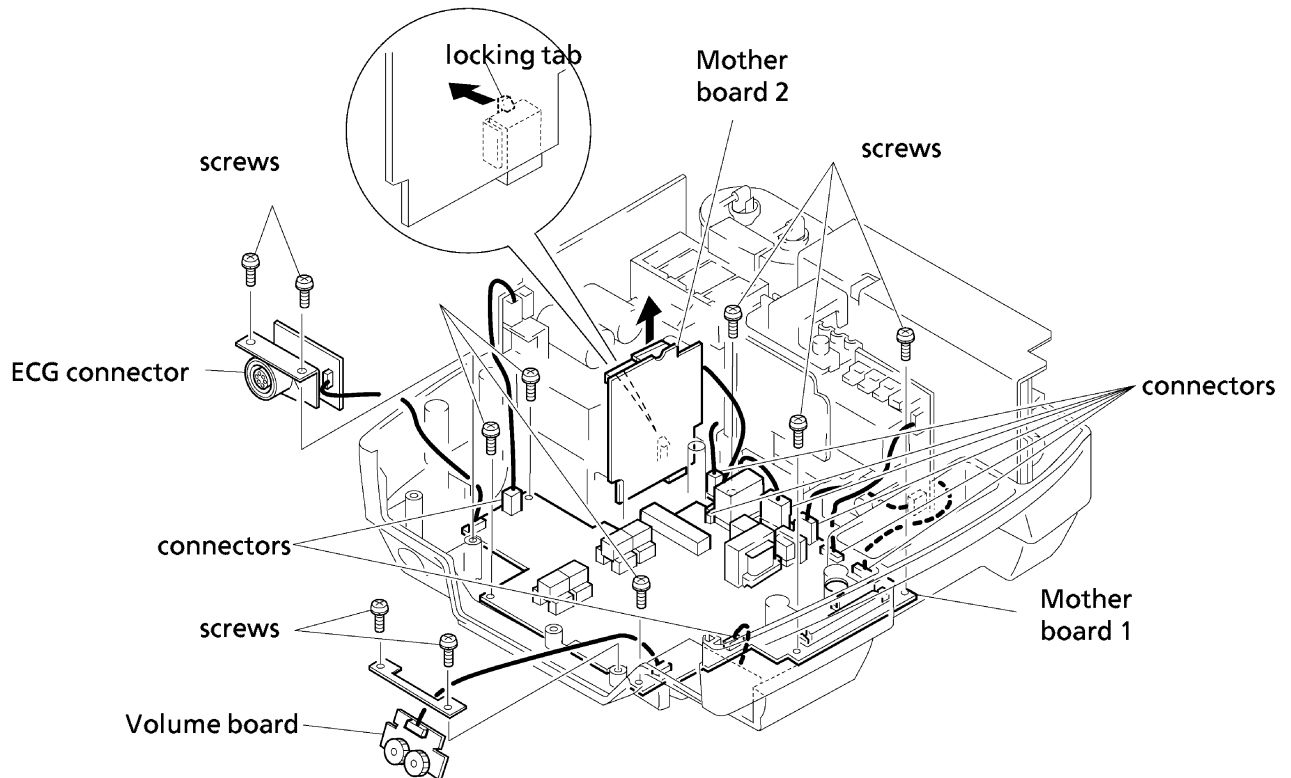

1. Remove the battery.
2. Remove the top case.
3. Remove the front unit assy.
4. Remove the CPU board.
5. Remove the ECG connector bracket.
6. Remove the Volume board holder.
7. Disconnect the following:
 - a) cable connecting Mother board 1 and Pacing Output board (For TEC-7351 only).
 - b) two cables connecting Mother board 1 and relay unit.
 - c) cable connecting Mother board 1 and AC/DC unit.
 - d) cable connecting Mother board 1 and HV inductor.
 - e) cable connecting Mother board 1 and paddle connector.
 - f) cable connecting Mother board 1 and the connecting part of the top of the battery compartment (for TEC-7511 and TEC-7521) or the Pacing Output board (For TEC-7351 only).
8. Bend the mother board holder tab to remove the Mother board 2 from bottom case.
9. Unscrew the six screws to remove Mother board 1 and 2, ECG connector board and Volume board from the bottom case.

4-8 Replacing the Paddles

1. Remove the top casing of the instrument.
2. Remove the CPU board.

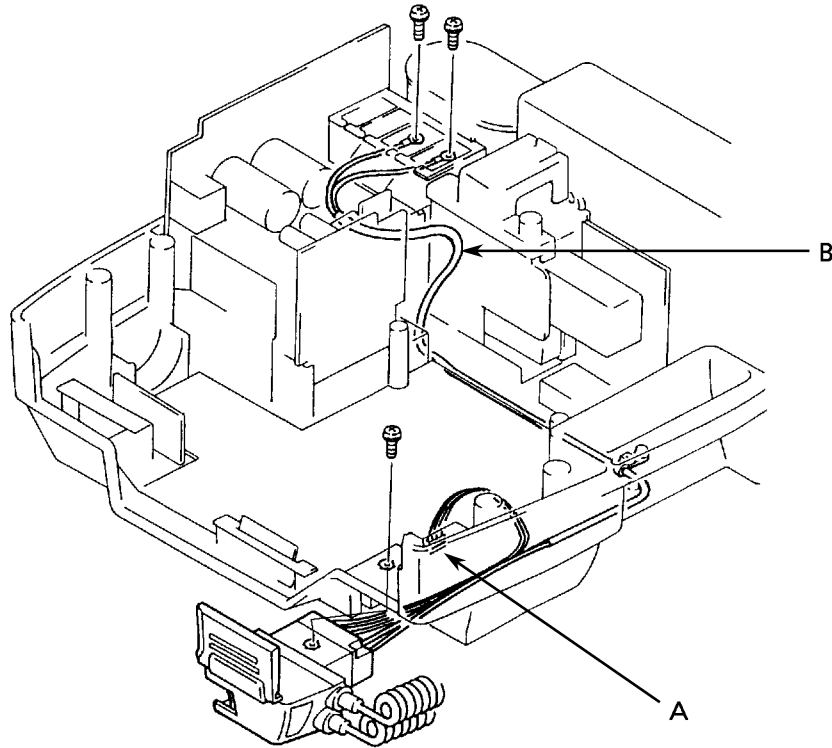

3. Disconnect connector A.
4. Remove the Mother board.
5. Disconnect high voltage cable B.
6. Remove the paddles from the instrument.

NOTE

The above illustration is for TEC-7511 where the paddle connector is fixed to the instrument by screws.

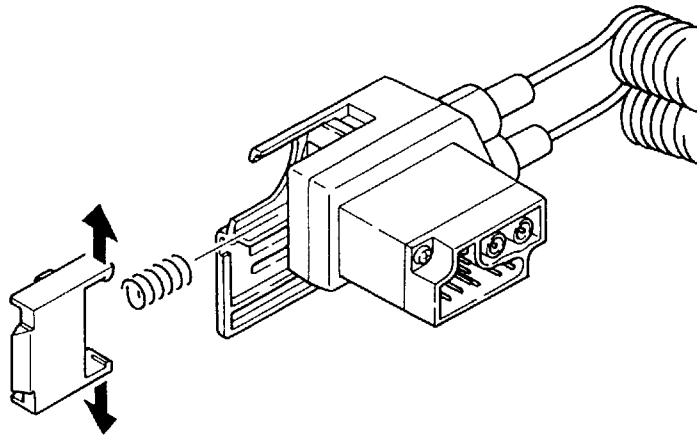
4-9 Replacing the Paddles' Release Knob

Remove the paddles' release knob from the paddle assemblies.

4-10 Replacing the Recorder Unit

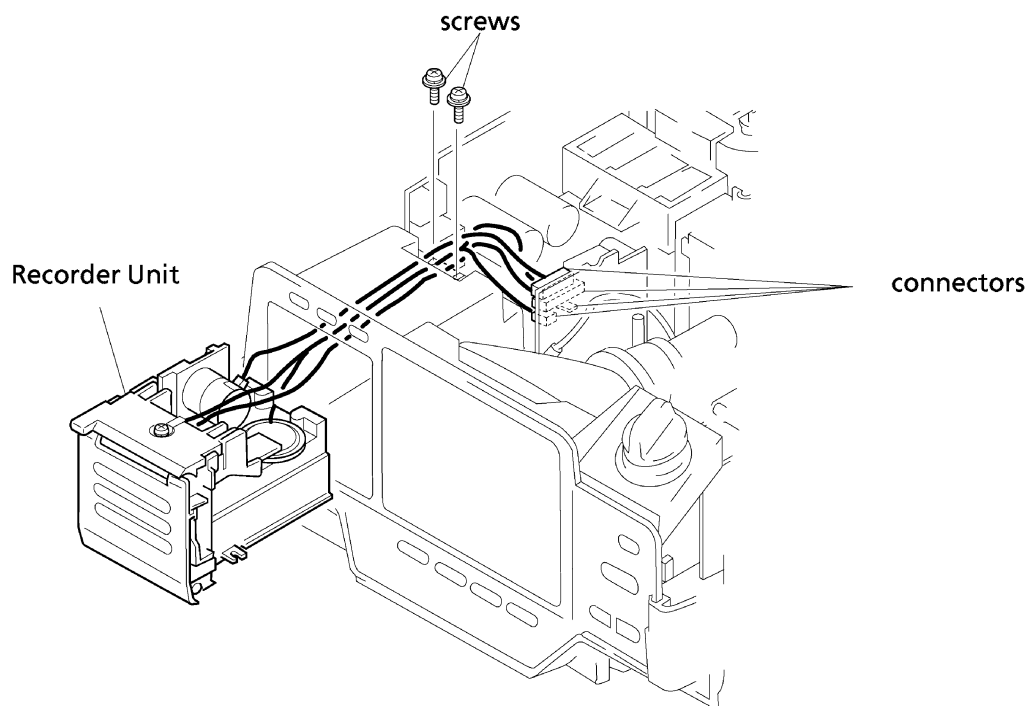

1. Remove the battery.
2. Remove the top case.
3. Unscrew the two screws to remove the recorder unit from the front panel.
4. Disconnect the four cables connecting the Mother board 2 and the recorder unit.

4-11 Replacing the CRT Unit

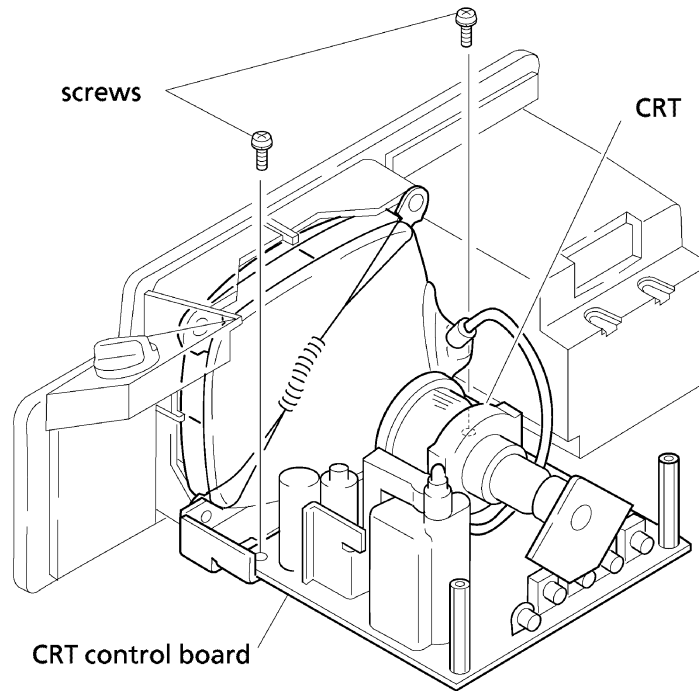

1. Remove the battery.
2. Remove the top case.
3. Remove the front unit assy.
4. Unscrew the two screws to remove the CRT control board from the front panel.

4. DISASSEMBLY AND ASSEMBLY

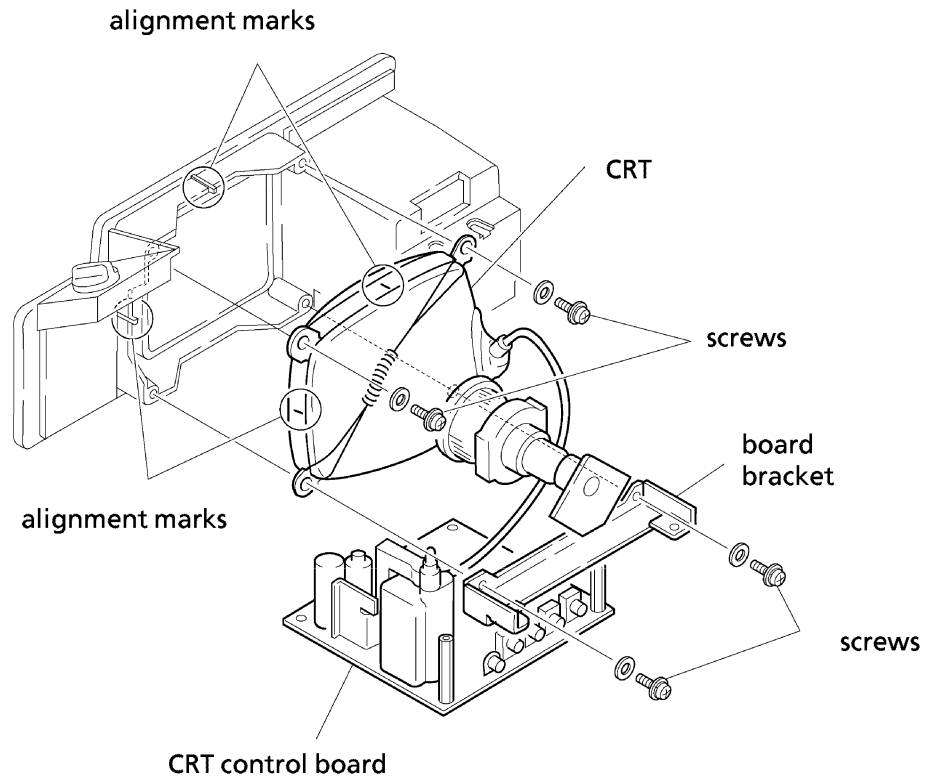

5. Unscrew the four screws to remove the CRT unit from the front panel.

NOTE

When re-installing the CRT unit, make sure the two alignment marks on the CRT unit are aligned to the two alignment marks on the front panel.

4-12 Cables Connections of the High Voltage Unit

The cables connections for the high voltage unit.

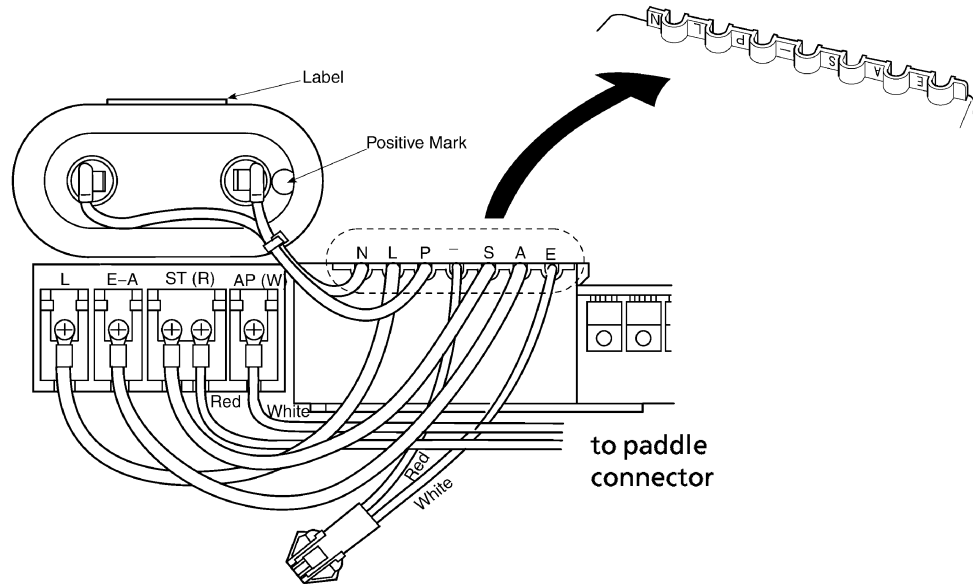

4-13 Maintenance Schedule

Battery LC-S2912NK 1 year.

Section 5 CHECKS, SETTINGS AND ADJUSTMENTS

5-1	Calling Up the System Maintenance Screen	5.1
5-2	Calling Up the System Maintenance Item	5.3
5-3	System Maintenance (A) Screen	5.4
5-4	System Maintenance (B) Screen	5.5
5-4-1	System Maintenance (B-1) Test Key Screen	5.6
5-4-2	System Maintenance (B-2) Test Lamp Screen	5.8
5-4-3	System Maintenance (B-3) Test CRT Screen	5.9
5-4-4	System Maintenance (B-4) CAL Wave Display Screen	5.10
5-5	System Maintenance (C) Menu Screen	5.12
5-5-1	System Maintenance (C-1) Adjust ECG Gain Screen	5.13
5-5-2	System Maintenance (C-2) Adjust Battery Voltage Screen	5.16
5-5-3	System Maintenance (C-3) Adjust HV Screen	5.18
5-5-4	System Maintenance (C-4) System Check Screen	5.23
5-5-5	Set Function: System Maintenance (C) Screen	5.24
5-5-6	Tele: System Maintenance (C) Screen	5.25
5-5-7	Alarm Off Message: System Maintenance (C) Screen	5.26
5-5-8	Language: System Maintenance (C) Screen	5.27
5-5-9	Charge Times Clear: System Maintenance (C) Screen	5.28
5-5-10	SRAM Clear: System Maintenance (C) Screen	5.29
5-5-11	EEPROM Save: System Maintenance (C) Screen	5.30
5-5-12	Debug (RS232C): System Maintenance (C) Screen	5.31
5-6	System Maintenance (D) Menu Screen	5.32
5-6-1	System Maintenance (D-1) A/D Value Screen	5.34

Required Tools

- Energy Checker (AX-102V or Impulse 3000 by Dynatech)
- Oscilloscope
- Signal generator
- 12 V 3 A power supply
- Battery voltage adjustment jig (NK Part No. 532595)

5-1 Calling Up the System Maintenance Screen

CAUTIONS

- The instrument cannot perform ECG monitoring and defibrillation when the System Maintenance screen is called up. You have to turn off and then turn on the instrument to return it to its normal function.
- You have to perform the EEPROM Save procedure in System Maintenance (C) screen after changing or adjusting any item in the System Maintenance screen. The new setting or adjustment is not stored in the EEPROM if the EEPROM Save procedure is not performed.
- When a fault is detected when the instrument is in the System Maintenance screen mode, the error code of the fault is displayed on the upper-right corner of this screen.

1. Turn the ENERGY/MODE SELECT control to the OFF position.
2. Press and hold down the alarm suspend key and turn the ENERGY/MODE SELECT control to the MON position.

When the System Setup (A) screen appears, release the alarm suspend key.

SYSTEM SETUP (A)			
1. UNIT NO.	XXXXX		
2. ALARM LIMITS	LATEST	DEFAULT	
3. POWER ON LEAD	PADDLE	II TELE	
4. ECG LEADS	3 LEADS	5 LEADS	
5. MODE AFTER CV	SYNC	DEFIB	
6. TELEMETRY			
ITEM	↓	↑	NEXT

5. CHECK, SETTINGS AND ADJUSTMENTS

3. Press and hold down the Setup key.
4. While pressing the Setup key, press the following keys, one at a time, in this sequence: ECG Lead key, Alarm suspend key, Sensitivity key.
5. Release the Setup key. The System Maintenance screen appears.

<System Maintenance Screen Example>

SYSTEM MAINTENANCE			
A VERSION			
B CHECK KEY, LAMP, CRT, CAL			
C ADJUST/SET			
D VIEW			
ITEM		EXEC	

To exit from the System Maintenance screen, turn off the instrument and then turn it on to return to normal operation.

5-2 Calling Up the System Maintenance Item

The System Maintenance screen has the following four sub-screens:

- System Maintenance (A)
- System Maintenance (B)
- System Maintenance (C)
- System Maintenance (D)

1. In the System Maintenance screen, press the [Item] key to select the item. The item number of the selected item is highlighted.
2. When the item is selected, press the [Exec] key to call up the menu screen of the selected item.

5-3 System Maintenance (A) Screen

<System Maintenance (A) screen example >

SYSTEM MAINTENANCE (A)	
1. ROM Ver.	Ver. XX-XX
2. SOFT Ver. (AP)	Ver. XX.XX
3. SOFT Ver. (DRV)	Ver. XX.XX
4. SOFT Ver. (PACING)	Ver. XX-XX
5. OS Ver.	Ver. X. X. X
EXIT	

The System Maintenance (A) screen shows the following version numbers:

- i) ROM Version
The version number of the ROM used in the instrument.
- ii) AP Version
The version number of the application (AP) software used by the instrument.
- iii) DRV Version
The version number of the device driver used by the instrument.
- iv) OS Version
The version number of the operating system (OS) used by the instrument.

To return to the System Maintenance screen, press the [Exit] key.

To print the information displayed on the System Maintenance screen, press and hold down the Record key until the recorder starts to print out the information.

5-4 System Maintenance (B) Screen

<System Maintenance (B) screen example >

SYSTEM MAINTENANCE (B)			
1.	TEST KEY	EXEC	OFF
2.	TEST LAMP	EXEC	OFF
3.	TEST CRT	EXEC	OFF
4.	CAL WAVE DISPLAY	EXEC	OFF
ITEM		←	→
		EXIT	

The System Maintenance (B) screen is the menu screen for the following tests and display screen:

- i) Test Key
- ii) Test Lamp
- iii) Test CRT
- iv) CAL Wave Display

1. In the System Maintenance (B) screen, press the [Item] key to select the item. The item number of the selected item is highlighted.

5. CHECK, SETTINGS AND ADJUSTMENTS

- When the item is selected, press the [←] or [→] key to select the status of the selected item. Each item has either EXEC status meaning that the item is executable, or OFF status meaning that the item is disabled. The selected status is highlighted. When EXEC is highlighted, the key names on the bottom of the screen are changed as follows.

EXEC	PASS		
------	------	--	--

- To execute the test on the selected test item, press the [Exec] key.
- To quit the test before it is executed, press the [Pass] key.
- To exit the System Maintenance (B) screen, press the [Exit] key. The System Maintenance screen appears.

5-4-1 System Maintenance (B-1) Test Key Screen

<System Maintenance (B-1) Test Key screen example >

SYSTEM MAINTENANCE (B) (B-1) TEST KEY			
	ROT1	ROT2	PAPER EXIST
			EXT PADDLE
			LEAD SENS
MON	200	40 170	SYNC ALARM
0	300	50 180	RECORD
2	360	60	REPORT
3		70	EVENT
5		80	PANEL-CHG
7		90	PADDLE-CHG
10		100	PANEL-DCHGR
20		110	PANEL-DCHGL
30		120	PADDLE-DCHGR
50		130	PADDLE-DCHGL
70		140	PACING-START
100		150	PACING-MODE
150		160	SET-UP
			EXIT

The System Maintenance (B-1) Test Key screen is used to check the functions of the rotary switches, keys, paddle, paper and magazine release sensors of the instrument. This screen displays the status of rotary switches, keys, paddle, paper and magazine release sensors of the instrument by highlighting the part names.

Part Name	Description
ROT1: from MON to 360	This shows the status of the Energy/Mode control rotary switch.
ROT2 from 40 to 180	This shows the status pacing rate control rotary switch.
PAPER EMPTY or PAPER EXIST	The "Paper Empty" message is displayed when there is no recording paper in the magazine or the magazine door is opened. The "Paper Exist" message is displayed if there is recording paper in the magazine and the magazine door is closed.
NOTHING PDL, EXT PADDLE, INT PADDLE, or DISPO. PDL	The "NOTHING PDL" message is displayed when the paddles are removed from the paddle holders. The "EXT PADDLE" message is displayed when external paddles are used. The "INT PADDLE" message is displayed when internal paddles are used. The "DISPO. PDL" message is displayed when disposable paddles paddles are used.
LEAD	This shows the status of the ECG Lead key.
SENS	This shows the status of the ECG sensitivity key.
SYNC	This shows the status of the SYNC key.
ALARM	This shows the status of the Alarm suspend key.
RECORD	This shows the status of the Record key.
REPORT	This shows the status of the Report key.
EVENT	This shows the status of the Event key.
PANEL-CHG	This shows the status of the panel's Charge key.
PADDLE-CHG	This shows the status of the paddle's Charge key.
PANEL-DCHGR	This shows the status of the panel's Discharge right key.
PANEL-DCHGL	This shows the status of the panel's Discharge left key.
PADDLE-DCHGR	This shows the status of the right paddle's Discharge key.
PADDLE-DCHGL	This shows the status of the left paddle's Discharge key.
PACING-START	This shows the status of the Pacing On/Off key.
PACING-MODE	This shows the status of the Fixed/demand key.
SET-UP	This shows the status of the Setup key.

To exit the System Maintenance (B-1) Test Key screen, press the [Exit] key. The System Maintenance (B) screen appears.

5-4-2 System Maintenance (B-2) Test Lamp Screen

<System Maintenance (B-2) Test Lamp screen example >

SYSTEM MAINTENANCE (B) (B-2) TEST LAMP			
1. SYNC ON			
2. EVENT			
3. RECORD			
4. REPORT			
5. PADDLE CONTACT GOOD			
6. PADDLE CONTACT MIDDLE			
7. PADDLE CONTACT BAD			
8. PADDLE CHARGE			
9. PACING MODE			
10. PACING START/STOP			
11. PACING PULSE			
12. PACING FIX			
13. PACING DEMAND			
ITEM	ON		EXIT

The System Maintenance (B-2) Test Lamp screen is used to check the lamps on the instrument.

To select the lamp on the instrument, press the [Item] key.

To turn on the selected lamp, press the [On] key.

To exit the System Maintenance (B-2) Test Lamp screen, press the [Exit] key.

5-4-4 System Maintenance (B-4) CAL Wave Display Screen

<System Maintenance (B-4) CAL Wave Display screen example>

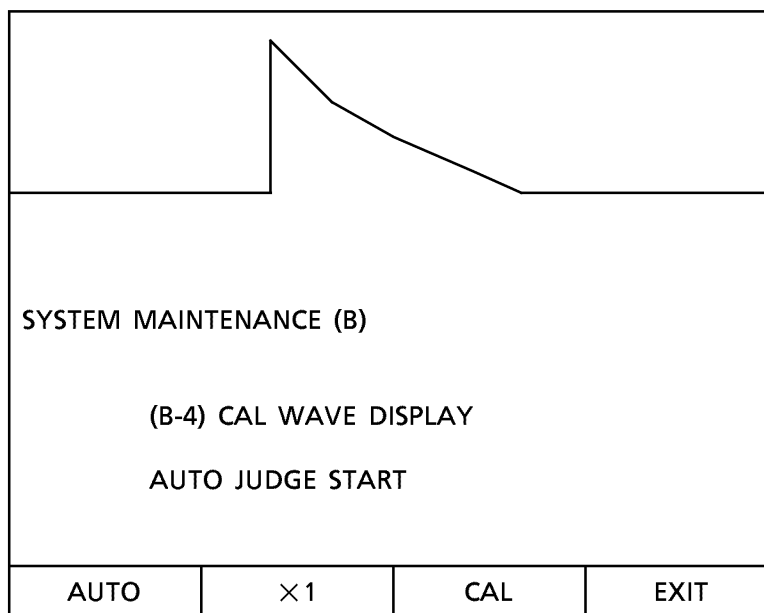

The System Maintenance (B-4) CAL Wave Display screen is used to display the CAL wave of the instrument. This screen has two modes: automatic mode and manual mode.

In automatic mode, the CAL wave of the selected sensitivity is displayed and printed.

In manual mode, the CAL wave of the selected sensitivity can be displayed and printed by pressing a few keys.

Procedure for Automatic Mode

1. Press the ECG sensitivity key until the required sensitivity key name is displayed at the bottom of the screen.
2. Press the [Auto] key. The screen displays the CAL wave and then the recorder automatically prints the result of the calibration.
3. Press the Exit key to exit the System Maintenance (B-4) CAL Wave Display screen.

Procedure for Manual Mode

1. Press the ECG sensitivity key until the required sensitivity key name is displayed at the bottom of the screen.
2. Press the Record key. The record lamps blinks during the recording.
3. Press the [CAL] key. The CAL wave appears.
4. Press the Record key again to stop the recording.
5. Press the Exit key to exit the System Maintenance (B-4) CAL Wave Display screen.

5-5 System Maintenance (C) Menu Screen

<System Maintenance (C) Menu screen example >

SYSTEM MAINTENANCE (C)			
1. ADJUST ECG GAIN	EXEC		OFF
2. ADJUST BATT VOL	EXEC		OFF
3. ADJUST HV	EXEC		OFF
4. SYSTEM CHECK	EXEC		OFF
5. SET FUNCTION	TYPE-1		
6. TELE (ZR)	DOMES	EXPORT	
7. ALARM OFF MESSAGE	ON		
8. LANGUAGE	ENGLISH A		
9. CHARGE TIMES CLEAR	EXEC		OFF
10. SRAM CLEAR	EXEC		OFF
11. EEPROM SAVE	EXEC		OFF
12. DEBUG (RS232C)	EXEC		OFF
ITEM	←	→	EXIT

The System Maintenance (C) menu screen displays the following adjustment and setting items of the instrument.

1. Adjust ECG Gain
2. Adjust Batt Vol
3. Adjust HV
4. System Check
5. Set Function
6. Tele (ZR)
7. Alarm Off Message
8. Language
9. Charge Times Clear
10. SRAM Clear
11. EEPROM
12. Debug (RS232C)

To print the adjustment and setting values of the System Maintenance (C) screen, press and hold down the Record key until the recorder starts to print out the information.

1. In the System Maintenance (C) menu screen, press the [Item] key to select the item. The item number of the selected item is highlighted.
2. When the item is selected, press the [←] or [→] key to select the status of the selected item. Each item has either EXEC status meaning that the item is executable, or OFF status meaning that the item is disabled. The selected status is highlighted.

When EXEC is highlighted, the key names on the bottom of the screen are changed as follows.

EXEC	PASS		
------	------	--	--

3. To execute the test on the selected test item, press the [Exec] key.
4. To quit the test before it is executed, press the [Pass] key.
5. To exit the System Maintenance (C) screen, press the [Exit] key. The System Maintenance screen appears.

5-5-1 System Maintenance (C-1) Adjust ECG Gain Screen

<System Maintenance (C-1) Adjust ECG Gain screen example >

			
SYSTEM MAINTENANCE (C) (C-1) ADJUST ECG GAIN			
1. AUTO SET		15	
2. MANUAL			
3. END			
ITEM		EXEC	

The System Maintenance (C-1) Adjust ECG Gain screen is used to adjust the ECG gain of the instrument. This adjustment can be performed in automatic mode or manual mode. To perform this adjustment, a sine wave generator is required to input a 2mV p-p 10 Hz sine wave into the instrument.

The default ECG gain value is 15.

CAUTION

Calling up the Adjust ECG gain screen automatically sets the ECG gain value to 15. Re-set the ECG gain value to its original value after calling up this screen.

Procedure for Automatic Mode

1. Connect the LL/F lead of the ECG leads to the + terminal of the sine wave generator and the RA/R and LA/L lead of the ECG leads to the – terminal of the sine wave generator.
2. Input a 2mV p-p 10 Hz sine wave into the instrument.
3. In the System Maintenance (C-1) Adjust ECG Gain screen, press the [Item] key to select item 1 (Auto Set).
4. Press the [Exec] key. The instrument automatically performs the ECG gain adjustment and displays the adjusted ECG gain value. In the automatic mode, the instrument repeats the ECG gain adjustment every 200 ms. The [Exec] key name is changes to [Stop].

You can print the wave on this screen by pressing the Record key and stop the printing by pressing the Record key again.

5. To quit the automatic mode ECG gain adjustment, press the [Stop] key. The “ECG Adjust End” message is displayed on the screen.
6. To exit the System Maintenance (C-1) Adjust ECG Gain screen, press the [Item] key to select item 3 (End) and then press the [Exit] key.

5-5-2 System Maintenance (C-2) Adjust Battery Voltage Screen

<System Maintenance (C-2) Adjust Battery Voltage screen example>

SYSTEM MAINTENANCE (C)			
(C-2) ADJUST BATTERY VOLTAGE			
BATTERY VOLTAGE XX. XXV			
1. AUTO + 1			
ADJUST BATTERY A/D END			
2. MANUAL			
3. END			
ITEM		EXEC	

The System Maintenance (C-2) Adjust Battery Voltage screen displays the battery voltage and is also used to adjust the battery A/D converter gain at a battery voltage of 11.5 V. The adjustment can be performed in automatic mode or manual mode.

The default value of the battery A/D converter gain is 0.

Procedure in Automatic Mode

1. Remove the battery from the battery compartment.
2. Connect the connector end of the battery voltage adjustment jig (NK Part No. 532595) to the battery input connect of the instrument and the "banana" type clip end to the DC voltage generator.
3. In the System Maintenance (C-2) Adjust Battery Voltage screen, press the [Item] key to select item 1 (Auto Set).
4. Set the output voltage of the DC voltage generator to 11.5 V.
5. Press the [Exec] key. The instrument automatically performs the battery A/D converter gain adjustment and displays the adjusted battery A/D converter gain value. In the automatic mode, the instrument repeats the battery A/D converter gain adjustment every 200 ms. The [Exec] key name is changed to [Stop].
6. To quit the automatic mode battery A/D converter gain adjustment, press the [Stop] key. The "Adjust Battery A/D End" message is displayed on the screen.

7. To exit the System Maintenance (C-2) Adjust Battery Voltage screen, press the [Item] key to select item 3 (End) and then press the [Exit] key.

Procedure for Manual Mode

1. In the System Maintenance (C-2) Adjust Battery Voltage Gain screen, press the [Item] key to select item 2 (Manual). The key names on the bottom of the screen change when item 2 is selected.

<System Maintenance (C-2) Adjust Battery Voltage screen example >

SYSTEM MAINTENANCE (C)			
(C-2) ADJUST BATTERY VOLTAGE			
BATTERY VOLTAGE XX. XXV			
1. AUTO + 1			
2. MANUAL			
3. END			
ITEM	↓	↑	

2. Press the [↓] and [↑] keys to adjust the battery A/D converter gain value. The range of this adjustment is from - 25 to + 25.
3. To quit the manual mode battery A/D converter gain adjustment, press the [Item] key to select item 3 (End).
4. To exit the System Maintenance (C-2) Adjust Battery Voltage Gain screen, press the [Exit] key.

5-5-3 System Maintenance (C-3) Adjust HV Screen

<System Maintenance (C-3) Adjust HV screen example for TEC-7521 and TEC-7531 >

SYSTEM MAINTENANCE (C)			
(C-3) ADJUST HV			
1.	CHARGE MODE (XXX J)	XXXJ	
	CHARGING		
2.	CHARGE A/D VOLUME	+ 1	
3.	TTR VOLUME	XXX Ω	- 1
4.	DELIVERED ENERGY	XXX J	0
5.	CHARGE TIME		0.00 sec
6.	END		
ITEM			

<System Maintenance (C-3) Adjust HV screen example for TEC-7511 >

SYSTEM MAINTENANCE (C)			
(C-3) ADJUST HV			
1.	CHARGE MODE (XXX J)	XXXJ	
	CHARGING		
2.	CHARGE A/D VOLUME	+ 1	
3.	XXXXXXXXXX		
4.	XXXXXXXXXX		
5.	CHARGE TIME		0.00 sec
6.	END		
ITEM			

The System Maintenance (C-3) Adjust HV screen is used to display and set the defibrillation settings of the instrument. This screen has the following items:

1. Charge mode
2. Charge A/D Volume
3. TTR Volume
4. Delivered Energy
5. Charge Time

To select the item in the System Maintenance (C-3) Adjust HV screen, press the [Item] key until the required item is highlighted.

To exit the System Maintenance (C-3) Adjust HV screen, press the [Item] key until item 6 (End) is highlighted and then press the [Exit] key. The [Exit] key appears only when item 6 (End) is selected.

Procedure to Display Defibrillation Settings

1. Make sure the external paddles are properly inserted in their holders.
2. In the System Maintenance (C-3) Adjust HV screen, select the defibrillation energy by turning the Energy/Mode select control of the instrument. The selected defibrillation energy is displayed in brackets next to item 1 (Charge Mode).
3. Press the Charge button on the apex paddle. The “Charging” message appears below item 1. After the charging is completed, the “Charging” message changes to “Charged” and the length of time for charging to complete is displayed next to item 5 (Charge Time). If an error occurs during charging, an error message is displayed.
4. After the “Charged” message appears, press both the Discharge buttons on the paddles to discharge the charged energy into the paddle holders. The TTR volume (item 3) and the delivered energy (item 4) values are displayed in this screen.

5. CHECK, SETTINGS AND ADJUSTMENTS

Procedure to Set the Charge A/D Volume

1. In the System Maintenance (C-3) Adjust HV screen, press the [Item] key to select item 2 (Charge A/D Volume).
2. Press the [↓] or [↑] key to set the Charge A/D volume to the required setting. The range of this setting is from -25 to +25. The default setting is 0.

<System Maintenance (C-3) Adjust HV screen example >

SYSTEM MAINTENANCE (C)			
(C-3) ADJUST HV			
1. CHARGE MODE (XXX J)			XXXJ
2. CHARGE A/D VOLUME			+ 1
3. TTR VOLUME	XXX Ω		- 1
4. DELIVERED ENERGY	XXX J		0
5. CHARGE TIME			0.00 sec
6. END			
ITEM	↓	↑	

Procedure to Set the TTR Volume

1. In the System Maintenance (C-3) Adjust HV screen, press the [Item] key to select item 3 (TTR Volume).
2. Press the [↓] or [↑] key to set the TTR volume to the required setting. The range of this setting is from - 25 to + 25. The default setting is 0.

<System Maintenance (C-3) Adjust HV screen example >

SYSTEM MAINTENANCE (C)			
(C-3) ADJUST HV			
1. CHARGE MODE (XXX J)	XXXJ		
2. CHARGE A/D VOLUME	+ 1		
3 TTR VOLUME	XXX Ω	- 1	
4. DELIVERED ENERGY	XXX J	0	
5. CHARGE TIME		0.00 sec	
6. END			
ITEM	↓	↑	

5. CHECK, SETTINGS AND ADJUSTMENTS

Procedure to Set the Delivered Energy

1. In the System Maintenance (C-3) Adjust HV screen, press the [Item] key to select item 4 (Delivered Energy).
2. Press the [↓] or [↑] key to set the delivered energy to the required setting. The range of this setting is from - 25 to + 25.

<System Maintenance (C-3) Adjust HV screen example >

SYSTEM MAINTENANCE (C)			
(C-3) ADJUST HV			
1. CHARGE MODE (XXX J)			XXXJ
2. CHARGE A/D VOLUME			+ 1
3. TTR VOLUME	XXX Ω		- 1
4. DELIVERED ENERGY	XXX J		0
5. CHARGE TIME			0.00 sec
6. END			
ITEM	↓	↑	

Procedure to Show the Charge Time

1. In the System Maintenance (C-3) Adjust HV screen, press the [Item] key to select item number 5 (Charge Time).
2. Press the Charge button on the apex paddle. The time on the right of the item number 5 (Charge Time) shows the charging time. This time is updated every 200 ms until the charging has completed. The final charging time is displayed to the nearest 20ms.

NOTE

In this selection, the charged energy is automatically discharged internally a few seconds after the charging has completed. Pressing the Discharge buttons on both the paddles does not discharge the charged energy externally because the Discharge buttons are disabled when the item 5 (Charge Time) is selected.

5-5-4 System Maintenance (C-4) System Check Screen

<System Maintenance (C-4) System Check screen example >

SYSTEM MAINTENANCE (C)			
(C-4) SYSTEM CHECK			
1. CHECK SUM		XXXX OK (XXXX)	
2. RAM READ/WRITE CHK		EXECUTING	
	80%	CHECKED	
EXEC	PASS		

The System Maintenance (C-4) System Check screen is used to check the ROM and RAM of the instrument. The ROM is checked by using a check sum check program and RAM is checked using a read and write check program. These check programs automatically start when the System Check item is selected in the System Maintenance menu screen. During the check, the percentage of completion is displayed on the screen.

The result of the check is displayed next to the check item, an "OK" message is displayed when no error is detected and an "NG" message together with its faulty memory location is displayed if an error is detected.

5-5-5 Set Function: System Maintenance (C) Screen

<System Maintenance (C) Menu screen example >

SYSTEM MAINTENANCE (C)			
1. ADJUST ECG GAIN	EXEC		<input type="checkbox"/> OFF
2. ADJUST BATT VOL	EXEC		<input type="checkbox"/> OFF
3. ADJUST HV	EXEC		<input type="checkbox"/> OFF
4. SYSTEM CHECK	EXEC		<input type="checkbox"/> OFF
5. SET FUNCTION	TYPE-1		
6. TELE (ZR)	<input checked="" type="checkbox"/> DOMES	EXPORT	
7. ALARM OFF MESSAGE	ON		
8. LANGUAGE	ENGLISH A		
9. CHARGE TIMES CLEAR	EXEC		<input type="checkbox"/> OFF
10. SRAM CLEAR	EXEC		<input type="checkbox"/> OFF
11. EEPROM SAVE	EXEC		<input type="checkbox"/> OFF
12. DEBUG (RS232C)	EXEC		<input type="checkbox"/> OFF
ITEM	←	→	EXIT

This item in the System Maintenance (C) menu screen is used to set the instrument type. The instrument type is described in the table below.

	Type-1	Type-2	Type-3
Model	TEC-7511	TEC-7521	TEC-7531

To select the instrument type in the System Maintenance (C) menu screen, press the [Item] key to select item 5 (Set Function) and then press the [←] or [→] key to select your instrument type.

5-5-6 Tele: System Maintenance (C) Screen

<System Maintenance (C) Menu screen example>

SYSTEM MAINTENANCE (C)			
1. ADJUST ECG GAIN	EXEC		OFF
2. ADJUST BATT VOL	EXEC		OFF
3. ADJUST HV	EXEC		OFF
4. SYSTEM CHECK	EXEC		OFF
5. SET FUNCTION	TYPE-1		
6. TELE (ZR)	DOMES		EXPORT
7. ALARM OFF MESSAGE	ON		
8. LANGUAGE	ENGLISH A		
9. CHARGE TIMES CLEAR	EXEC		OFF
10. SRAM CLEAR	EXEC		OFF
11. EEPROM SAVE	EXEC		OFF
12. DEBUG (RS232C)	EXEC		OFF
ITEM	←	→	EXIT

Item 6 in the System Maintenance (C) menu screen is used to set the telemetry type of the instrument. There are two telemetry types available for the instrument: Japan (DOMES) and international (EXPORT). The default setting is export.

To select the telemetry type in the System Maintenance (C) menu screen, press the [Item] key to select item 6 (Tele) and then press the [←] or [→] key to select the required telemetry type.

5-5-7 Alarm Off Message: System Maintenance (C) Screen

<System Maintenance (C) Menu screen example >

SYSTEM MAINTENANCE (C)			
1. ADJUST ECG GAIN	EXEC		<input type="checkbox"/> OFF
2. ADJUST BATT VOL	EXEC		<input type="checkbox"/> OFF
3. ADJUST HV	EXEC		<input type="checkbox"/> OFF
4. SYSTEM CHECK	EXEC		<input type="checkbox"/> OFF
5. SET FUNCTION	TYPE-1		
6. TELE (ZR)	<input checked="" type="checkbox"/> DOMES	EXPORT	
7. ALARM OFF MESSAGE	ON		
8. LANGUAGE	ENGLISH A		
9. CHARGE TIMES CLEAR	EXEC		<input type="checkbox"/> OFF
10. SRAM CLEAR	EXEC		<input type="checkbox"/> OFF
11. EEPROM SAVE	EXEC		<input type="checkbox"/> OFF
12. DEBUG (RS232C)	EXEC		<input type="checkbox"/> OFF
ITEM	ON	OFF	EXIT

This item in the System Maintenance (C) menu screen is used to turn the alarm off message on the screen on or off. When this setting is On, the “Alarm Off” message is displayed on the screen when the alarm is turned off. If this setting is Off, the “Alarm Off” message is not displayed on the screen when the alarm is turned off.

To set the alarm off message in the System Maintenance (C) menu screen, press the [Item] key to select item 7 (Alarm Off Message) and then press the [On] or [Off] key to select the required setting.

5-5-8 Language: System Maintenance (C) Screen

<System Maintenance (C) Menu screen example>

SYSTEM MAINTENANCE (C)			
1. ADJUST ECG GAIN	EXEC		OFF
2. ADJUST BATT VOL	EXEC		OFF
3. ADJUST HV	EXEC		OFF
4. SYSTEM CHECK	EXEC		OFF
5. SET FUNCTION	TYPE-1		
6. TELE (ZR)	DOMES	EXPORT	
7. ALARM OFF MESSAGE	ON		
8. LANGUAGE	ENGLISH A		
9. CHARGE TIMES CLEAR	EXEC		OFF
10. SRAM CLEAR	EXEC		OFF
11. EEPROM SAVE	EXEC		OFF
12. DEBUG (RS232C)	EXEC		OFF
ITEM	←	→	EXIT

This item in the System Maintenance (C) menu screen is used to set the language used in the instrument. The instrument has seven language settings: English A (for suffix A model numbers version), English K (for suffix K model numbers version), German, French, Italian, Spanish, and Japanese. The default language setting of the instrument is set at the factory for the country the instrument is exported to.

NOTE

When English A setting is selected, the default setting for Date Format is "MMM/DD/YY" and the default setting for Mode After CV (Cardioversion) is "DEFIB".
When English K setting is selected, the default setting for Date Format is "DD/MMM/YY" and the default setting for Mode After CV (Cardioversion) is "SYNC".

To change the language setting in the System Maintenance (C) menu screen, press the [Item] key to select item 8 (Language) and then press the [←] or [→] key to select the required language setting.

5-5-9 Charge Times Clear: System Maintenance (C) Screen

<System Maintenance (C) Menu screen example >

SYSTEM MAINTENANCE (C)			
1. ADJUST ECG GAIN	EXEC		OFF
2. ADJUST BATT VOL	EXEC		OFF
3. ADJUST HV	EXEC		OFF
4. SYSTEM CHECK	EXEC		OFF
5. SET FUNCTION	TYPE-1		
6. TELE (ZR)	DOMES	EXPORT	
7. ALARM OFF MESSAGE	ON		
8. LANGUAGE	ENGLISH A		
9. CHARGE TIMES CLEAR	EXEC		OFF
10. SRAM CLEAR	EXEC		OFF
11. EEPROM SAVE	EXEC		OFF
12. DEBUG (RS232C)	EXEC		OFF
ITEM	←	→	EXIT

This item in the System Maintenance (C) menu screen is used to reset the charge times counter to 0. The instrument keeps a record of the number of times that charging is performed by the instrument. This record, known as the count times, is cleared when this item is changed.

Procedure to Clear the Charge Times

1. In the System Maintenance (C) menu screen, press the [Item] key to select item 9 (Clear Charge Times).
2. Press the [←] or [→] key to change the status of the selected item to “Exec”. When EXEC is highlighted, the key names on the bottom of the screen are changed as follows.

EXEC	PASS		
------	------	--	--

3. To clear the charge times, press the [Exec] key.
4. To quit without clearing the charge times, press the [Pass] key.

5-5-10 SRAM Clear: System Maintenance (C) Screen

<System Maintenance (C) Menu screen example>

SYSTEM MAINTENANCE (C)			
1. ADJUST ECG GAIN	EXEC		OFF
2. ADJUST BATT VOL	EXEC		OFF
3. ADJUST HV	EXEC		OFF
4. SYSTEM CHECK	EXEC		OFF
5. SET FUNCTION	TYPE-1		
6. TELE (ZR)	DOMES	EXPORT	
7. ALARM OFF MESSAGE	ON		
8. LANGUAGE	ENGLISH A		
9. CHARGE TIMES CLEAR	EXEC		OFF
10. SRAM CLEAR	EXEC		OFF
11. EEPROM SAVE	EXEC		OFF
12. DEBUG (RS232C)	EXEC		OFF
ITEM	←	→	EXIT

This item in the System Maintenance (C) menu screen is used to clear the data stored in the SRAM.

Procedure to Clear the SRAM

1. In the System Maintenance (C) menu screen, press the [Item] key to select item 10 (SRAM Clear).
2. Press the [←] or [→] key to change the status of the selected item to “Exec”. When EXEC is highlighted, the key names on the bottom of the screen are changed as follows.

EXEC	PASS		
------	------	--	--

3. To clear the SRAM, press the [Exec] key.
4. To quit without clearing the SRAM data, press the [Pass] key.

5-5-11 EEPROM Save: System Maintenance (C) Screen

<System Maintenance (C) Menu screen example >

SYSTEM MAINTENANCE (C)			
1. ADJUST ECG GAIN	EXEC		OFF
2. ADJUST BATT VOL	EXEC		OFF
3. ADJUST HV	EXEC		OFF
4. SYSTEM CHECK	EXEC		OFF
5. SET FUNCTION	TYPE-1		
6. TELE (ZR)	DOMES	EXPORT	
7. ALARM OFF MESSAGE	ON		
8. LANGUAGE	ENGLISH A		
9. CHARGE TIMES CLEAR	EXEC		OFF
10. SRAM CLEAR	EXEC		OFF
11. EEPROM SAVE	EXEC		OFF
12. DEBUG (RS232C)	EXEC		OFF
ITEM	←	→	EXIT

This item in the System Maintenance (C) menu screen is used to save the settings data of the System Maintenance (C) menu screen into the EEPROM of the instrument.

Procedure to Save Setting Data into EEPROM

1. In the System Maintenance (C) menu screen, press the [Item] key to select item 11 (EEPROM Save).
2. Press the [←] or [→] key to change the status of the selected item to “Exec”. When EXEC is highlighted, the key names on the bottom of the screen are changed as follows.

EXEC	PASS		
------	------	--	--

3. To save the settings data into the EEPROM, press the [Exec] key.
4. To quit without saving, press the [Pass] key.

5-5-12 Debug (RS232C): System Maintenance (C) Screen

<System Maintenance (C) Menu screen example>

SYSTEM MAINTENANCE (C)			
1. ADJUST ECG GAIN	EXEC		OFF
2. ADJUST BATT VOL	EXEC		OFF
3. ADJUST HV	EXEC		OFF
4. SYSTEM CHECK	EXEC		OFF
5. SET FUNCTION	TYPE-1		
6. TELE (ZR)	DOMES	EXPORT	
7. ALARM OFF MESSAGE	ON		
8. LANGUAGE	ENGLISH A		
9. CHARGE TIMES CLEAR	EXEC		OFF
10. SRAM CLEAR	EXEC		OFF
11. EEPROM SAVE	EXEC		OFF
12. DEBUG (RS232C)	EXEC		OFF
ITEM	←	→	EXIT

This item in the System Maintenance (C) menu screen is used during the debugging of the instrument. This is only used in the factory during production. The default setting of this item is Off.

5-6 System Maintenance (D) Menu Screen

<System Maintenance (D) Menu screen example >

SYSTEM MAINTENANCE (D)			
1	CHECK A/D	EXEC	OFF
2.	CHARGE TIMES		
	2J-200J		3
	300J-360J		4
3.	OPERATION TIME	XXXXXX h.	XXm
	←	→	EXIT

The System Maintenance (D) menu screen displays the following information:

1. Check A/D
2. Charge Times
3. Operation Time

The charge times has two parameters: the number of times the instrument is charged at energy range 2J to 200J and at 300J to 360J.

The operation time is the total length of time, displayed to the nearest minute that the instrument has been used since shipment from the factory. The maximum operation time that can be displayed by this instrument is 99,999 hours and 59 minutes. This operation time function can be disabled using the System Maintenance screen of the system setup.

To print this information, press and hold down the Record key until the recorder starts to print out the information.

1. In the System Maintenance (D) menu screen, press the [Item] key to select the item. The item number of the selected item is highlighted.

- When the item is selected, press the [←] or [→] key to select the status of the selected item. Each item has either EXEC status meaning that the item is executable, or OFF status meaning that the item is disabled. The selected status is highlighted. When EXEC is highlighted, the key names on the bottom of the screen are changed as follows.

EXEC	PASS		
------	------	--	--

- To execute the test on the selected test item, press the [Exec] key.
- To quit the test before it is executed, press the [Pass] key.
- To exit the System Maintenance (D) screen, press the [Exit] key. The System Maintenance screen appears.

5-6-1 System Maintenance (D-1) A/D Value Screen

<System Maintenance (D-1) A/D Value screen example >

SYSTEM MAINTENANCE (D)	
(D-1) A/D VALUE	
	DATA ADJUST
1. ECG WAVE	XXXX XX
2. CHARGE VOLTAGE	XXX - XX
3. TTR	XXX 0
4. BATTERY VOLTAGE	XXX + XX
5. PADDLE POLARIZATION	XXX
6. RECORDER HEAD TEMP.	XXX
7. BATTERY TEMP.	XXX
8. RSSI	XXX
9. EP CURRENT VOLTAGE	XXX
10. HV MONITOR ERROR	XXX
11. HV EXT ERROR	XXX
12. BATTERY VOLTAGE	XX. XXV
	EXIT

The System Maintenance (D-1) A/D Value screen displays A/D values (decimal, ranging from 0 to 1023) of the following data:

1. ECG Wave
2. Charge Voltage
3. TTR
4. Battery Voltage
5. Paddle Polarization
6. Recorder Head Temperature
7. Battery Temperature
8. Radio Frequency Signal Strength Intensity (RSSI)
9. EP Current Voltage
10. Charge Voltage (SFC)
11. External Relay Voltage (SFC)
12. Battery Voltage

These A/D values are revised every 200 ms. ECG wave, charge voltage, TTR and battery voltage can be adjusted using this screen.

To exit the System Maintenance (D-1) A/D Value screen, press the [Exit] key. The System Maintenance (D) menu screen appears.

System Maintenance Screen Default Settings

Menu A Screen

1. ROM Version	Ver. ____-____
2. Software Version (AP)	Ver. ____.
3. Software Version (DRV)	Ver. ____.
4. Software Version (PACING)	Ver. ____-____
5. OS Version	Ver. __. __. __

Menu B Screen

1. TEST KEY	OFF
2. TEST LAMP	OFF
3. TEST CRT	OFF
4. CAL WAVE DISPLAY	OFF

Menu C Screen

1. ADJUST ECG GAIN	OFF
2. ADJUST BATT VOL	OFF
3. ADJUST HV	OFF
4. SYSTEM CHECK	OFF
5. SET FUNCTION	_____
6. TELE (ZR)	_____
7. ALARM OFF DISPLAY	ON
8. LANGUAGE	_____
9. CHARGE TIMES CLEAR	OFF
10. SRAM CLEAR	OFF
11. EEPROM CLEAR	OFF
12. EEPROM SAVE	OFF
13. DEBUG (RS232C)	OFF

Menu D Screen

1. CHECK A/D	OFF
2. CHARGE TIMES	
2J to 200J	X
300J to 360J	X
3. OPERATION TIME	XXXXXh. XXm

NOTES

- The software version number depends on the instrument itself and may change from instrument to instrument.
- The Set Function, Tele (ZR), and Language settings in menu C screen depend on the model and installed option of the instrument and also the country the instrument is exported to.
- The values displayed in the Charge times and Operation time, represented as X in the above table, are not constant.

This page is intentionally left blank

Section 6 REPLACEABLE PARTS LIST

6-1	Main Unit Parts	6.2
6-2	ND-752V External Paddle Parts	6.8
6-3	QI-751V Transmitter Interface Unit Parts	6.10
6-4	ZR-751V Telemetry Receiver Parts	6.12
6-5	ZA-003P Antenna and Antenna Mount Parts	6.14
6-6	KD-001A Cart Parts	6.16

When ordering parts or accessories from your nearest Nihon Kohden Corporation distributor, please quote the NK part number and part name which is listed in this service manual, and the name or model of the unit in which the required part is located. This will help us to promptly attend to your needs. Always use parts and accessories recommended or supplied by Nihon Kohden Corporation to assure maximum performance from your instrument.

6-1 Main Unit Parts

No.	NK Part No.	Description	
101	YZ-004H8	TEC-7500 Pace current knob Assy	TEC-7500 Paceキョウドツマミ Assy
102	YZ-004H7	TEC-7500 Pace rate knob Assy	TEC-7500 Pace rate ツマミ Assy
103	6123-008432A	Pacing panel (for TEC-7531A/K)	ペーシングソウサパネル(K)(ロット)
	6122-003635	Pacing panel (for TEC-7531C)	ペーシングソウサパネル(C)(ロット)
	6122-003804	Pacing panel (for TEC-7531E)	ペーシングソウサパネル(E)(ロット)
	6122-003911	Pacing panel (for TEC-7531F)	ペーシングソウサパネル(F)(ロット)
	6122-003555	Pacing panel (for TEC-7531G)	ペーシングソウサパネル(G)(ロット)
	6123-009485	Pacing panel (for TEC-7531R)	ペーシングソウサパネル(R)(ロット)
	6123-008183B	Pacing blank panel (for TEC-7511, TEC-7521)	ペーシングブランクパネル (TEC-7511/7521)
104	6122-003118A	Operation label (for TEC-7531A/K)	トリセツパネル(K)(ロット)
	6122-003608	Operation label (for TEC-7531C)	トリセツパネル(C)(ロット)
	6122-003796	Operation label (for TEC-7531E)	トリセツパネル(E)(ロット)
	6122-003902	Operation label (for TEC-7531F)	トリセツパネル(F)(ロット)
	6122-003546A	Operation label (for TEC-7531G)	トリセツパネル(G)(ロット)
	6122-003573	Operation label (for TEC-7531R)	トリセツパネル(R)(ロット)
105	6123-008361B	Energy/Mode select label (for TEC-7511A/K, TEC-7521A/K)	ロータリSWパネル(ロット)
	6123-009583	Energy/Mode select label (for TEC-7511C, TEC-7521C)	ロータリSWパネル(C)(ロット)
	6123-010135	Energy/Mode select label (for TEC-7511E, TEC-7521E)	ロータリSWパネル(E)(ロット)
	6123-010269	Energy/Mode select label (for TEC-7511F, TEC-7521F)	ロータリSWパネル(F)(ロット)
	6123-009458	Energy/Mode select label (for TEC-7511G, TEC-7521G)	ロータリSWパネルG(ロット)
	6123-009502	Energy/Mode select label (for TEC-7511R, TEC-7521R)	ロータリSWパネル(R)(ロット)
	6123-008379B	Energy/Mode select label (for TEC-7531A/K)	ロータリSWパネルP(エイ)(ロット)
	6123-009574	Energy/Mode select label (for TEC-7531C)	ロータリSWパネルP(C)(ロット)
	6123-010126	Energy/Mode select label (for TEC-7531E)	ロータリSWパネルP(E)(ロット)
	6123-010251	Energy/Mode select label (for TEC-7531F)	ロータリSWパネルP(F)(ロット)
	6123-009449A	Energy/Mode select label (for TEC-7531G)	ロータリSWパネルPG(ロット)
	6123-009494	Energy/Mode select label (for TEC-7531R)	ロータリSWパネルP(R)(ロット)
106	6124-026794	TEC-7511A Model label	TEC-7511Aカタメイラベル
	6124-027133	TEC-7511C Model label	TEC-7511Cカタメイラベル
	6124-027801	TEC-7511E Model label	TEC-7511Eカタメイラベル
	6124-028248	TEC-7511F Model label	TEC-7511Fカタメイラベル
	6124-026642	TEC-7511G Model label	TEC-7511Gカタメイラベル
	6124-024591	TEC-7511K Model label	TEC-7511Kカタメイラベル
	6124-026909	TEC-7511R Model label	TEC-7511Rカタメイラベル

No.	NK Part No.	Description	
106	6124-026802	TEC-7521A Model label	TEC-7521Aカタメイラベル
	6124-027124	TEC-7521C Model label	TEC-7521Cカタメイラベル
	6124-027793	TEC-7521E Model label	TEC-7521Eカタメイラベル
	6124-028239	TEC-7521F Model label	TEC-7521Fカタメイラベル
	6124-026633	TEC-7521G Model label	TEC-7521Gカタメイラベル
	6124-024582	TEC-7521K Model label	TEC-7521Kカタメイラベル
	6124-026892	TEC-7521R Model label	TEC-7521Rカタメイラベル
	6124-026811	TEC-7531A Model label	TEC-7531Aカタメイラベル
	6124-027115	TEC-7531C Model label	TEC-7531Cカタメイラベル
	6124-027784	TEC-7531E Model label	TEC-7531Eカタメイラベル
	6124-028221	TEC-7531F Model label	TEC-7531Fカタメイラベル
	6124-026624	TEC-7531G Model label	TEC-7531Gカタメイラベル
	6124-024314	TEC-7531K Model label	TEC-7531Kカタメイラベル
	6124-026883	TEC-7531R Model label	TEC-7531Rカタメイラベル
107	1114-173801A	Test load electrode	テストロードデンキヨク
108	1114-199899	Spacer bolt L40M4	カンカクボルトL40M4
109	6111-002238D	Top casing.1	ジヨウブケース.1
110	6114-035802A	Paddle lock packing	パドルロックパツキン
111	6114-069677A	Paddle lock spring K-718	パドルロックバネK-718
112	6114-073048	Waterproof sheet	ボウスイシート(ジヨウブーシン)
B	US-0148	Pacing Switch ROM Board	ペーシングSW ROM
C	UR-0147	Test Load Board	テストロード

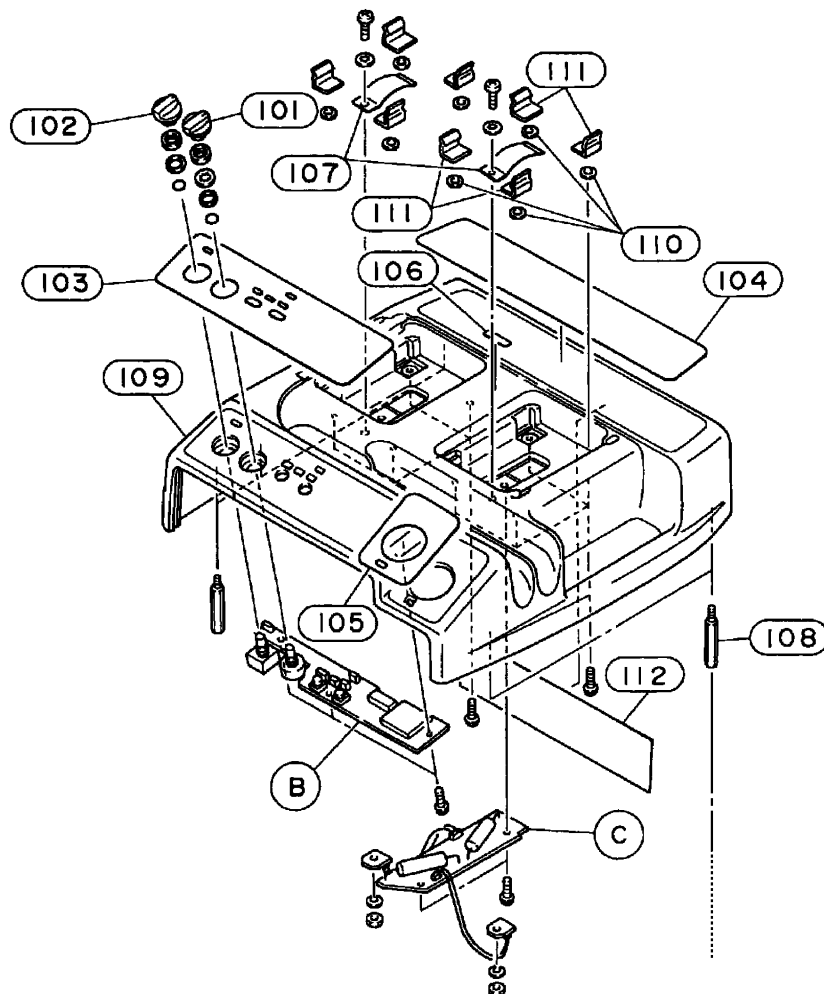

6. REPLACEABLE PARTS LIST

<u>No.</u>	<u>NK Part No.</u>	<u>Description</u>	
201	6124-023511B	Defibrillating keys panel (A/K version)	デフソウサパネル(エイ)(ロット)
	6124-027089	Defibrillating keys panel (C version)	デフソウサパネル(C)(ロット)
	6124-027721	Defibrillating keys panel (E version)	デフソウサパネル(E)(ロット)
	6124-028168	Defibrillating keys panel (F version)	デフソウサパネル(F)(ロット)
	6124-026615	Defibrillating keys panel (G version)	デフソウサパネルG(ロット)
	6124-026856	Defibrillating keys panel (R version)	デフソウサパネル(R)(ロット)
202	6113-020232A	Energy/Mode select knob (for TEC-7531)	ペーシングヨウエネルギーセレクト ツマミ
	6113-017601B	Energy/Mode select knob (for TEC-7521)	エネルギーセレクトツマミ
203	292078	Spacer nut UN18-2101-0031(L40)	カンカクナットUN18-2101- 0031(L40)
204†	515328	Bolt M3×6	テイトウキヤツプスクリユウM3*6
205†	6113-017628C	CRT board holder	CRTキバンコテイカナグ
206†	6113-017637C	Rubber defibrillation switches block	ラバーSW(デフソウサ)
207†	6113-017646C	Rubber monitor switches block	ラバーSW(モニタ)
208†	6114-052944B	Front packing	フロントパッキン
209†	6114-053043B	Battery cover packing	バッテリーフタパッキン
210†	6114-067296A	Rotary switch packing	ロータリーSWパッキン
211†	6114-073324	CRT filter	CRTフィルタ
212†	6122-002565C	Front casing silk	フロントシャーシシルクズ
213†	6124-020559B	Recorder switches silk	ラバーSW(レコーダ)シルクズ
214	1114-173766A	Speaker sponge	スピーカスポンジ
D	YZ-004H3	CRT Assy	
E†	UR-0146	Switch & LED Board	SW & LED
F	9771309	9771309 Board	9771309 P板
G	073653	Speaker EFB-VH36A	EFB-VH36A 圧電ブザー
H	WS-751V	Recorder Unit	レコーダユニット

†: The parts numbered 204, 205, 206, 207, 208, 209, 210 211, 213 and E are only available as an assembly, YZ-005H2 TEC-7500 Front Panel Assy (TEC-7500 フロントパネル Assy).

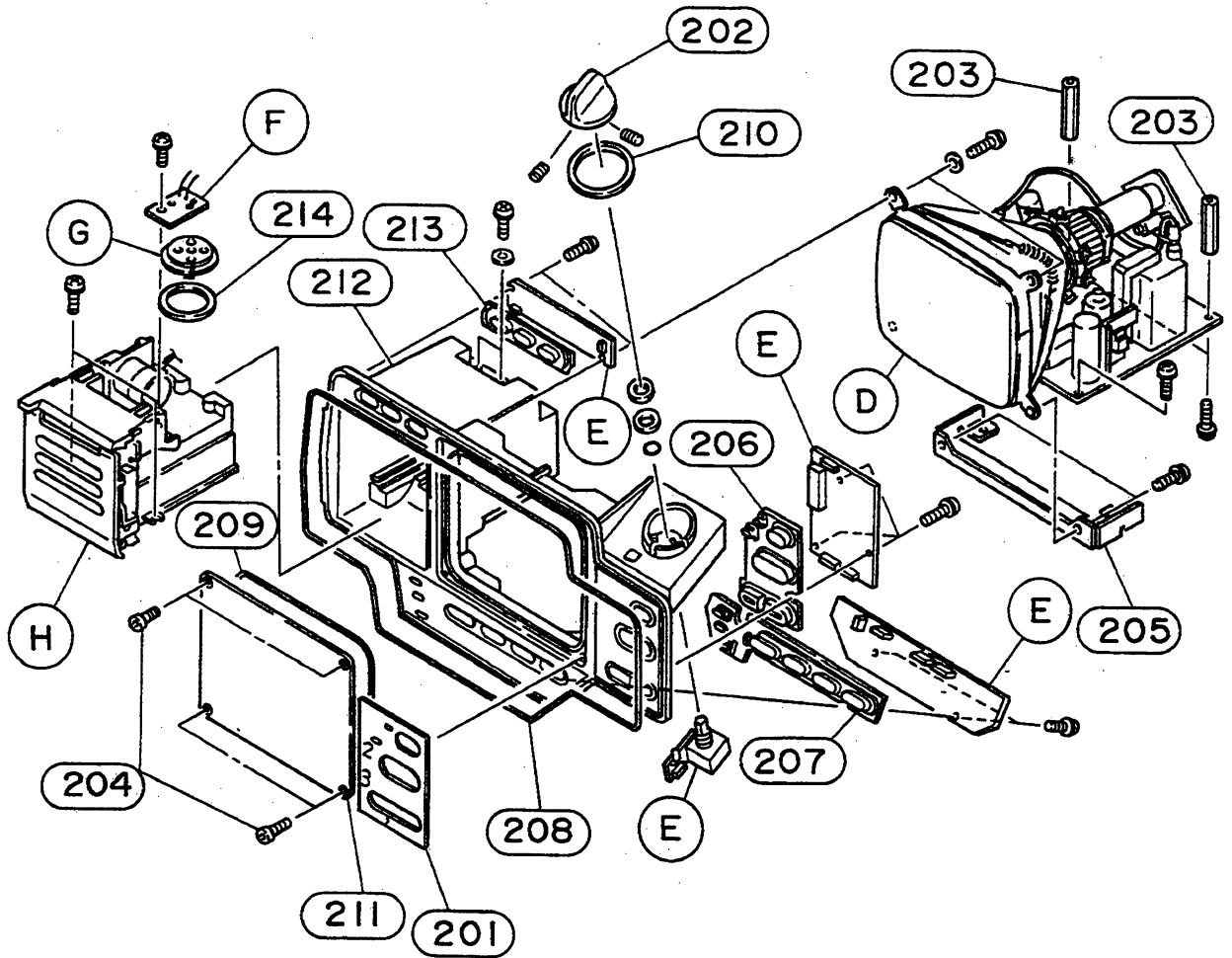

6. REPLACEABLE PARTS LIST

No.	NK Part No.	Description	
301	6124-023743A	Battery operation label (A/K version)	BATTトリセツパネル(ロット)(エイ)
	6124-027142	Battery operation label (C version)	BATTトリセツパネル(C)(ロット)
	6124-027739	Battery operation label (E version)	BATTトリセツパネル(E)(ロット)
	6124-028177	Battery operation label (F version)	BATTトリセツパネル(F)(ロット)
	6124-026606	Battery operation label (G version)	BATTトリセツパネルG(ロット)
	6124-026918	Battery operation label (R version)	BATTトリセツパネル(R)(ロット)
302	6144-005993	Equipotential terminal (A/C/E/F/K/R version)	アースタンシ(アヤメ)ASSY
	6114-081993	Equipotential terminal (G version)	アースターミナルG(L15)
303	128318	Spacer bolt UN18-2102-0002(L6)	カンカクボルトUN18-2102-0002(L6)
304	128024	Spacer bolt UN18-2101-0006(L10)	カンカクナットUN18-2101-0006(L10)
305	6111-002274C	Bottom casing.1	カブケース.1
306	6113-020384B	HV relay holder	コウアツリレーホルダ
307	6114-052962B	ECG connector bracket	ECGコネクタトリツケグ
308	6114-052989A	Bottom casing packing	ガイシュウパッキン(TEC-7502X)
309	6114-061747A	Volume board holder	ポリユームPバンオサエカナグ
310†	6114-072521A	Battery cover waterproof sheet	バッテリーフタボウスイシート
311†	6114-072539A	Battery cover.1	バッテリーフタ.1
312†	6114-072548B	Battery cover.2	バッテリーフタ.2
313	6114-073057A	Rear waterproof sheet	ボウスイシート(カブーシン)
314	6113-021632D	AC inlet bracket	ACインレットブラケット
315††	1113-046736A	Socket insulator	ソケットインシユレータ
318††	6113-017673C	Socket housing	ソケットハウジング
320†††	6112-006179B	1-F blank cover	1-Fブランクフタ
321†††	6114-053052A	1-F blank packing	1-Fブランクパッキン
322	6114-053043B	Battery cover packing	バッテリーフタパッキン
323	6114-072557	CRT board bracket.2	CRT Pバンホウネツカナグ.2
324	6113-023283A	CRT board bracket.1	CRT Pバンホウネツカナグ.1
325	6113-023274	CPU shield.2	CPUシールドバン.2
326	6113-023265B	CPU shield.1	CPUシールドバン.1
I	NKC-4840SA	HV Capacitor	高圧コンデンサー
J	NKL-701V	HV Inductor	高圧コイル
K	UR-0137	AC/DC Unit	電源ユニット
L	HV-751V	Relay Unit	リレーユニット
M	UR-0120	Mother Board	マザー
N	510832	HR16-17RA-6SA	HR16-17RA-6SA
O	US-0149	Pacing Output ROM Board	ベーシング出力ROM BD
P	313626	3P Inlet NC-174-10N-C	3PインレットNC-174-10N-C
Q	US-0119	CPU ROM Board	CPU ROM BD
R	LC-S2912NK	Battery	バッテリー

†: The parts numbered 310, 311 and 312 are only available as an assembly, YZ-004H6 TEC-7500 Battery Cover Assy (TEC-7500 バッテリーフタ Assy).

††: The parts numbered 315 and 318 are only available as an assembly, YZ-004H4 TEC-7500 Housing Assy (TEC-7500 ハウジング Assy).

†††: The parts numbered 320 and 321 are only available as an assembly, YZ-004H5 TEC-7500 Blank Cover Assy (TEC-7500 ブランクフタ Assy).

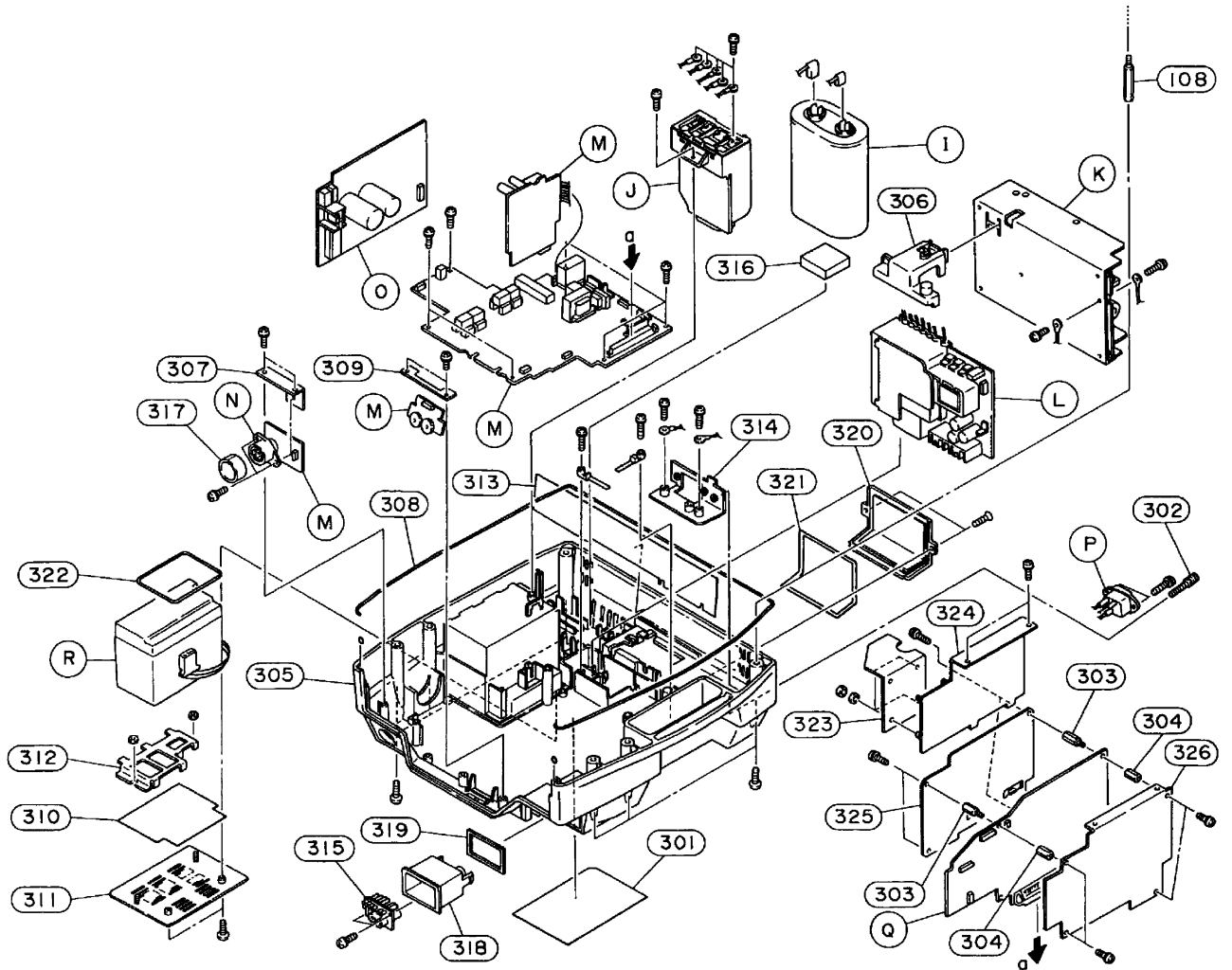

6-2 ND-752V External Paddle Parts

No.	NK Part No.	Description	
401	6124-025064	Paddle apex (for A/K version)	パネルAPEX(エイ)1(ロット)
	6124-027098	Paddle apex (for C version)	パネルAPEX (C) (ロット)
	6124-027748	Paddle apex (for E version)	パネルAPEX (E) (ロット)
	6124-028186	Paddle apex (for F version)	パネルAPEX (F)1 (ロット)
	6124-026651A	Paddle apex (for G version)	パネルAPEX G1 (ロット)
	6124-026865	Paddle apex (for R version)	パネルAPEX (R)1 (ロット)
402	6124-025073	Paddle ST contact (for A/K version)	パネルST CONTACT(エイ)1(ロット)
	6124-027106	Paddle ST contact (for C version)	パネルST CONTACT (C)1 (ロ)
	6124-027757	Paddle ST contact (for E version)	パネルST CONTACT (E)1 (ロ)
	6124-028195	Paddle ST contact (for F version)	パネルST CONTACT (F)1 (ロ)
	6124-026687A	Paddle ST contact (for G version)	パネルST CONTACT 1G(ロット)
	6124-026874	Paddle ST contact (for R version)	パネルST CONTACT (R)1 (ロ)
403	6124-025287	Charge label (for A/K version)	CHARGEラベルK718(エイ)(ロ)
	6124-027151	Charge label (for C version)	CHARGEラベルK718 (C)(ロ)
	6124-027775	Charge label (for E version)	CHARGEラベルK718 (E)(ロ)
	6124-028212	Charge label (for F version)	CHARGEラベルK718 (F)(ロ)
	6124-026678A	Charge label (for G version)	CHARGEラベルK718 G(ロ)
	6124-026936	Charge label (for R version)	CHARGEラベルK718 (R)(ロ)
404	1114-174293A	Discharge button	ハウデンボタン
405	6113-017664C	Release button	リリースツマミ
406	1114-174319	Lock spring 1	ロックバネ1
407	ND-611VA	Adult plate assy (for A version)	②電極ASSY
	ND-611V	Adult plate assy (for C/E/F/G/K/R version)	
A	ND-752VA	External paddle (for A version) (including parts 401 to 407)	外用パドル(401~407を含む)
	ND-752VC	External paddle (for C version) (including parts 401 to 407)	外用パドル(401~407を含む)
	ND-752VE	External paddle (for E version) (including parts 401 to 407)	外用パドル(401~407を含む)
	ND-752VF	External paddle (for F version) (including parts 401 to 407)	外用パドル(401~407を含む)
	ND-752VG	External paddle (for G version) (including parts 401 to 407)	外用パドル(401~407を含む)
	ND-752VK	External paddle (for K version) (including parts 401 to 407)	外用パドル(401~407を含む)
	ND-752VR	External paddle (for R version) (including parts 401 to 407)	外用パドル(401~407を含む)

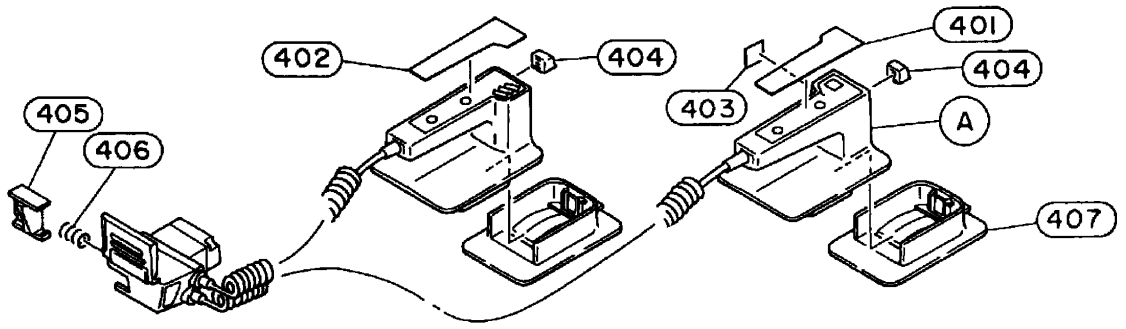

6-3 QI-751V Transmitter Interface Unit Parts

<u>No.</u>	<u>NK Part No.</u>	<u>Description</u>	
1	ZB-800P	ZB-800P Transmitter	送信機
2	6114-054425A	ZB-800P Top holder	ZB-800P トリツケバン
3	6114-062523C	ZB-800P Back holder	ZB トリツケカナグ
4	YZ-003H5	TEC-7500 QI cover Assy	TEC-7500 QI フタ Assy
5	6114-053052A	I/F blank packing	I/F ブランクパッキン
6	6114-054479D	ZB-800P I/F board bracket	ZB-800P I/F Pバン トリツケカナグ
7	UR-0152	ZB-800P I/F board	ZB I/F
8	6114-079051	ZB-800P Connector packing	ZB-800P コネクタパッキン

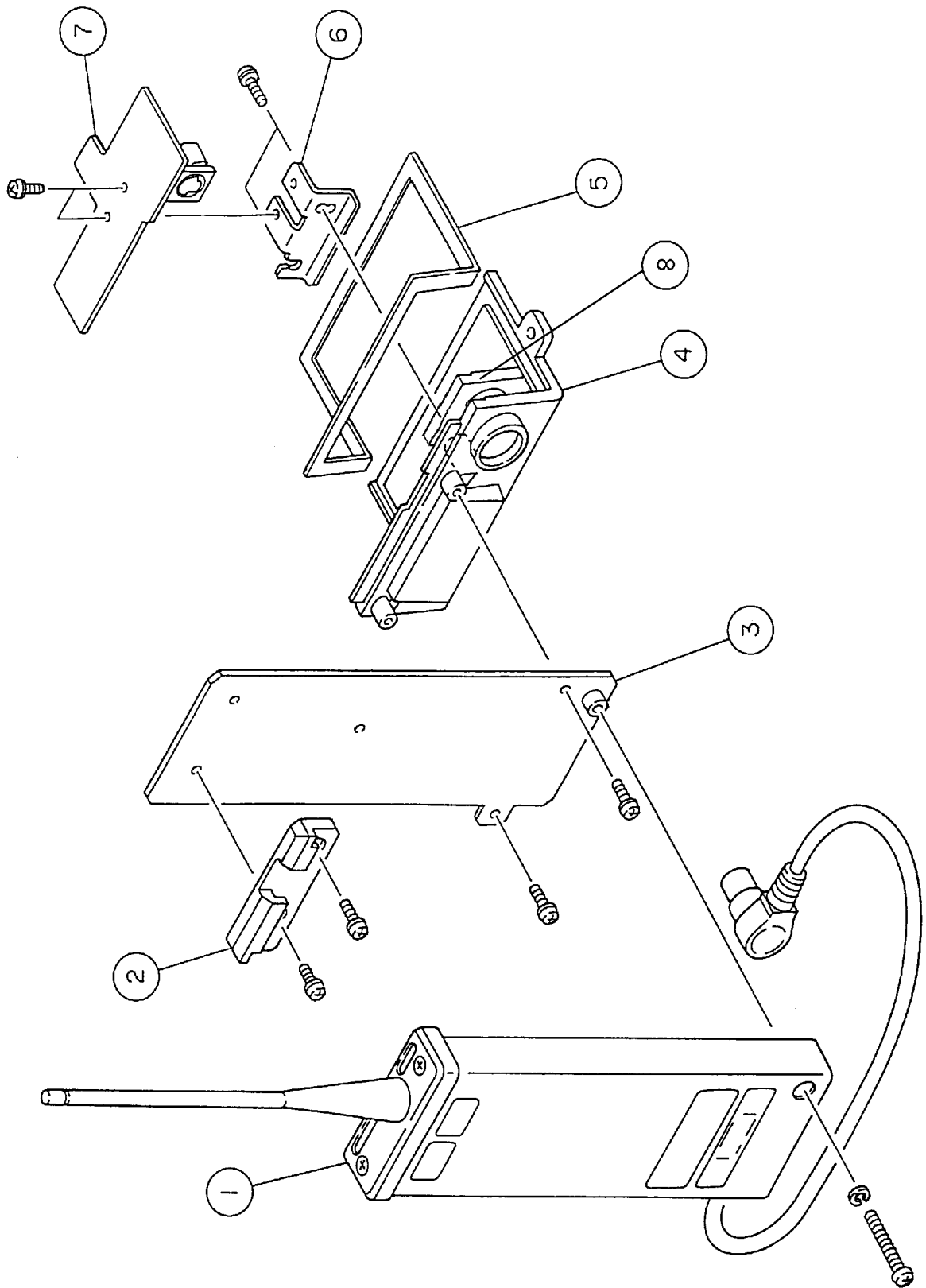

6-4 ZR-751V Telemetry Receiver Parts

<u>No.</u>	<u>NK Part No.</u>	<u>Description</u>	
1	6114-053052A	I/F blank packing	I/F ブランクパッキン
2	YZ-004H2	TEC-7500 ZR cover Assy	TEC-7500 ZR フタ Assy
3	6114-054283A	Connector packing	コネクタパッキン
4	6112-006384A	ZR-800P case	カブケース
5	6114-073966A	Antenna holder	アンテナホルダ
6	6114-054309A	Antenna holder plate	アンテナトリツケパン
7	6114-054318A	Board holder	PバントリツケLカナグ
8	6114-054336A	Packing	パッキン
9	6114-054345A	ZR-800P sponge	ZR-800P オサエスポンジ
10	6113-018101B	Case cover	フタ
11	128407	Hex support bolt M3 L=28	六角支柱 M3 L=28
A	ZR-800P	ZR-800P Receiver	
B	UR-0151	ZR I/F board	ZR インタフェイスボード

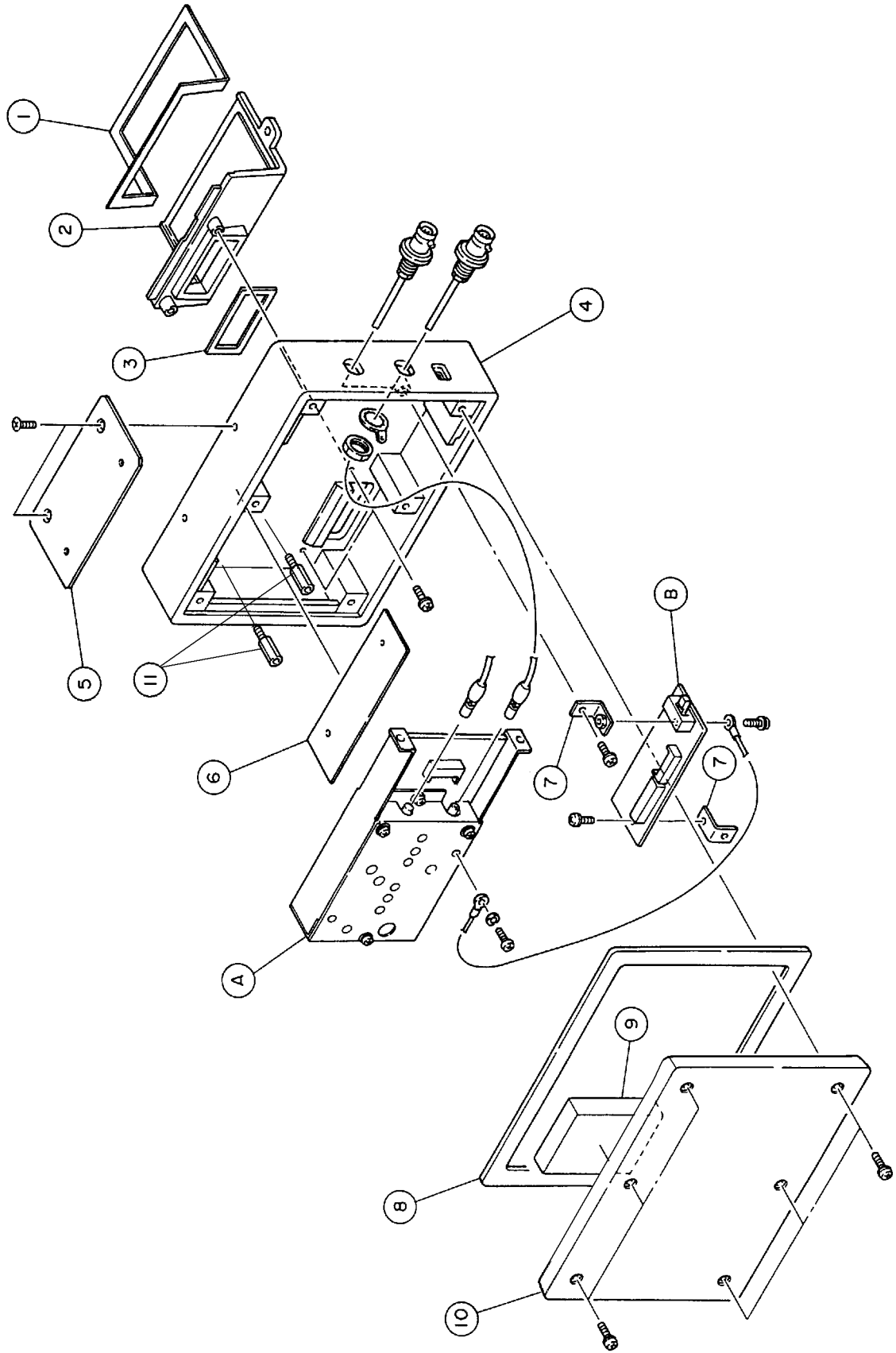

6-5 ZA-003P Antenna and Antenna Mount Parts

<u>No.</u>	<u>NK Part No.</u>	<u>Description</u>	
1	ZA-002P	Antenna	アンテナ
2	1112-020204D	Mount top casing	ケース ウエ
3	1114-225701A	Antenna holder	アンテナホルダ
4	319905	Antenna cable	アンテナコード 3CV-BNC 600 mm
5	1111-005036D	Mount bottom casing	ケース シタ
6	1114-225728B	Antenna base	アンテナキダイ
7	1114-225719A	Magnetic sheet	マグネットシート

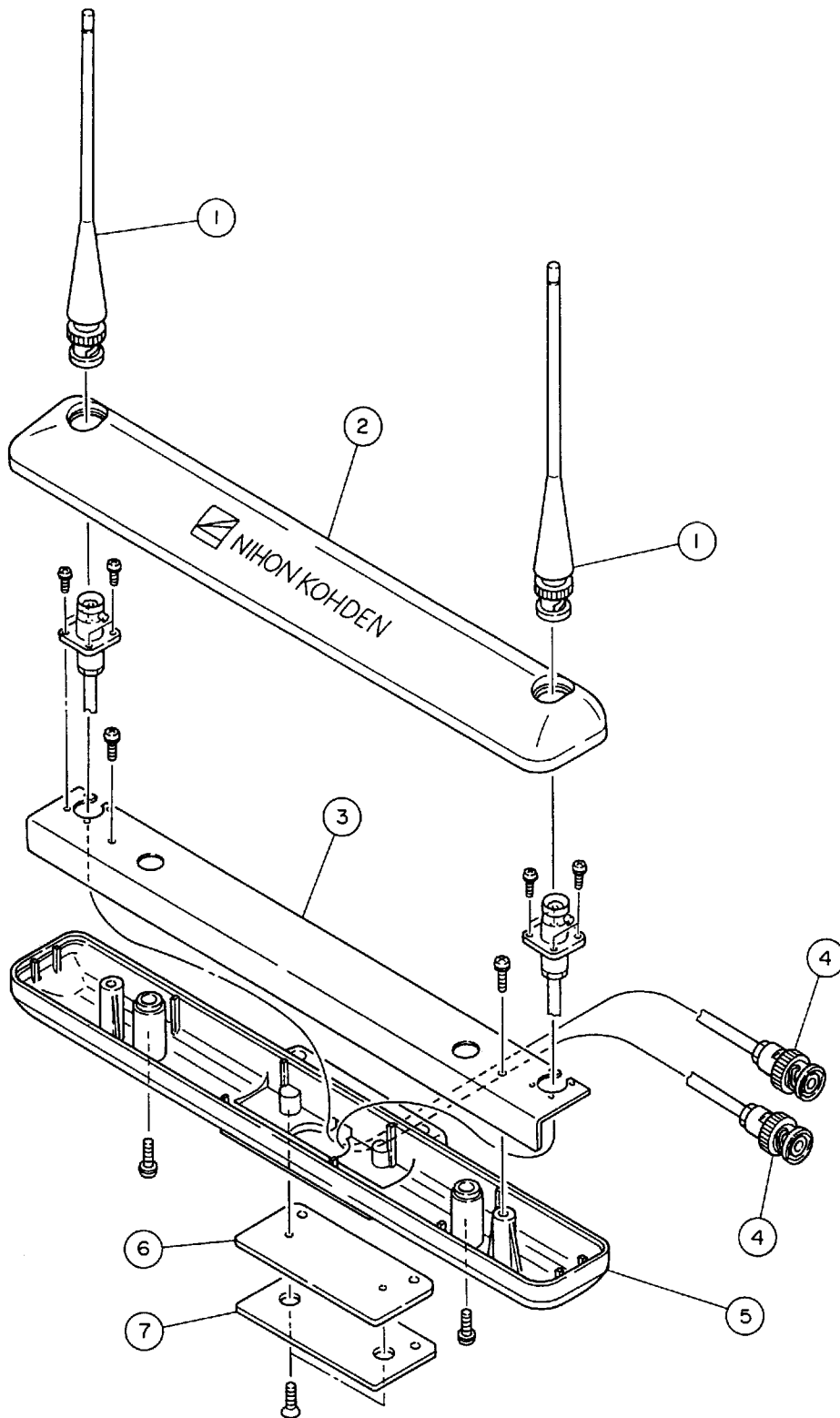

6-6 KD-001A Cart Parts

<u>No.</u>	<u>NK Part No.</u>	<u>Description</u>	
1	6111-003157D	Top plate (TEC)	トッププレート (TEC)
2	6112-007507B	Handle 350A	ハンドル 350A
3	6113-021971C	Handle grip R2	ハンドルグリップ R2
4	6113-021953C	Handle grip L2	ハンドルグリップ L2
5	6113-021962C	Handle grip R1	ハンドルグリップ R1
6	6113-021944C	Handle grip L1	ハンドルグリップ L1
7	6112-006606B	Basket	バスケット
8	6114-059901D	Basket holder	バスケットホルダ
9	6141-000264E	Frame assy 350-840K	フレーム ASSY 350-840K
10	6114-066154A	Belt 1	ベルト 1
11	6114-066172B	Belt holder 1	ベルトホルダ
12	6114-040182A	Base cover	ベースカバー
13	6112-807311A	Base R	ベース (R)
14	6112-007302A	Base L	ベース (L)
15	6112-006598D	Tray 1	トレイ 1
16	2219-015105	Fixing screw	ホントイコテイネジ
17	6112-006562G	Base plate 350	ベースプレート 350
18	6113-019234B	Guide rail	ガイドレール
19	6114-057271B	Screw 1	ネジ 1
20	6143-006967A	Caster NKC-150S	キャスタ NKC-150S
21	6143-006958A	Caster NKC-150	キャスタ NKC-150
22	6113-018716D	Slide rail L (option DI-001A)	スライドレール L
23	6113-061679D	Slide rail R (option DI-001A)	スライドレール R
24	6112-005698C	Tray 1 (option DI-001A)	トレイ 1
25	6113-023416A	Slide rail holder (option DI-001A)	スライドレールホルダ

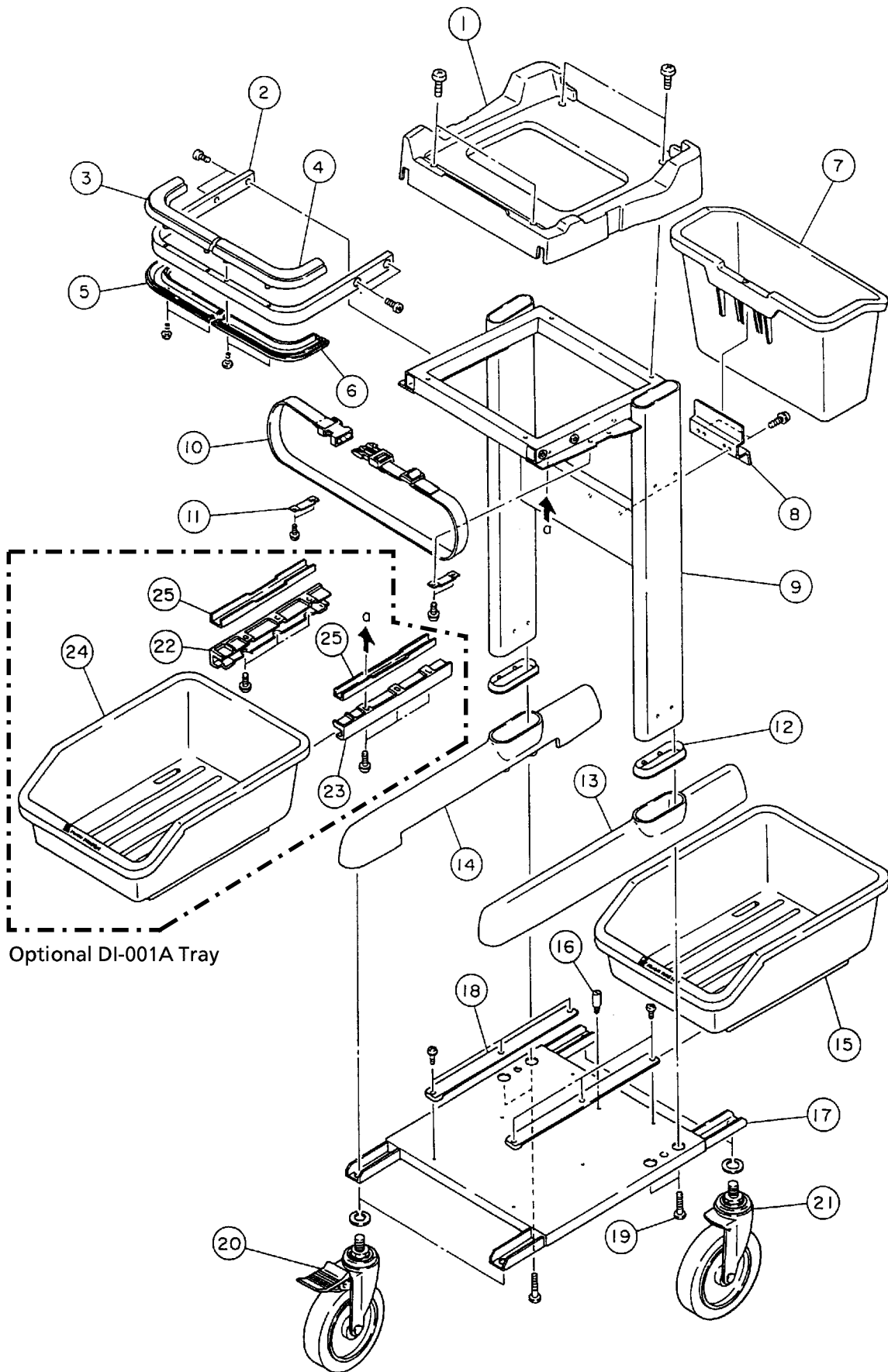

This page is intentionally left blank

Section 7 CONNECTOR PIN ASSIGNMENT

7-1	UR-0119 CPU Board	7.1
	7-1-1 CN1101	7.1
	7-1-2 CN1102	7.3
	7-1-3 CN1103	7.4
	7-1-4 CN1104	7.5
	7-1-5 CN1105	7.5
7-2	UR-0120 Mother Board	7.6
	7-2-1 CN020	7.6
	7-2-2 CN2032	7.6
	7-2-3 CN2051	7.6
	7-2-4 CN2071	7.6
	7-2-5 CN2141	7.7
	7-2-6 CN2142	7.9
	7-2-7 CN2143	7.9
	7-2-8 CN2144	7.9
	7-2-9 CN2151	7.10
	7-2-10 CN2152	7.10
	7-2-11 CN2153A	7.11
	7-2-12 CN2153B	7.11
	7-2-13 CN2154A	7.12
	7-2-14 CN2154B	7.12
	7-2-15 CN2155	7.13
	7-2-16 CN2222	7.13
	7-2-17 CN2223	7.14
	7-2-18 CN2224	7.14
	7-2-19 CN2225	7.14
	7-2-20 CN2226	7.14
7-3	UR-0121 HV Drive Board	7.15
	7-3-1 CN501	7.15
	7-3-2 CN511	7.15
	7-3-3 CN551	7.16
7-4	UR-0146 Switch & LED Board	7.17
	7-4-1 CN101	7.17
7-5	UR-0147 Test Load Board	7.18
	7-5-1 CN101	7.18
	7-5-2 CN102	7.18
	7-5-3 CN103	7.18
7-6	UR-0148 Pacing Switch Board	7.19
	7-6-1 CN101	7.19

7. CONNECTOR PIN ASSIGNMENT

7-7	UR-0149 Pacing Output Board	7.20
7-7-1	CN101	7.20
7-8	WS-751V Recorder Unit	7.21
7-8-1	CN018	7.21
7-8-2	CN019	7.21
7-8-3	CN060	7.22

7-1 UR-0119 CPU Board

7-1-1 CN1101

Pin No.	Signal	Pin No.	Signal
1	XPWR_ON	26	PDL_SEL1
2	LED_BAT_CHGING	27	PDL_SEL0
3	LED_BAT_CHGED	28	PDL_CNT1
4	LED_AC_ON	29	PDL_CNT0
5	THERM_AD_SEL	30	XLED_CHGS
6	TC_SEL0	31	LED_PDLCNT_B
7	TC_SEL1	32	XLED_PDLCNT_M
8	TC_SEL2	33	VIDEO
9	TST_WAVE0	34	XLED_PDLCNT_G
10	TST_WAVE1	35	ECG_CLK
11	CAL	36	EP_SYSCLK
12	XEP_OUT_CPU2	37	EP_CRNT_MON
13	EP_QCG	38	XEP_OUT_FS
14	EP_STRT	39	XEP_ERR_E1
15	PACE_DTCT	40	XEP_L_OFF
16	SPARE1	41	BZ_QRS
17	XLEAD_OFF1	42	BZ_KEY
18	XLEAD_OFF0	43	BZ_CHG
19	HUM	44	BZ_ALM
20	ECGLEAD_SEL2	45	XTH_CLK
21	REC_DATA	46	MT_DIS_B
22	ECGLEAD_SEL1	47	MT_PH_B
23	ECGLEAD_SEL0	48	MT_DIS_A
24	NONE	49	MT_PH_A
25	ECGIN_SEL	50	TH_LATCH

7. CONNECTOR PIN ASSIGNMENT

Pin No.	Signal	Pin No.	Signal
51	XREC_ENB	76	DGND
52	AD_REF	77	+6V
53	OVER_HEATHV	78	NONE
54	NONE	79	BATT_OFF
55	XOVER_CHGHV	80	TTR_AD
56	NONE	81	XTTR_INT
57	+5V	82	XBATT_TEST1
58	NONE	83	BATT_TEST2
59	+5V	84	BATT_USE
60	NONE	85	-6V
61	FS_EXT_RLYHV	86	NOTCHTG_BATT
62	EXT_RLYHV	87	BATT_VOL_AD
63	INT_RLYHV	88	XBATT_NG
64	CHG_ONHV	89	XBATT_CHGED
65	AGND	90	XBATT_DTCT
66	CHG_AD	91	XP_EMP
67	XKEY_PDL_CHG	92	XPW_DTCT_CPU
68	XKEY_PDL_DCHGL	93	ECG_PLR_AD
69	XKEY_PDL_DCHGR	94	THERM_AD
70	DGND	95	EP_CRNT_SET_AD
71	H_SYNC	96	+24V_EXT
72	DGND	97	ECG_WAVE
73	V_SYNC	98	E12_REG
74	DGND	99	+12V_REG
75	DGND	100	+8V

7-1-2 CN1102

Pin No.	Signal
1	DGND
2	+5V
3	XLED__SYNC__ON
4	LED__EVNT
5	LED__RPT
6	LED__REC
7	LED__CHG
8	XPWR__ON
9	LED__BAT__CHGING
10	LED__BAT__CHGED
11	LED__AC__ON
12	NONE
13	XKEY__PNL__DCHGL
14	XKEY__SET
15	XKEY__REC
16	XKEY__ENSEL3
17	XKEY__RPT
18	XKEY__ENSEL4
19	XKEY__ALM
20	XKEY__ENSEL5
21	XKEY__EVNT
22	XKEY__ENSEL1
23	XKEY__SENS
24	XKEY__PNL__DCHGR
25	XKEY__ENSEL2
26	XKEY__PNL__CHG
27	XKEY__SYNC
28	XKEY__LEAD

7. CONNECTOR PIN ASSIGNMENT

7-1-3 CN1103

Pin No.	Signal
1	XQRS_DTCT
2	+6V
3	EP_CRNT_MON
4	XEP_OUT_FS
5	AGND
6	XEP_RATE_ERR
7	XEP_CRNT_ERR
8	AD_REF
9	XKEY_EP_STRT
10	XKEY_EP_MODE
11	XKEY_EP_RATE0
12	XKEY_EP_RATE1
13	XKEY_EP_RATE2
14	XKEY_EP_RATE3
15	EP_STRT
16	LED_EP_ON
17	+5V
18	LED_EP_DMD
19	LED_EP_FIX
20	EP_CRNT_SET_AD
21	-6V
22	NONE
23	DGND
24	XEP_OUT_FS_CPU
25	SI_CPU2EP
26	SI_EP2CPU

7-1-4 CN1104

Pin No.	Signal
1	XSI_CPU2ZB
2	+8V
3	ZR_LE
4	DGND
5	+12V_REG
6	ZR_DATA
7	ZB_XRST
8	ZR_RSSI_AD
9	E12_REG
10	+24V_EXT
11	ZB_TCLK
12	ZR_CLK
13	+6V
14	ZR_SEL2
15	ZR_RD
16	XUL0
17	ECG_OUT
18	ZR_RT
19	AGND
20	ZR_SEL1
21	SI_CPU2PRB
22	XSI_ZB2CPU
23	+5V
24	ZR_SEL3

7-1-5 CN1105

Pin No.	Signal
1	XDCHG
2	DGND

7-2 UR-0120 Mother Board

7-2-1 CN020

Pin No.	Signal
A	RA(R)
B	LA(L)
C	LL(F)
D	V(C)
E	RL(RF)
F	SH

7-2-2 CN2032

Pin No.	Signal
1	BRT SRC
2	BRT ADJ
3	BRT GND
4	BZ QRS
5	BZ QRS ADJ
6	ED

7-2-3 CN2051

Pin No.	Signal
1	ECG(+)
2	ECG(-)

7-2-4 CN2071

Pin No.	Signal
1	+ 24V AC
2	+ 24V AC
3	XPW DTCT
4	E24 AC
5	E24 AC

7-2-5 CN2141

Pin No.	Signal	Pin No.	Signal
1	XPWR_ON	26	PDL_SEL1
2	LED_BAT_CHGING	27	PDL_SEL0
3	LED_BAT_CHGED	28	PDL_CNT1
4	LED_AC_ON	29	PDL_CNT0
5	THERM_AD_SEL	30	XLED_CHGS
6	TC_SEL0	31	LED_PDLCNT_B
7	TC_SEL1	32	XLED_PDLCNT_M
8	TC_SEL2	33	VIDEO
9	TST_WAVE0	34	XLED_PDLCNT_G
10	TST_WAVE1	35	ECG_CLK
11	CAL	36	EP_SYSCLK
12	XEP_OUT_CPU2	37	EP_CRNT_MON
13	EP_QCG	38	XEP_OUT_FS
14	EP_STRT	39	XEP_ERR_E1
15	PACE_DTCT	40	XEP_L_OFF
16	SPARE1	41	BZ_QRS
17	XLEAD_OFF1	42	BZ_KEY
18	XLEAD_OFF0	43	BZ_CHG
19	HUM	44	BZ_ALM
20	ECGLEAD_SEL2	45	XTH_CLK
21	REC_DATA	46	MT_DIS_B
22	ECGLEAD_SEL1	47	MT_PH_B
23	ECGLEAD_SEL0	48	MT_DIS_A
24	NONE	49	MT_PH_A
25	ECCIN_SEL	50	TH_LATCH

7. CONNECTOR PIN ASSIGNMENT

Pin No.	Signal	Pin No.	Signal
51	XREC_ENB	76	ED
52	AD_REF	77	+6V
53	OVER_HEATHV	78	NONE
54	NONE	79	BATT_OFF
55	XOVER_CHGHV	80	TTR_AD
56	NONE	81	XTTR_INT
57	+5V	82	XBATT_TEST1
58	NONE	83	BATT_TEST2
59	+5V	84	BATT_USE
60	NONE	85	-6V
61	FS_EXT_RLYHV	86	NOTCHTG_BATT
62	EXT_RLYHV	87	BATT_VOL_AD
63	INT_RLYHV	88	XBATT_NG
64	CHG_ONHV	89	XBATT_CHGED
65	EA	90	XBATT_DTCT
66	CHG_AD	91	XP_EMP
67	XKEY_PDL_CHG	92	XPW_DTCT_CPU
68	XKEY_PDL_DCHGL	93	ECG_PLR_AD
69	XKEY_PDL_DCHGR	94	THERM_AD
70	ED	95	EP_CRNT_SET_AD
71	H_SYNC	96	+24V_EXT
72	ED	97	ECG_WAVE
73	V_SYNC	98	E12_REG
74	ED	99	+12V_REG
75	ED	100	+8V

7-2-6 CN2142

Pin No.	Signal
1	+12V_REG
2	+12V_REG
3	OVER_HEATHV
4	EXT_ERR_HV
5	E12_REG
6	E12_REG
7	CHG_ONHV
8	INT_RLYHV
9	INT_RLYHV
10	EXT_RLYHV
11	FS_EXT_RLYHV
12	XOVER_CHGHV
13	CHG_AD
14	CHG_ERR_HV

7-2-7 CN2143

Pin No.	Signal
1	9-24V
2	E9-24

7-2-8 CN2144

Pin No.	Signal
1	+12V_REG
2	E12_REG
3	H_SYNC
4	E12_REG
5	VIDEO
6	E12_REG
7	V_SYNC
8	E12_REG
9	NONE
10	BRT_SRC
11	BRT_ADJ
12	BRT_GND

7. CONNECTOR PIN ASSIGNMENT

7-2-9 CN2151

Pin No.	Signal
1	XKEY_PDL_CHG
2	PDL_SEL0
3	PDL_SEL1
4	LED_PDL_CHG
5	ED
6	XKRY_PDL_DCHGR
7	XKEY_PDL_DCHGL
8	LED_PDLCNT_GO
9	LED_PDLCNT_MB
10	NONE

7-2-10 CN2152

Pin No.	Signal
1	EP_SYSCLK
2	EP_STRT
3	EP_CRNT_SET_AD
4	EP_CRNT_MON
5	XEP_OUT_FS
6	XEP_OUT_CPU2
7	XEP_ERR_E1
8	XEP_L_OFF
9	+5V
10	+6V
11	-6V
12	9-24V
13	ED
14	EA
15	E9-24
16	NONE

7-2-11 CN2153A

Pin No.	Signal
1	+5V
2	ED
3	MT_DIS_A
4	MT_DIS_B
5	MT_PH_A
6	MT_PH_B
7	AD_REF
8	XP_EMP
9	SP
10	XREC_ENB
11	REC_THERM
12	XTH_CLK
13	TH_LATCH
14	REC_DATA
15	BATT_TEMP

7-2-12 CN2153B

Pin No.	Signal
1	+5V
2	ED
3	MT_DIS_A
4	MT_DIS_B
5	MT_PH_A
6	MT_PH_B
7	AD_REF
8	XP_EMP
9	SP
10	XREC_ENB
11	REC_THERM
12	XTH_CLK
13	TH_LATCH
14	REC_DATA
15	BATT_TEMP

7. CONNECTOR PIN ASSIGNMENT

7-2-13 CN2154A

Pin No.	Signal
1	BATT+
2	BATT+
3	BATT+
4	BATT+
5	EBAT
6	EBAT
7	EBAT
8	EBAT
9	XBAT_DTCT
10	REC_9-24V
11	+12V_REG
12	EA
13	EA

7-2-14 CN2154B

Pin No.	Signal
1	BATT+
2	BATT+
3	BATT+
4	BATT+
5	EBAT
6	EBAT
7	EBAT
8	EBAT
9	XBAT_DTCT
10	REC_9-24V
11	+12V_REG
12	EA
13	EA

7-2-15 CN2155

Pin No.	Signal
1	+24V__AC
2	EA

7-2-16 CN2222

Pin No.	Signal
1	CH1
2	XCH1
3	CH2
4	XCH2
5	P5
6	Short with pin No. 9
7	+5V
8	ED
9	Short with pin No. 6
10	PS
11	NONE
12	NONE

7. CONNECTOR PIN ASSIGNMENT

7-2-17 CN2223

Pin No.	Signal
1	+24V_REC
2	+24V_REC
3	E_REC
4	E_REC
5	+5V_H
6	REC_THERM
7	STROBE
8	STROBE
9	XTH_CLK
10	TH_LATCH
11	REC_DATA
12	E_REC
13	E_REC
14	+24V_REC
15	+24V_REC

7-2-18 CN2224

Pin No.	Signal
1	BATT+
2	EBAT
3	XBAT_DTCT

7-2-19 CN2225

Pin No.	Signal
1	SP
2	ED

7-2-20 CN2226

Pin No.	Signal
1	EA

7-3 UR-0121 HV Drive Board

7-3-1 CN501

Pin No.	Signal
1	9-24V
2	E9-24

7-3-2 CN511

Pin No.	Signal
1	+12V__REG
2	+12V__REC
3	OVER__HAETHV
4	EXT__ERR__HV
5	E12__REG
6	E12__REG
7	CHG__ONHV
8	INT__RLYHV
9	INT__RLYHV
10	EXT__RLYHV
11	FS__EXT__RLYHV
12	XOVER__CHGHV
13	CHG__AD
14	CHG__ERR__HV

7. CONNECTOR PIN ASSIGNMENT

7-3-3 CN551

Pin No.	Signal
1	EXT RLY 1
2	EXT RLY 2
3	INT RLY 1
4	INT RLY 2

7-4 UR-0146 Switch & LED Board

7-4-1 CN101

Pin No.	Signal
1	DGND
2	+5V
3	XLED_SYNC_ON
4	LED_EVNT
5	LED_RPT
6	LED_REC
7	LED_CHG
8	XPWR_ON
9	LED_BAT_CHGING
10	LED_BAT_CHGED
11	LED_AC_ON
12	NONE
13	XKEY_PNL_DCHGL
14	XKEY_SET
15	XKEY_REC
16	XKEY_ENSEL3
17	XKEY_RPT
18	XKEY_ENSEL4
19	XKEY_ALM
20	XKEY_ENSEL5
21	XKEY_EVNT
22	XKEY_ENSEL1
23	XKEY_SENS
24	XKEY_PNL_DCHGR
25	XKEY_ENSEL2
26	XKEY_PNL_CHG
27	XKEY_SYNC
28	XKEY_LEAD

7-5 UR-0147 Test Load Board**7-5-1 CN101**

Pin No.	Signal
1	XDCHG_CHK
2	ED

7-5-2 CN102

Pin No.	Signal
	TEST_AP

7-5-3 CN103

Pin No.	Signal
	TEST_ST

7-6 UR-0148 Pacing Switch Board

7-6-1 CN101

Pin No.	Signal
1	XQRS_DTCT
2	+6V
3	EP_CRNT_MON
4	XEP_OUT_FS
5	EA
6	XEP_RATE_ERR
7	XEP_CRNT_ERR
8	AD_REF
9	XKEY_EP_STRT
10	XKEY_EP_MODE
11	XKEY_EP_RATE0
12	XKEY_EP_RATE1
13	XKEY_EP_RATE2
14	XKEY_EP_RATE3
15	EP_STRT
16	LED_EP_ON
17	+5V
18	LED_EP_DMD
19	LED_EP_FIX
20	EP_CRNT_SET_AD
21	-6V
22	NONE
23	ED
24	XEP_OUT_FS_CPU
25	SI_CPU2EP
26	SI_EP2CPU

7-7 UR-0149 Pacing Output Board

7-7-1 CN101

Pin No.	Signal
1	EP_SYSCLK
2	EP_STRT
3	EP_CRNT_SET_AD
4	EP_CRNT_MON
5	XEP_OUT_FS
6	XEP_OUT_CPU2
7	XEP_ERR_E1
8	XEP_L_OFF
9	+5V
10	+6V
11	-6V
12	9-24V
13	ED
14	EA
15	E9-24
16	NONE

7-8 WS-751V Recorder Unit

7-8-1 CN018

Pin No.	Signal
1	CH1
2	XCH1
3	CH2
4	XCH2
5	MSW__1
6	MSW__2
7	+5V
8	DGND
9	P5
10	PS
11	M5
12	MS

7-8-2 CN019

Pin No.	Signal
1	+24V__REC
2	+24V__REC
3	EREC
4	EREC
5	+5V__H
6	REC__THERM
7	STROBE
8	STROBE
9	XTH__CLK
10	TH__LATCH
11	REC__DATA
12	EREC
13	EREC
14	+24V__REC
15	NONE

7. CONNECTOR PIN ASSIGNMENT

7-8-3 CN060

Pin No.	Signal
1	SP
2	DGND

Nihon Kohden Corporation**Head Office**

31-4, Nishiochiai 1-chome, Shinjuku-ku,
Tokyo 161-8560, Japan

International Division Sales Department

Tokyo (Head Office)

Telephone: 81(3) 5996-8036

Facsimile: 81(3) 5996-8100

Nihon Kohden Singapore PTE LTD

70 Shenton Way, #14-05 Marina House

SINGAPORE 079118

Telephone: 224-6700

Facsimile: 224-6216

Nihon Kohden China Service Centers

北京医疗器械维修中心

北京丰台西路十七号

电话: 381-3181

上海光电医用电子仪器有限公司维修站

上海市徐汇区徐家汇蒲西路221号 电话: 481-4406

沈阳红星医疗器械维修服务中心

沈阳市和平区常德街59号

电话: 36-6856

日本光电仪器广州维修站

广州中山二路49号

电话: 77-5472

四川省医疗设备维修服务中心

四川省成都市青羊宫

电话: 66-9981 转214

Nihon Kohden America, Inc.

2601 Campus Drive, Irvine, CA 92612, U.S.A.

Telephone: (714) 250-3959

Facsimile: (714) 250-3210

Nihon Kohden Europe GmbH

Saalburgstraße 157, Bürohaus 1,

D-61350 Bad Homburg v.d.H., Germany

Telephone: (06172) 309200

Facsimile: (06172) 303611

Nihon Kohden UK Ltd

462 London Road, Isleworth,

Middlesex TW7 4EP, U.K.

Telephone: 0181-568-5655

Facsimile: 0181-560-9066

Nihon Kohden Benelux Training Center

c/o Hoekloos

Kabelweg 44

1014 BB Amsterdam

The Netherlands

Telephone: 020-5811211

Facsimile: 020-681-0016

The model and serial number of your instrument are identified on the rear or bottom of the unit. Write the model and serial number in the spaces provided below. Whenever you call your distributor concerning this instrument, these two pieces of information should be mentioned for quick and accurate service.

Model _____

Serial Number _____

YOUR DISTRIBUTOR