

## Repair instructions

### UNIVERSAL 320 UNIVERSAL 320 R



**Andreas Hettich GmbH & Co. KG**  
**Föhrenstraße 12, D-78532 Tuttlingen / Germany**  
**Phone (07461) 705-0**  
**Fax (07461) 705-125**  
**info@hettichlab.com, service@hettichlab.com**  
**www.hettichlab.com**

© 2005 by Andreas Hettich GmbH & Co. KG

All rights reserved. No part of this publication may be reproduced without the prior written permission of the copyright owner.

Modifications reserved!

**AR1401EN / 10.08**

## Contents

1	Introduction .....	5
2	Symbol meanings.....	5
3	Description of the centrifuge.....	6
3.1	Operating panel (A2).....	6
3.2	Electronics U320 resp. U320R (A1) .....	6
3.3	Special features .....	7
3.4	Brake resistor (R1).....	7
3.5	Motor (M1) / tacho system (B4, B2.1) .....	7
3.6	Imbalance sensor (B2.2).....	8
3.7	Motor-driven lid lock (A3) .....	8
3.8	Cooling system.....	8
3.9	Safety devices.....	9
4	Troubleshooting procedures.....	9
5	Error messages.....	10
5.1	MAINS RESET.....	10
5.2	Brief description .....	10
5.3	Description and elimination of errors.....	12
6	Settings and interrogations.....	23
6.1	Summary of the possible settings and interrogations.....	23
6.2	Acoustic signal .....	24
6.3	Operating hours .....	25
6.4	Blank the machine type in the display .....	26
6.5	Automatic repetition of the centrifugation run.....	27
6.6	Function test .....	28
6.7	Logging the occurred faults .....	32
6.8	Checking the motor slippage.....	34
6.9	Parameter interrogation .....	35
6.10	Display of the frequency converter temperature and the measured speeds ...	36

6.11	Imbalance values.....	37
6.11.1	Setting the imbalance switch-off.....	37
6.11.2	Imbalance values of the last centrifugation run.....	39
6.11.3	Imbalance values during centrifugation run.....	40
6.12	Cooling parameters.....	41
6.12.1	Switch-on delay of the Standby cooling.....	41
6.12.2	Pre-cooling speed.....	42
6.12.3	Temperature values during standstill.....	43
6.12.4	Temperature values during centrifugation run.....	44
6.12.5	Compensate the temperature sensors.....	45
6.13	Initialise and read out the EEPROM.....	47
6.14	Activate the functions for the operation with an external refrigerating/heating circulator in the programme.....	49
6.15	Setting the display contrast.....	50
7	Functional check after a repair.....	51
8	General arrangement of the components.....	52
9	Technical documents.....	56
9.1	Tachometer code configuration of the rotors.....	56
9.2	Cooling diagram.....	57
9.3	Connecting diagram.....	59
9.3.1	Abbreviations of the cable colours.....	59
9.3.2	Connecting diagram mains input UNIVERSAL 320 / 320 R.....	59
9.3.3	Connecting diagram UNIVERSAL 320 / 320 R.....	60
9.3.4	Connecting diagram UNIVERSAL 320 R Heating/cooling.....	62
9.4	Technical specifications.....	64

## 1 Introduction

- Repairs must only be carried out by personnel authorised to do so by the manufacturer.



Interventions and modifications at centrifuges, which have been conducted by persons not authorized by the Andreas Hettich GmbH & Co. KG company, are at their own risk and entail the loss of all guarantee and liability claims. In such an event any guarantee claim or liability claim against the Andreas Hettich GmbH & Co. KG company expires.

- Only original spare parts and original accessories licensed by the Andreas Hettich GmbH & Co. KG company are allowed to be utilised.



If no original spare parts or no original accessories are used, any guarantee claim or liability claim against the Andreas Hettich GmbH & Co. KG company ceases to exist.

- Information about the operation of the centrifuge please see operating instructions.
- We reserve all rights for these technical documents.

## 2 Symbol meanings



Symbol on the machine:

Attention, general hazard area.

Before using the centrifuge implicitly read the operating instructions and pay attention to the safety relevant references!



Symbol in this document:

Attention, general hazard area.

This symbol refers to safety relevant warnings and indicates possibly dangerous situations.

The non-adherence to these warnings can lead to material damage and injury to personal.



Symbol in this document:

This symbol refers to important circumstances.

### 3 Description of the centrifuge

These microprocessor controlled centrifuges mainly consist of the following electrical components:

- Operating panel (A2)
- Electronics U320 (A1) resp. Electronics U320R (A1)
- Motor with 2 speed sensors (B2.1, B4) and imbalance sensor (B2.2)
- Brake resistor (R1)
- Motor-driven lid lock (A3)
- Cooling system

#### 3.1 Operating panel (A2)

The buttons, the LCD display, the status LEDs and the acoustic beeper are located on the operating panel.

The operating panel is connected with the Electronics U320 (A1) via a 16-pole flat ribbon cable.

#### 3.2 Electronics U320 resp. U320R (A1)

There are 2 microprocessors on the Electronics U320 . Both processors (control- and drive-processor) are communicating internal via a serial interface.

The control-processor carries out the following tasks:

- Reading in the buttons and controlling the LCD display and the LEDs.
- Saving of 9 run programs.
- Evaluating the errors recognized by the frequency converter.
- Voltage supply and evaluation of both speed sensors (tacho).
- Voltage supply and evaluation of the imbalance sensor.
- Controlling the motor-driven lid lock.
- Voltage supply 15 V DC and 5 V DC for the operating panel.
- Evaluating the temperature sensors and controlling the cooling.
- Evaluating the overtemperature switch in the centrifuge chamber.
- Status indication with an orange respectively a red LED:

All functions are all right:	the yellow LED lights up
Case of error:	the yellow LED flashes
Control-processor does not clock:	the yellow LED does not light up

The frequency converter carries out the following tasks:

- Generating the motor current supply  
(three-phase current with variable frequency and voltage)

Functional description: The supply voltage is rectified, smoothed and chopped into a pulse width pattern in three bridge elements with a microprocessor.

- Monitoring the motor current.
- Evaluating the overtemperature switch in the motor.

- The braking chopper transfers the electrical energy produced during braking, in the 230 V version from a voltage of approx. 400 Volt and in the 115 V version from a voltage of approx. 209 Volt, to the brake resistor in a controlled manner.
- Status indication with a green LED:
  - Standby: the green LED lights up
  - Centrifugation run: the green LED lights up
  - Case of error: the green LED flashes

If the drive processor detects an error, it switches off the motor.

### 3.3 Special features

- Multiprocessor concept:  
The control- and the drive-processor monitoring one another. If one processor stops working, the other processor switches off the drive.
- Interface concept:  
The information transmission is monitored with an additional check sum.
- Hardware concept:  
All safety related switches are break contacts. This also ensures that loose contacts and cable rupture can be detected.

### 3.4 Brake resistor (R1)

- An overtemperature fuse protects the brake resistor against fire. If the braking chopper has a short circuit, the brake resistor becomes hot due to the high current, and the overtemperature fuse (F1) disconnects the supply voltage of the centrifuge.

### 3.5 Motor (M1) / tacho system (B4, B2.1)

- The motor is a three-phase asynchronous motor with two pairs of poles.
- A speed sensor (B4, speedometer) which is screwed onto the motor receives
  - the rotor code information and
  - the speed information (6 pulses per revolution)from the magnets of the tacho ring attached to the rotor.
- An additional speed sensor (B2.1, speedometer) is together with the imbalance sensor (B2.2) in one housing. This housing is screwed to the bottom of the motor. The speed signal (1 pulse per revolution) will be triggered by a magnet fixed at the motor axle. This signal is used for the release of the motor-driven lid lock.
- The Electronics U320 (A1) monitors and regulates the speed.
  - Double safety: The drive-processor has been programmed in such a way that it switches off the drive when the speed is higher than the permissible rotor speed. Then error message "FU/CCI-ERROR 84" will be displayed.
- The Electronics U320 (A1) monitors the rotor standstill.

### 3.6 Imbalance sensor (B2.2)

- An electronic sensor monitors the imbalance.
- The imbalance sensor and the speed sensor (B2.1) are together in one housing, screwed to the bottom of the motor.
- Imbalance is detected only in running mode (starting, centrifuging and braking).
- If impermissible imbalance is detected, the drive switches off and the rotor slows down braked until it stops.

### 3.7 Motor-driven lid lock (A3)

- The lid can be opened only if the Electronics U320 (A1) has detected rotor standstill.
- By pressing the key  the lid opens motor-driven.
- The motor locks the lid only if both lid brackets have actuated both switches in the lid lock and the rotor has standstill.
- The centrifuge can only be started when the lid is closed.

### 3.8 Cooling system

The cooling system is a hermetical system.

The cooling system consists of the following components:

- Compressor
- Cooling tubes around the centrifuge chamber (evaporator)
- Condenser
- Dryer
- Fan
- Temperature sensor T1 (B1) and overtemperature switch in the centrifuge chamber
- Temperature sensor T3 (B3) on the condenser

In the housing of the temperature sensor T1 also the overtemperature switch is included. With centrifuges with cooling the drive switches off, when the temperature is  $> 60^{\circ}\text{C}$ .

The refrigerant will be cooled down with a fan. The speed of the fan is controlled dependent to the temperature at the condenser.

When opening the lid of the centrifuge, the cooling system switches off. The cooling system is controlled dependent to the speed of the rotor.



### 3.9 Safety devices

Mains switch	⇒ with thermal overload protection
Over voltage protection and radio interference suppression filter	⇒ on Electronics U320 (A1)
Additional radio interference suppression filter	⇒ in mains input circuit (only with 120 V model)
Frequency converter	⇒ on Electronics U320 (A1), electrically protected
Motor	⇒ Overtemperature switch (> 140 °C)
Centrifuge chamber	⇒ Overtemperature switch (> 60 °C)

### 4 Troubleshooting procedures

- Fuses in installation in which centrifuge is installed are intact.
- Supply voltage present at (see circuit diagram):
  - Connecting cable
  - Appliance plug
  - Mains switch
  - Electronics U320 (A1), plug S100
- Look for the displayed error code in the chapter "Error messages".
- Remedy the error according to the instructions.
- Carry out a functional check after every repair and whenever a component is replaced, see chapter "Functional check after a repair".

## 5 Error messages

### 5.1 MAINS RESET

- Switch off the mains switch.
- Wait at least for 10 seconds and then switch on the mains switch again.

### 5.2 Brief description

Error designation	No.	Brief description	Page
TACHO-ERROR	1	Speed sensor on top of the motor: Speedometer pulses break down during rotation	12
TACHO-ERROR	2	No speedometer pulses after start command	12
IMBALANCE	(3)*	Imbalance on motor axle	13
CONTROL-ERROR	4	Lid lock error: lid opened without recognizing rotor is at standstill	13
N > MAX	5	Excessive speed error, 250 RPM above n-max of rotor	13
CONTROL-ERROR	6	Lid lock error	14
CONTROL-ERROR	8	Lid lock error	14
ROTORCODE	10.1	No start code recognized	14
ROTORCODE	10.2	Invalid rotor code	14
ROTORCODE	10.3	Error during reading the rotor code	15
MAINS INTERRUPT	(11)*	Mains interruption	15
N < MIN	13	Speed error: slippage is too high	15
CONTROL-ERROR	21	Faulty speed measurement	16
CONTROL-ERROR	22	Electronics U320 (A1): I <sup>2</sup> C bus	16
CONTROL-ERROR	23	Operating panel: Display-Timeout	16
CONTROL-ERROR	25	Electronics U320 (A1): EEPROM	16
CONTROL-ERROR	27	Electronics U320 (A1): EPROM	16
CONTROL-ERROR	29	Electronics U320 (A1): RAM	16
SER I/O-ERROR	30	Interface - error: Software protocol	16
SER I/O-ERROR	31	Interface - error: Timeout	16
SER I/O-ERROR	33	Interface - error: Software protocol parity bit	16
SER I/O-ERROR	36	Interface - error: NAK	16

\* Error number will not be displayed

Error designation	No.	Brief description	Page
°C / *-ERROR	51	Overtemperature on condenser	17
°C / *-ERROR	52	Overtemperature in centrifuge chamber	17
°C / *-ERROR	53	Temperature sensor in centrifuge chamber is defective	17
°C / *-ERROR	55	Temperature sensor on condenser is defective	18
FU/CCI-ERROR	60	Faulty release signal to frequency converter (drive-processor)	18
FU/CCI-ERROR	61	Frequency converter - error: computing section	18
FU/CCI-ERROR	62	Frequency converter - error: undervoltage	19
FU/CCI-ERROR	63	Frequency converter - error: overcurrent	19
FU/CCI-ERROR	64	Frequency converter - error: overvoltage	19
FU/CCI-ERROR	67	Frequency converter - error: overtemperature in motor	20
FU/CCI-ERROR	68	Frequency converter - error: overtemperature in frequency converter	20
FU/CCI-ERROR	82	Frequency converter - error: short circuit cut-off	20
FU/CCI-ERROR	83	Frequency converter - error: PFC-overload	20
FU/CCI-ERROR	84	Frequency converter - error: Frequency converter recognizes excess speed	21
FU/CCI-ERROR	85	Frequency converter - error: "Watchdog" in frequency converter had triggered	21
SENSOR-ERROR	90	No mains synchronisation	21
SENSOR-ERROR	91	Imbalance sensor - error	21
SENSOR-ERROR	92	Imbalance sensor - error	21
SENSOR-ERROR	93	Imbalance sensor – error: monitoring of the temperature	22
NO ROTOR	(95)*	No rotor installed	22
TACHO-ERROR	96	Speed sensor at the bottom of the motor: Speedometer pulses break down during rotation	22
N > ROTORMAX	---	Speed in the selected program higher than the maximum speed of the rotor (Nmax)	22

\* Error number will not be displayed

### 5.3 Description and elimination of errors

#### TACHO - ERROR 1

Error	During centrifugation the speedometer pulses of the speed sensor (B4) on top of the motor are interrupted.
Error consequence	The rotor slows down braked until it stops. No further user operation is possible. After about 3 minutes the lid lock will be enabled and the lid can be opened.
Cause of error / measurements	<ul style="list-style-type: none"> <li>• Speed sensor (B4) on top of the motor defective or loose contact on plug. Measure supply voltage on plug S700 / Electronics U320 (A1) pin 2 – pin 3 (+14-18 VDC). Measure speedometer pulses on plug S700 / Electronics U320 (A1) pin 2 - pin 4 (signal).</li> <li>• Electronics U320 (A1) is defective.</li> </ul>
Error code reset	Open the lid. Turn the rotor by hand and perform a MAINS RESET while the rotor is turning.

#### TACHO - ERROR 2

Error	After start-up no speedometer pulses will be received from both speed sensors (B4, B2.1).
Error consequence	The rotor slows down braked until it stops. No further user operation is possible. After about 3 minutes the lid lock will be enabled and the lid can be opened.
Cause of error / measurements	<ul style="list-style-type: none"> <li>• Motor is blocked or is defective.</li> <li>• Loose contact on motor plug S103.</li> <li>• Both speed sensors (B4, B2.1) defective or loose contact on plug. <ul style="list-style-type: none"> <li>– Speed sensor on top of the motor: Measure supply voltage on plug S700 / Electronics U320 (A1) pin 2 – pin 3 (+14-18 VDC). Measure speedometer pulses on plug S700 / Electronics U320 (A1) pin 2 - pin 4 (signal).</li> <li>– Speed sensor at the bottom of the motor: Measure supply voltage on plug S600 / Electronics U320 (A1) pin 6 – pin 8 (+14-18 VDC). Measure speedometer pulses on plug S600 / Electronics U320 (A1) pin 6 - pin 7 (signal).</li> </ul> </li> <li>• Electronics U320 (A1) is defective.</li> </ul>
Error code reset	Open the lid. Turn the rotor by hand and perform a MAINS RESET while the rotor is turning.

## IMBALANCE

Error	Imbalance on motor axle.
Error consequence	The rotor slows down braked until it stops.
Cause of error / measurements	<ul style="list-style-type: none"> <li>• Weight difference in rotor components.</li> <li>• Check the maximum permissible imbalance values in the "SELECT MODE".</li> <li>• Imbalance sensor (B2.2) is defective. Measure on Electronics U320 (A1) / plug S600, pin 6 – pin 1 (+5 VDC).</li> <li>• Electronics U320 (A1) is defective.</li> </ul>
Error code reset	Open the lid or perform a MAINS RESET.

## CONTROL - ERROR 4

Error	Lid lock is open during centrifugation.
Error consequence	The rotor slows down without braking until it stops. No further user operation is possible.
Cause of error	<ul style="list-style-type: none"> <li>• An emergency unlocking was performed during the centrifugation run.</li> <li>• Electronics U320 (A1) is defective.</li> </ul>
Error code reset	After the rotor has stopped perform a MAINS RESET. After turning the centrifuge on again, press the button  so that the motor-driven lid locking once again assumes the normal position (opened).

## N > MAX 5

Error	Excess speed. The speed measured by the speed sensor (B4) is 250 RPM higher than the n-max speed of the rotor.
Error consequence	The rotor slows down braked until it stops. No further user operation is possible.
Cause of error / measurements	<ul style="list-style-type: none"> <li>• Speed sensor (B4) on top of motor defective or loose contact on plug. Measure supply voltage on plug S700 / Electronics U320 (A1) pin 2 – pin 3 (+14-18 VDC). Measure speedometer pulses on plug S700 / Electronics U320 (A1) pin 2 - pin 4 (signal).</li> <li>• Electronics U320 (A1) is defective.</li> </ul>
Error code reset	Perform a MAINS RESET.

### **CONTROL - ERROR 6**

Error Lid lock error

Error consequence No further user operation is possible.

Cause of error

- Mains voltage is too low. Admissible mains voltage see chapter "Technical specification".
- The motor of the lid lock runs too slowly or it is blocked.

Error code reset Perform a MAINS RESET.

### **CONTROL - ERROR 8**

Error Lid lock error

Error consequence No further user operation is possible.

Cause of error

- Electronics U320 (A1) is defective.

Error code reset Open the lid. Turn the rotor by hand and perform a MAINS RESET while the rotor is turning.

### **ROTOCODE 10.1**

Error Start code of the rotor coding not recognized.

Error consequence The rotor slows down braked until it stops.

Cause of error

- Magnetic code on the rotor is defective.
- Electronics U320 (A1) is defective.

Error code reset Open the lid or perform a MAINS RESET.

### **ROTORCODE 10.2**

Error An invalid rotor code was read in during start-up.

Error consequence The rotor slows down braked until it stops.

Cause of error

- Magnetic code on the rotor is defective.
- Electronics U320 (A1) is defective.

Error code reset Open the lid or perform a MAINS RESET.

### ROTORCODE 10.3

Error	Error during reading the rotor code.
Error consequence	The rotor slows down braked until it stops.
Cause of error	<ul style="list-style-type: none"><li>• Magnetic code on the rotor is defective.</li><li>• Electronics U320 (A1) is defective.</li></ul>
Error code reset	Open the lid or perform a MAINS RESET.

### MAINS INTERRUPT

Error	Interruption of mains supply during centrifugation.
Error consequence	During the interruption of the mains supply the rotor slows down without braking until it stops. After the interruption of the mains supply the rotor slows down braked until it stops.
Cause of error	<ul style="list-style-type: none"><li>• Power supply has failed.</li><li>• Loose contact in electrical connections.</li></ul>
Error code reset	Open the lid and press the <b>START / IMPULS</b> key.



This error **cannot** be reset by a MAINS RESET.

### N < MIN 13

Error	Insufficient speed, motor slippage is too high. The centrifuge control can readjust the speed by max. 10 % (control limit). This error is displayed if the rotor speed (ACTUAL speed) is lower than the SET speed - 10%.
Error consequence	The rotor slows down braked until it stops. No further user operation is possible.
Cause of error	<ul style="list-style-type: none"><li>• Motor is labouring (damage to bearings).</li><li>• Motor has a short-circuited coil (coil is defective).</li><li>• Loose contact in the electrical connections.</li><li>• Electronics U320 (A1) is defective.</li></ul>
Error code reset	Perform a MAINS RESET.

### **CONTROL – ERROR 21**

Error            Faulty speed measurement.

Error            The rotor slows down braked until it stops.  
consequence    No further user operation is possible.

Cause of error    • Magnetic code on the rotor is defective.  
                      • Electronics U320 (A1) is defective.

Error code reset Perform a MAINS RESET.

### **CONTROL - ERROR 22, 25, 27, 29**

Error            Internal error on Electronics U320 (A1).

Error            The rotor slows down braked until it stops.  
consequence    No further user operation is possible.

Cause of error    • Electronics U320 (A1) is defective.

Error code reset Perform a MAINS RESET.

### **CONTROL – ERROR 23**

Error            Internal error on operating panel

Error            The rotor slows down braked until it stops.  
consequence    No further user operation is possible.

Cause of error    • Operating panel is defective.

Error code reset Perform a MAINS RESET.

### **SER I/O - ERROR 30 - 36**

Error            Interface - error

Error            The rotor slows down without braking until it stops.  
consequence    No further user operation is possible.

Cause of error    • Electronics U320 (A1) is defective.

Error code reset Perform a MAINS RESET.



### °C / \* -ERROR 51

Error	Overtemperature on condenser
Error consequence	The rotor slows down braked until it stops. No further user operation is possible.
Cause of error / measurements	<ul style="list-style-type: none"> <li>• Temperature on condenser &gt; 58°C.</li> <li>• The temperature sensor on condenser is defective. Measure on Electronics U320 (A1) / plug S603, pin 1 – pin 2. voltage &gt; 3.31 V = Temperature on condenser &gt; 58°C Voltage at 25°C = 2.98 V (± 20 mV) A temperature change of 1°K causes a voltage change of 10 mV.</li> <li>• Electronics U320R (A1) is defective.</li> <li>• Fan (M3) is defective.</li> </ul>
Error code reset	Perform a MAINS RESET.

### °C / \* -ERROR 52

Error	Overtemperature in centrifuge chamber
Error consequence	The rotor slows down braked until it stops. No further user operation is possible.
Cause of error / measurements	<ul style="list-style-type: none"> <li>• Overtemperature switch in centrifuge chamber is defective. Measure on Electronics U320R (A1) / plug S604, pin 3 – pin 4 Switch closed: 0 VDC Switch opened: +5 VDC</li> <li>• Electronics U320R (A1) is defective.</li> <li>• Cooling is defective.</li> </ul>
Error code reset	Perform a MAINS RESET.

### °C / \* -ERROR 53

Error	The measured temperature in the centrifuge chamber is out of range.
Error consequence	The rotor slows down braked until it stops. No further user operation is possible.
Cause of error / measurements	<ul style="list-style-type: none"> <li>• The temperature sensor in the centrifuge chamber is defective. Measure on Electronics U320R (A1) / plug S604, pin 1 – pin 2. voltage &lt; 0.5 V = short circuit voltage &gt; 4.5 V = disruption Voltage at 25°C = 2.98 V (± 20 mV) A temperature change of 1°K causes a voltage change of 10 mV.</li> <li>• Electronics U320R (A1) is defective.</li> </ul>
Error code reset	Perform a MAINS RESET.

### °C / \* -ERROR 55

Error The measured temperature on the condenser is out of range.

Error consequence The rotor slows down braked until it stops.  
No further user operation is possible.

Cause of error / measurements

- The temperature sensor on condenser is defective.  
Measure on Electronics U320R (A1) / plug S603, pin 1 – pin 2.  
voltage < 0.5 V = short circuit  
voltage > 4.5 V = disruption  
voltage at 25°C = 2.98 V (±20 mV)  
A temperature change of 1°K causes a voltage change of 10 mV.
- Electronics U320R (A1) is defective.

Error code reset Perform a MAINS RESET.

### FU / CCI - ERROR 60

Error Error when checking the enable signal to frequency converter after the start command.  
The lid switch (S2) for the left hook or the lid switch (A3/S1) for the right hook has opened during the centrifugation run.

Error consequence The rotor slows down without braking until it stops.  
No further user operation possible except opening the lid.

Cause of error

- Switches of the lid lock defective.  
Check the function of both switches, see pg. 28, chapter 6.6, item 19 (ADC 5, ADC 7).  
Pull out plug S602 and check the function of the switches at the plug of the cable between pin 1 - pin 2 (S2, left hook) and pin 3 - pin 4 (A3/S1, right hook).
- Electronics U320R (A1) is defective.

Error code reset Perform a MAINS RESET.

### FU / CCI - ERROR 61

Error Frequency converter - error. Computing section

Error consequence The rotor slows down without braking until it stops.  
No further user operation is possible.

Cause of error

- Electronics U320 (A1) is defective.

Error code reset Perform a MAINS RESET.

### **FU / CCI - ERROR 62**

Error	Frequency converter - error. Undervoltage in intermediate circuit.
Error consequence	The rotor slows down without braking until it stops. No further user operation is possible.
Cause of error	<ul style="list-style-type: none"><li>• Mains voltage is too low. Admissible mains voltage see chapter "Technical specification".</li><li>• Electronics U320 (A1) is defective.</li></ul>
Error code reset	Perform a MAINS RESET.

### **FU / CCI - ERROR 63**

Error	Frequency converter - error. Overcurrent.
Error consequence	The rotor slows down without braking until it stops. No further user operation is possible.
Cause of error	<ul style="list-style-type: none"><li>• Motor impedance is too low.</li><li>• Electronics U320 (A1) is defective.</li></ul>
Error code reset	Perform a MAINS RESET.

### **FU / CCI - ERROR 64**

Error	Frequency converter - error. Overvoltage. Voltage in intermediate circuit > 426 V DC at 230 V > 230 V DC at 115 V This error normally only occurs when the drive is being braked.
Error consequence	The rotor slows down without braking until it stops. No further user operation is possible.
Cause of error / measurements	<ul style="list-style-type: none"><li>• Check the electrical wiring and the plug (S300) of the brake resistor.</li><li>• Overtemperature fuse on brake resistor has blown.</li><li>• Brake resistor is defective.</li><li>• Electronics U320 (A1) is defective.</li></ul>
Error code reset	Perform a MAINS RESET.

### FU / CCI - ERROR 67

Error            Overtemperature in the motor.

Error            The rotor slows down braked until it stops.  
 consequence    No further user operation is possible.

Cause of error /  
 measurements

- Overtemperature switch opens because of overtemperature in the motor.  
 Remove plug S103 and measure at the plug between pin 7 – pin 9:  
 Switch closed:  $\approx 0 \Omega$   
 Switch opened:  $\infty \Omega$
- Electronics U320 (A1) is defective.
- Motor is defective.

Error code reset    Perform a MAINS RESET.

### FU / CCI - ERROR 68

Error            Overtemperature in frequency converter.

Error            The rotor slows down braked until it stops.  
 consequence    No further user operation is possible.

Cause of error

- Insufficient heat conduction from frequency converter to support sheet of electronics U320 (A1). There is no, or not enough, heat-conducting paste between frequency converter and support sheet.
- Full-load operation and an ambient temperature  $> 45^\circ\text{C}$ .
- Electronics U320 (A1) is defective.

Error code reset    Perform a MAINS RESET.

### FU / CCI - ERROR 82

Error            Frequency converter - error. Short circuit cut-off.

Error            The rotor slows down without braking until it stops.  
 consequence    No further user operation is possible.

Cause of error /  
 measurements

- Short circuit in motor.  
 Remove plug S103 and check at the plug pin 1, pin 3, pin 5 the resistance of the motor coils, see chapter "Connecting diagram".
- Electronics U320 (A1) is defective.

Error code reset    Perform a MAINS RESET.

### FU / CCI - ERROR 83

Error            Frequency converter - error. PFC-Overload (PFC = Power Factor Control = switching power supply on mains side).

Error            The rotor slows down braked until it stops.  
 consequence    No further user operation is possible.

Cause of error

- Electronics U320 (A1) is defective.

Error code reset    Perform a MAINS RESET.

#### **FU / CCI - ERROR 84**

Error	Frequency converter recognises excess speed. It evaluates the signals from the speed sensor at the bottom of the motor. The error will be activated when the speed exceeds the following limit value: maximum speed of the rotor x 1,05. e.g.: With a max. speed of 14000 RPM it will be 14700 RPM.
Error consequence	The rotor slows down braked until it stops. No further user operation is possible.
Cause of error	<ul style="list-style-type: none"><li>• Electronics U320 (A1) is defective.</li></ul>
Error code reset	Perform a MAINS RESET.

#### **FU / CCI - ERROR 85**

Error	"Watchdog" in frequency converter Discrepancy in program procedure.
Error consequence	The rotor slows down braked until it stops. No further user operation is possible.
Cause of error	<ul style="list-style-type: none"><li>• Electronics U320 (A1) is defective.</li></ul>
Error code reset	Perform a MAINS RESET.

#### **SENSOR - ERROR 90 (only in centrifuges with cooling)**

Error	No mains synchronisation
Error consequence	The rotor slows down braked until it stops. No further user operation is possible.
Cause of error	<ul style="list-style-type: none"><li>• Electronics U320 (A1) is defective.</li></ul>
Error code reset	Perform a MAINS RESET.

#### **SENSOR - ERROR 91 - 92**

Error	Imbalance sensor
Error consequence	The rotor slows down braked until it stops. No further user operation is possible.
Cause of error	<ul style="list-style-type: none"><li>• Check the plug S600 and the wires.</li><li>• Imbalance sensor (B2.2) is defective.</li><li>• Electronics U320 (A1) is defective.</li></ul>
Error code reset	Perform a MAINS RESET.

### SENSOR – ERROR 93

Error	The temperature of the imbalance sensor is out of range
Error consequence	The rotor slows down braked until it stops. No further user operation is possible.
Cause of error	<ul style="list-style-type: none"><li>• Imbalance sensor (B2.2) is defective.</li><li>• Electronics U320 (A1) is defective.</li></ul>
Error code reset	Perform a MAINS RESET.

### NO ROTOR

Error	Start without rotor
Error consequence	The rotor slows down braked until it stops. No further user operation is possible.
Cause of error	<ul style="list-style-type: none"><li>• No rotor installed.</li><li>• Speed sensor (B4) on top of motor is defective.</li><li>• Electronics U320 (A1) is defective.</li></ul>
Error code reset	Perform a MAINS RESET.

### TACHO – ERROR 96

Error	During centrifugation the speedometer pulses of the speed sensor (B2.1) at the bottom of the motor are interrupted.
Error consequence	The rotor slows down braked until it stops. No further user operation is possible. After about 3 minutes the lid lock will be enabled and the lid can be opened.
Cause of error / measurements	<ul style="list-style-type: none"><li>• Speed sensor (B2.1) at the bottom of the motor defective or loose contact on plug. Measure supply voltage on plug S600 / Electronics U320 (A1) pin 6 – pin 8 (+14-18 VDC). Measure speedometer pulses on plug S600 / Electronics U320 (A1) pin 6 - pin 7 (signal).</li><li>• Electronics U320 (A1) is defective.</li></ul>
Error code reset	Open the lid. Turn the rotor by hand and perform a MAINS RESET while the rotor is turning.

### N > ROTORMAX

Error	Speed in the selected program greater than the maximum speed of the rotor (Nmax).
Error consequence	No start possible.
Error code reset	Check and reduce the set speed.

## 6 Settings and interrogations

All settings and interrogations are performed via the keyboard.

The corresponding menus are selected by pressing keys or combinations of keys.

### 6.1 Summary of the possible settings and interrogations

- Set the Acoustic signal, see chapter "6.2"
- Inquiry and the change of the operating hours, see chapter "6.3"
- Blank the machine type in the display, see chapter "6.4"
- Automatic repetition of the centrifugation run, see chapter "6.5"
- Function test of the individual components, see chapter "6.6"
- Logging the occurred faults, see chapter "6.7"
- Checking the motor slippage, see chapter "6.8"
- Parameter interrogation, see chapter "6.9"
- Display of the frequency converter temperature and the measured speeds, see chapter "6.10"
- Display of the Imbalance values and setting the imbalance switch-off, see chapter "6.11"
- Display and setting of the the cooling parameters, see chapter "6.12"
- Initialisation and read out the EEPROM, see chapter "6.13"
- Activation of the functions in the programme for the operation with an external refrigerating/heating circulator, see chapter "6.14".
- Setting the display contrast, see chapter "6.15"

## 6.2 Acoustic signal

The acoustic signal sounds:



- Upon the appearance of a disturbance in 2 second intervals.
- After completion of a centrifugation run and rotor standstill in 30 second intervals.

The acoustic signal is stopped by opening the lid or pressing any key.



The signal after completion of the centrifugation run can be activated or deactivated, if the rotor is at standstill.

It is at any time possible to terminate the procedure by pressing the  key.

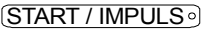
Action	Display / Comment
1. Switch on the mains switch	→ <b>UNI 320R Vx.xx</b> Machine type and program version
	→ <b># 30 4000 01:00</b> Display of the centrifugation data
2. Keep the  key pressed for 8 seconds	→ <b>PROG RCL = X</b>
Display after 8 seconds	→ <b>SOUND / BELL XXX</b>
• Turn the control knob 	→ <b>SOUND / BELL ON</b> Set to <b>OFF</b> or <b>ON</b>
3. Press the  key	→ <b>*** ok ***</b> The setting will be stored. The menu will be terminated automatically.



### 6.3 Operating hours



The inquiry and the change of the operating hours is only possible if the rotor is at standstill.

It is at any time possible to terminate the procedure by pressing the **STOP / OPEN** key.







Action	Display / Comment
1. Switch on the mains switch	<p>→ <b>UNI 320R Vx.xx</b> Machine type and program version</p> <p>→ <b># 30 4000 01:00</b> Display of the centrifugation data</p>
2. Keep the <b>SELECT</b> key pressed for 8 seconds	→ <b>PROG RCL = X</b>
Display after 8 seconds	→ <b>SOUND / BELL XXX</b>
3. Press the <b>SELECT</b> key	<p>→ <b>CONTROL: XXXXXh</b> Operating hours are displayed</p> <p> If the operating hours should not be changed, press the <b>STOP / OPEN</b> key to terminate the procedure.</p>
4. Press the <b>RCF</b> key	→ <b>CONTROL:&gt; XXXXXh&lt;</b> Operating hours can be set
• Turn the control knob $\odot$	→ <b>CONTROL:&gt; XXXXXh&lt;</b> Set the operating hours
5. Press the <b>START / IMPULS</b> key	<p>→ <b>*** ok ***</b> The setting will be stored. The menu will be terminated automatically.</p>

## 6.4 Blank the machine type in the display

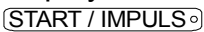
The display of the machine type after switching on the unit can be blanked.

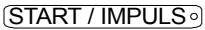

It is at any time possible to terminate the procedure by pressing the  key twice.

Action	Display / Comment
1. Switch on the mains switch	→ <b>UNI 320R Vx.xx</b> Machine type and program version
2. While <b>UNI 320R Vx.xx</b> is displayed, keep the  key and the  key pressed simultaneously for 16 seconds	→ <b>* SELECT MODE *</b>  If <b>KEYBOARD-ERROR</b> will be displayed, a key was briefly released. The entire procedure must be carried out again.
3. Press the  key <b>so often</b> until the following will be displayed	→ <b>GOTO SETUP</b>
4. Press the  key	→ <b>* SETUP-MODE *</b>
5. Press the  key <b>so often</b> until the following will be displayed	→ <b>OEM VERSION OFF</b>
<ul style="list-style-type: none"> <li>• Turn the control knob </li> </ul>	→ <b>OEM VERSION ON</b> ON = machine type will not be displayed OFF = machine type will be displayed
6. Press the  key	→ <b>*** ok ***</b> The setting will be stored → <b>*** exit ***</b> The menu will be terminated automatically

## 6.5 Automatic repetition of the centrifugation run

For test purposes the automatic repetition of the centrifugation run can be selected. The break time between the centrifugation runs can be set. This automatic repetition remains activated until the centrifuge will be switched off.



It is at any time possible to terminate the procedure by pressing the **STOP / OPEN** key.

If no key is pressed for a period of 8 seconds the menu will be terminated automatically.

Action	Display / Comment
1. Switch on the mains switch	→ <b>UNI 320R Vx.xx</b> Machine type and program version
2. While <b>UNI 320R Vx.xx</b> is displayed, keep the <b>START / IMPULS</b> key and the <b>STOP / OPEN</b> key pressed simultaneously for 16 seconds	→ <b>* SELECT MODE *</b>  If <b>KEYBOARD-ERROR</b> will be displayed, a key was briefly released. The entire procedure must be carried out again.
3. Press the <b>SELECT</b> key so often until the following will be displayed	→ <b>GOTO CNT.RUN</b>
4. Press the <b>START / IMPULS</b> key	→ <b>t/break = ∞</b> break between the centrifugation runs
• Turn the control knob $\odot$	→ <b>t/break = XX</b> The break time is settable from 1 second to 99 minutes and 59 seconds, in 1 second increments
5. Press the <b>START / IMPULS</b> key	→ <b>*** ok ***</b> The break time is only temporarily stored. After switching the centrifuge off this time is again deleted. The menu will be terminated automatically.

### 6.6 Function test





The individual components of the centrifuge can be tested on its function.





In order to be able to check the function of the speed sensors the lid must be opened before the starting the function test.

It is at any time possible to terminate the procedure by pressing the **STOP / OPEN** key twice.

Action	Display / Comment
1. Switch on the mains switch	→ <b>UNI 320R Vx.xx</b> Machine type and program version
2. While <b>UNI 320R Vx.xx</b> is displayed, keep the <b>START / IMPULS</b> key and the <b>STOP / OPEN</b> key pressed simultaneously for 16 seconds	→ <b>* SELECT MODE *</b> If <b>KEYBOARD-ERROR</b> will be displayed, a key was briefly released. The entire procedure must be carried out again.
3. Press the <b>SELECT</b> key so often until the following will be displayed	→ <b>GOTO TEST</b>
4. Press the <b>START / IMPULS</b> key	→ <b>* TEST MODE *</b>
5. Press the <b>SELECT</b> key	→ <b>Software Vx.xx</b> Program version
6. Press the <b>SELECT</b> key	→ Test of the LC-display. All segments of the display light up.  All segments of the display deactivated (no display)
• Turn the control knob $\odot$ one step to the right	
7. Press the <b>SELECT</b> key	→ <b>Imbal Xout 4608</b> Counter reading for Imbalance in X-direction 4608 = 0g
8. Press the <b>SELECT</b> key	→ <b>Imbal Yout 4608</b> Counter reading for Imbalance in Y-direction 4608 = 0g

Action	Display / Comment
9. Press the <b>SELECT</b> key	→ <b>Speed RPM 0</b> Function test of the speed sensor (B4) on top of the motor
<ul style="list-style-type: none"> <li>• Turn the rotor by hand</li> </ul>	→ <b>Speed RPM XXX</b> Speeds ≥100 RPM will be displayed
10. Press the <b>SELECT</b> key	→ <b>LED 0 on</b> All light emitting diodes (LED) in the keys are off
<ul style="list-style-type: none"> <li>• Turn the control knob  one step to the right</li> </ul>	→ <b>LED 1 on</b> LED in the <b>START / IMPULS</b> key lights up
<ul style="list-style-type: none"> <li>• Turn the control knob  one step to the right</li> </ul>	→ <b>LED 2 on</b> Left LED in the <b>STOP / OPEN</b> key lights up
<ul style="list-style-type: none"> <li>• Turn the control knob  one step to the right</li> </ul>	→ <b>LED 3 on</b> Right LED in the <b>STOP / OPEN</b> key lights up
11. Press the <b>SELECT</b> key	→ <b>Press any Key</b> Press the keys on the operating panel successively
12. Press the  key	→ <b>Key FastCool</b>  key functions
13. Press the <b>RCF</b> key	→ <b>Key RCF/RPM</b> <b>RCF</b> key functions
14. Press the <b>SELECT</b> key	→ <b>Key Select</b> <b>SELECT</b> key functions
15. Press the <b>START / IMPULS</b> key	→ <b>Key Start</b> <b>START / IMPULS</b> key functions
16. Press the <b>STOP / OPEN</b> key	→ <b>Key Stop</b> Is briefly displayed. <b>STOP / OPEN</b> key functions
	→ <b>*** o.k. ***</b> Is briefly displayed. Appears only if all 5 keys on the operating panel were pressed and have function.
	→ <b>ERROR LED OFF</b> The yellow error LED of the control-processor is located on the Electronics U320 (A1)

Action	Display / Comment
<ul style="list-style-type: none"> <li>Turn the control knob <math>\odot</math> one step to the right</li> </ul>	→ <b>ERROR LED ON</b> The yellow error LED lights up
17. Press the <b>SELECT</b> key	→ <b>SOUND / BELL OFF</b>
<ul style="list-style-type: none"> <li>Turn the control knob <math>\odot</math> one step to the right</li> </ul>	→ <b>SOUND / BELL ON</b> The acoustic beeper on the operating panel will be activated
18. Press the <b>SELECT</b> key	→ <b>CLOSURE MOT. OFF</b>
<ul style="list-style-type: none"> <li>Turn the control knob <math>\odot</math> one step to the right</li> </ul>	→ <b>CLOSURE MOT. ON</b> The motor of the lid lock will be activated
19. Press the <b>SELECT</b> key	→ <b>ADC 0 = 2949 mV</b> Voltage of the temperature sensor on the condenser. 2980 mV ~ 25°C, voltage change 10 mV/K
<ul style="list-style-type: none"> <li>Turn the control knob <math>\odot</math> one step to the right</li> </ul>	→ <b>ADC 1 = 2949 mV</b> Voltage of the temperature sensor in the centrifuge chamber. 2980 mV ~ 25°C, voltage change 10 mV/K
<ul style="list-style-type: none"> <li>Turn the control knob <math>\odot</math> one step to the right</li> </ul>	→ <b>ADC 2 = 4960 mV</b> $\odot$ STOP / OPEN $\odot$ key pressed ~0 mV, otherwise >4900 mV
<ul style="list-style-type: none"> <li>Turn the control knob <math>\odot</math> one step to the right</li> </ul>	→ <b>ADC 3 = 4956 mV</b> Lid lock, motor end switch (A3 / S3): Switch actuated (lid open) <250 mV, Switch not actuated (lid closed) >4900 mV
<ul style="list-style-type: none"> <li>Turn the control knob <math>\odot</math> one step to the right</li> </ul>	→ <b>ADC 4 = 4956 mV</b> Lid lock, motor end switch (A3 / S2): Switch actuated (lid closed) <250 mV, Switch not actuated (lid open) >4900 mV
<ul style="list-style-type: none"> <li>Turn the control knob <math>\odot</math> one step to the right</li> </ul>	→ <b>ADC 5 = 4956 mV</b> Lid lock, left lid switch (S2): Switch actuated (lid closed) <600 mV, Switch not actuated (lid open) >4900 mV
<ul style="list-style-type: none"> <li>Turn the control knob <math>\odot</math> one step to the right</li> </ul>	→ <b>ADC 6 = 1225 mV</b> Temperature value of the imbalance sensor (T <sub>out</sub> ) 1250 mV ~ 25°C

Action	Display / Comment
<ul style="list-style-type: none"> <li>Turn the control knob  one step to the right</li> </ul>	→ <b>ADC 7 = 4956 mV</b> Lid lock, right lid switch (A3 / S1): Switch actuated (lid closed) <600 mV, Switch not actuated (lid open) >4900 mV
20. Press the <b>SELECT</b> key	→ <b>FU Status 2F00</b> Status of the frequency converter. Display 2F00 = ok (Parameter 648)
21. Press the <b>SELECT</b> key	→ <b>Mains Sync ----</b> The mains frequency is measured → <b>Mains Sync 50</b> The actual mains frequency will be displayed
22. Press the <b>SELECT</b> key	→ <b>COOLING UNIT OFF</b> Function test of the compressor → <b>COOLING UNIT ON</b>  <b>Caution!</b> The fan is <u>not</u> working and the temperature of the condenser will not be checked! Do not switch on the compressor longer than 5 seconds. The time between switching off and switching on the compressor again <u>must</u> be minimum 1 minute!
23. Press the <b>SELECT</b> key	→ <b>COOLING FAN 0</b> Function test of the fan at the condenser → <b>COOLING FAN 1-31</b> Speed settable in steps from 1 to 31 (per step = 5° of the sine)
<ul style="list-style-type: none"> <li>Turn the control knob  one step to the right</li> </ul>	→ <b>COOLING FAN 1-31</b> Speed settable in steps from 1 to 31 (per step = 5° of the sine)
24. Press the <b>SELECT</b> key	→ <b>* TEST MODE *</b> Begin of the Test Mode
25. Press the <b>STOP / OPEN</b> key	→ <b>*** exit ***</b> The function test will be terminated

### 6.7 Logging the occurred faults



The data of the two last occurred faults are stored and can be queried.



The inquiry of the operating hours is only possible if the rotor is at standstill. It is at any time possible to terminate the procedure by pressing the **STOP / OPEN** key.

Action	Display / Comment
1. Switch on the mains switch	→ <b>UNI 320R Vx.xx</b> Machine type and program version
	→ <b># 30 4000 01:00</b> Display of the centrifugation data
2. Keep the <b>SELECT</b> key pressed for 8 seconds	→ <b>PROG RCL = X</b>
Display after 8 seconds	→ <b>SOUND / BELL XXX</b>
3. Press the <b>SELECT</b> key <b>so often</b> until the following will be displayed	→ <b>E1 ERROR X</b> E1 = Fault memory 1: last occurred fault
	Values of the parameters when the fault had occurred (hexadecimal values):
• Turn the control knob <b>0</b> to the right	→ <b>E1 PROG X</b> Program number
	→ <b>E1 MIN XX</b> Minutes display of the expired time
	→ <b>E1 SEK XX</b> Seconds display of the expired time
	→ <b>E1 RPM XXXX</b> Speed
	→ <b>E1 HOURS XX</b> Internal operating hours



Action	Display / Comment
<ul style="list-style-type: none"> <li>Turn the control knob  to the right</li> </ul>	<ul style="list-style-type: none"> <li>→ <b>E1 IMB_X        XX</b> Imbalance actual value X</li> <li>→ <b>E1 IMB_Y        XX</b> Imbalance actual value Y</li> <li>→ <b>E1 MAX_X        XX</b> Imbalance maximum value X</li> <li>→ <b>E1 MAX_Y        XX</b> Imbalance maximum value X</li> <li>→ <b>E1 T_MOT        XXXX</b> Temperature value of the imbalance sensor (T<sub>out</sub>)</li> <li>→ <b>E1 T_REAL        XXX</b> Temperature in the centrifuge chamber</li> <li>→ <b>E1 T_KOND        XXX</b> Temperature on the condenser</li> <li>→ <b>E1 FLAGS XXXXXXX</b> Display of the status-flags</li> <li>→ <b>E1 FU_210        XX</b> Temperature of the frequency converter</li> <li>→ <b>E1 FU_219        XXXX</b> Speed (speed sensor at the bottom of the motor)</li> <li>→ <b>E1 FU_630        XXXX</b> Intermediate circuit voltage</li> <li>→ <b>E1 FU_648        XXXX</b> Status of the frequency converter</li> </ul>
<p>4. Press the <b>SELECT</b> key</p>	<p>→ <b>E2 ERROR    XX</b> E2 = Fault memory 2: next-to-last occurred fault</p>
<ul style="list-style-type: none"> <li>Turn the control knob  to the right</li> </ul>	<p>→ <b>E2 PROG        X</b> Selectable parameters see preceding step</p>
<p>5. Press the <b>STOP / OPEN</b> key</p>	<p>The menu will be terminated</p>

### 6.8 Checking the motor slippage

The centrifuge control can readjust the speed depending on the rotor. The error (N < MIN) is displayed if the rotor speed is lower than the permitted range of control.



It is only possible to check the slippage during a centrifugation run.

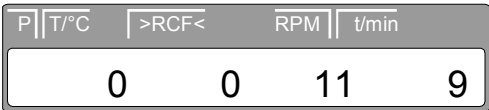
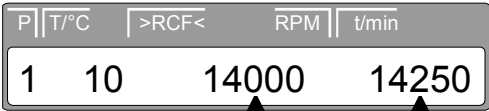



Action	Display / Comment
1. Switch on the mains switch	<p>→ <b>UNI 320R Vx.xx</b> Machine type and program version</p> <p>→ <b># 30 4000 01:00</b> Display of the centrifugation data</p>
2. Start a centrifugation run	<p>Wait until the set speed is achieved</p> <p> The RPM-display must be selected</p>
3. Keep the <b>SELECT</b> key pressed for 8 seconds	<p>→ <b>t/min = XX:XX</b></p>
Display after 8 seconds	<p>→ </p> <p>The imbalance values will be displayed</p>
4. Release the <b>SELECT</b> key again	<p>→ </p> <p style="text-align: center;">Rotor speed                      Field speed</p> <p>The slippage will be displayed</p> <p>Slippage = (field speed) - (rotor speed)</p> <p>The slippage display automatically disappears after 8 seconds.</p>



## 6.9 Parameter interrogation



The inquiry of the parameters is only possible if the rotor is at standstill.



It is at any time possible to terminate the procedure by pressing the  key.

Action	Display / Comment
1. Switch on the mains switch	→ <b>UNI 320R Vx.xx</b> Machine type and program version
	→ <b># 30 4000 01:00</b> Display of the centrifugation data
2. Keep the  key pressed for 8 seconds	→ <b>PROG RCL = X</b>
Display after 8 seconds	→ <b>SOUND / BELL XXX</b> Acoustic signal
3. Press the  key <b>so often</b> until the following will be displayed	→ <b>FU/CCI -S. X.XX</b> Program version of the frequency converter
4. Press the  key <b>so often</b> until the following will be displayed	→ <b>HOURS           XXX</b> Internal operating hours (the time, which the centrifuge was switched on)
	Parameters (hexadecimal values):
• Turn the control knob  to the right	→ <b>STARTS           XXX</b> Number of the centrifugation runs
	→ <b>ROTORCHG1    XX</b> Internal operating hour of the last rotor change
	→ <b>ROTORCHG2    XX</b> Internal operating hour of the next-to-last rotor change
	→ <b>OPhoursCHG XXXXX</b> Internal operating hour of the last change of the operating hours

Action	Display / Comment
<ul style="list-style-type: none"> <li>Turn the control knob  to the right</li> </ul>	→ <b>IMBALCHG      XX</b> Internal operating hour of the last change of the imbalance switch-off
	→ <b>OffsetCHG      XX</b> Internal operating hour of the last offset compensation
5. Press the  key	The menu will be terminated automatically

### 6.10 Display of the frequency converter temperature and the measured speeds

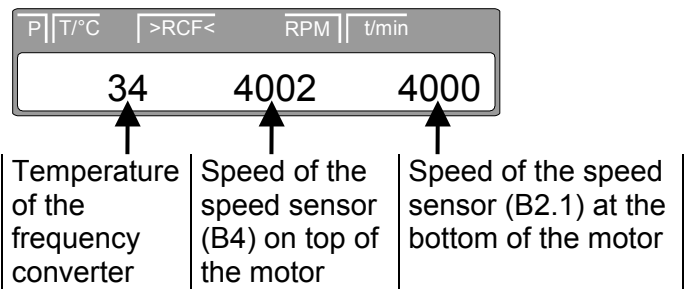
 The inquiry of the temperature and the speeds is possible during the centrifugation run or if the rotor is at standstill.

Action	Display / Comment
1. Keep the  key pressed for 8 seconds	→ <b># 30 4000 01:00</b> Display of the centrifugation data
Display after 8 seconds	→  The temperature and the speeds appear only as long as the  key is kept pressed
2. Release the  key again	→ <b># 30 4000 01:30</b> Display of the centrifugation data

## 6.11 Imbalance values

### 6.11.1 Setting the imbalance switch-off



A change of the imbalance switch-off affects all rotors.

The imbalance switch-off is specified by the indication of the difference in weight of opposite rotor positions.

In the factory the imbalance switch-off will be adjusted with rotor 1494.

With swing-out rotors all rotor positions must be lined with **identical** hangers.

By a test run with empty rotor, and that for the rotor specified switch-off weight in one rotor place the imbalance switch-off is checked, see following table.



With the switch-off weight specified for the rotor the drive must absolutely switch off during the run-up.

#### Switch-off weights of the different rotors:

Rotor	Switch-off weight
1324	15 g
1399	10 g
1418	14 g
1420	9 g
1460	20 g
1494	15 g
1611	13 g
1612	10 g
1613	12 g
1615	14 g
1617	15 g
1619	13 g
1620A	12 g
1622	21 g
1624	15 g
1626	16 g
1628	16 g
1645	12 g
1648	20 g
1650	6 g
1689	9 g
SK 26.02-3	16 g



The setting of the imbalance switch-off is only possible if the rotor is at standstill.

It is at any time possible to terminate the procedure by pressing the **STOP / OPEN** key twice.

Action	Display / Comment
1. Switch on the mains switch	→ <b>UNI 320R Vx.xx</b> Machine type and program version
2. While <b>UNI 320R Vx.xx</b> is displayed, keep the <b>START / IMPULS</b> key and the <b>STOP / OPEN</b> key pressed simultaneously for 16 seconds	→ <b>* SELECT MODE *</b>  If <b>KEYBOARD-ERROR</b> will be displayed, a key was briefly released. The entire procedure must be carried out again.
3. Press the <b>SELECT</b> key <b>so often</b> until the following will be displayed	→ <b>GOTO SETUP</b>
4. Press the <b>START / IMPULS</b> key	→ <b>* SETUP-MODE *</b>
5. Press the <b>SELECT</b> key <b>so often</b> until the following will be displayed	→ <b>IMBALANCE = XXX</b> Adjusted value of the imbalance switch-off
<ul style="list-style-type: none"> <li>• Turn the control knob </li> </ul>	→ <b>IMBALANCE = XXX</b> The imbalance switch-off can be readjusted in increments of 1 within the range $\pm 30$ .  Increase the value: Switch-off takes place with a higher weight  Decrease the value: Switch-off takes place with a lower weight
6. Press the <b>START / IMPULS</b> key	→ <b>*** ok ***</b> The setting will be stored. The menu will be terminated automatically.

### 6.11.2 Imbalance values of the last centrifugation run



The inquiry of the imbalance values of the last centrifugation run is only possible if the rotor is at standstill.

It is at any time possible to terminate the procedure by pressing the **STOP / OPEN** key.

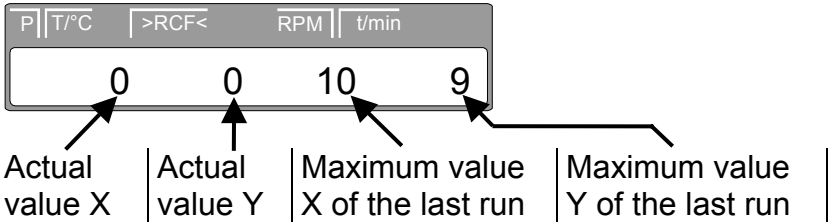
Action	Display / Comment
1. Switch on the mains switch	→ <b>UNI 320R Vx.xx</b> Machine type and program version
	→ <b># 30 4000 01:00</b> Display of the centrifugation data
2. Keep the <b>SELECT</b> key pressed for 16 seconds	→ <b>PROG RCL = X</b>
Display after 8 seconds	→ <b>SOUND / BELL XXX</b>
Display after 16 seconds	→ 
3. Press the <b>STOP / OPEN</b> key or press no key for a period of 16 seconds	→ <b># 30 4000 01:00</b> Display of the centrifugation data

### 6.11.3 Imbalance values during centrifugation run

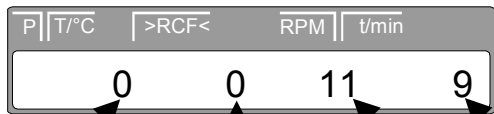
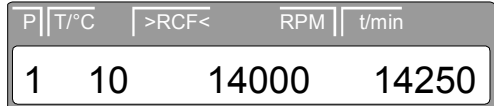
Action	Display / Comment				
1. Switch on the mains switch	<p>→ <b>UNI 320R Vx.xx</b> Machine type and program version</p> <p>→ <b># 30 4000 01:00</b> Display of the centrifugation data</p>				
2. Start a centrifugation run	Wait until the set speed is achieved				
3. Keep the <b>(SELECT)</b> key pressed for 8 seconds	→ <b>t/min = XX:XX</b>				
Display after 8 seconds	<p>→</p>  <table border="1" data-bbox="555 1021 1385 1099"> <tr> <td>Actual value X</td> <td>Actual value Y</td> <td>Maximum value X of the actual run</td> <td>Maximum value Y of the actual run</td> </tr> </table> <p>The imbalance values appear only as long as the <b>(SELECT)</b> key is kept pressed</p>	Actual value X	Actual value Y	Maximum value X of the actual run	Maximum value Y of the actual run
Actual value X	Actual value Y	Maximum value X of the actual run	Maximum value Y of the actual run		
4. Release the <b>(SELECT)</b> key again	<p>→</p>  <p>The motor slippage will be displayed for 8 seconds, see chapter "Checking the motor slippage". Then the menu will be terminated automatically.</p>				



## 6.12 Cooling parameters

### 6.12.1 Switch-on delay of the Standby cooling



After a centrifugation run the standby cooling takes place time-delayed.  
The delay time is preset to 1 minute.



The delay time can only be set, if the rotor is at standstill and the lid is opened.

It is at any time possible to terminate the procedure by pressing the **STOP / OPEN** key.

If no key is pressed for a period of 8 seconds the menu will be terminated automatically.

Action	Display / Comment
1. Switch on the mains switch	→ <b>UNI 320R Vx.xx</b> Machine type and program version
	→ <b># 30 4000 01:00</b> Display of the centrifugation data
2. Keep the  key pressed for 8 seconds	→ <b># 30 4000 01:00</b>
Display after 8 seconds	→ <b>t/min = X</b> Delay time of the standby cooling
• Turn the control knob 	→ <b>t/min = X</b> Set the delay time. The delay time is settable from 1 to 5 minutes, in 1 minute increments.
3. Press the <b>START / IMPULS</b> key	→ <b>*** ok ***</b> The setting will be stored. The menu will be terminated automatically.

### 6.12.2 Pre-cooling speed

The pre-cooling speed is preset to 2800 RPM.



The pre-cooling speed can only be set, if the rotor is at standstill and the lid is opened.

It is at any time possible to terminate the procedure by pressing the **STOP / OPEN** key.

If no key is pressed for a period of 8 seconds the menu will be terminated automatically.

Action	Display / Comment
1. Switch on the mains switch	→ <b>UNI 320R Vx.xx</b> Machine type and program version
	→ <b># 30 4000 01:00</b> Display of the centrifugation data
2. Keep the <b>STOP</b> key pressed for 8 seconds	→ <b># 30 4000 01:00</b>
Display after 8 seconds	→ <b>t/min = X</b> Delay time of the standby cooling
3. Press the <b>STOP</b> key	→ <b>RPM = XXXX</b> Pre-cooling speed
• Turn the control knob <b>0</b>	→ <b>RPM = XXXX</b> Set the pre-cooling speed. The pre-cooling speed can be adjusted in decadic steps from 500 RPM to the max RPM of the rotor.
4. Press the <b>START / IMPULS</b> key	→ <b>*** ok ***</b> The setting will be stored. The menu will be terminated automatically.

### 6.12.3 Temperature values during standstill

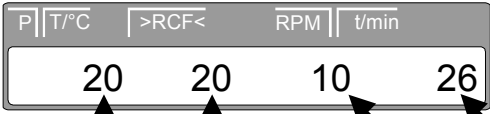
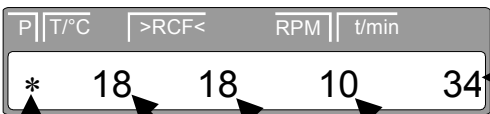

The inquiry of the temperature values is only possible if the lid is opened. It is at any time possible to terminate the procedure by pressing the **STOP / OPEN** key.

Action	Display / Comment										
1. Switch on the mains switch	<p>→ <b>UNI 320R Vx.xx</b> Machine type and program version</p> <p>→ <b># 30 4000 01:00</b> Display of the centrifugation data</p>										
2. Keep the  key pressed for 16 seconds	→ <b># 30 4000 01:00</b>										
Display after 8 seconds	→ <b>t/min = X</b>										
Display after 16 seconds	<p>→ </p> <table border="1" style="width: 100%; border-collapse: collapse; margin-top: 5px;"> <tr> <td style="width: 25%; text-align: center;">↑</td> <td style="width: 25%; text-align: center;">↑</td> <td style="width: 25%; text-align: center;">↑</td> <td style="width: 25%; text-align: center;">↑</td> </tr> <tr> <td style="text-align: center;">Tempera- ture value in the display</td> <td style="text-align: center;">Temperature value of temperature sensor in the centrifuge chamber</td> <td style="text-align: center;">Temperature set value</td> <td style="text-align: center;">Temperature value of tem- perature sensor on condenser</td> </tr> </table>	↑	↑	↑	↑	Tempera- ture value in the display	Temperature value of temperature sensor in the centrifuge chamber	Temperature set value	Temperature value of tem- perature sensor on condenser		
↑	↑	↑	↑								
Tempera- ture value in the display	Temperature value of temperature sensor in the centrifuge chamber	Temperature set value	Temperature value of tem- perature sensor on condenser								
3. Close the lid	<p>→ </p> <table border="1" style="width: 100%; border-collapse: collapse; margin-top: 5px;"> <tr> <td style="width: 20%; text-align: center;">↑</td> <td style="width: 20%; text-align: center;">↑</td> <td style="width: 20%; text-align: center;">↑</td> <td style="width: 20%; text-align: center;">↑</td> <td style="width: 20%; text-align: center;">↑</td> </tr> <tr> <td style="text-align: center;">* = cool- ing on</td> <td style="text-align: center;">Tem- perature value in the display</td> <td style="text-align: center;">Temperature value of temperature sensor in centrifuge chamber</td> <td style="text-align: center;">Tem- perature set value</td> <td style="text-align: center;">Tempera- ture value of temperature sensor on condenser</td> </tr> </table> <p style="text-align: center; margin-top: 10px;">The temperature values during the standby cooling will be displayed</p>	↑	↑	↑	↑	↑	* = cool- ing on	Tem- perature value in the display	Temperature value of temperature sensor in centrifuge chamber	Tem- perature set value	Tempera- ture value of temperature sensor on condenser
↑	↑	↑	↑	↑							
* = cool- ing on	Tem- perature value in the display	Temperature value of temperature sensor in centrifuge chamber	Tem- perature set value	Tempera- ture value of temperature sensor on condenser							
4. Press the <b>STOP / OPEN</b> key	→ <b># 30 4000 01:00</b> Display of the centrifugation data										

### 6.12.4 Temperature values during centrifugation run

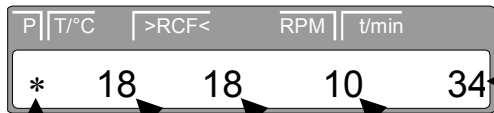

It is at any time possible to terminate the procedure by pressing the **STOP / OPEN** key.

Action	Display / Comment					
1. Switch on the mains switch	→ <b>UNI 320R Vx.xx</b> Machine type and program version					
	→ <b># 30 4000 01:00</b> Display of the centrifugation data					
2. Start a centrifugation run						
3. Keep the  key pressed for 8 seconds	→ <b># 30 4000 01:00</b> Display will not be updated					
Display after 8 seconds	→  <table border="1" data-bbox="555 1182 1385 1406"> <tr> <td>* = cooling on</td> <td>Temperature value in the display</td> <td>Temperature value of temperature sensor in centrifuge chamber</td> <td>Temperature set value</td> <td>Temperature value of temperature sensor on condenser</td> </tr> </table> <p>The temperature values during the centrifugation run will be displayed</p>	* = cooling on	Temperature value in the display	Temperature value of temperature sensor in centrifuge chamber	Temperature set value	Temperature value of temperature sensor on condenser
* = cooling on	Temperature value in the display	Temperature value of temperature sensor in centrifuge chamber	Temperature set value	Temperature value of temperature sensor on condenser		
4. Press the <b>STOP / OPEN</b> key	→ <b># 30 4000 01:00</b> Display of the centrifugation data					
5. Press the <b>STOP / OPEN</b> key	→ <b># 30 4000 01:00</b> Centrifugation run will be stopped					
	→ <b>OPEN OEFFNEN</b> Open the lid					

### 6.12.5 Compensate the temperature sensors

The offset compensation is carried out to correct the measurement deviations of the temperature sensors (T1, T3) and the Electronics U320R (A1).

An OFFSET compensation must be carried out:



- after replacing a temperature sensor
- after replacing the EPROM
- after erasing the EEPROM
- after replacing the Electronics U320R (A1)



In order to prevent measuring errors during the temperature measurement, a constant temperature should be at the temperature sensors during the offset compensation.

It is at any time possible to terminate the procedure by pressing the **STOP / OPEN** key twice.



Action	Display / Comment
1. Switch on the mains switch	→ <b>UNI 320R Vx.xx</b> Machine type and program version
2. While <b>UNI 320R Vx.xx</b> is displayed, keep the <b>START / IMPULS</b> key and the <b>STOP / OPEN</b> key pressed simultaneously for 16 seconds	→ * <b>SELECT MODE</b> *  If <b>KEYBOARD-ERROR</b> will be displayed, a key was briefly released. The entire procedure must be carried out again.
3. Press the <b>SELECT</b> key so often until the following will be displayed.	→ <b>GOTO OFFSET</b>
4. Press the <b>START / IMPULS</b> key	→ * <b>OFFSET-MODE</b> *

Action	Display / Comment
5. Press the <b>SELECT</b> key  <ul style="list-style-type: none"> <li>• Turn the control knob </li> </ul>	→ <b>T1: 22,0C → 22,0C</b> Temperature sensor in the centrifuge chamber   If <b>OPEN LID !!</b> will be displayed, press the <b>STOP / OPEN</b> key.  Measure the temperature with a temperature measuring device at the temperature sensor T1 and set the value. Settable in steps of 0.5° C.
6. Press the <b>SELECT</b> key  <ul style="list-style-type: none"> <li>• Turn the control knob </li> </ul>	→ <b>T3: 22,0C → 22,0C</b> Temperature sensor on condenser  Measure the temperature with a temperature measuring device at the temperature sensor T3 and set the value. Settable in steps of 0.5° C.
7. Press the <b>START / IMPULS</b> key	→ <b>*** ok ***</b> The set temperatures for T1 and T3 will be stored. The menu will be terminated automatically.

### 6.13 Initialise and read out the EEPROM

If necessary the EEPROM can be initialized and read out.

During initializing the following, in the EEPROM stored, parameters will be overwritten with defined values (default values):

Parameter	Default value
Program position (P)	#
Running time (t/min, t/sec)	01:00
Speed (RPM)	1000
Centrifugation radius (RAD/mm)	85
Run up step (  )	9
Brake step (  )	9
Temperature set value (T/°C)	25
Automatic repetition of centrifugation runs	∞ (deactivated)
Rotor coding	0
readout of parameter via I2C-bus	0 (deactivated)

The following parameters will not be overwritten:



- Offset values of the temperature sensors
- Operating hours
- Data of the two last occurred faults
- Setting of the Acoustic signal
- Cooling settings



It is at any time possible to terminate the procedure by pressing the  key twice.

#### Action

#### Display / Comment

- |   |  |
|---|--|
| 1. Switch on the mains switch   | → <b>UNI 320R Vx.xx</b><br>Machine type and program version  |
| 2. While <b>UNI 320R Vx.xx</b> is displayed, keep the  key and the  key pressed simultaneously for 16 seconds | → <b>* SELECT MODE *</b><br> If <b>KEYBOARD-ERROR</b> will be displayed, a key was briefly released.<br>The entire procedure must be carried out again. |

Action	Display / Comment
3. Press the <b>SELECT</b> key so often until the following will be displayed.	→ <b>GOTO EEPROM</b>
4. Press the <b>START / IMPULS</b> key	→ <b>* EEPROM-MODE *</b>
5. Press the <b>SELECT</b> key	→ <b>EEPROM_INIT</b> Now the EEPROM can be initialized or read out. If the EEPROM should not be initialized, but only read out, the next step must be jumped over.
6. Press the <b>START / IMPULS</b> key	→ <b>*** init ***</b> All program positions will be overwritten with defined values → <b>*** ok ***</b> Initialization was accomplished → <b>EEPROM_INIT</b>
7. Press the <b>SELECT</b> key <ul style="list-style-type: none"> <li>• Turn the control knob <math>\odot</math></li> </ul>	→ <b>EEPROM 000 0000</b>  The EEPROM addresses 000 <sub>hex</sub> up to 3FE <sub>hex</sub> can be read out. Always 2 storage locations are indicated at the same time, their values must always be identical.
8. Press the <b>STOP / OPEN</b> key	→ <b>EEPROM-MODE</b>
9. Press the <b>STOP / OPEN</b> key	→ <b>*** exit ***</b> The initialization will be terminated



**6.14 Activate the functions for the operation with an external refrigerating/heating circulator in the programme  
(only for types 1406-50, 1406-51, 1406-70 and 1406-71)**

Units for connecting to an external refrigerating/heating circulator have the following special features:

- After switching on the unit the machine type **UNI 320 TE** will be displayed for a short period.
- No input of the temperature set value is possible at the centrifuge.
- The display of the operating panel shows always the actual value of the temperature.
- The overtemperature switch switches off the drive, when the temperature in the centrifuge chamber is  $>120^{\circ}\text{C}$ .
- A fan is installed for cooling the motor and the electronics.

These functions have to be activated in the programme.



Units for connecting to an external refrigerating/heating circulator are only operative from programme version V1.03.

It is at any time possible to terminate the following procedure by pressing the **STOP / OPEN** key twice.

Action	Display / Comment
1. Switch on the mains switch	→ <b>UNI 320R Vx.xx</b> Machine type and program version
2. While <b>UNI 320R Vx.xx</b> is displayed, keep the <b>START / IMPULS</b> key and the <b>STOP / OPEN</b> key pressed simultaneously for 16 seconds	→ <b>* SELECT MODE *</b>  If <b>KEYBOARD-ERROR</b> will be displayed, a key was briefly released. The entire procedure must be carried out again.
3. Press the <b>SELECT</b> key so often until the following will be displayed	→ <b>GOTO SETUP</b>
4. Press the <b>START / IMPULS</b> key	→ <b>* SETUP-MODE *</b>

Action	Display / Comment
5. Press the <b>(SELECT)</b> key so often until the following will be displayed	→ <b>LABOSTAT OFF</b>
• Turn the control knob 	→ <b>LABOSTAT ON</b> ON = functions for the operation with an external refrigerating/heating circulator activated. OFF = functions for the operation with an external refrigerating/heating circulator deactivated
6. Press the <b>(START / IMPULS)</b> key	→ <b>*** ok ***</b> The setting will be stored
	→ <b>*** exit ***</b> The menu will be terminated automatically

### 6.15 Setting the display contrast

The contrast of the display has been set by the manufacturer. With operating panel E2275 with revision R00 (see label on the printed circuit board) the contrast can be readjust.



Switch of the mains switch and disconnect the centrifuge from the mains supply.

Use a screwdriver with insulated shank to make this setting as there is a risk of short circuit on the printed circuit board.

- Unscrew the 3 screws on the lower part of the front panel.
- Pull the lower part of the front panel forward as far as it can be detached.
- Use the screwdriver to set the contrast on the trimming potentiometer on the rear side of the control panel (see figure).

Rear side of the control panel:

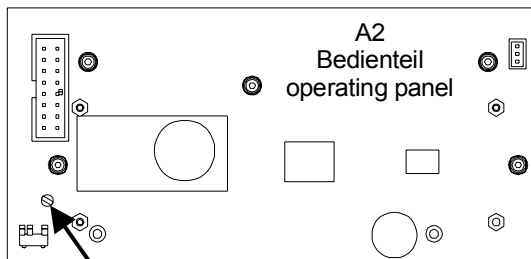

trimming potentiometer for LCD-contrast

- Press the lower part of the front panel against the housing. Then press the upper part of the front panel against the housing until both bolts will snap in.
- Fasten the front panel with the 3 screws again.

## 7 Functional check after a repair

After a repair a functional check of the unit must be carried out.

For functional check a test run with the loaded rotor must be performed.

During the test run the followings must be checked:

- Function of the keys, the display and the LEDs.
- Run-up and slow-down time, max. speed of the rotor. Values see operating instructions chapter "Anhang/Appendix, Rotoren und Zubehör/Rotors and accessories".
- Sample temperature. Values see operating instructions chapter "Anhang/Appendix, Rotoren und Zubehör/Rotors and accessories".
- Imbalance switch-off. Values see repair instructions chapter "Imbalance values".
- Current consumption. Values see repair instructions chapter "Technical specification".

After the test run a safety test must be carried out.

Check the following values:

- Insulation resistance > 2 M $\Omega$
  - Protective conductor resistance < 0.2  $\Omega$
  - Leakage current < 3.5 mA \*
- \* limit according to EN 61010-1

A laboratory centrifuge do not belong to those medical appliances which may be tested according to the regulation IEC 60601-1 or corresponding national medical electronic standards. Laboratory centrifuges are classified as laboratory equipment.

The regulations applying to laboratory equipment are IEC 61010-1 or European standard EN 61010-1.

## 8 General arrangement of the components

Item	Designation
1	Lid
2	Left leg spring
3	Right leg spring
4	Covering sheet UNIVERSAL 320
5	Covering sheet UNIVERSAL 320 R
6	Packing ring
7	Motor cover UNIVERSAL 320
8	Motor cover UNIVERSAL 320 R
9	Folded bellow (only UNIVERSAL 320 R)
10	Front panel UNIVERSAL 320
11	Front panel UNIVERSAL 320 R
12	Rotary knob with flat spring
13	Jog shuttle with cable
14	Operating panel
15	Electronics U320, Electronics U320 R
16	Brake resistor
17	Overtemperature fuse at brake resistor
18	Speed sensor (on top of the motor)
19	Motor
20	Speed/imbalance sensor (at the bottom of the motor)
21	Rubber-metal bearing
22	Upper anti-twist device
23	Lower anti-twist device
24.1	Radio interference suppression filter (only 120 V version)
24.2	Appliance plug with radio interference suppression filter (only 120 V version)
25	Appliance plug
26	ON-OFF switch UNIVERSAL 320
27	ON-OFF switch UNIVERSAL 320 R
28	Compressor (only UNIVERSAL 320 R)
29	Starting relaiy (only UNIVERSAL 320 R)
30	Starting capacitor (only UNIVERSAL 320 R)
31	Fan (only UNIVERSAL 320 R)
32	Temperature sensor in centrifuge chamber (only UNIVERSAL 320 R)
33	Temperature sensor at condenser (only UNIVERSAL 320 R)
34	Ventilation grille
35	Right lid lock complete
36	Gear motor
37	Electronics motor-driven lid lock
38	Eccentric disc
39	Left lid lock complete
40	Tension spring
41	Sliding block

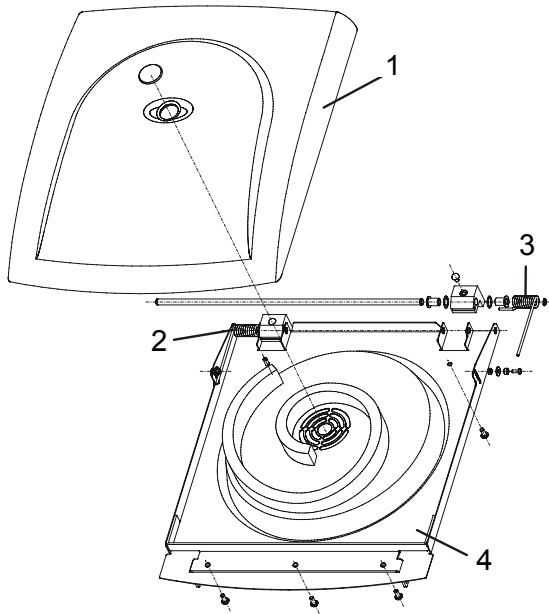

Fig. 1

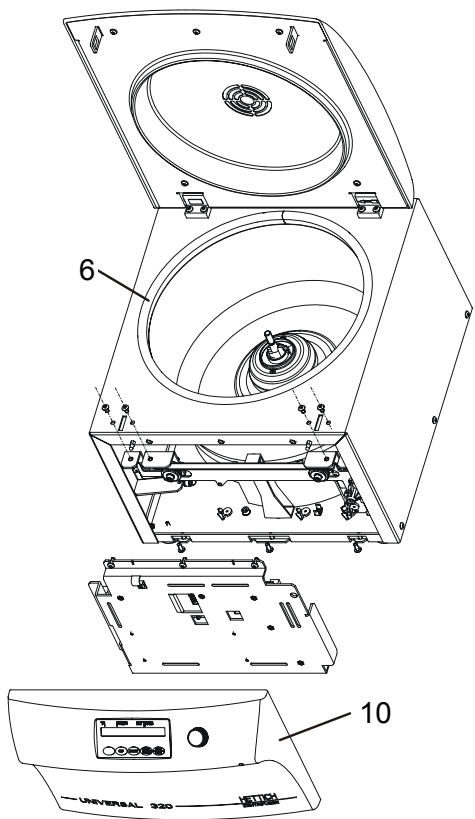

Fig. 2

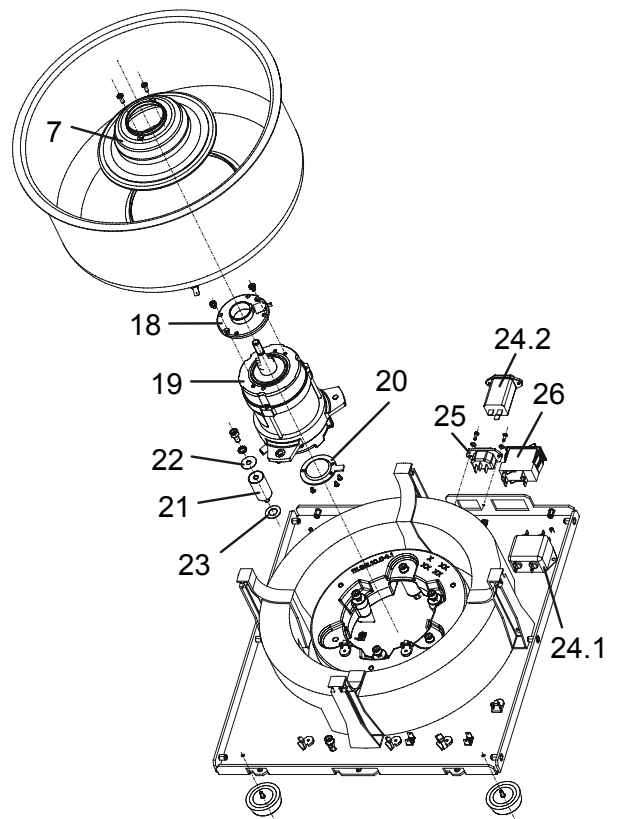

Fig. 3

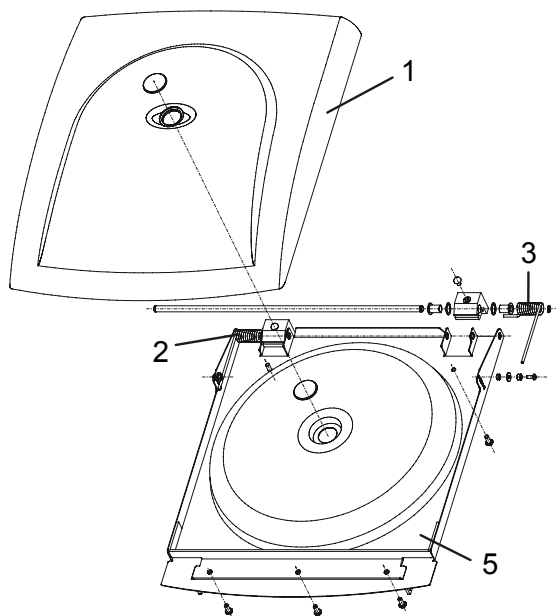

Fig. 4

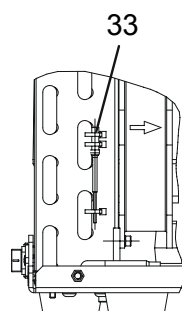

Fig. 5

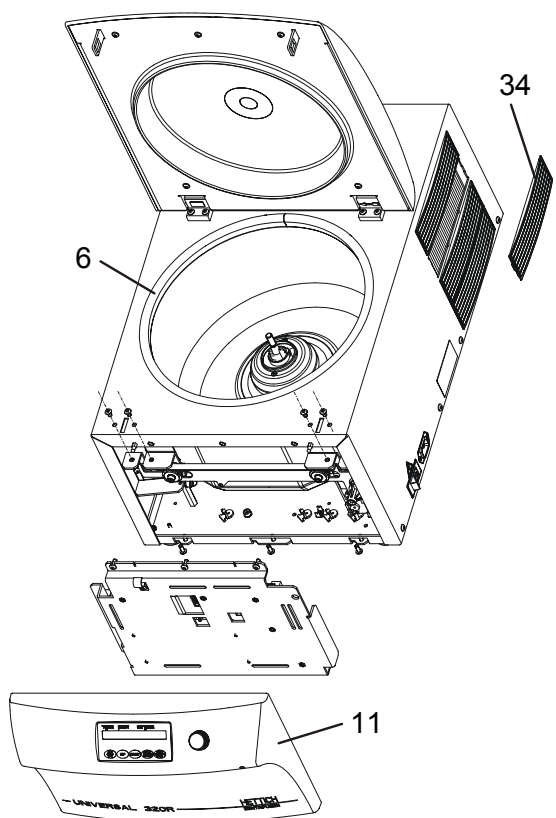

Fig. 6

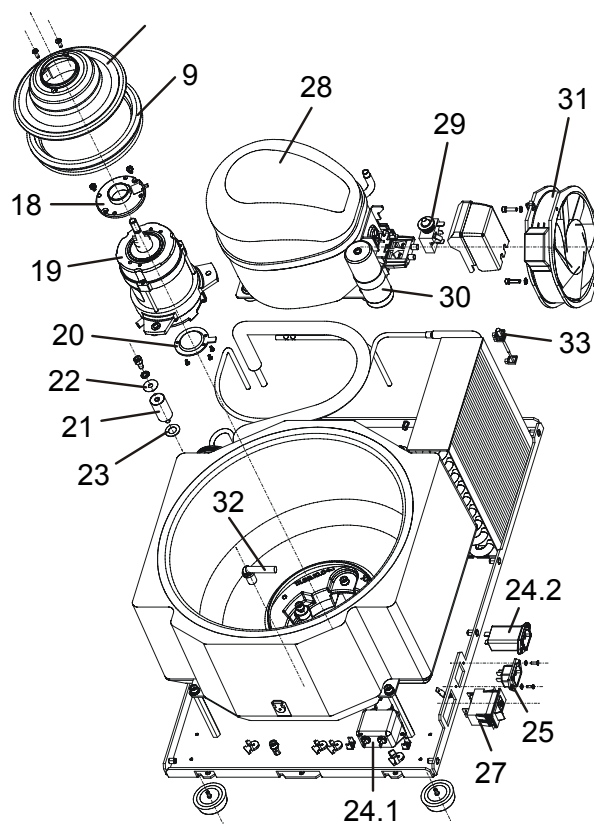

Fig. 7

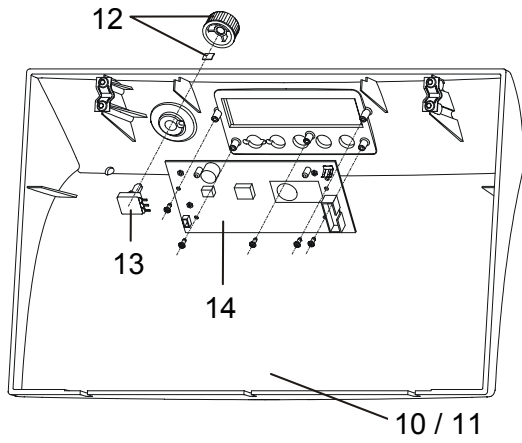

Fig. 8

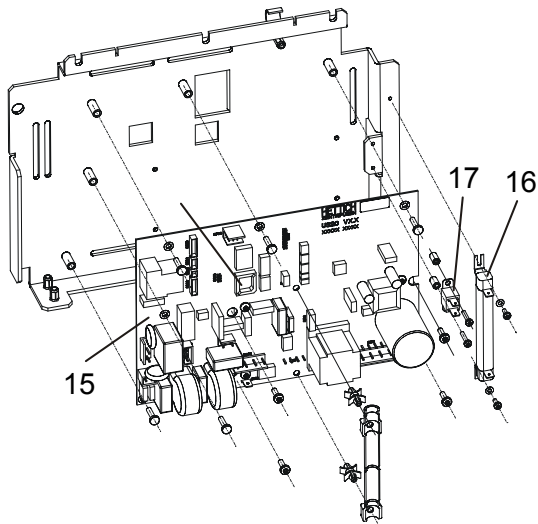

Fig. 9

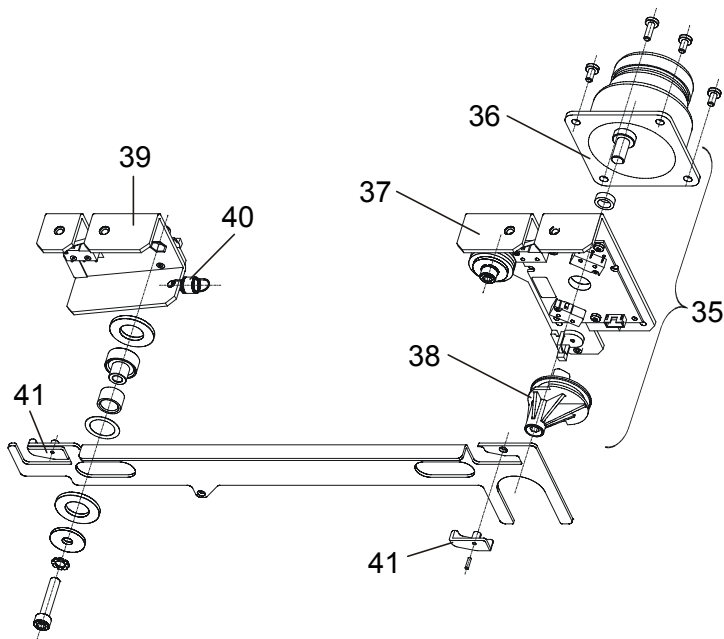
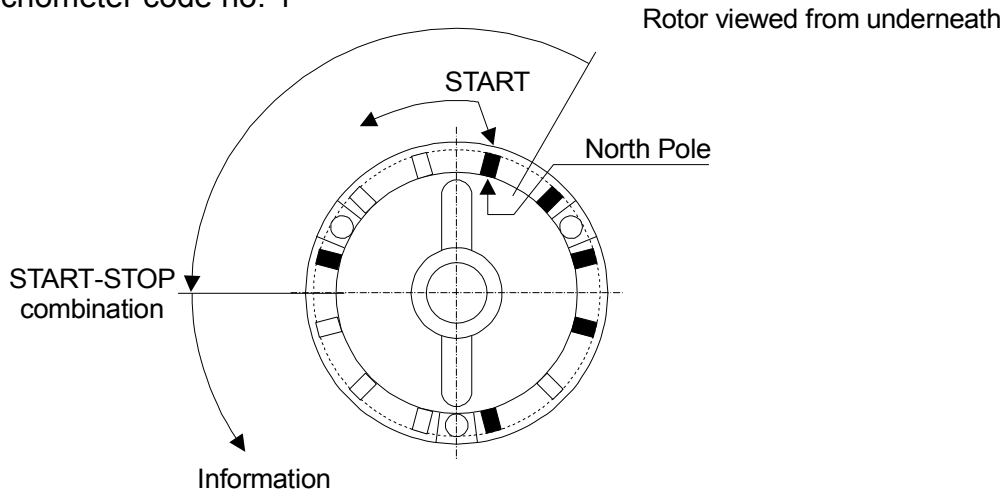

Fig. 10

### 9 Technical documents

#### 9.1 Tachometer code configuration of the rotors

Example: tachometer code no. 1



tachometer code determines: 1. maximum speed of rotor  
2. run up and braking ramps  
3. control response of electronics

e.g. Rotor 1624

1001,00010111

rotor code

Start / Stop combination.

The begin of the Start / Stop combination is marked with a white dot.

0 = no magnet (empty place), 1 = magnet inserted

Tachometer code-no.	Configuration	RPM	Rotor
0	1001 00001111	5000	1494
1	1001 00010111	4000	1611, 1619, 1622, 1624, 1626
2	1001 00011011	5000	1628
3	1001 00011101	6000	1613
4	1001 00011110	9000	1620A
5	1001 01000111	12000	1615
6	1001 01010101	14000	1689
7	1001 01010110	15000	1612, 1420
8	1001 01011010	4000	1460, 1645, 1648
9	1001 01100011	15000	1650
10	1001 01110001	19800	E778-01
11	1001 10000111	4000	1399
12	1001 10001011	5000	1617
13	1001 10001101	2000	SK 26.02-3
14	1001 10100011	4500	1324, 1418
15	1001 11000011	500	---



9.2 Cooling diagram

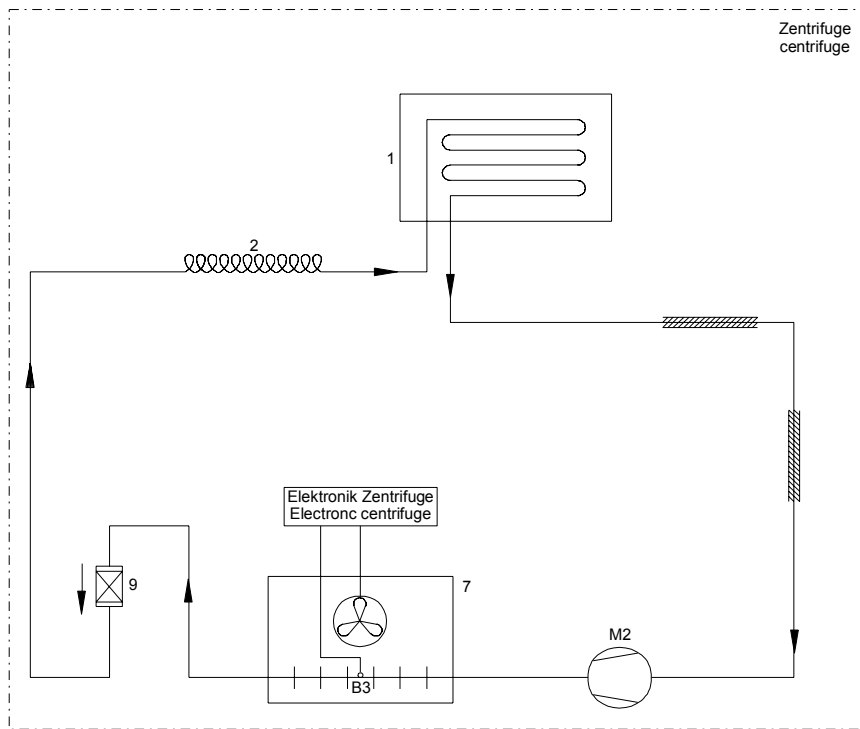

1	Evaporator (centrifuge chamber)
2	Capillary tube
7	Air-cooled condenser
9	Filter dryer (flow direction vertical from top to bottom !!!)
B3	Temperature sensor on condenser (controlled by centrifuge electronics)
M2	Compressor

- BLANK PAGE -

### 9.3 Connecting diagram

#### 9.3.1 Abbreviations of the cable colours

Abbreviation	Colour
BK	black
BN	brown
BU	blue
GD	gold
GN	green
GNYE	green-yellow
GY	grey
OG	orange
PK	pink
RD	red
SR	silver
TQ	turquoise
Transp.	transparent
VT	violet
WH	white
YE	yellow

#### 9.3.2 Connecting diagram mains input UNIVERSAL 320 / 320 R

Only in devices manufactured before October 2008.

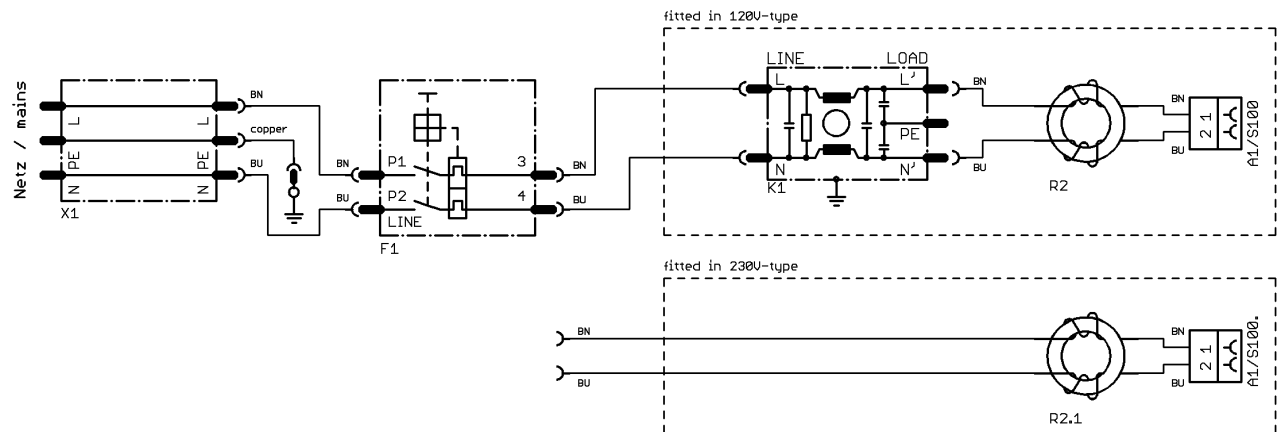

F1	Geräteschutzschalter	unit protection switch
K1	Funkentstörfilter	radio interference suppression filter
R2/R2.1	Entstördrossel	interference coil
X1	Gerätestecker	appliance plug

Rev.: 00

### 9.3.3 Connecting diagram UNIVERSAL 320 / 320 R

1401, 1401-01, 1401-14, 1401-15, 1406, 1406-01, 1406-20, 1406-21

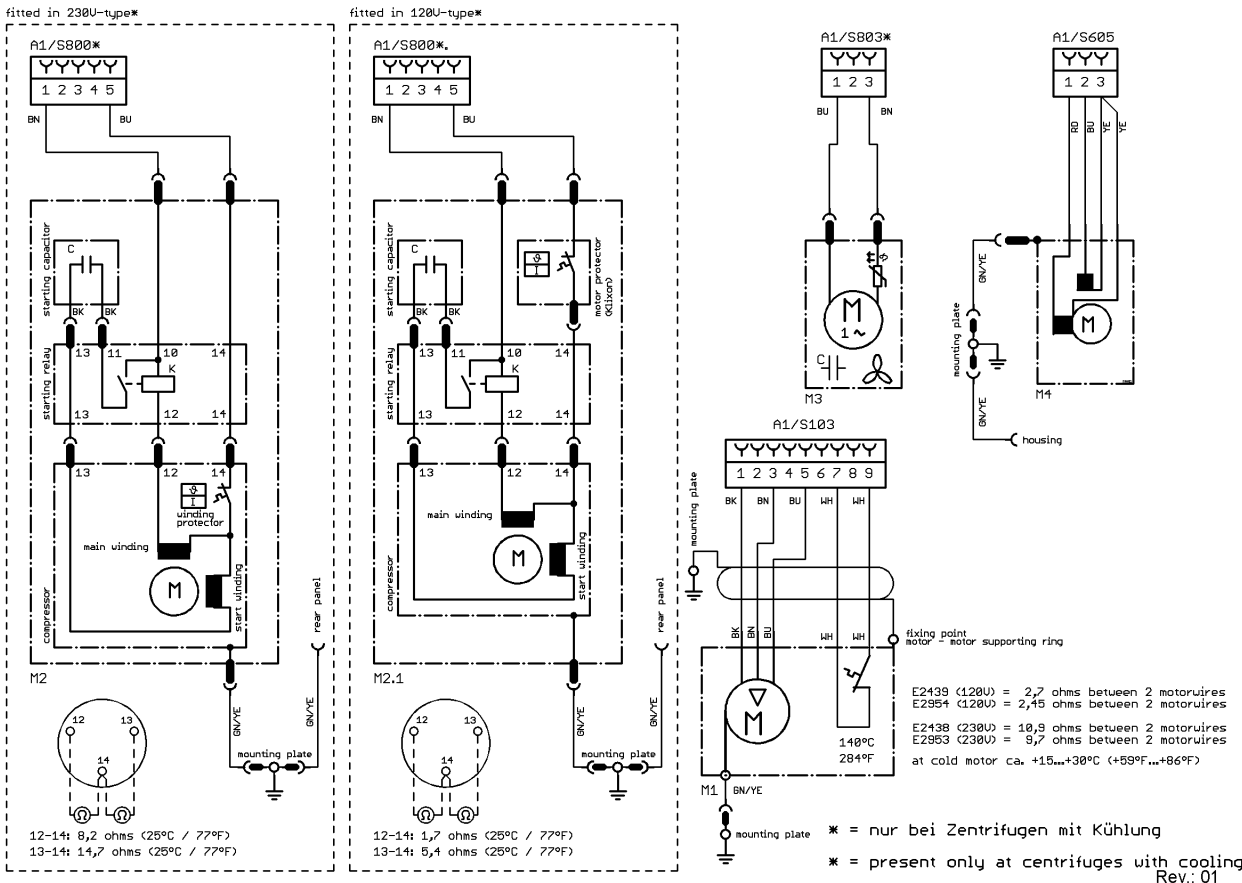
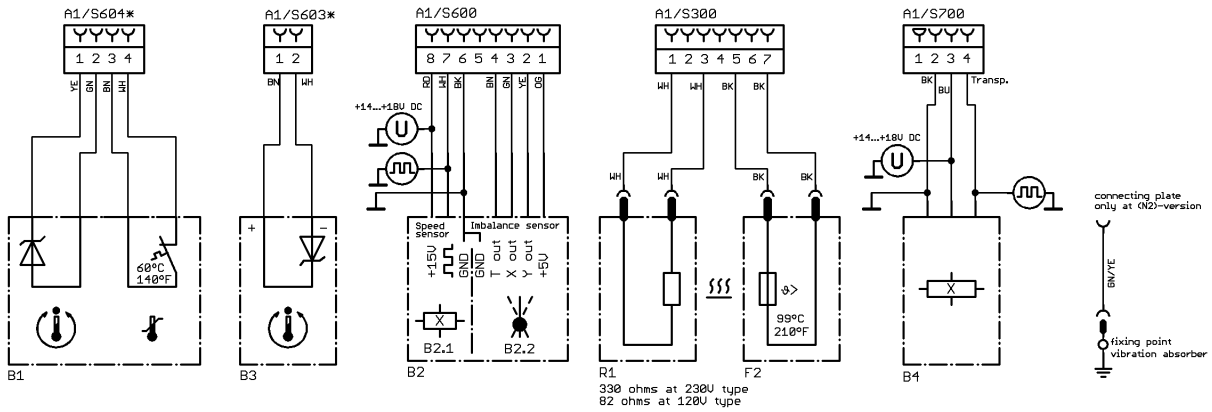
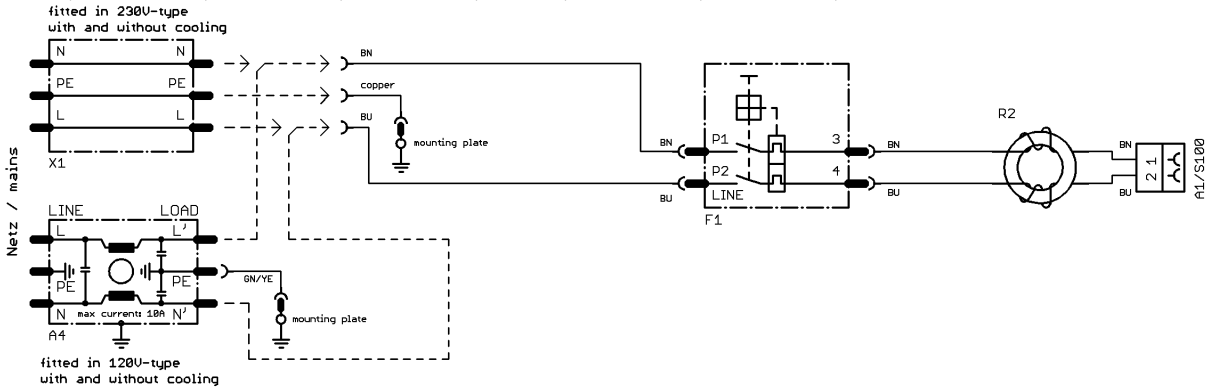

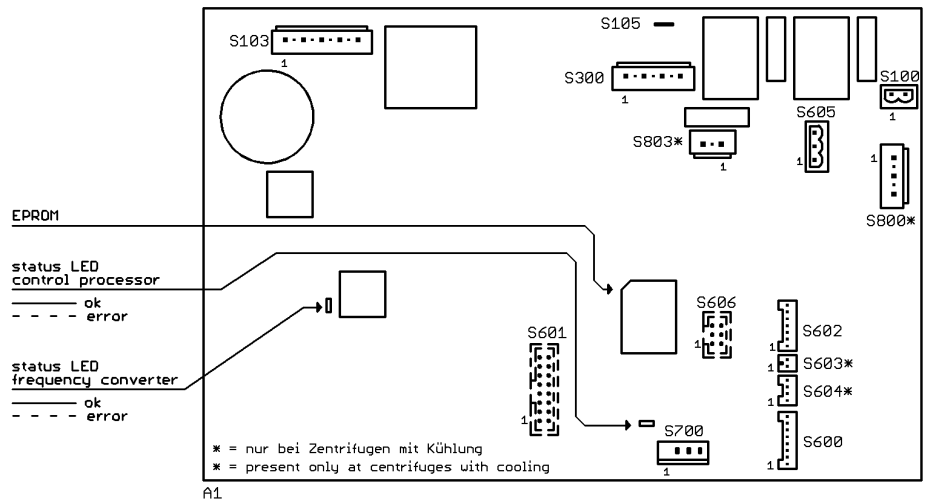
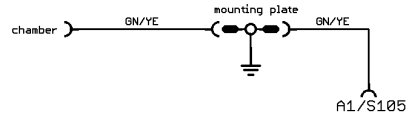
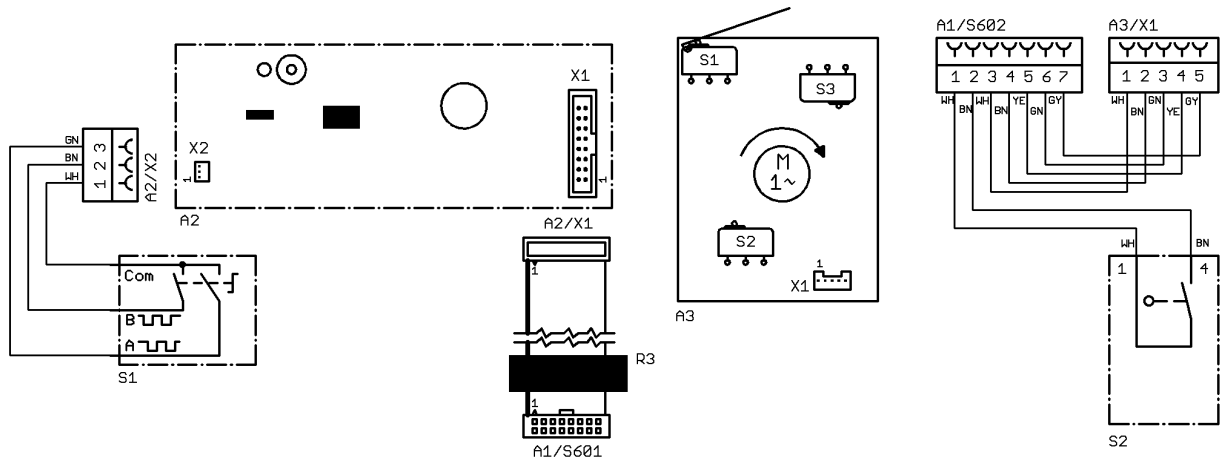

A1	Elektronik U320 / U320R	electronic U320 / U320R
A2	Bedienteil	control panel
A3	motorischer Deckelverschluss	motor driven lid locking
A4	Gerätestecker mit Funkenstörfilter	appliance plug with radio interference suppression filter
B1	Temperaturfühler / Temperaturschutz am Kesselboden	temperature sensor / overheating protection at chamber bottom in centrifuge chamber
B2	Drehzahlsensor B2.1 / Unuachtsensor B2.2	speed sensor B2.1 / imbalance sensor B2.2
B3	Temperaturfühler am Kondensator	temperature sensor at condenser
B4	Drehzahlsensor / Rotorerkennung	speed sensor / rotor identification
F1	Geräteschutzschalter	unit protection switch
F2	Übertemperaturschutz am Bremswiderstand	overheating protection for braking resistor
M1	Motor der Zentrifuge	motor of centrifuge
M2/M2.1	Verdichter	cooling compressor
M3	Lüfter	fan
M4	Antriebsmotor des motorischen Deckelverschlusses	driving motor of motor driven lid locking
R1	Bremswiderstand	braking resistor
R2	Entstördrossel	interference coil
R3	Entstör-Ferrit Bedienteil A2	interference ferrit (A2 control panel)
S1	Drehimpulsgeber	rotary encoder
S2	Mikroschalter am linken Verschluss	micro switch at left lid lock
X1	Gerätestecker	appliance plug

Rev.: 01

### 9.3.4 Connecting diagram UNIVERSAL 320 R Heating/cooling

#### 1406-50, 1406-51, 1406-70, 1406-71

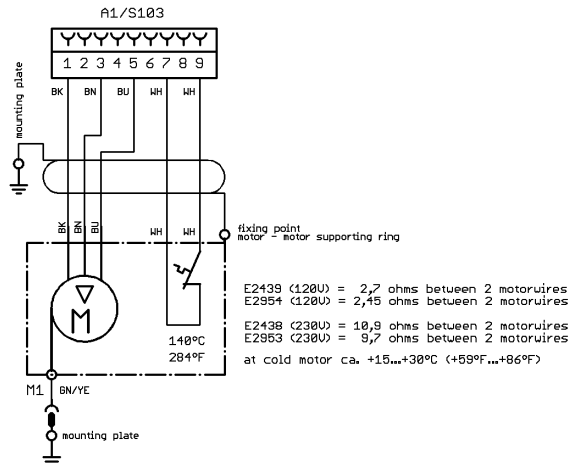
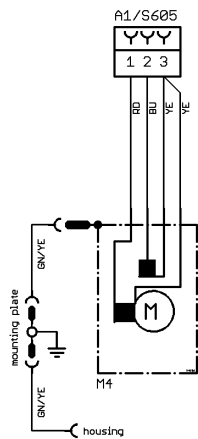
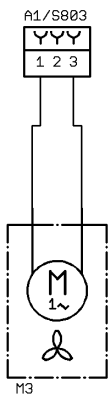
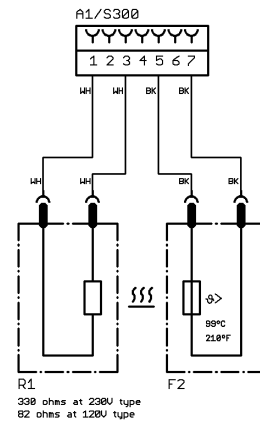
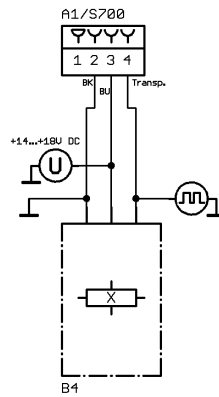
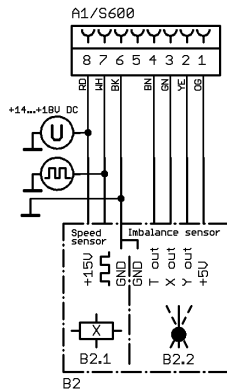
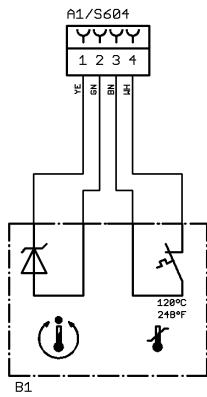
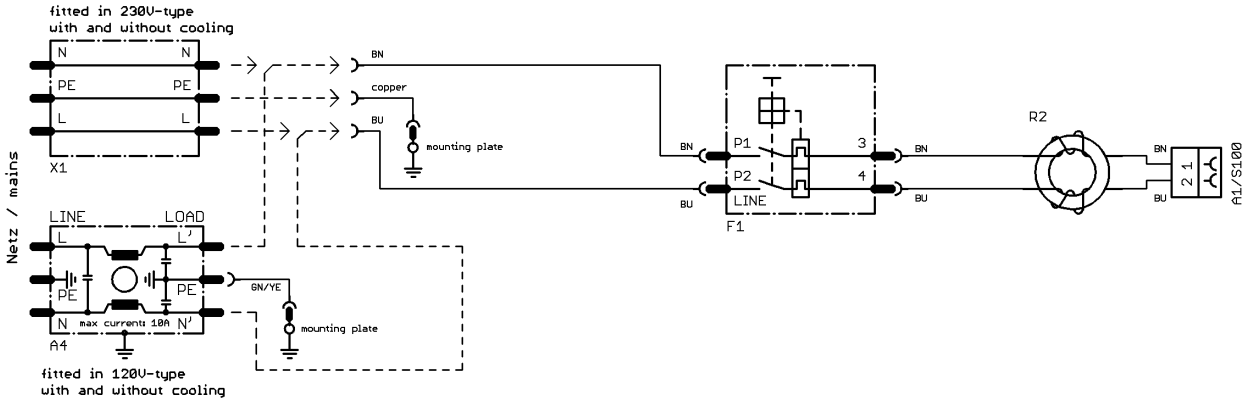

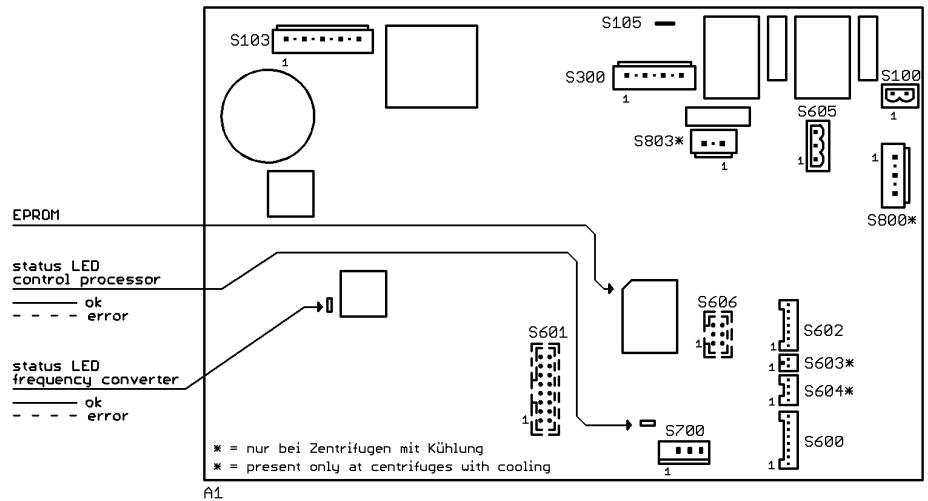
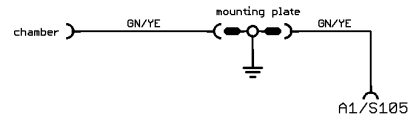
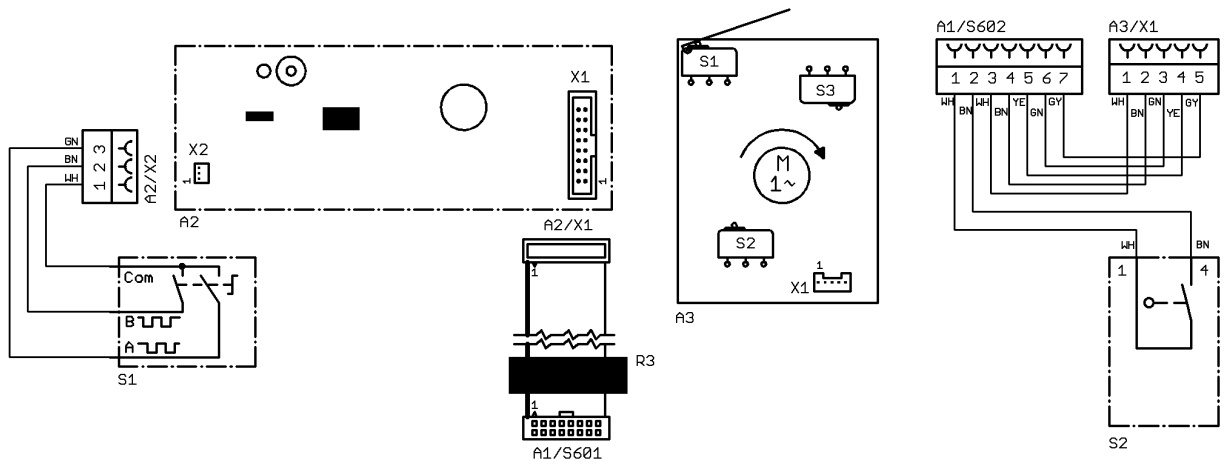

A1	Elektronik U320R	electronic U320R
A2	Bedienteil	control panel
A3	motorischer Deckelverschluss	motor driven lid locking
A4	Gerätestecker mit Funkentstörfilter	appliance plug with radio interference suppression filter
B1	Temperaturfühler / Temperaturschutz am Kesselboden	temperature sensor / overheating protection at chamber bottom
B2	Drehzahlsensor B2.1 / Unwuchtsensor B2.2	speed sensor B2.1 / imbalance sensor B2.2
B4	Drehzahlsensor / Rotorerkennung	speed sensor / rotor identification
F1	Geräteschutzschalter	unit protection switch
F2	Übertemperaturschutz am Bremswiderstand	overheating protection for braking resistor
M1	Motor der Zentrifuge	motor of centrifuge
M3	Lüfter	fan
M4	Antriebsmotor des motorischen Deckelverschlusses	driving motor of motor driven lid locking
R1	Bremswiderstand	braking resistor
R2	Entstördrossel	interference coil
R3	Entstör-Ferrit Bedienteil A2	interference ferrit (A2 control panel)
S1	Drehimpulsgeber	rotary encoder
S2	Mikroschalter am linken Verschluss	micro switch at left lid lock
X1	Gerätestecker Netzeingang	appliance plug

Rev.: 01

## 9.4 Technical specifications

Manufacturer	Andreas Hettich GmbH & Co. KG D-78532 Tuttlingen			
Model	UNIVERSAL 320		UNIVERSAL 320 R	
Type	1401	1401-01	1406	1406-01
Mains voltage ( $\pm 10\%$ )	200-240 V 1~	100-127 V 1~	200-240 V 1~	240 V 1~ 115-127 V 1~
Mains frequency	50 – 60 Hz	50 – 60 Hz	50 Hz	60 Hz 60 Hz
Connected load	400 VA	400 VA	800 VA 950 VA	
Current consumption	2.0 A	4.0 A	4.0 A 8.0 A	
Cooling medium	----		R 404A	
Max. capacity	4 x 100 ml			
Allowed density	1.2 kg/dm <sup>3</sup>			
Speed (RPM)	15000			
Force (RCF)	21382			
Kinetic energy	8600 Nm			
Obligatory inspection (BGR 261)	no			
Ambient conditions (EN 61010-1)	<p>Indoors only Up to 2000 m above sea level</p> <p>2°C to 35°C   5°C to 35°C</p> <p>Maximum relative humidity 80% for temperatures up to 31°C, linearly decreasing to 50% relative humidity at 40°C.</p>			
– Set-up site				
– Altitude				
– Ambient temperature				
– Humidity				
– Excess-voltage category (IEC 60364-4-443)	II			
– Pollution degree	2			
Device protection class	I			
Not suitable for use in explosion-endangered areas.				
EMC				
– Emitted interference (suppression of radio interference)	EN 55011, Group 1, Class B EN 61000-3-2 EN 61000-3-3	FCC Class B	EN 55011, Group 1, Class B EN 61000-3-2 EN 61000-3-3	FCC Class B
– Interference immunity	EN 61000-6-2	----	EN 61000-6-2	----
Noise level (dependent on rotor)	$\leq 68$ dB(A)		$\leq 58$ dB(A)	
Dimensions				
– Width	395 mm		401 mm	
– Depth	520 mm		695 mm	
– Height	346 mm		346 mm	
Weight	approx. 31 kg		approx. 53 kg	approx. 52 kg



Manufacturer	Andreas Hettich GmbH & Co. KG D-78532 Tuttlingen			
Model	UNIVERSAL 320 R			
Type	1406-50	1406-51	1406-70	1406-71
Mains voltage ( $\pm 10\%$ )	200-240 V 1~	100-127 V 1~	200-240 V 1~	100-127 V 1~
Mains frequency	50 – 60 Hz	50 – 60 Hz	50 – 60 Hz	50 – 60 Hz
Connected load	400 VA	400 VA	400 VA	400 VA
Current consumption	2.0 A	4.0 A	2.0 A	4.0 A
Max. capacity	4 x 100 ml			
Allowed density	1.2 kg/dm <sup>3</sup>			
Speed (RPM)	15000			
Force (RCF)	21382			
Kinetic energy	8600 Nm			
Obligatory inspection (BGR 261)	no			
Ambient conditions (EN 61010-1)	<p>Indoors only</p> <p>Up to 2000 m above sea level</p> <p>2°C to 35°C</p> <p>Maximum relative humidity 80% for temperatures up to 31°C, linearly decreasing to 50% relative humidity at 40°C.</p>			
– Set-up site				
– Altitude				
– Ambient temperature				
– Humidity				
– Excess-voltage category (IEC 60364-4-443)	II			
– Pollution degree	2			
Device protection class	I			
Not suitable for use in explosion-endangered areas.				
EMC				
– Emitted interference (suppression of radio interference)	EN 55011, Group 1, Class B EN 61000-3-2 EN 61000-3-3	FCC Class B	EN 55011, Group 1, Class B EN 61000-3-2 EN 61000-3-3	FCC Class B
– Interference immunity	EN 61000-6-2	----	EN 61000-6-2	----
Noise level (dependent on rotor)	$\leq 68$ dB(A)			
Dimensions				
– Width	395 mm			
– Depth	520 mm			
– Height	346 mm			
Weight	approx. 35 kg			

Manufacturer	Andreas Hettich GmbH & Co. KG D-78532 Tuttlingen		
Model	UNIVERSAL 320 R		
Type	1406-20		1406-21
Mains voltage ( $\pm 10\%$ )	200-240 V 1~	240 V 1~	115-127 V 1~
Mains frequency	50 Hz	60 Hz	60 Hz
Connected load	800 VA		950VA
Current consumption	4.0 A		8.0 A
Cooling medium	R 404A		
Max. capacity	4 x 100 ml		
Allowed density	1.2 kg/dm <sup>3</sup>		
Speed (RPM)	15000		
Force (RCF)	21382		
Kinetic energy	8600 Nm		
Obligatory inspection (BGR 261)	no		
Ambient conditions (EN 61010-1)	<ul style="list-style-type: none"> <li>- Set-up site</li> <li>- Altitude</li> <li>- Ambient temperature</li> <li>- Humidity</li> <li>- Excess-voltage category (IEC 60364-4-443)</li> <li>- Pollution degree</li> </ul>		
	<p style="text-align: center;">Indoors only Up to 2000 m above sea level 5°C to 35°C Maximum relative humidity 80% for temperatures up to 31°C, linearly decreasing to 50% relative humidity at 40°C.</p> <p style="text-align: center;">II 2</p>		
Device protection class	I		
Not suitable for use in explosion-endangered areas.			
EMC			FCC Class B
- Emitted interference (suppression of radio interference)	EN 55011, Group 1, Class B EN 61000-3-2 EN 61000-3-3		
- Interference immunity	EN 61000-6-2		----
Noise level (dependent on rotor)	$\leq 58$ dB(A)		
Dimensions			
- Width	401 mm		
- Depth	695 mm		
- Height	346 mm		
Weight	approx. 52 kg		