



# Service Manual

KC 4   
Amelung

## 1. Table of contents

1.	Table of contents.....	2
2.	Appliance properties and technical data.....	3
2.1	Appliance description.....	3
2.2	Technical data.....	3
2.3	Legend.....	4
2.4	Illustrations.....	5
2.4.1	Top view.....	5
2.4.2	Rear view.....	6
2.4.3	Internal view.....	7
3.	Safety recommendations.....	8
3.1	General recommendations.....	8
3.2	Recommendations for repairing the KC4Δ.....	8
4.	Accessories/equipment.....	9
4.1	Tools.....	9
4.2	Measuring devices.....	9
5.	Measuring method.....	10
6.	Appliance installation.....	11
7.	Disassembly.....	12
8.	Circuit description.....	13
9.	Settings and tests.....	16
9.1	Preparation (before switching on the appliance).....	16
9.2	Setting heating current.....	16
9.3	Setting module temperature.....	16
9.4	Testing operating voltages.....	17
9.5	Testing measuring station speed.....	17
9.6	Mechanical setting of the sensor.....	17
9.7	Setting the electrical gain.....	18
9.8	Setting the LCD display contrast.....	18
10.	Spare/replacement parts.....	19
11.	Printer configuration.....	20
12.	KC4Δ circuit diagrams and mounting plans, exploded drawings.....	21

## **2. Appliance properties and technical data**

### **2.1 Appliance description**

The Amelung KC4 $\Delta$  is a semi-automatic mechanical clot recognition system for determining prothrombin times (PT), activated partial thromboplastic times (APTT) and fibrinogen concentrations that are determined using the Clauss method.

The KC4 $\Delta$  can be used for all clotting time tests which end in the formation of fibrin. Both plasma and full blood can be used as samples in conjunction with appropriate reagents.

The samples and reagents are pipetted manually. Measurements up to the clotting time are automatic.

### **2.2 Technical data**

**Type:**

Clot analysis machine; table-top

**Operating principle:**

Ball method

**Measuring channels:**

4 (mechanical)

**Display:**

Liquid crystal display (LCD)

**Incubation stations:**

8

**Reagent stations:**

5

**Dimensions:**

Height: 120 mm

Width: 354 mm

Depth: 450 mm

**Weight:**

6.3 kg

**Electrical specifications:**

Voltage: 100-240 Volt/50-60 Hz

Current consumption: 1.5 A at 110 Volt; 0.4 A at 230 Volt

**Temperature control:**

Measuring module: 37.3 °C  $\pm$  0.5 °C

**Measuring time:**

minimum: 4.5 seconds

maximum: 999.9 seconds

## 2.3 Legend

see also chapter



Item number

(N00000)

## 2.4 Illustrations

### 2.4.1 Top view

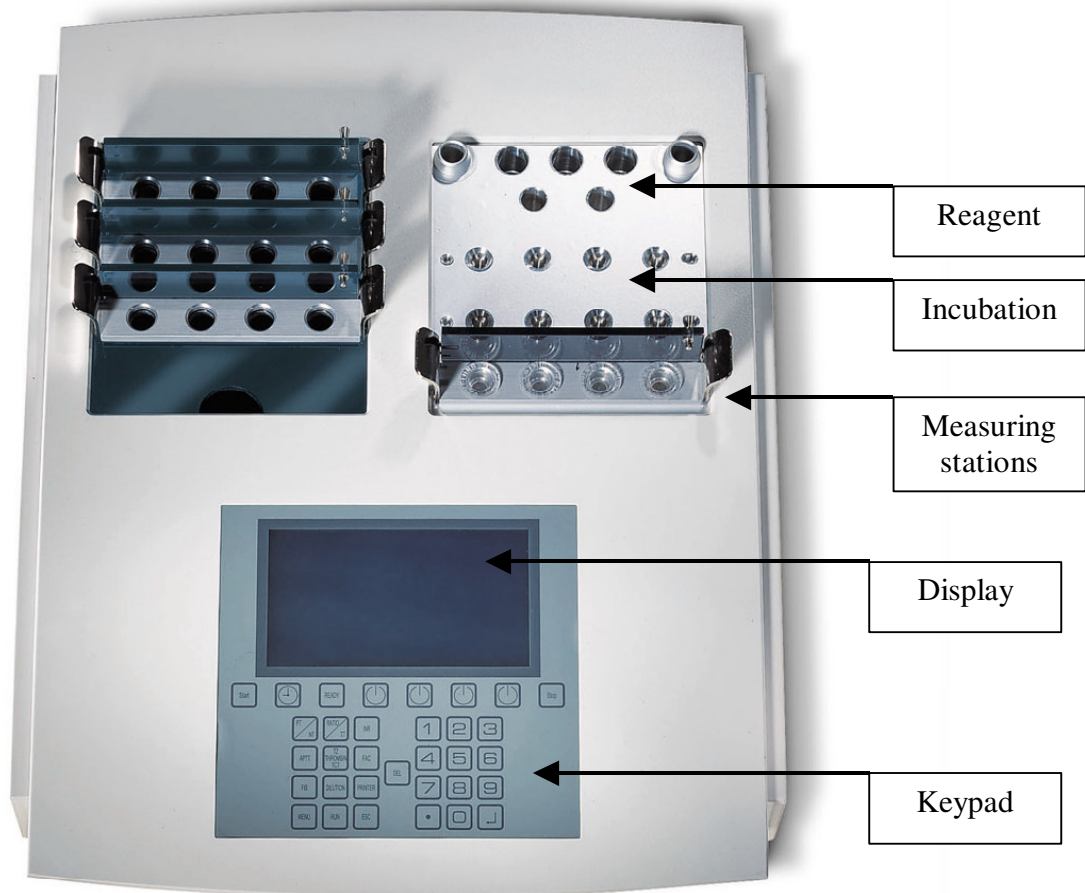

## 2.4.2 Rear view

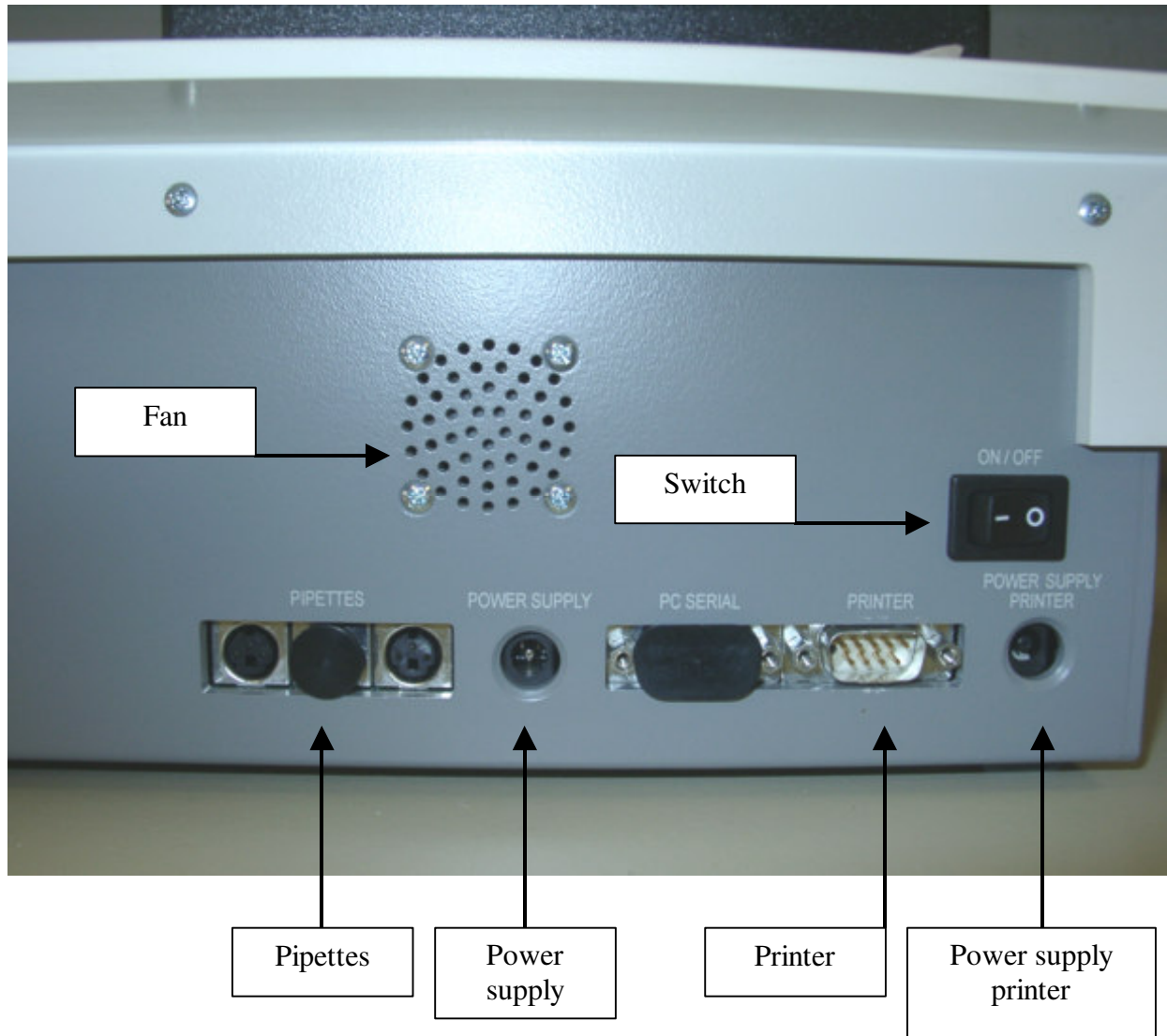

Rear view with connection panels

### 2.4.3 Internal view

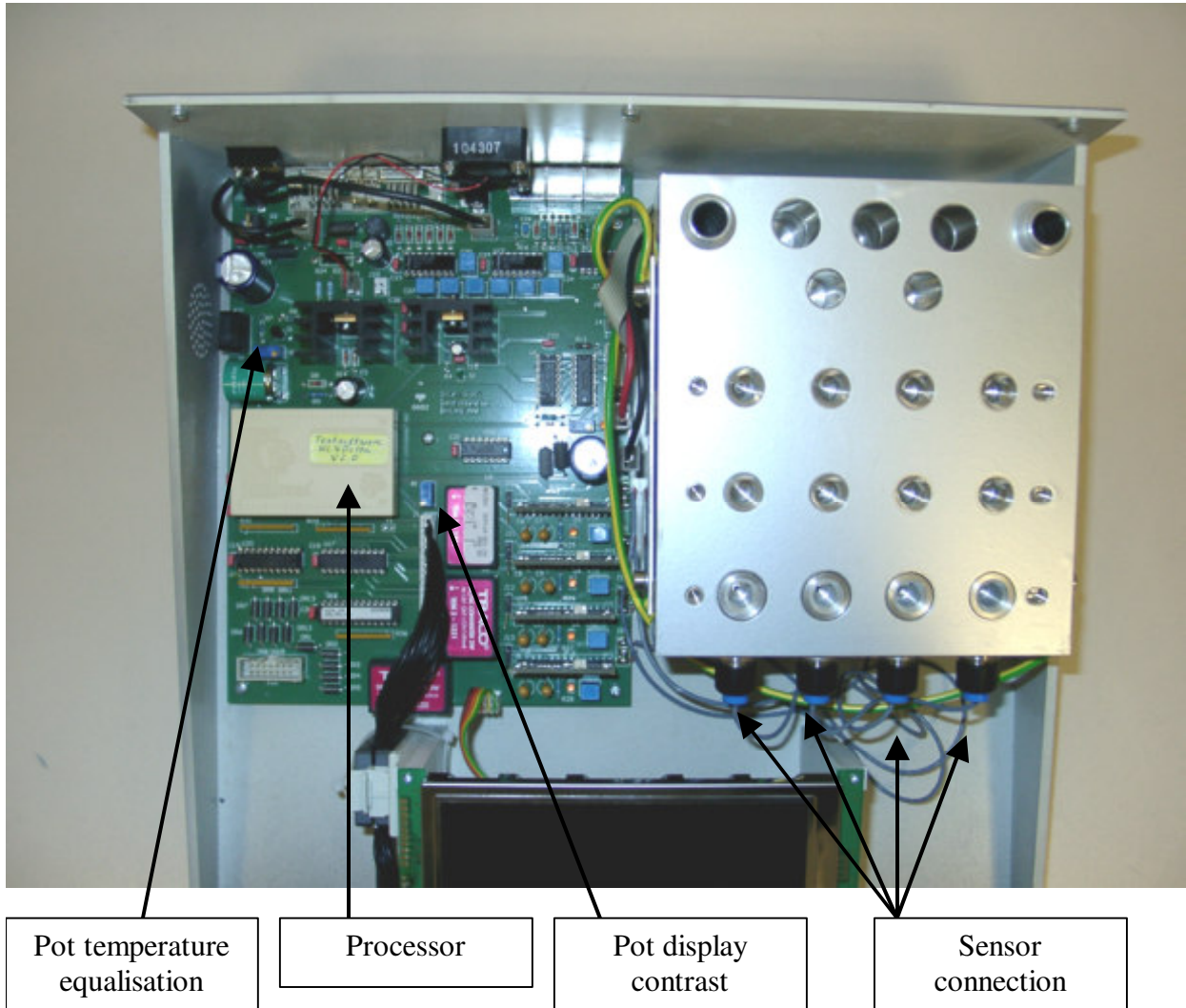

### 3. Safety recommendations

**IMPORTANT!**

Read these instructions carefully and follow them at all times!  
Take note of warnings and recommendations!  
This will avoid damage to equipment and personal injury!



#### 3.1 General recommendations

If the KC4<sup>Δ</sup> displays faults which could endanger patient or operator it should not be used (IEC 61010).

Protective clothing, especially disposable gloves, must be worn. You may come into contact with infected plasma (hazardous substance).

Protective clothing, especially disposable gloves, that have been in contact with hazardous substances (e.g. infected plasma) must be disposed of immediately (Technical Rules for Hazardous Substances - *Technische Regeln für Gefahrstoffe* (TRGS)).

Plasma samples and reagents are special waste. The special waste must be disposed of in accordance with industrial instructions (laboratory regulations).

#### 3.2 Recommendations for repairing the KC4<sup>Δ</sup>

The appliance must not be used for tests whilst under repair. If possible, the appliance must be disconnected from the power supply.

After the KC4<sup>Δ</sup> has been repaired control measurements are to be carried out to check the appliance is working properly. The measured values obtained must correspond to the reference ranges.



## 4. Accessories/equipment

### 4.1 Tools

No special tools are required to service the KC4Δ.

### 4.2 Measuring devices

The following measuring devices required to check the functions of the KC4Δ:

Standard measure	J10013
Magnetic field strength measuring device micro (FM1micro)	J03100 (230 Volt)
or	or
Magnetic field strength measuring device micro (FM1micro)	J03110 (110 Volt)
Thermometer	
Digital multimeter	
Storage oscilloscope	
Current measuring adapter	J01825

## 5. Measuring method

The KC4 $\Delta$  is an electro-mechanical clot recognition system. The system uses a special cuvette that contains a special steel ball. The sample is placed in the cuvette. After the appropriate incubation period the cuvette is placed in the measuring station of the KC4 $\Delta$ . The measuring station rotates slowly, making the cuvette turn along its longitudinal axis. Since the cuvette is positioned at an angle in the measuring station, the ball always remains at the lowest point in the cuvette thanks to gravity and the magnetic field. Directly opposite the position of the ball is a magnetic sensor. When the appropriate reagent is added, a timer is started. When clotting begins, fibrin threads pull the ball from its position as determined by gravity. This change in position triggers an impulse in the magnetic sensor which stops the timer electronically.

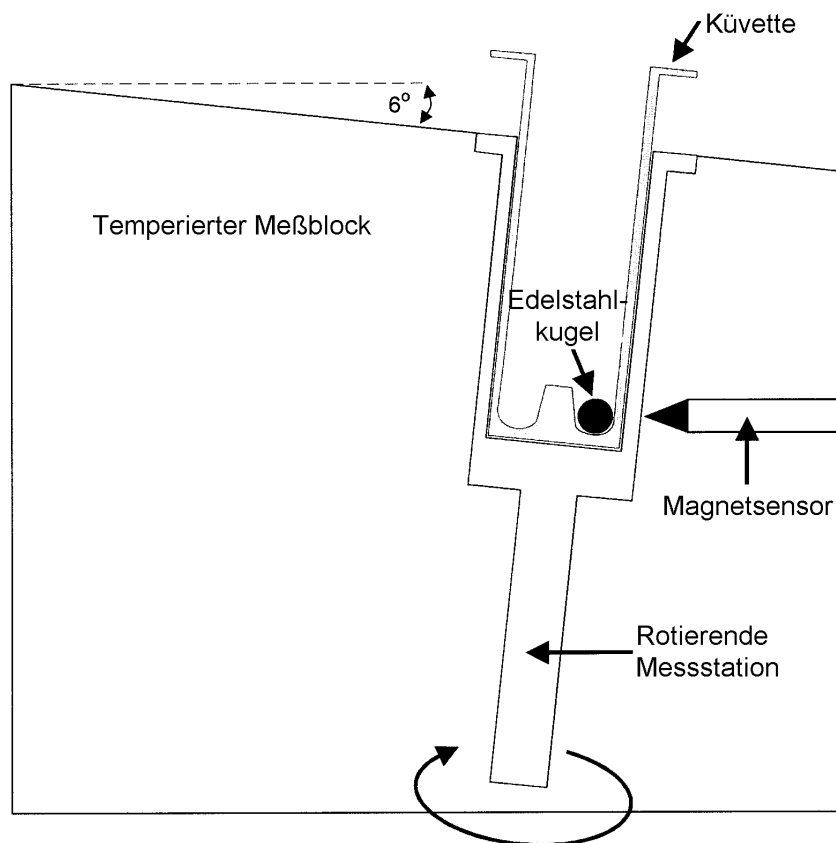

Diagram of the measuring system (available for KC4 $\Delta$  4x)

## 6. Appliance installation

The KC4 $\Delta$  must be placed on a level, stable surface. The environment should be dust-free and at a fairly constant temperature (max. room temperature 30 °C). The appliance should not be used in strong draughts or in direct sunlight. The fan opening on the rear of the casing must not be covered.



2.4.2

**WARNING!**

Failure to observe these instructions could cause the **KC4 $\Delta$**  to malfunction!



Should the KC4 $\Delta$  malfunction, it must be ensured before carrying out any repairs that the environmental requirements described above have been satisfied. The appliance must be kept in a horizontal position at all times.

## 7. Disassembly

To disassemble the KC4 $\Delta$ , remove the 3 screws on the rear and the 2 screws on the underside of the appliance (front). The top cover can now be removed. When doing so make sure that the keypad is firmly attached to the top cover. Before completing removal, the connecting cable must be carefully unplugged from the J18 plug connector on the main board.

The keypad is glued onto the top cover. It can be removed to be replaced. Any remnants of glue which remain must be removed before gluing on a new keypad.  
**Remnants of glue must not be removed with cleaners that contain solvents!**

The display is fastened to the appliance with 4 screws. Below the display is the inverter board (**HIGH VOLTAGE!**) for the display lighting. This board can be taken out after removing the two fixing screws.

**WARNING!**  
**High voltage!**  
Do not touch live components!  
**DANGER!**



The main board is secured in the lower part of the appliance with 5 screws. All connectors and sensor connections must be removed to take the board out.

To remove the measuring module the 4 screws on the underside of the appliance and all measuring module connectors must be removed. The sensor wires are to be disconnected prior to disassembly. The 4 heating transistors are located on the underside of the measuring module. From here you also have access to the drive belt.

## 8. Circuit description

The KC4 $\Delta$  consists of the following relevant components:

- Power pack
- Keypad
- Adapter board
- Display
- Main board
- Processor
- Measuring module
- Heating board

The appliance is powered by an external 12-Volt power pack. This power pack should always be completely replaced during servicing, as the power pack also provides protection as well as powering the appliance.

Internally these 12 Volts generate a 5 Volt voltage, and a 6.5 Volt voltage for the printer. The 6.5 Volt voltage for the printer cuts in if the measuring module temperature exceeds 35 °C.

In addition, voltages of –12 Volt and –5 Volt are generated. These voltages should always be checked during servicing.



9.4

To light the display an additional **high voltage** is generated in the inverter, which is fitted beneath the display. **Under no circumstances should this high voltage be measured with a normal multimeter.**

**WARNING!**  
Do not touch live components!  
**DANGER!**



The processor is entirely responsible for controlling the appliance's processes. All other appliance components are linked to the processor directly or via driver stages.

Because of the 8-bit broad processor data bus the data from keypad, pipettes and measuring channels are made available via a multiplexer on pins 2-7, 30 and 32 of the processor.

The display is connected directly to the processor. The display contrast can be adjusted using pot R1.



9.8

The stepping motor for driving the measuring stations is controlled by IC U6 and IC U5. A rectangular signal with c. 1 kHz generated by the processor is applied to pin 14 of IC U6. This signal is converted and applied to the IC U5 output stages. The frequency and speed of the motor are set.

The temperature of the measuring module is scanned using the NTC TR1 resistor. This resistor forms a voltage divider with the R5 resistor, whose voltage is scanned at pin 39 of the processor and converted to an 8-bit data value internally. Pot R3 is used to set the reference voltage of the AD transformer in the processor.



9.3

The heating of the measuring station module is controlled by a PWM signal from pin 12 in the processor. The lower the temperature, the broader this signal. The PWM signal is integrated with IC U1, so that the 4 heating transistors are driven with direct voltage.

To prevent the measuring module overheating in the event of a fault there is a thermostatic switch which interrupts the power supply to the heating transistors if the temperature exceeds 60 °C. The heating is switched back on once the module has cooled down.

The BZ1 acoustic sensor is controlled via pin 13 of the processor and transistor Q1.

The four hybrid modules U13-U16 are used to assess the measuring pulses recorded by the sensors J24-J27. If the movement of the special steel ball is detected by the beginning of clotting, one of the LEDs D3-D6 lights up by way of a check. The hybrid modules are supplied with the required -12 Volt und +12 Volt via the DC/DC transformers U8 and U9.

The A1 rechargeable battery supplies the processor with backup voltage when switched off. When the battery is fully charged the appliance data is retained for c. 2 weeks.

**IMPORTANT!**

- The board must **not** be equipped at the point of the R10 resistor.  
The battery would be drained too quickly via this resistor.
- For appliances up to no 02N60100 it should always be checked during servicing whether the board is equipped at this point.  
If the board is equipped, the resistor should be removed.
- Position of resistor: below the processor!

**If the battery is drained too quickly or the processor removed from the appliance, date, time and test parameters will be lost!**



**Master password 9367:**

This password remains valid at all times and cannot be changed or blocked. The master password can also be used to create a new user password if the existing one is forgotten.

Because the master password is also used to open the service menu, under no circumstances should it be given to customers or users.

## 9. Settings and tests

### 9.1 Preparation (before switching on the appliance)

Turn pot R2 to right limit (maximum heating current)  
Turn pot R3 to left limit  
Switch on appliance  
Pre-set the display contrast with pot R1

### 9.2 Setting heating current

Note: appliance temperature and room temperature c. 20 °C

Preparation:

An ammeter is to be connected to the 12 V supply lead of the KC1Δ.  
(measuring adapter J01825).

Press “START” and “STOP” keys simultaneously  
The master password window opens.  
Enter password (“9367”) and confirm with “ENTER”

The maximum heating current is set with the “STOP” key. Press the “STOP” key 33 times until the bar is at the 10th line (from software version V2.2 this is pre-set).  
If a mistake is made, the heating current value set can be corrected using the “START” and “STOP” keys.  
The setting is saved by pressing “ENTER”.

The total current consumption during the heat-up phase should be c. 4.8 A.  
At the end of the heat-up phase the total current consumption should fall to c. 1.2 A.

### 9.3 Setting module temperature

To do this, a cuvette approx. one-third filled with water is to be placed in the hole at the bottom right above the 4th measuring station (bottom incubation row).  
The water temperature in the cuvette is measured with a thermometer.  
The temperature should be 37.4 °C (±0.5 °C).

If the temperature display rises above 35 °C after the KC4Δ is switched on, the display switches from showing the thermometer to the main menu.  
The menu is changed with the “ENTER” key.  
The clot measurement is displayed.

The temperature calculated by the processor is shown in the top right of the display.  
This temperature display must now be compensated using pot R2 with the temperature reduced by 0.3 °C by the thermometer.



Example:    KC4Δ display:            37.1 °C  
                  Thermometer:            33.8 °C

The display would now have to be set to 33.5 °C with pot R2.

The KC4Δ now sets the module temperature to the new value. Once the new module temperature has been reached and the water in the cuvette has reached this temperature, the temperature should be checked again. The thermometer should now show 37.4 °C. If not, the display temperature must be compensated again with pot R2 using the above procedure.

#### 9.4 Testing operating voltages

at pin 11 KC-Sens U13 + U 16	c. +12 V DC
at pin 8 KC-Sens U13 + U16	c. -12 V DC
at U2 pin 3	c. + 5 V DC
at printer power supply jack	c. + 6.2 V DC

(voltage only applied if the module temperature is > 35 °C)

#### 9.5 Testing measuring station speed

Measure the speed (50 rpm) with a stopwatch. To do this, place a cuvette marked on the edge in the measuring station and count the revolutions with the appliance running.

#### 9.6 Mechanical setting of the sensor

In addition to a hall sensor, the sensor (X10009) also contains a permanent magnet, whose magnetic field acts on the steel ball in the cuvette with a defined force. The force is set by the distance of the sensor to the measuring station. This setting is made by Trinity Biotech GmbH and must not normally be corrected.

The sensor setting can be checked with the field strength measuring device FM1 micro J03100 (230 V) or J03110 (110 V) from Trinity Biotech GmbH.

To check the magnetic field strength the measuring module of the KC4Δ and the magnetic field detector of the FM1 micro must have an operating temperature of c. 37 °C.

The FM1 micro must be zero offset immediately prior to the test. This is done by pressing the zero key on the FM1 micro. It is important when doing this that the magnetic field detector is not near any magnetic field. It must not therefore be in the measuring station whilst performing the zero offset.

The magnetic field detector is now inserted into the measuring station to be tested and secured with the centring ring. The maximum value of the display can now be found by carefully turning the detector. This maximum value should be 82 ±2 scale divisions.

If the value is not correct or if the sensor has to be replaced, the sensor lock nut has to be removed. The magnetic field can be set to 82 scale divisions by rotating the sensor forwards and backwards.

Then secure the sensor with the lock nut.

The sensor setting should be re-checked after every zero offset.

**The electrical gain must be reset after any mechanical sensor adjustment.**

## 9.7 Setting the electrical gain

First the standard measure from Trinity Biotech GmbH (J10003) is inserted into the measuring station to the bottom of the measuring beaker and secured with the centring ring.

The voltages measured by J10 - J13 at MP3 are set to 3 V<sub>ss</sub> by means of a storage oscilloscope and a 1:1 probe with the pot situated on the KC-Sens hybrid.

It is important here that the measurement is made with the "DC" setting, so as not to falsify the result.

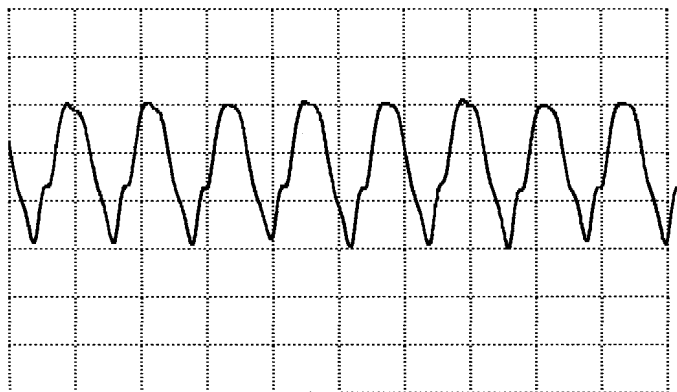

DATE: 04.03.2003  
TIME: 15:18

SIGNALPARAMETER:

CH2 - VOLTS/DIV:=1V  
CH1 - VOLTS/DIV:=>1V  
TIMEBASE-SEC/DIV:=1s  
TRIGGERLEVEL CH1:AUTO  
PRETRIGGER :0%  
DELTA CURSOR :OFF  
ADD CH1,CH2 :ON

PRINTERPARAMETER:

ZOOMRANGE - CH1:0-9  
HARDCOPY SOURCE :HM 408

REMARKS:



Measuring signal with standard measure

## 9.8 Setting the LCD display contrast

The contrast of the LCD display can be adjusted using pot R1.

**Important!**

**The contrast of the LCD display is temperature-dependent.**

**The setting should therefore only be made once operating temperature has been reached.**

## 10. Spare parts

<b>Part No</b>	<b>Description</b>
N20520	Mechanical UnitKC4 Delta Micro (AN)
211010	Resistor NTC temperature control probe
X10091	Measuring cup Micro KC4A/KC10A complete
X10009	Sensor KC (AN)
111049	Belt pulley KC4A/KC10A motor
241101	Motor RDM 42/12 G A2
121562	Thermal cut-off switch P82 60 5
120506	Flat belt 81,6x1,2x6mm
234167	Cable gy 1,3x320 Rö M4/Fsh 6,3
234169	Cable gy 1,3x130 Rö M4/Fsh 6,3
341322	Grooved pin 3x22 DIN 1474 S4
121505	Thermal cut-off bracket
N51000	PC-board KC4 Delta MB Mikro AN
218725	IC 7805 voltage regulator TO-220
240042	Buzzer Piezo KC1 Delta
249100	Accumulators-Nc3-60 Dm 3,6V-60Mah
X10083	Sensor plug AN 320mm cable
221004	Socket 3pol Mini-DIN mounted
222009	Plug 9pinned SUB-D 90°
221005	Voltage supply socket Kycon
N51100	PC-board KC4 Delta ADP
247207	Display LMG7420PLFC-X
247217	Inverter INVC 191
241011	Ventilator SEPA MFB30A12
144020	Casing (upper section) KC4 Delta
144021	Casing (lower section) KC4 Delta
244068	Mercury Switch
113472	Cover EMV MiniDIN-socket
122059	Cover EMV 9pol Sub-D
122507	Collecting pan KC4Delta
273101	Cable 20pol 180mm 2xBu JST B20BXH
273029	Cable 14pol 200mm
273257	Cable 10pol 200mm 2xSteck. 10pol
273064	Cable 5pol 160mm Display/Inverter
234165	Cable black 0,93x250 2xFsh6,3iso
234166	Cable rd 0,93x200 2xFsh6,3iso
341210	Grooved pin 1,5x6 S24
245535	Power supply 12V 70W KC Delta
244831	Foil keyboard KC4 Delta

## 11. Printer configuration

If it becomes necessary to reconfigure the DPU 414 printer, the service menu can be accessed by pressing the “Online” key while switching on.

The printer now gives the current settings. The individual items in the list can be changed by pressing the “Online” key. Pressing “Online” switches each option to “On”. Pressing “Paper Feed” switches to “Off”.

After every 8 entries the settings can be saved by pressing “Paper feed”, “Online” jumps to the next 8 entries.

Below are the basic printer settings:

SW1:

(OFF) : Input = Serial  
 (ON) : Printing Speed = High  
 (ON) : Auto Loading = ON  
 (OFF) : Auto LF = OFF  
 (ON) : Setting Command = Enable  
 (OFF) : Printing  
 (ON) : Density  
 (ON) : = 100%

SW2:

(ON) : Printing Columns = 40  
 (ON) : User Font Back – up = ON  
 (ON) : Character Select = Normal  
 (ON) : Zero = Normal  
 (ON) : International  
 (ON) : Character  
 (ON) : Set  
 (OFF) : = U.S.A.

SW3:

(ON) : Data Length = 8 Bit  
 (ON) : Parity Setting = NO  
 (ON) : Parity Condition = ODD  
 (ON) : Busy Control = H/W Busy  
 (OFF) : Baud  
 (ON) : Rate  
 (ON) : Select  
 (ON) : = 9600 Bps

## 12. KC4 $\Delta$ circuit diagrams and mounting plans, exploded drawings

- Block diagram KC4delta (N04000)..... 05.02.03
- Circuit diagram KC4delta MB (N51000)..... 14.09.01  
(Main board, 5 pages)
- Mounting plan KC4delta MB (252129) ..... 03.05.01
- Circuit diagram KC4delta HZ (N51201)..... 01.10.01  
(PC-board heating)
- Mounting plan KC4delta HZ (252137) ..... 26.09.01
- Circuit diagram KC4delta ADP (N51100)..... 14.09.01  
(PC-board adapter keyboard)
- Mounting plan KC4delta ADP (252131) ..... 03.05.01
- Exploded drawing KC4 $\Delta$
- Exploded drawing measuring block KC4 $\Delta$

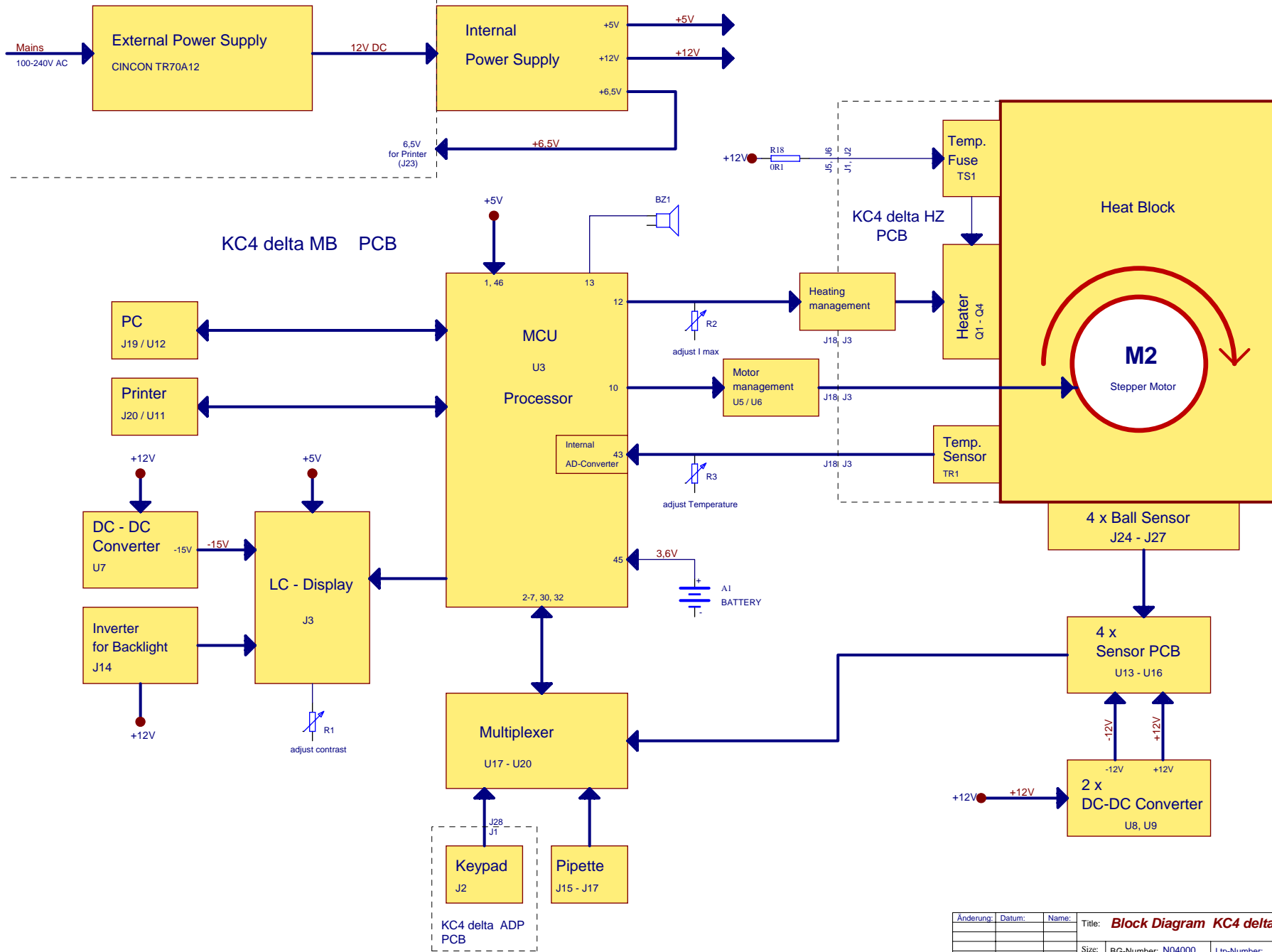

Änderung	Datum	Name	Title: <b>Block Diagram KC4 delta</b>		Trinity Biotech Lehrbrinksweg 59 D-32657 Lemgo Tel.: 05261/963-0 Fax: 05261/963-112
			Size: A3	BG-Number: N04000	
			Revision: 05.02.03	Ltp-Number:	
				Revision:	
			File: Block Diagram KC4d.sch	Print-Date: 10-Jul-2003 Time: 13:02:27 Sheet 1 of 1	

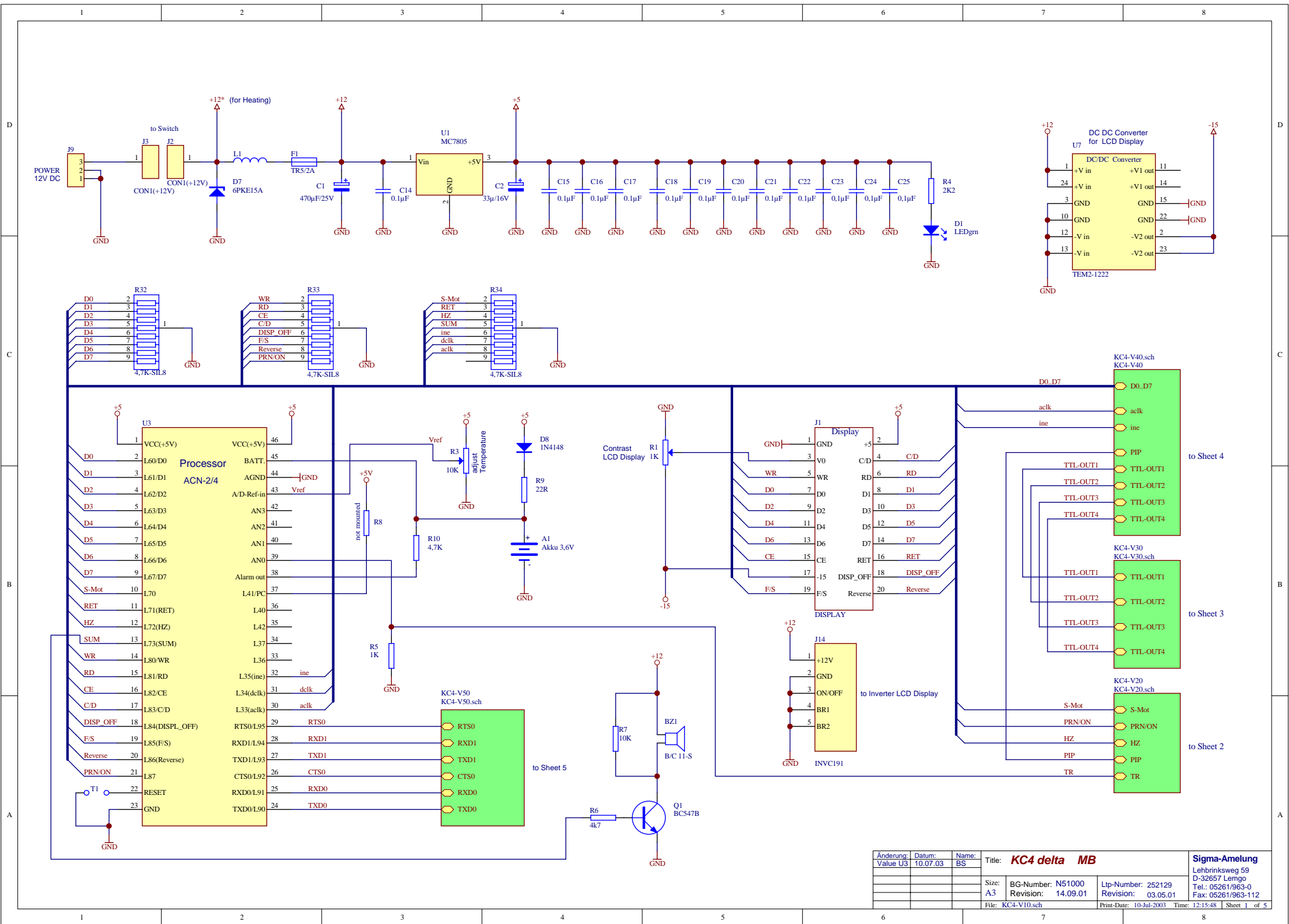

Änderung	Datum:	Name:	Title:	Sigma-Amelung
Value U3	10.07.03	BS	KC4 delta MB	Lehrbrinksweg 59 D-32657 Lemgo Tel.: 05261/963-0 Fax: 05261/963-112
Size:			BG-Number: N51000	Ltp-Number: 252129
A3			Revision: 14.09.01	Revision: 03.05.01
File:	KC4-V10.sch	Print-Date:	10-Jul-2003	Time: 12:15:48   Sheet 1 of 5

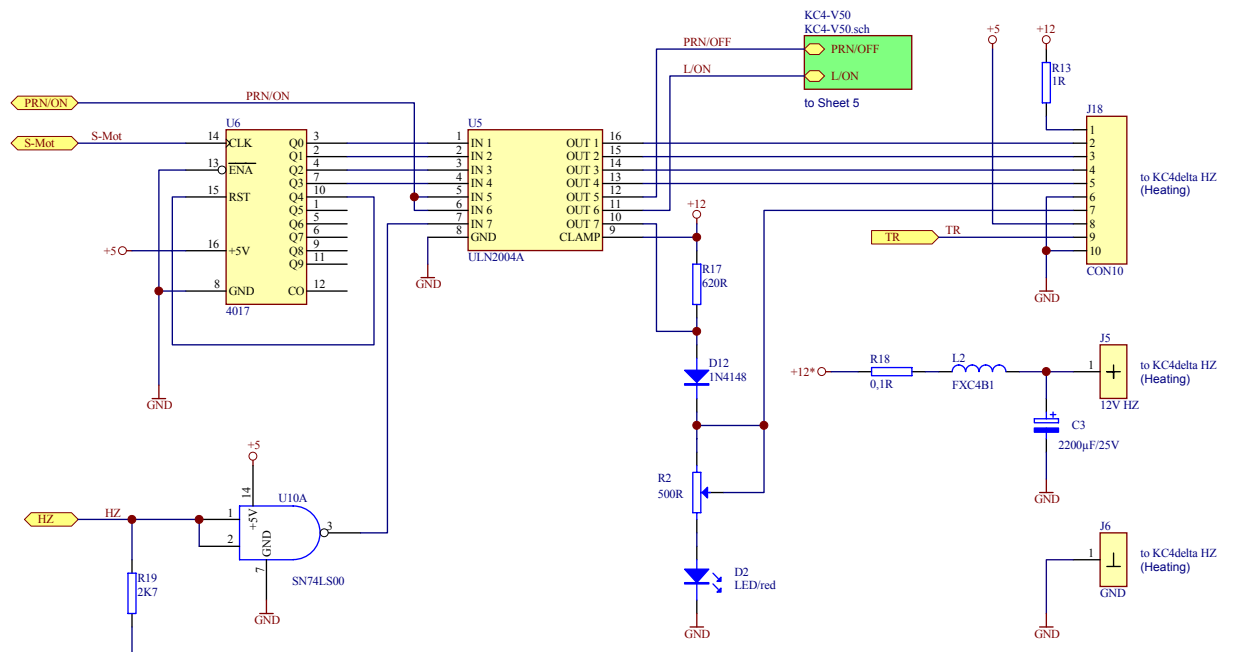
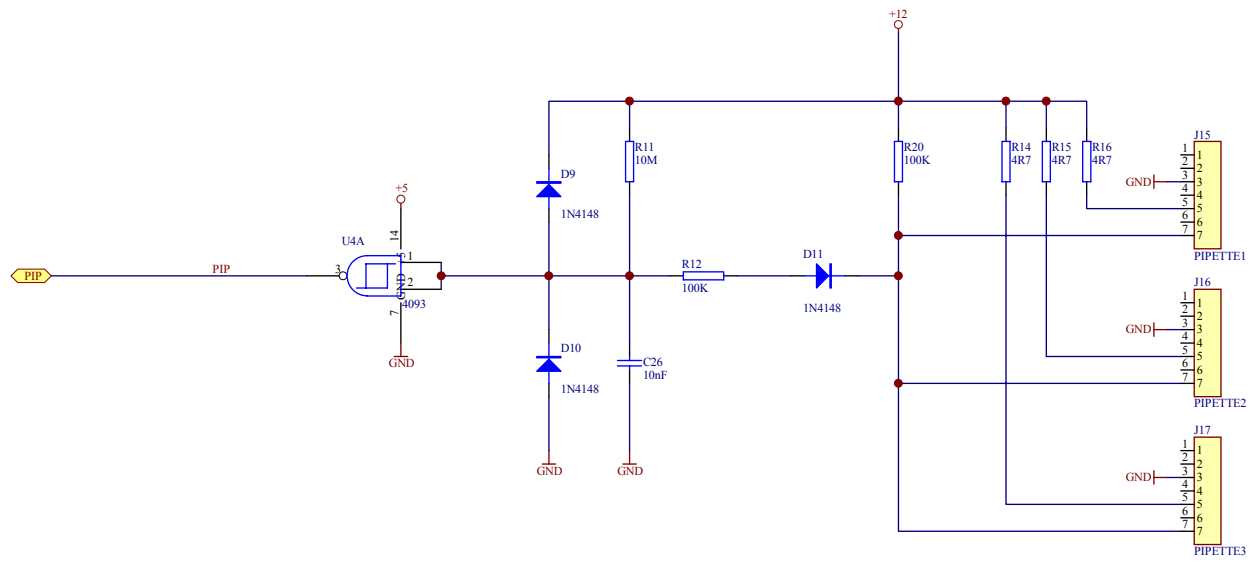

Title: <b>KC4 delta MB</b>			Trinity Biotech	
Size: A3	BG-Number: N51000	Ltp-Number: 252129	Lehrbrinksweg 59	
	Revision: 14.09.01	Revision: 03.05.01	D-32657 Lemgo	
			Tel.: 05261/963-0	
			Fax: 05261/963-112	
File: KC4-V20.sch		Print-Date: 25-Jun-2003 Time: 13:04:30   Sheet 2 of 5		



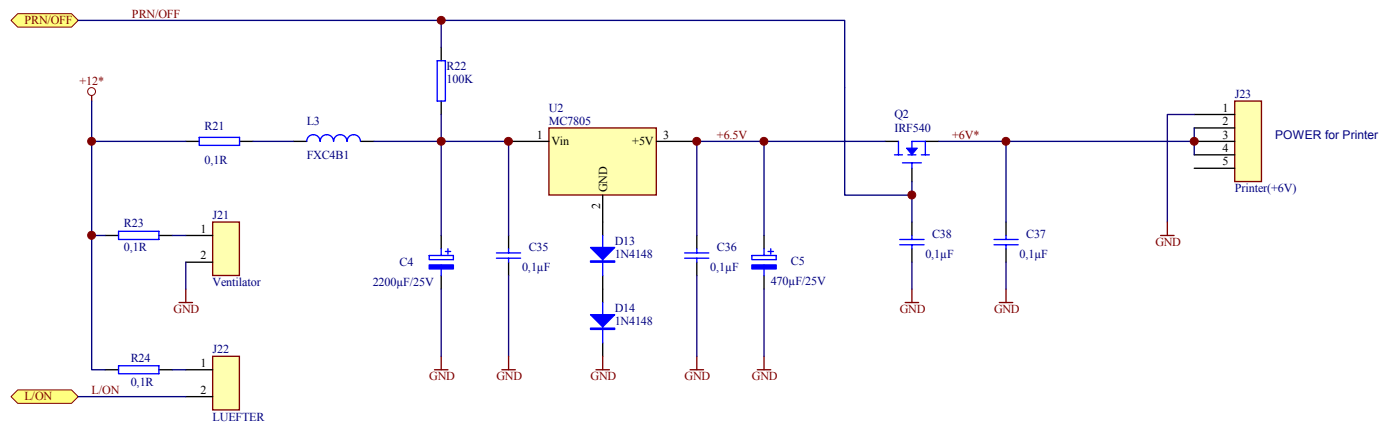
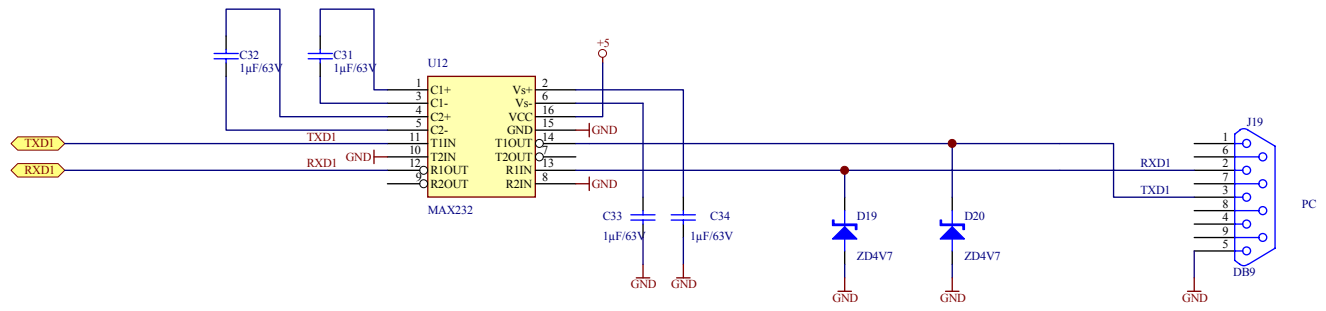
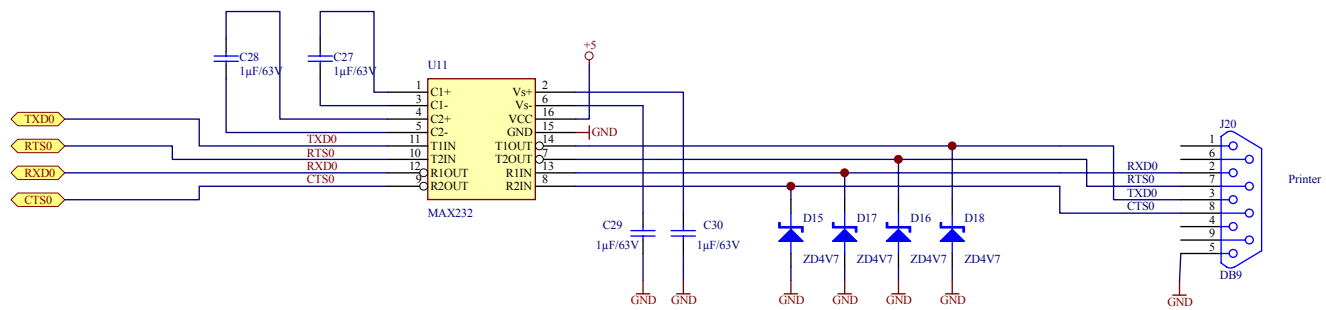

Title: <b>KC4 delta MB</b>			Trinity Biotech		
			Lehrbrinksweg 59		
Size: A3	BG-Number: N51000	Ltp-Number: 252129	D-32657 Lemgo		
	Revision: 14.09.01	Revision: 03.05.01	Tel.: 05261/963-0		
			Fax: 05261/963-112		
File: KC4-V50.sch		Print-Date: 25-Jun-2003	Time: 13:04:31	Sheet 5 of 5	

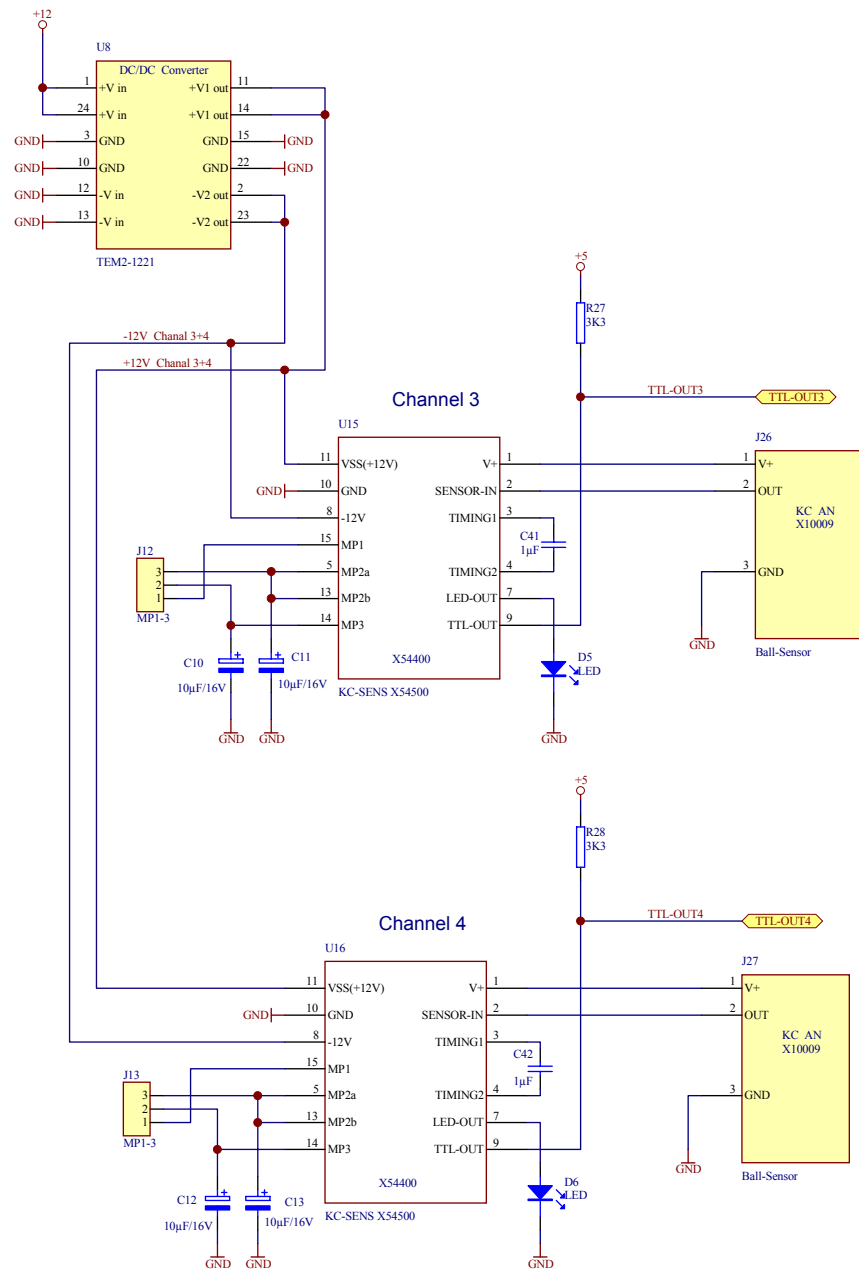
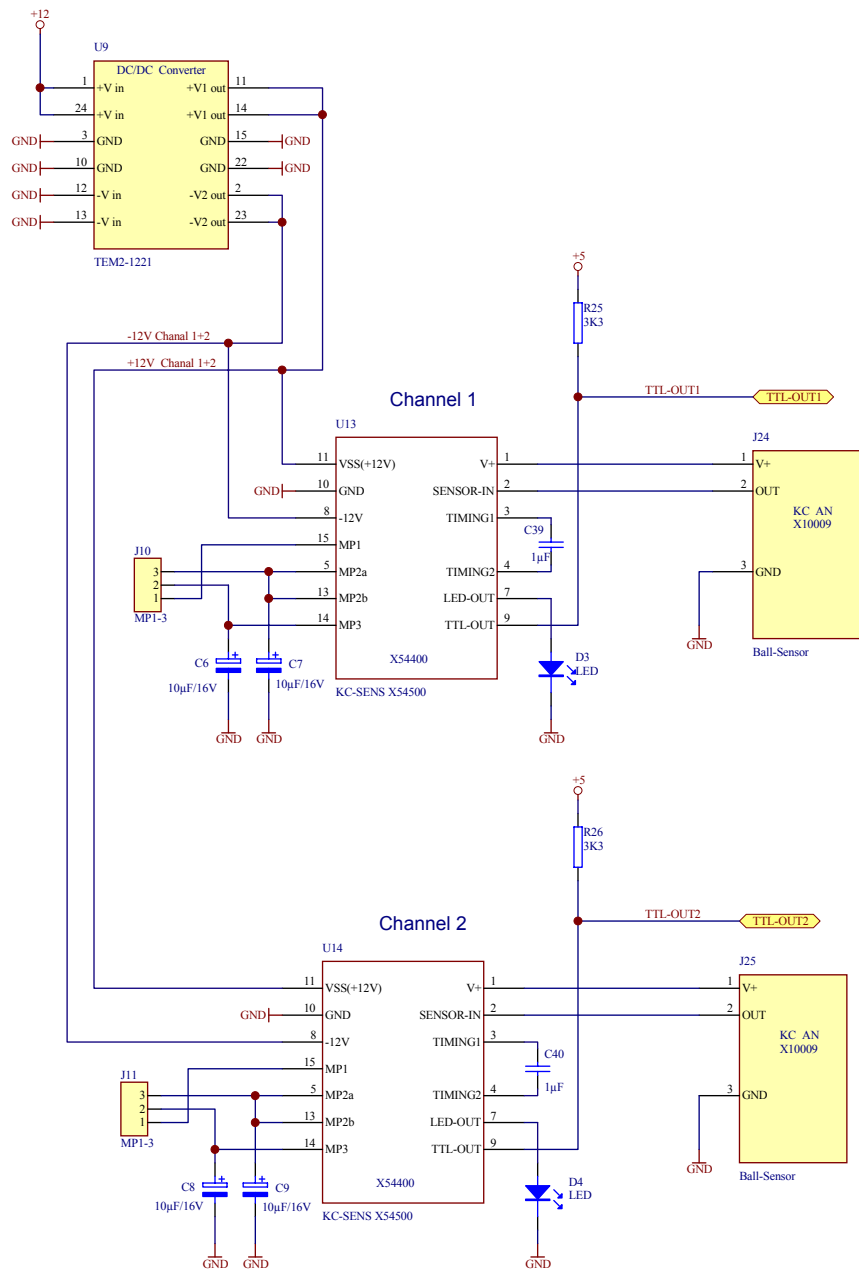

Title: <b>KC4 delta MB</b>			Trinity Biotech	
Size: A3	BG-Number: N51000	Ltp-Number: 252129	Lehrbrinkweg 59	
	Revision: 14.09.01	Revision: 03.05.01	D-32657 Lemgo	
			Tel.: 05261/963-0	
			Fax: 05261/963-112	
File: KC4-V30.sch	Print-Date: 25-Jun-2003	Time: 13:04:31	Sheet 3 of 5	

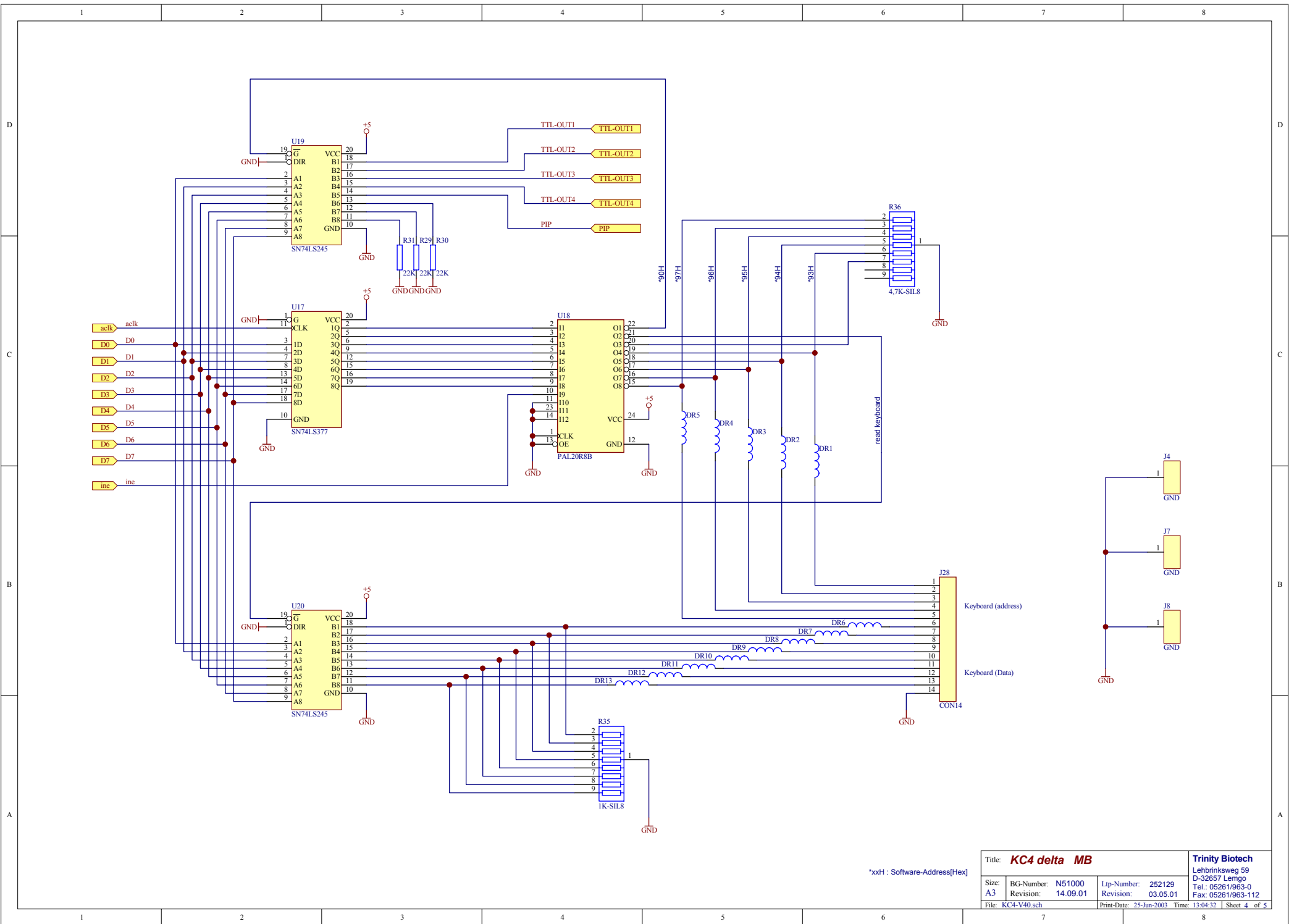

\*xxH : Software-Address[Hex]

Title: <b>KC4 delta MB</b>			Trinity Biotech	
Size: A3	BG-Number: N51000	Ltp-Number: 252129	Lehrbrinksweg 59	
Revision: 14.09.01		Revision: 03.05.01	D-32657 Lemgo	
			Tel.: 05261/963-0	
			Fax: 05261/963-112	
File: KC4-V40.sch	Print-Date: 25-Jun-2003	Time: 13:04:32	Sheet 4 of 5	

MP = Measuring Point

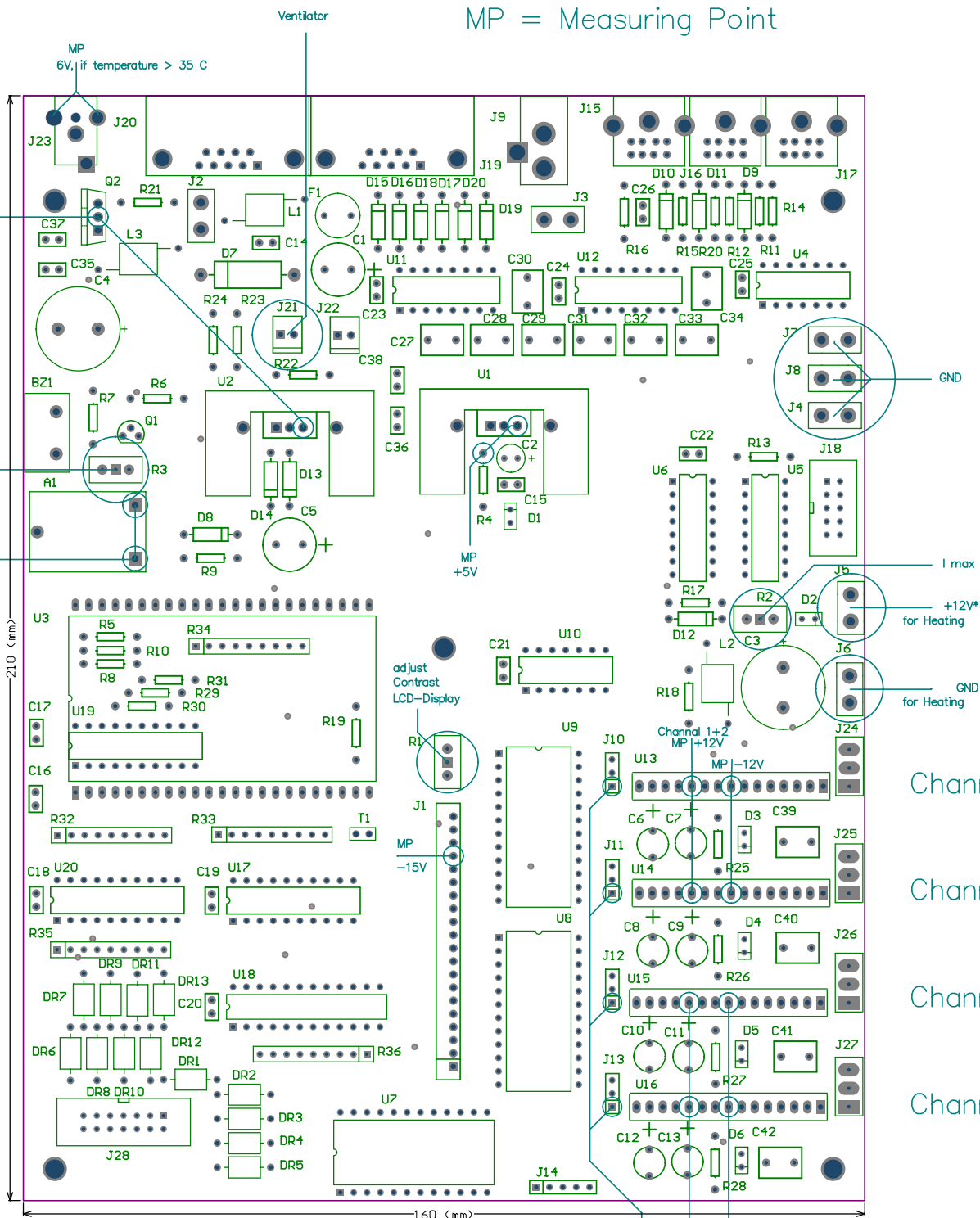

ENGINEER: A. Becker		TITLE: KC4 Delta MB		Trinity Biotech	
PHONE: 05261/963-0				Lehrbrinksweg 59	
DATE: 03.05.2001		PART NO.: 252129		32647 Lemgo	
REV: 01		DATE: 25-Jun-2003			
FILE NAME: KC-4main3GND.PCB		LAYER: Bestueckungsplan		GERBER: .GTO	

Channel 1  
Channel 2  
Channel 3  
Channel 4

MP -12V  
Channel 3+4  
MP +12V  
Channel 3+4  
MP +3.0 Vpp  
electrical adjustment  
Channel 1..4

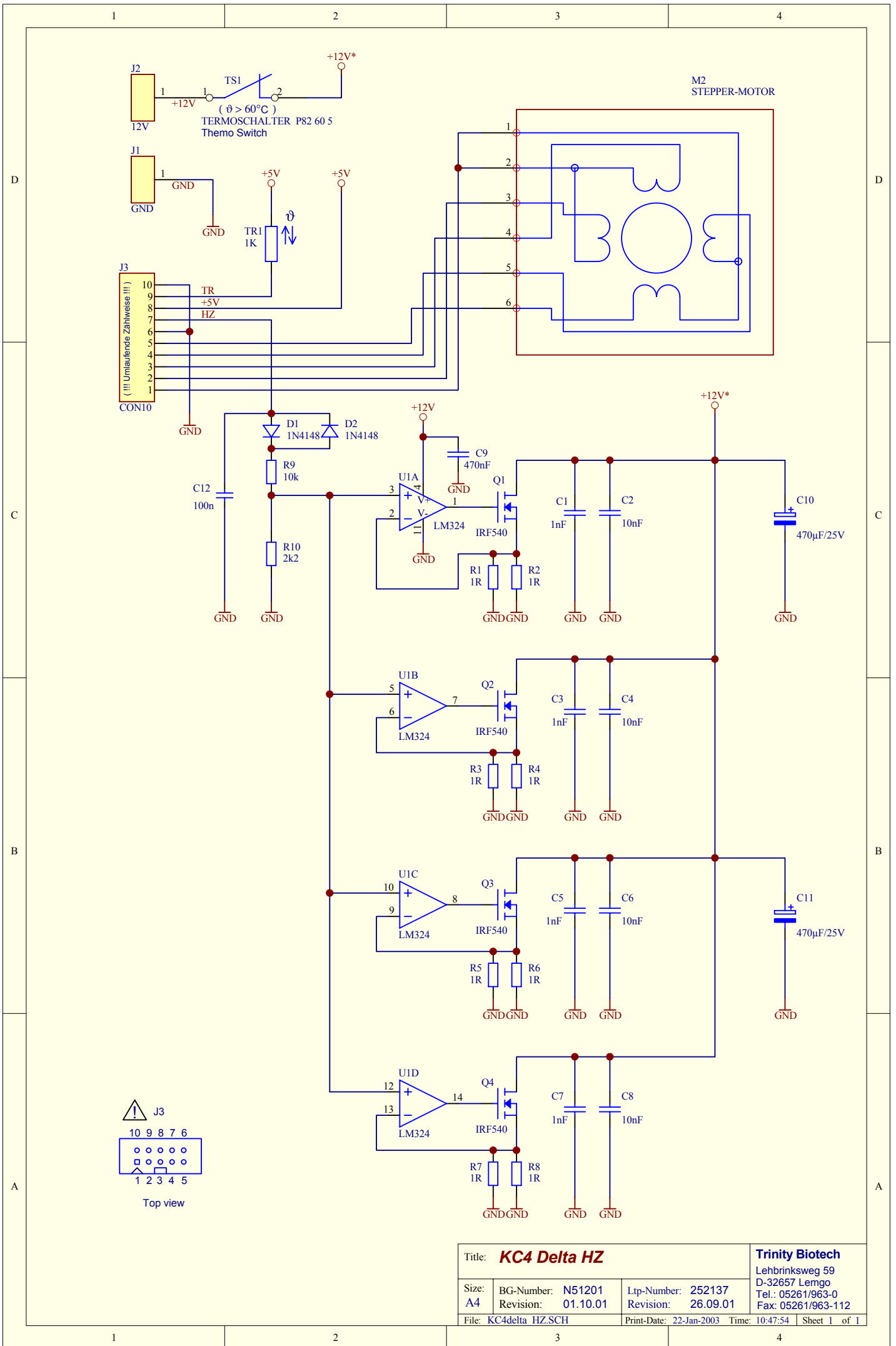

Title: **KC4 Delta HZ**

**Trinity Biotech**

Lehbrinksweg 59  
D-32657 Lemgo  
Tel.: 05261/963-0  
Fax: 05261/963-112

Size: A4

BG-Number: N51201  
Revision: 01.10.01

Ltp-Number: 252137  
Revision: 26.09.01

File: KC4delta HZ.SCH

Print-Date: 22-Jan-2003 Time: 10:47:54 Sheet 1 of 1

6.0

5.0

4.0

3.0

2.0

1.0

0

X

Y

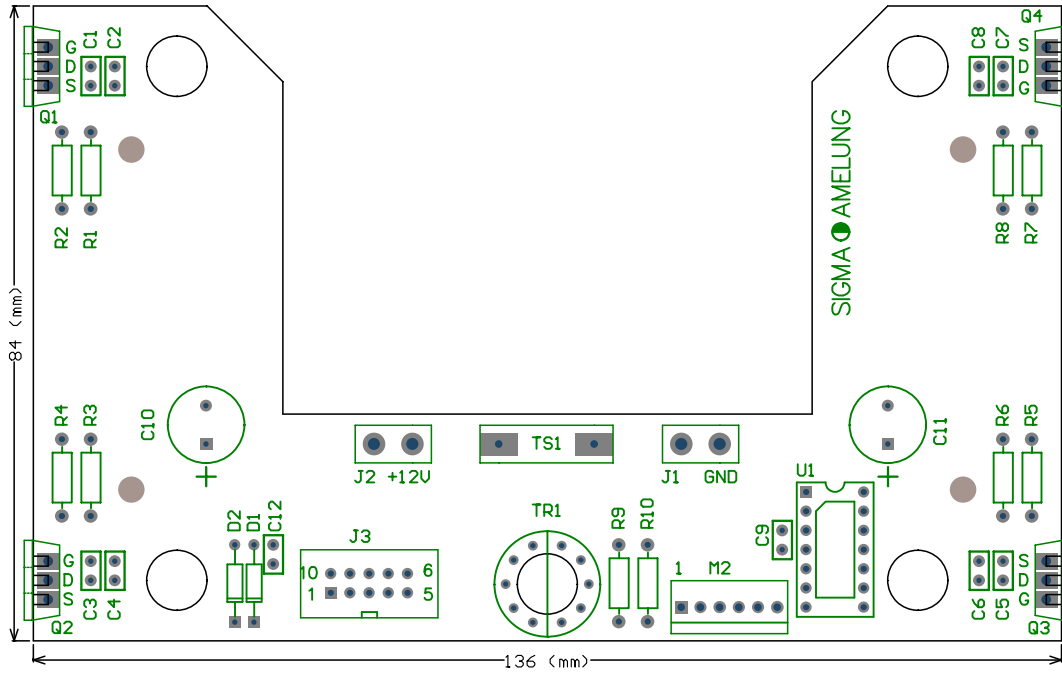

ENGINEER: B. Steiger PHONE: 05261/963-0		TITLE: KC4 delta HZ		Trinity Biotech Lehbrinksweg 59 D-32657 Lemgo	
DATE 26.09.01	PART NO.: 252137	REV: 01	DATE: 16-Jan-2003		
FILE NAME: KC4d-Hz.PCB	LAYER: Bestueckung Top	GERBER: .GTO			

2.0

3.0

4.0

5.0

6.0

7.0

0

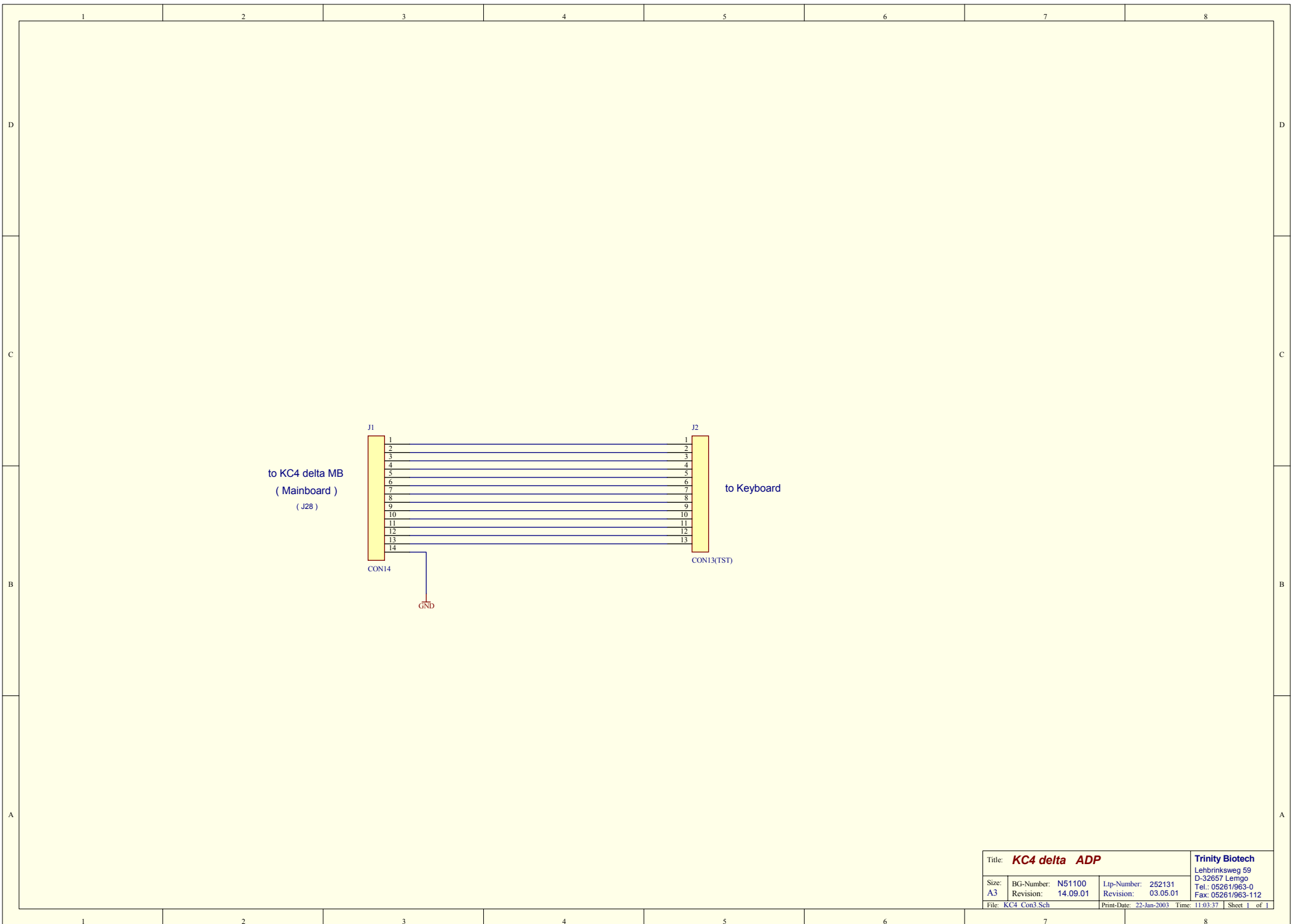

Title: <b>KC4 delta ADP</b>			<b>Trinity Biotech</b>	
Size: A3	BG-Number: N51100	Ltp-Number: 252131	Lehrbrinksweg 59	
Revision: 14.09.01		Revision: 03.05.01	D-32657 Lemgo	
			Tel.: 05261/963-0	
			Fax: 05261/963-112	
File: KC4_Con3.Sch			Print-Date: 22-Jan-2003 Time: 11:03:37   Sheet 1 of 1	

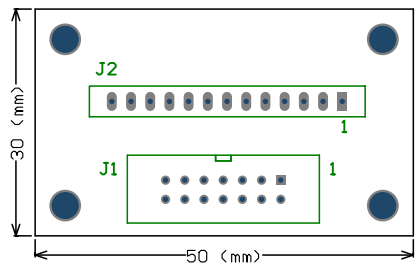
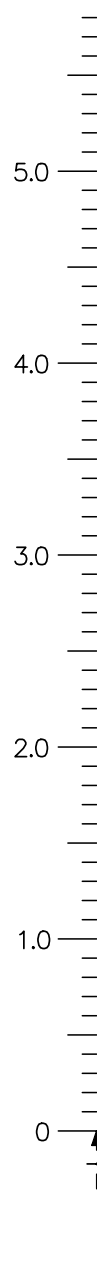
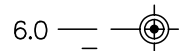

ENGINEER: <b>A. Becker</b>		TITLE: KC4 Delta ADP		Trinity Biotech	
PHONE: 05261/963-0				Lehrbrinksweg 59	
DATE: 03.05.2001		PART NO.: 252131		REV: 01	
				DATE: 15-Jan-2003	
FILE NAME: KC-4con3GND.PCB		LAYER: Mechanical Layer 4		GERBER: .GTO	

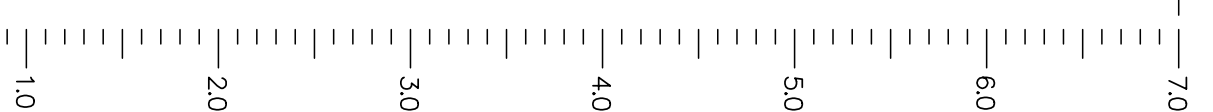
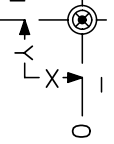



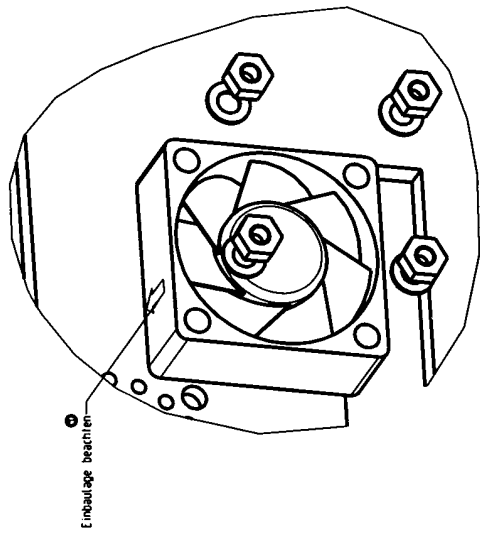

Z  
3.1

Pos	Art. Nr.	Menge	Benennung	Typ
1	144020	1	Gehäuseoberteil KC4 Delta	ASSEMBLY
2	241011	1	Lüfter SEPA MFB 30A12	ASSEMBLY
3	N20520	1	Mechanik KC 4 Delta	ASSEMBLY
4	N51100	1	Platine KC4 Delta ADP	ASSEMBLY
5	N51000	1	Platine KC4 Delta MB Mikro AN	ASSEMBLY
6	C10006	4	Probenthaler PH 4 Delta	ASSEMBLY
7	144021	1	Unterteil KC4 Delta (nach Vorg. Cubitex)	ASSEMBLY
8	122059	2	Abdeckkappe ENV 9pol. Sub-D	PART
9	113472	3	Abdeckkappe ENV Mini-DIN-Buchse	PART
10	113439	1	Abdeckkappe ENV Printersupply	PART
11	122507	1	Auffangschale KC 4 Delta	PART
12	115589	1	Aufnahme Probenthaler	PART
13	247207	1	Display IMG74201FC-x	PART
14	244068	1	Einpoliger Wippschalter bis 10 A 250V	PART
15	355032	4	Facherscheibe A3 2	PART
16	210172	1	Ferrit-Blockkern-geteil	PART
17	xxxxxx	5	Gehäuseschraube-Cubitex	PART
18	247217	1	Inverter INVC 191	PART
19	273101	1	KK20pol. 180mm 2x8u_JST	PART
20	1834040	4	Küvette-Mikromethode	PART
21	335201	2	Schraube KB 18x4,5 W N 1442	PART
22	335205	6	Schraube KB 30x5 W N 1442	PART
23	315308	4	Schraube M3x10 DIN 966 PH	PART
24	335290	10	Schraube WN1443 KB30x7	PART
25	335282	4	Schraube WN1443_KB22x8	PART
26	3766003	4	Sechskantmutter DIN 934 - M 3	PART
27	315320	4	Senkkopfschraube mit Kreuzschlitz Form H	PART
28	352032	2	U-Scheibe DIN 125 - A 2.2	PART

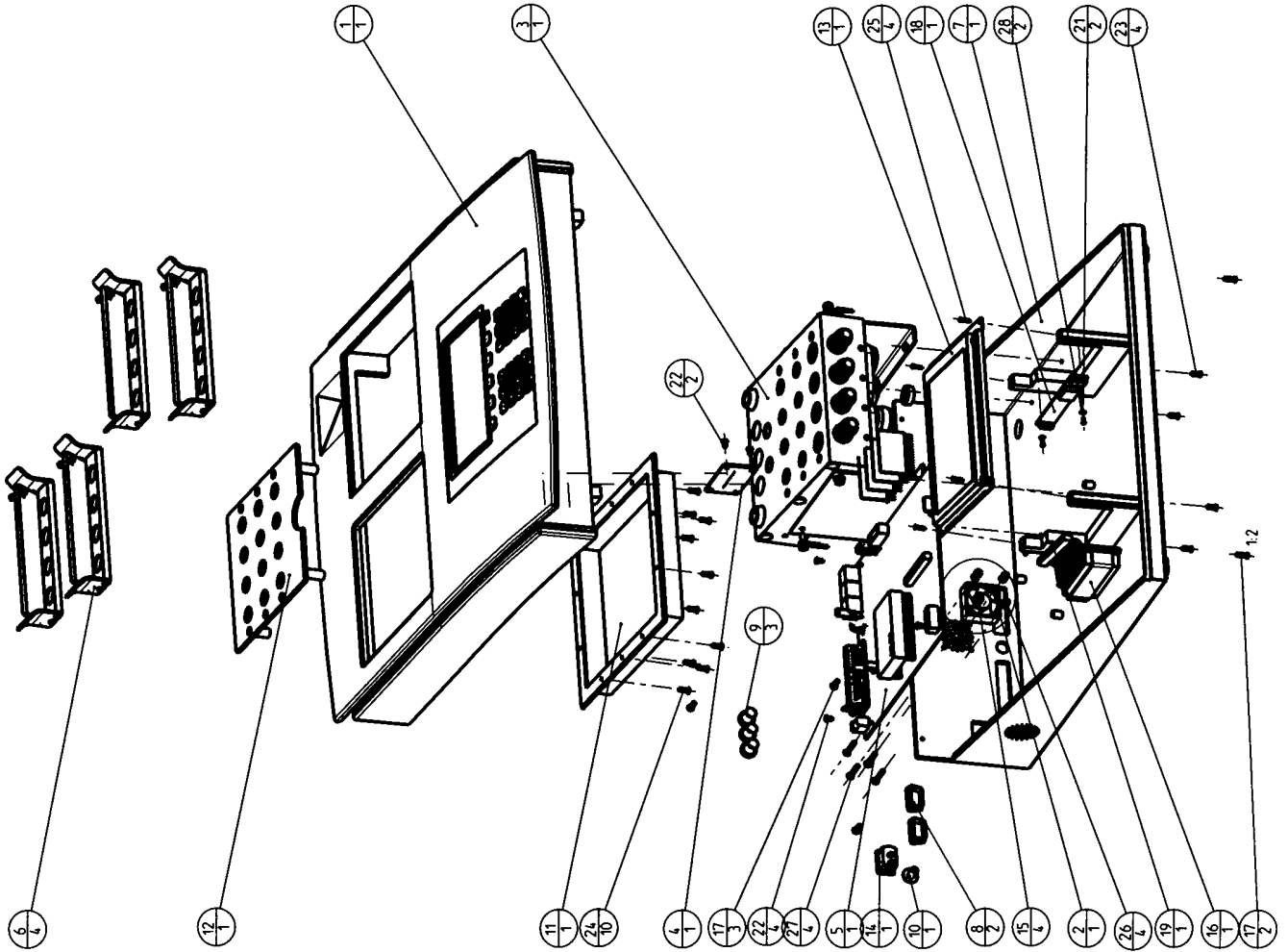

Glimmerscheiben beidseitig mit Wärmeleitpaste bestreichen

Pos	Art Nr	Menge	Benennung	Typ
1	111049	1	Riemenscheibe KC4A/KC10A Motor	PART
2	111070	3	Halter für Rührchen KC4	PART
3	113573	2	Pipettenhalterrohr KC4 Delta	PART
4	114520	1	Thermoblock KC4 Delta (Mikro)	PART
5	120020	4	Glimmerscheibe TO 220	PART
6	120021	4	Isolierbuchse IB6	PART
7	120506	1	Flachriemen 81.6x1.2x6mm	PART
8	120941	2	Blockträger KC4 Delta	PART
9	121505	1	Klemmlasche Temperatursicherung	PART
10	121562	1	Temperaturwächter P82 60 5	PART
11	122071	2	Abstandsbolzen M3L15	PART
12	211010	1	R1k NTC	PART
13	216061	4	Transistor IRF 540 TMOS E-FET	PART
14	234167	1	KK gg 1.3x320 R0 M4/Fsh 6.3	PART
15	234169	1	KK gg 1.3x130 R0 M4/Fsh 6.3	PART
16	241101	1	Motor RDM 42/12 G A2	PART
17	329303	1	Gew.-Stift M3x3 DIN 916 A2	PART
18	329406	6	Gew.-Stift DIN 916 M4x6 A2	PART
19	337310	2	Schraube DIN 912 - M 3 X 8	PART
20	337410	5	Schraube DIN 912 - M 4 X 10	PART
21	339306	8	Schraube M3x6 Din7985 PH vz	PART
22	341322	1	Kerbstift DIN 1474-3x22-SI	PART
23	350013	2	Seeger Greifring 63 x0.6	PART
24	351034	6	Scheibe DIN 125 3.2x7x0.5 Kst	PART
25	353045	2	Federring DIN 7980 - A 4	PART
26	355032	2	Faeherscheibe A3.2	PART
27	355043	1	Faeherscheibe A4.3	PART
28	370110	4	Kontermutter Sensor	PART
29	370450	4	Abstandsbolzen M3x8	PART
30	383113	4	Einpreßmutter M3	PART
31	391623	2	DIN 625 - 623-Z	PART
32	615194	1	Abdeckfolie Thermoblock KC4 Delta	PART
33	616010	6	Ausgleichspunkt	PART
34	N51201	1	Platine KC4 Delta HZ	ASSEMBLY
35	X10009	4	Sensor KC	PART
36	X10091	4	Messbecher Mikro KC4	ASSEMBLY

