

# **CUBESCAN**

BioCon-500™  
Bladder Volume Measurement System

## **Service Manual**

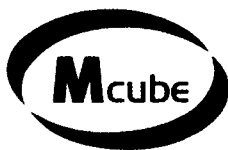

Man, Machine & Medicine  
**Mcube Technology Co., Ltd.**

# ***CUBESCAN***

BioCon-500™  
Bladder Volume Measurement System

## **Service Manual**



Man, Machine & Medicine  
**Mcube Technology Co., Ltd.**

**CUBEScan BioCon-500 Service Manual**

The Information contained in this service manual is proprietary to the Mcube Technology Co., Ltd. It is only used for convenience of our customers. It may not be changed in whole or in part without the written notice.

Any service work performed by persons who are not authorized by Mcube Technology Co., Ltd. may void your warranty.

This service manual contains technical contents for service as below.

- **Product configuration**
  - Product configuration and block diagram
  - Product components and their functions
  - Signal interface and their definition
- **Structure and assembling of the device**
  - Structure and components
  - Assembling sequence
- **Signal test**
- **Troubleshooting**
- **Circuit diagram**

**Table of Contents**

Contents	Page
<b>1. Product Configuration</b>	1
1.1. Product Configuration	1
1.2. Signal Interface	3
1.2.1. Signal Interface of Control Board	3
1.2.2. Signal Interface of Analog Board	9
1.2.3. Signal Interface of Keyboard	11
1.2.4. Signal Interface of Charging Board	12
<b>2. The Components of the Product</b>	13
2.1. DC Adapter	13
2.2. Ultrasonic Probe	13
2.3. Power Module	14
2.4. LCD Module	14
2.5. Printer Module	15
2.6. Charging Board	15
2.7. Analog Board	16
2.8. Control Board	18
<b>3. Structure and Assembling of the Device</b>	20
3.1. Structure and Assembling of the Upper Case	20
3.1.1. Structure and Components of the Upper Case	20
3.1.2. Assembling of the Upper Case	21
3.2. Structure and Assembling of the Lower Case	22
3.2.1. Structure and Components of the Lower Case	22
3.2.2. Assembling of the Lower Case	23
3.3. Frame Structure and Assembling of Ultrasonic Probe	24

3.3.1. Frame Structure and Configuration Chart of Ultrasonic Probe	24
3.3.2. Assembling of Ultrasonic Probe Frame	25
3.4. Structure and Assembling of Ultrasonic Probe	26
3.4.1. Structure and Configuration Chart of Ultrasonic Probe	26
3.4.2. Assembling of Ultrasonic Probe	29
<b>4. External Cable Configuration</b>	31
4.1. DC Adapter Cable	31
4.2. Ultrasonic Probe Cable	32
4.3. Serial Cable	33
4.4. USB Cable	34
<b>5. Signal Test</b>	35
5.1. Test for Analog board	35
<b>6. Troubleshooting</b>	39
<b>7 Maintenance Mode</b>	43
<b>8. Circuit Diagram</b>	46
8.1. Analog Board	46
8.2. Control Board	50
8.3. Charging Board	57
8.4. Connection Board	58
8.5. Keyboard	59

**1. Product Configuration**

**1.1 Product Configuration**

BioCon-500™ is a 3-dimensional ultrasonic equipment to measure the bladder volume and quantity of remaining urine safely and comfortably through non-invasive method. Its overall structure is as below.

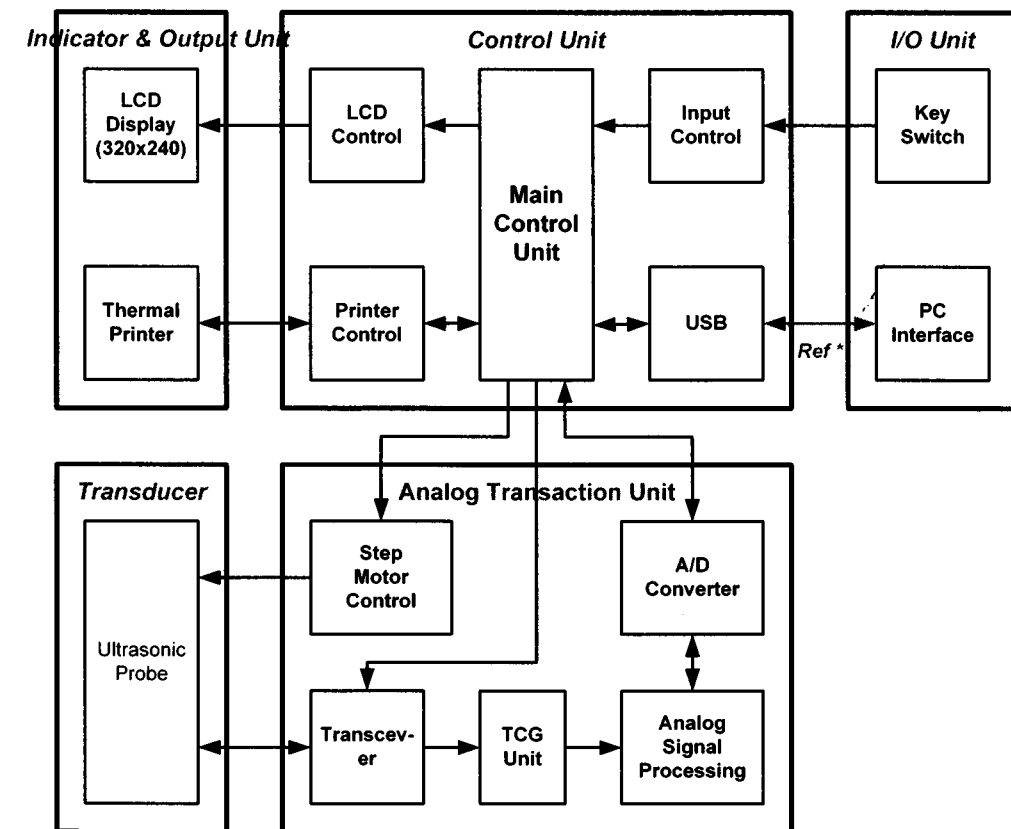

(System Configuration of BioCon-500)

The system, in large, consists of a system main body, an ultrasonic probe, and a DC adapter (power).

Component	Function
DC Adapter	Supplies a DC power required in a battery module for charging at a system main body.
Main Body	Controls system operation and various signals, and handles signal transmission and reception.

<b>Ultrasonic Probe</b>	Transmits and receives the ultrasonic signals, being used in close contact with the patient.
-------------------------	--

The system main body consists of a printer module, an LCD module, a battery module, and a number of boards. Its functions are as below.

Component	Function
<b>Charging Board</b>	Charges the battery module with DC 16V input from a DC adapter.
<b>Analog Board</b>	Transmits an ultrasonic pulse to the ultrasonic probe, which processes the signal just received and transmits the data transferred through the A/D converter to the control board. It also drives the stepping motor required in imaging.
<b>Connection Board</b>	Connects the analog board and the control board instead of wire.
<b>Keyboard</b>	Performs interfacing between the users and the system.
<b>Control Board</b>	Controls the overall system with following major functions. <ul style="list-style-type: none"> <li>- Processes user's input.</li> <li>- Drives the stepping motor of the thermal printer and transmits data</li> <li>- Controls the charging of a battery module</li> <li>- Interfaces PC through USB and serial port</li> <li>- Displays data on LCD</li> <li>- Processes data received from the analog board</li> </ul>
<b>Battery Module</b>	Provides the power required in the system.
<b>LCD Module</b>	Displays various information.
<b>Printer Module</b>	Prints the information about the bladder and bladder images in the thermal printer.

## 1.2 Signal Interface

The signal interface for the system is as below.

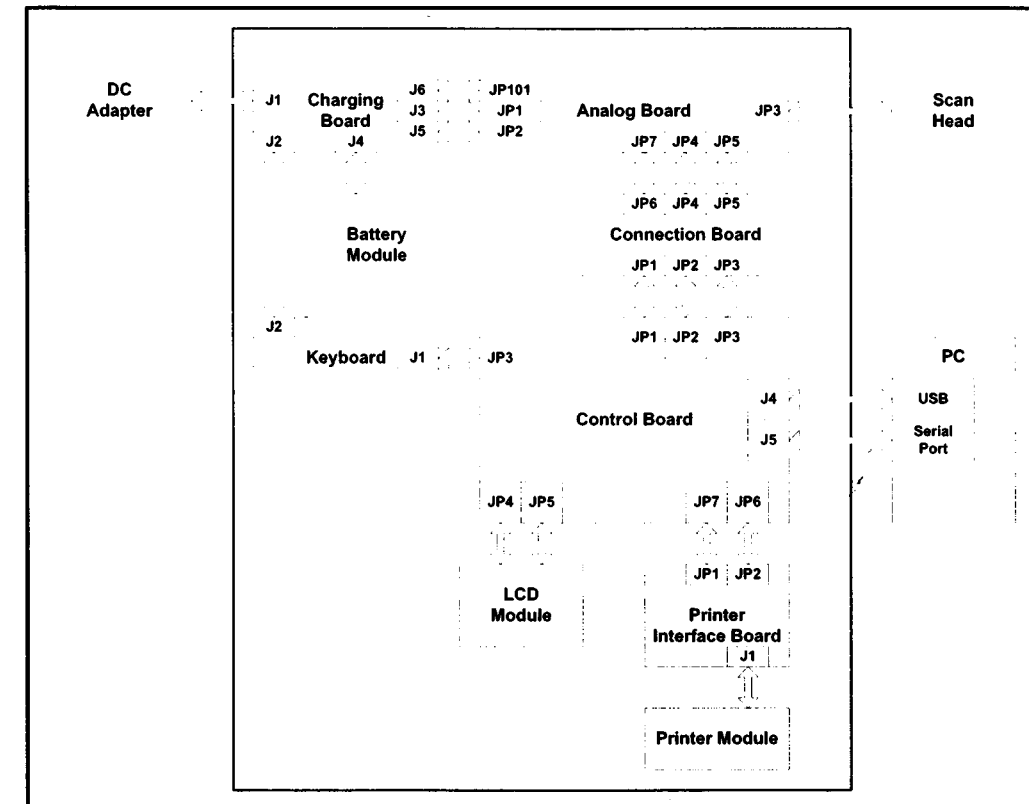

(Structure of Signal Interface at BioCon-500)

### 1.2.1 Signal Interface of Control Board

JP1 is a signal to exchange the data with ADC (Analog-Digital converter) in the analog board. And it is defined as below.

JP1			
TO:	Analog Board Connection		
Pin No.	Name	I/O	Description
1	FH_DB0	In	AD Conversion Data In bit 0
2	FH_DB1	In	AD Conversion Data In bit 1
3	FH_DB2	In	AD Conversion Data In bit 2
4	FH_DB3	In	AD Conversion Data In bit 3
5	FH_DB4	In	AD Conversion Data In bit 4

6	FH_DB5	In	AD Conversion Data In bit 5
7	FH_DB6	In	AD Conversion Data In bit 6
8	FH_DB7	In	AD Conversion Data In bit 7
9	FH_DB8	In	AD Conversion Data In bit 8
10	FH_DB9	In	AD Conversion Data In bit 9
11	FH_DB10	In	AD Conversion Data In bit 10
12	FH_DB11	In	AD Conversion Data In bit 11
13	FH_BLANK	Out	Blank signal
14	FH_AD_CS	Out	ADC chip select
15	FH_AD_RD	Out	ADC Read
16	FH_CONVST	Out	ADC Conversion Start
17	FH_AD_CLK	Out	ADC clock
18	FH_AD_BUSY	In	ADC busy
19	FH_POS_PULSE	Out	To generate positive pulse
20	PH_NEG_PULSE	Out	To generate negative pulse

JP2 is a signal to exchange the data with the stepping motor built in the ultrasonic probe.

And it is defined as below.

JP2			
To :	Analog Board Connection		
Pin No.	Name	I/O	Description
1	CH_MOT_PWR_ON	Out	Probe motor power on/off
2	FH_MOT_CON1	Out	Probe motor driver control signal
3	FH_MOT_CON2	Out	Probe motor driver control signal
4	FH_MOT_CON3	Out	Probe motor driver control signal
5	FH_MOT_CON4	Out	Probe motor driver control signal
6	FH_MOT_CON5	Out	Probe motor driver control signal
7	FH_MOT_CON6	Out	Probe motor driver control signal
8	FH_MOT_CON7	Out	Probe motor driver control signal
9	FH_MOT_CON8	Out	Probe motor driver control signal
10	FH_MOT_CON9	Out	Probe motor driver control signal

11	FH_MOT_CON10	Out	Probe motor driver control signal
12	FH_MOT_CON11	Out	Probe motor driver control signal
13	FH_MOT_CON12	Out	Probe motor driver control signal
14	FH_MOT_CON13	Out	Probe motor driver control signal
15	FH_MOT_CON14	Out	Probe motor driver control signal
16	FH_MOT_CON15	Out	Probe motor driver control signal
17	FH_MOT_CON16	Out	Probe motor driver control signal
18	H_PROBE_PWR	Power	Power for motor driving
19	H_PROBE_PWR	Power	Power for motor driving
20	Ground	Power	Ground signal

JP3 is a signal representing a power from the analog board and other various signals.

And it is defined as below.

JP3			
To :	Analog Board Connection		
Pin No.	Name	I/O	Description
1	SWITCHING_ON	Out	To say that control board is on.
2	CH_AN_PWR_ON	Out	Analog board power on/off
3	CH_SCLK	Out	Probe EEPROM serial clock
4	CH_SDI	In	Probe EEPROM serial data in
5	FH_SCAN_SW	In	Probe scan switch input
6	-	-	Not Used
7	CH_SDO	Out	Probe EEPROM serial data out
8	CH_ECS	Out	Probe EEPROM chip select
9	FH_SPARE3	-	Reserved.
10	FH_SPARE4	-	Reserved.
11	H_BAT_UNSWITCHED	Power	Input power from analog board
12	H_BAT_UNSWITCHED	Power	Input power from analog board
13	H_BAT_UNSWITCHED	Power	Input power from analog board
14	H_BAT_UNSWITCHED	Power	Input power from analog board
15	H_BAT_UNSWITCHED	Power	Input power from analog board
16	VDD	Power	ADC digital logic power
17	VDD	Power	ADC digital logic power
18	Ground	Power	Ground signal

19	Ground	Power	Ground signal
20	Ground	Power	Ground signal

JP4 is a connector to provide a driving power required in LCD backlight. And it is defined as below.

JP4			
TO:	LCD Backlight		
Pin No.	Name	I/O	Description
1	High	Out	AC high voltage
2	-	-	Not used
3	-	-	Not used
4	Low	Out	Ground

JP5 is a signal related to an LCD display and connected to an LCD module. And it is defined as below.

JP5			
TO:	LCD Module		
Pin No.	Name	I/O	Description
1	VD0	Out	Display data signal
2	VD1	Out	Display data signal
3	VD2	Out	Display data signal
4	VD3	Out	Display data signal
5	VM	Out	Display on/off signal
6	VFRAME	Out	Scan start-up signal
7	-	-	Not used
8	VLINE	Out	Data input latch signal
9	VCLK	Out	Data input clock signal
10	VCC	Power	Power supply for logic(+5V)
11	Ground	Power	Ground signal
12	VEE	Power	Power supply for LCD
13	VO	Power	LCD contrast adjust voltage
14	Ground	Power	Ground signal

JP6 and JP7, the connector terminals for the connection with the printer module, are signals for the driving of a stepping motor built in the printer module, for data latch, for data I/O, and for power. And they are defined as below.

JP6			
TO:	Printer Module		
Pin No.	Name	I/O	Description
1	FP_STROBE3	Out	Third strobe
2	FP_STROBE2	Out	Second strobe
3	FP_STROBE1	Out	First strobe
4	VP_LOGIC	Power	Logic voltage
5	FP_PRI_CLK	Out	Serial clock
6	FP_LATCH	Out	Latch
7	FP_PRI_DATA_IN	IN	Data input
8	PRT_PWR	Power	Dot-line voltage
9	PRT_PWR	Power	Dot-line voltage
10	SM4	Out	Fourth phase of stepper motor
11	SM3	Out	Third phase of stepper motor
12	SM2	Out	Second phase of stepper motor
13	SM1	Out	First phase of stepper motor

JP7			
TO:	Printer Module		
Pin No.	Name	I/O	Description
1	CO		Collector of photo-transistor
2	VF		Anode of photo-sensor
3	L-GND	Power	Ground for logic
4	PRT_PWR	Power	Dot-line voltage
5	PRT_PWR	Power	Dot-line voltage
6	FP_PRI_DATA_OUT	Out	Data output
7	FP_STROBE6	Out	Sixth strobe
8	FP_STROBE5	Out	Fifth strobe
9	FP_STROBE4	Out	Fourth strobe
10	P-GND	Power	Ground for dot-line
11	P-GND	Power	Ground for dot-line
12	P-GND	Power	Ground for dot-line
13	P-GND	Power	Ground for dot-line
14	TM	In	Thermistor first terminal (second is ground)



J3 is a connector for the connection with the keyboard, a user input device. And it is defined as below.

J3			
TO:	Keyboard		
Pin No.	Name	I/O	Description
1	POW_OUT	Out	For turn on/off power
2	POW_IN	In	For turn on/off power
3	-	-	Not used
4	-	-	Not used
5	SW1	In	Print key input
6	SW2	In	Scan key input
7	SW3	In	Up key input
8	SW4	In	Down key input
9	SW5	In	Right key input
10	SW6	In	Left key input
11	SW7	In	Enter key input
12	SW8	In	Power key input
13	-	-	Not used
14	-	-	Not used
15	VDD	Power	"+3.3V"
16	CK_LIGHT	In	Reserved
17	-	-	Not used
18	-	-	Not used
19	Ground	Power	Ground signal
20	Ground	Power	Ground signal

J4 is a connector for data exchange between PC and BioCon-500 through USB. The USB cable is the type-B. The signal is defined as below.

J4			
TO:	USB Interface		
Pin No.	Name	I/O	Description
1	NEOT	In	End of DMA transfer
2	D+	I/O	USB D+ line
3	D-	I/O	USB D- line
4	Ground	Power	Ground signal

J5 is a RS-232 communication connector that connects the Serial Port of PC and the system main body of BioCon-500. And its signal is defined as below.

J5			
TO:	Serial Interface		
Pin No.	Name	I/O	Description
1	TxD	Out	RS-232 output
2	RxD	In	RS-232 input
3	Ground	Power	Ground signal

### 1.2.2 Signal interface of Analog Board

JP1 is a (+) terminal of the battery module connected from the battery module to the analog board through the charging board. And its signal is defined as below.

JP1			
TO:	Charging Board		
Pin No.	Name	I/O	Description
1	BAT_POS	Power	Input power from charging board
2	BAT_POS	Power	Input power from charging board

JP2 is a (-) terminal of the battery module connected from the battery module to the analog board through the charging board. And its signal is defined as below.

JP2			
TO:	Charging Board		
Pin No.	Name	I/O	Description
1	BAT_NEG	Power	Ground for input power from charging board
2	BAT_NEG	Power	Ground for input power from charging board

JP101 is a signal to control ON/OFF of DC power supplied from the DC adapter to the charging board. And its signal is defined as below.

JP101			
TO:	Charging Board		
Pin No.	Name	I/O	Description
1	ANP_PWR_ON	Out	Analog board power on/off
2	EE+5V	Power	"+5V"

JP3 is a connector linked to the ultrasonic probe. And it consists of a signal for a driving of a stepping motor built in the ultrasonic probe, a signal for transmission and reception of the electric signals with ultrasonic oscillator, and a signal for reception of the input from the switch built in the ultrasonic probe. These signals are defined as below.

JP3			
TO:	Ultrasonic Probe		
Pin No.	Name	I/O	Description
1	Shield ground	Power	Cable shield
2	-	-	Not Connected
3	SCAN_SW & DATA	In	Scan switch input from probe (Grey)
4	EE+5V	Power	EEPROM +5V (Orange)
5	ANGLE1	Out	Step motor control signal (Red)
6	SCL	Out	Serial clock (Violet)
7	-	-	Not Connected
8	ANGLE2	Out	Step motor control signal (Blue)
9	-	-	Not Connected
10	ANGLE3	Out	Step motor control signal (White)
11	ANGLE4	Out	Step motor control signal (Black)
12	-	-	Not Connected
13	PLANE1	Out	Step motor control signal (Brown)
14	-	-	Not Connected
15	PLANE2	Out	Step motor control signal (Green)
16	PLANE3	Out	Step motor control signal (Pink)
17	PLANE4	Out	Step motor control signal (Yellow)
18	SIGNAL	I/O	Signal line (Coaxial +)
19	-	-	Not Connected
20	SIG_GND	Power	Signal ground (Coaxial Shield)

\*. JP4, JP5, JP7: Refer to JP2, JP3, and JP1 of Control Board, respectively.

1.2.3 Signal Interface of Keyboard

J1 is a signal to deliver the key input from the user to the control board. And it is defined as below.

J1			
TO:	Control Board		
Pin No.	Name	I/O	Description
1	POW_OUT	In	For turn on/off power
2	POW_IN	Out	For turn on/off power
3			
4			
5	SW1	Out	Print key output
6	SW2	Out	Scan key output
7	SW3	Out	Up key output
8	SW4	Out	Down key output
9	SW5	Out	Right key output
10	SW6	Out	Left key output
11	SW7	Out	Enter key output
12	SW8	Out	Power key output
13			
14			
15	VDD	Power	"+3.3V"
16	CK_LIGHT	Out	Reserved
17			
18			
19	Ground	Power	Ground signal
20	Ground	Power	Ground signal

J2 is an ON/OFF control signal of LED to display the status both of the DC adapter connection and of charging. And it is defined as below.

J2			
TO:	Charging Board		
Pin No.	Name	I/O	Description
1	ADAPTER_ON_ANODE		Adapter on LED anode
2	ADAPTER_ON_CATHODE		Adapter on LED cathode
3	FAST_CHARGE_ANODE		Fast charge anode
4	FAST_CHARGE_CATHODE		Fast charge cathode

1.2.4 Signal Interface of Charging Board

J1 is a power input signal from DC adapter. And it is defined as below.

J1			
TO:	DC Adapter		
Pin No.	Name	I/O	Description
1	ADAPTER+	Power	+16V input
2	ADAPTER-	Power	ground
3	-	-	Not Connected

J2 is an ON/OFF control signal of LED to display the status both of the DC adapter connection and of charging. And it is defined as below.

J2			
TO:	Keyboard		
Pin No.	Name	I/O	Description
1	ADAPTER_ON_ANODE		Adapter on LED anode
2	ADAPTER_ON_CATHODE		Adapter on LED cathode
3	FAST_CHARGE_ANODE		Fast charge anode
4	FAST_CHARGE_CATHODE		Fast charge cathode

J4 is a power signal connected to (+) and (-) terminals of the battery module. And it is defined as below.

J4			
TO:	Battery Module		
Pin No.	Name	I/O	Description
1	BATTERY+	Power	Battery module plus
2	BATTERY-	Power	Battery module minus

\*. J6, J3, J5: Refer to JP101, JP1, and JP2 of Analog Board, respectively.

2. The Component of the Product

2.1 DC Adapter

Supplies the DC power required in charging the battery module. And its specification is as below.

Section	Specification
Input	100 ~ 240V, 50~60Hz, 1.0 - 0.50 A
Output	+16V, 2.8A
Signal	(inner part)+, (outer part) -

(Specification of DC Adapter)

The power system supplied through DC adapter has the following connection configuration.

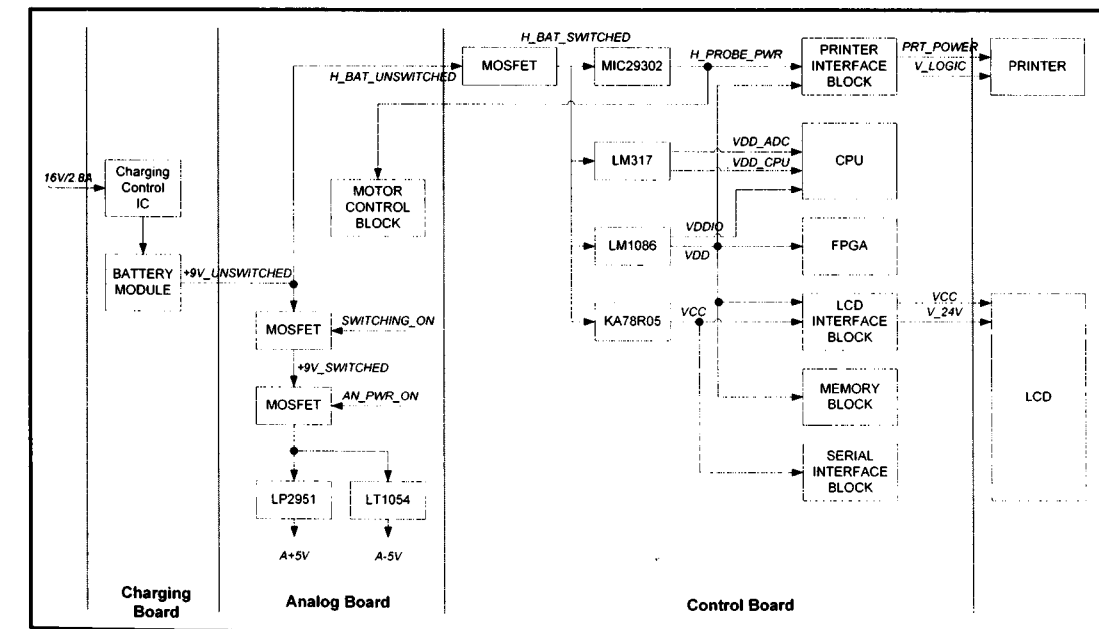

(Connection Configuration of Power Signal in BioCon-500)

2.2 Ultrasonic Probe

Transmits the ultrasonic pulse in close contacts with the patient's bladder and sends the received signals reflected from the human body to the analog board band. Ultrasonic probe consists of a transducer assembly, a motor used in adjusting the

location of a transducer assembly, and a switch board for receiving the scan start input from the user. The product specification is as below.

Section	Specification
Output Power	1mW maximum
The Arithmetic-mean Acoustic Working Frequency	2.8MHz
6dB beam area	5.85mm (H) 4.99mm (V)
The maximum value of the temporal average	0.0313 mW/cm <sup>2</sup>
Transducer Dimension	14mm diameter

(Specification of Ultrasonic Probe)

### 2.3 Power Module

Is a battery module to supply the power to the system. And its specification is as below.

Section	Specification
Battery	6 x 1.2V Ni-MH rechargeable batteries.
Thermostat	Open the battery module at 70 degrees

(Specification of Power Module)

### 2.4 LCD Module

Is a display device to display various information adjusted by the user. And its specification is as below.

Section	Specification
Display Resolution	320(W) x 240(H) (dots)
Dot Size	0.33(W) x 0.33(H) (mm)
Dot Pitch	0.36(W) x 0.36(H) (mm)
Display Type	FSTN (Black and White), Transmissive
Duty	1/240
Backlight	CCFT inverter

(Specification of LCD Module)

The actual picture of LCD module is as below.

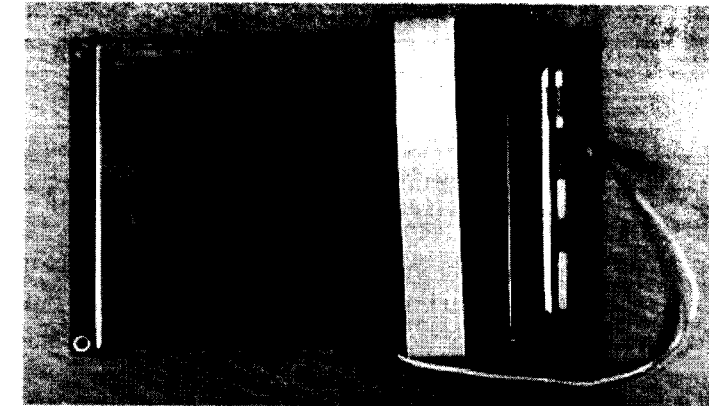

(Actual Picture of LCD Module)

### 2.5 Printer Module

A thermal printer to print out visualized bladder information and visual images. And its specification is as below.

Section	Specification
Printing Method	thermal dot line printing
Number of Dot per line	384
Printing Resolution	8 (dots/mm)
Paper Width	48 (mm)
Paper Roll Size	58 +0/-1(mm)

(Specification of Printer Module)

### 2.6 Charging Board

It charges the battery module with the DC power input from DC power adapter. The set-up of the jumper in the charging board is as below. SW1 and SW2 are used when the number of battery cells to be charged is set up. The number of cells in the battery module used in BioCon-500 is 6, where both SW1 and SW2 must be made open.

SW3 and SW4 are jumpers to set up the maximum charging time. The set-ups applicable in BioCon-500 are as below.

Maximum Charging Time (minute)	SW3	SW4
132	PGM2-BATT-	PGM3-REF
180	PGM2-REF	PGM3-BATT-
263	PGM2-BATT-	PGM3-BATT-

(Set-ups of the Maximum Charging Time: SW3 and SW4)

### 2.7 Analog Board

It transmits the ultrasonic pulse to ultrasonic probe, performs the signal process of signals received by the ultrasonic probe, and sends the data converted through the A/D converter to the control board. Also, it drives the stepping motor required in scanning. The block diagram of Analog board is as below.

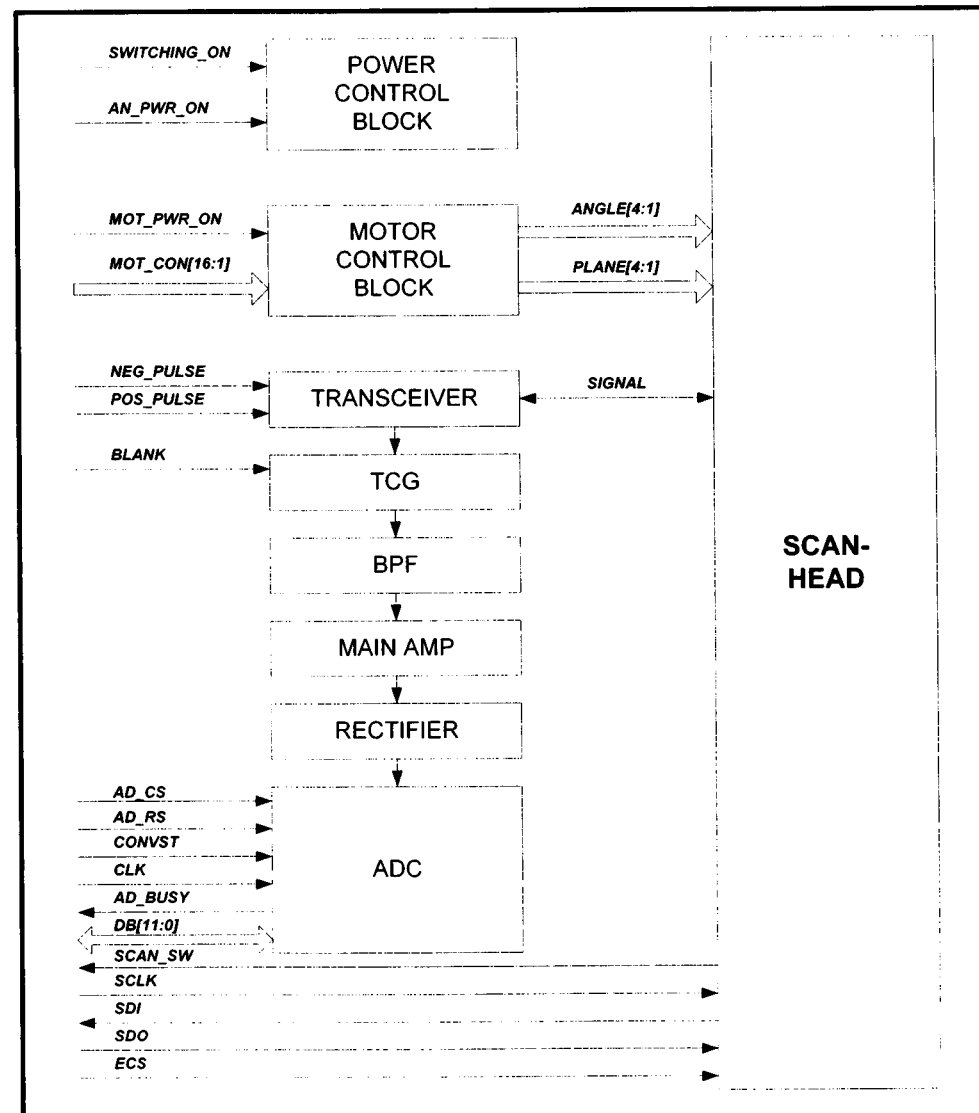

(Block Diagram of Analog Board in BioCon-500)

Each block of Analog board has following function.

Classification	Function
Power Control Block	Controls ON/OFF of power required in analog board and supplies the power required in each component.
Motor Control Block	A motor-driving module for the ultrasonic probe.
Transceiver	A module that generates the pulse required in the ultrasonic wave generation and receives the ultrasonic reflection signal from the ultrasonic probe.
TCG	TCG (Time Controlled Gain) block to impose Internal time-varied gain.
BPF	A band pass filter module to remove the undesired frequency signal other than the required signal.
Main Amp.	A main amplifier module to impose overall gain to the signal.
Rectifier	Rectifies the signal before A/D conversion.
ADC	Transmits the data to the control board by converting analog into digital.

**2.8 Control Board**

The control board is in charge of the signal for overall system and other various signals. And its configuration is as below.

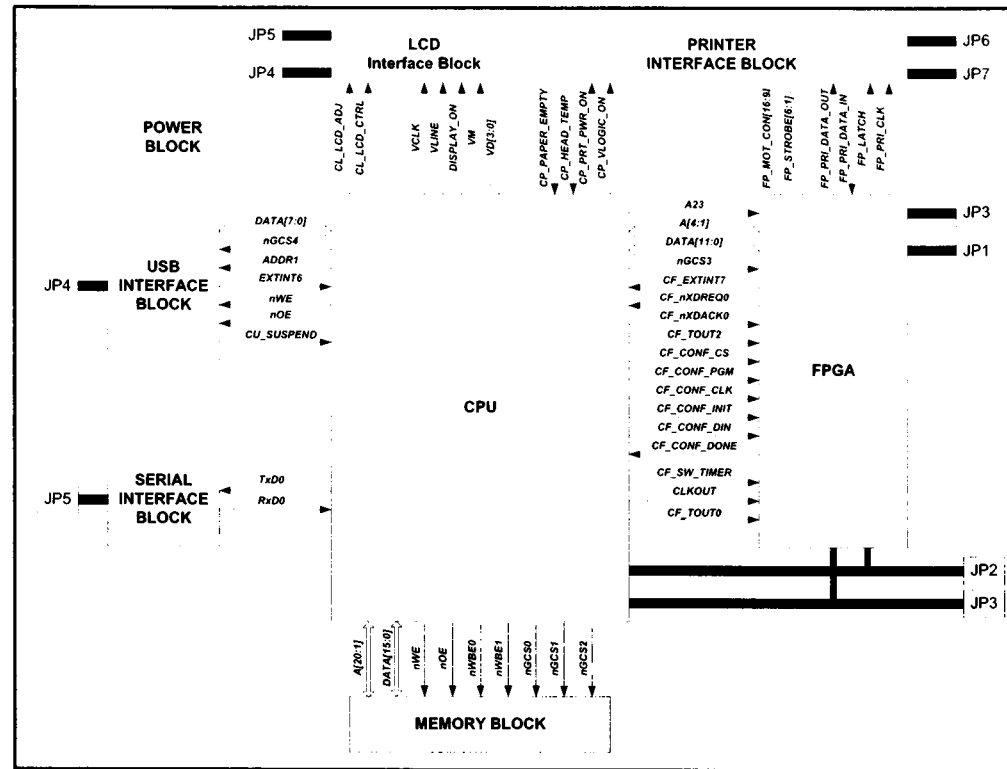

(Block Diagram of Control Board in BioCon-500)

The function of each module in the control board is as below.

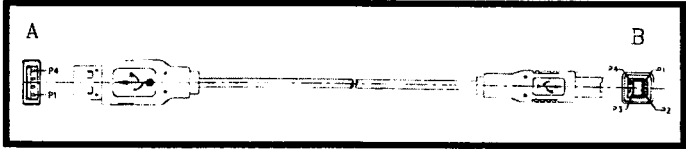
Classification	Function
Power Block	Supplies various powers required in control board.
USB Interface Block	Provides USB interface with PC and supports USB 1.1 full speed. The connector type is standard USB B type.  <Picture of USB cable>

Serial Interface Block	Provides serial interface with PC. The connection of BioCon-500 with PC is as below.			
	BioCon-500 (4 End Phone Jack)		PC (9 Pin D-SUB )	
	The first terminal from Jack end		Pin No.5	
	The second terminal from Jack end		-	
	The third terminal from Jack end		Pin No.3	
The fourth terminal from Jack end		Pin No.2		
(Connection of BioCon-500 main body with PC)				
Memory Block	The memory block has a control S/W and a display S/W and it includes RAM memory required in driving the control S/W.			
	Reference NO.	Capacity	Type	Purpose
	U1	8M bits	SRAM	RAM section
	U2	8M bits	Flash ROM	Control S/W
U3	8M bits	Flash ROM	Display S/W Data section	
(Configuration of memory)				
FPGA	A module performing such functions as chattering removal for key input by the user, serial data transmission to the thermal printer, motor control logic, and memory decoder.			
LCD Interface Block	Provides interface with LCD.			
Printer Interface Block	A module to drive motor of thermal printer.			

**3. Structure and Assembling of the Device**

**3.1 Structure and Assembling of the Upper Case**

**3.1.1 Structure and Components of the Upper Case**

The basic components forming the upper case of the device are printer module, LCD, and control switch. The basic structure is as below.

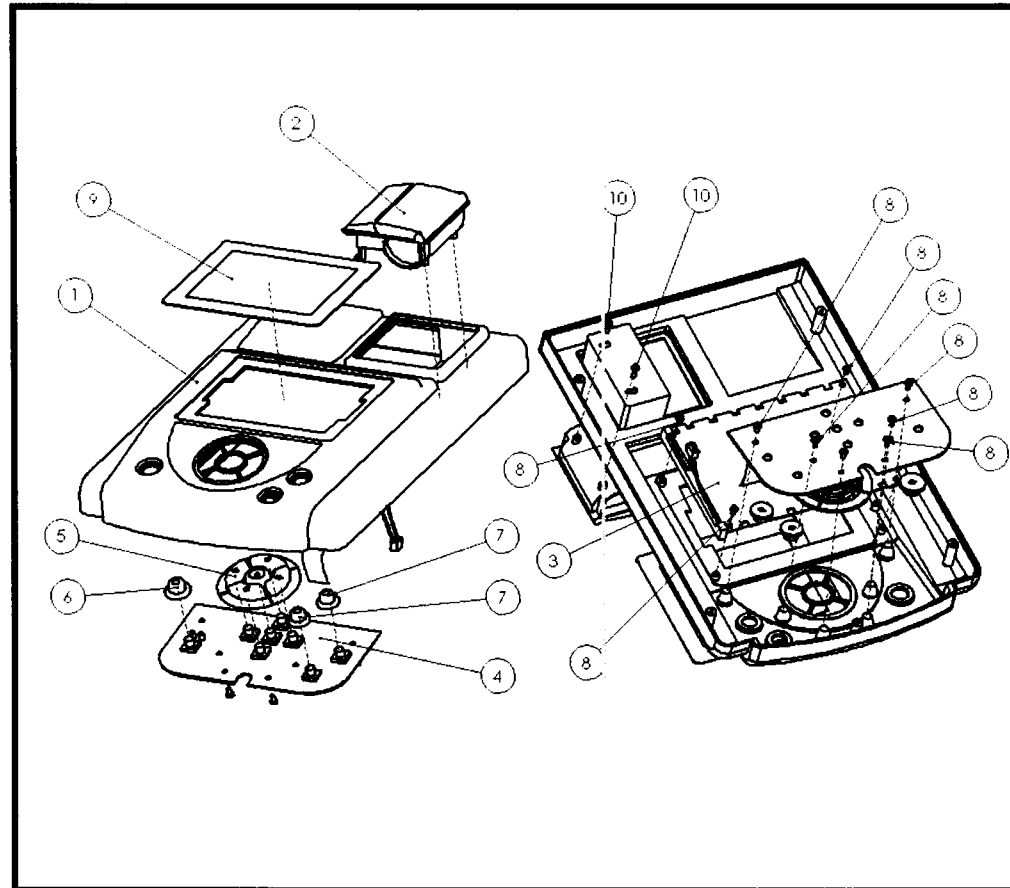

(Structure of the Upper Case of the Device)

The items forming the upper case of the device are as below.

No.	Name	Material	Q'TY
①	Radiation case	ABS	1EA
②	PRINT module		1EA
③	LCD module		1EA
④	Button PCB	ABS	1EA
⑤	Direction button (gray)	SILICONE	1EA

⑥	PWR button (red)	SILICONE	1EA
⑦	PRINT, SCAN button (blue)	SILICONE	2EA
⑧	M3 washer BOLT 8mm	STEEL	10EA
⑨	LCD window	PC 0.8T	1EA
⑩	M3 BOLT 12mm	STEEL	2EA

**3.1.2 Assembling of the Upper Case**

The assembling of the upper board takes the following steps, and the steps are reversed for the dissembling.

Order	Operation detail	Remark
1	Insert ⑤ direction button, ⑥ PWR button, and ⑦ PRINT(SCAN) button to fit in ④ button PCB.	
2	Attach button ④ PCB assembled by order 1 to ⑧ M3 washer in the front low of ① radiation CASE by using ⑧ M3 washer bolt. (X 6EA)	⑧ X 6EA
3	Attach the ③ LCD to the lower center of ① radiation CASE in the right direction.	⑧ X 4EA
4	Insert ② PRINT module to the grooves in upper part of the rear side, then attach from the lower part by using ⑩ M3 BOLT 12mm (X 2EA).	⑩ X 2EA
5	Remove the adhesive paper from the rear part of ⑨ LCD window and attach in the front center of ① radiation CASE.	

The actual picture of the assembled upper case is as below

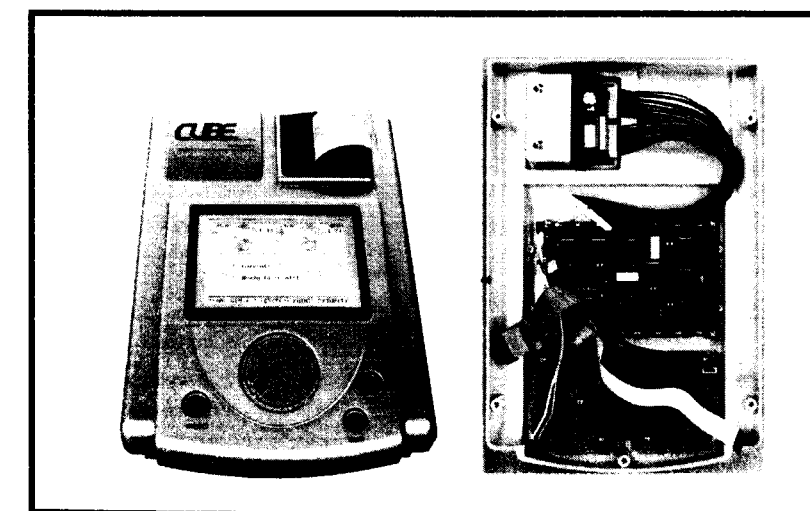

(The Actual Picture of the Assembled Upper Case)

**3.2 Structure and Assembling of the Lower Case**

**3.2.1 Structure and Components of the Lower Case**

The basic components constituting the lower case of the device are control PCB, analog PCB, charging PCB and battery. The basic structure is as below.

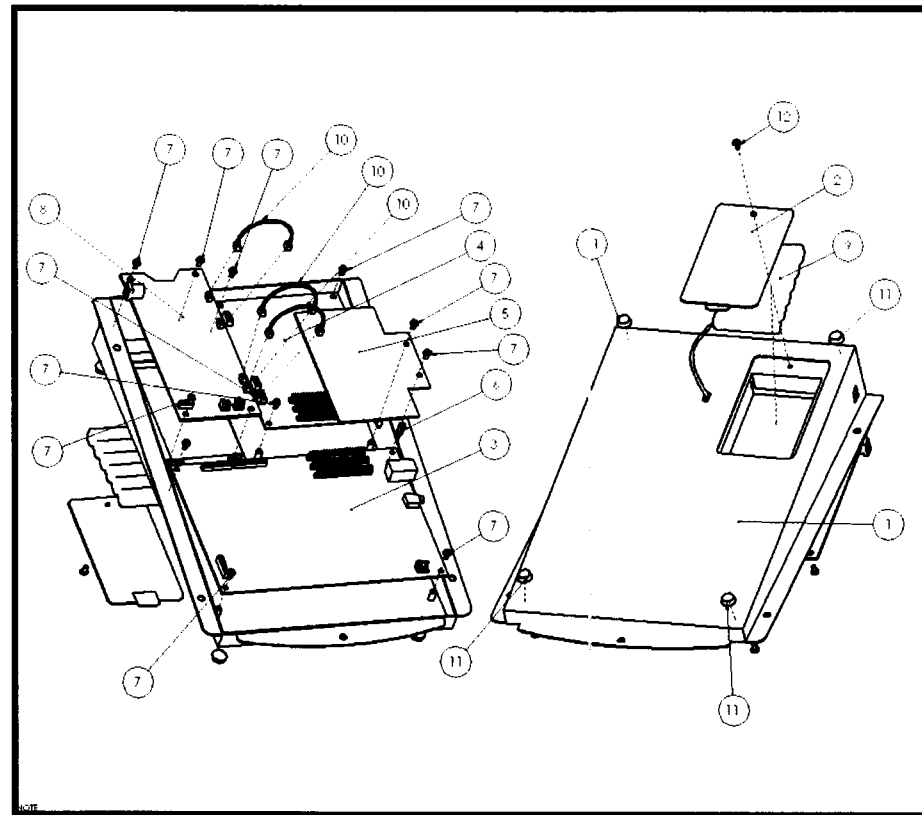

(Structure of the Lower Case of the Device)

The items constituting the lower case of the device are as below.

No.	Name	Material	Q'TY
①	Lower CASE	SPC	1EA
②	Battery bracket	SPC	1EA
③	Control PCB	PCB	1EA
④	Analog PCB	PCB	1EA
⑤	Connection PCB	PCB	5EA
⑥	Space BOLT		2EA
⑦	M3 Washer BOLT (8mm)	STEEL	12EA
⑧	Charging PCB	PCB	1EA

⑨	Battery Module (Li-MH)		1EA
⑩	Connector		3EA
⑪	Dustproof foot	SILICONE	4EA
⑫	M3 BOLT(6mm)	STEEL	1EA

**3.2.2 Assembling of the Lower Case**

The assembling of the lower board takes the following steps. And the steps are reversed for the disassembling.

Order	Operation Detail	Remark
1	Attach the ⑪ dustproof foot to ① lower CASE with proper distance from the lower CASE edge.	
2	Attach ③ control PCB, ④ analog PCB, and ⑧ charging PCB to ① metal-plate CASE by ⑦ M3 washer bolt.	⑦ X 9EA
3	At this time, the upper right of ③ control PCB and the lower right of ④ analog PCB must be attached by ⑥ space bolt.	⑥ X 2EA
4	Insert connector PCB into ③ control PCB and ④ analog PCB in the correct direction, and attach them by using ⑦ M3 washer bolt.	⑦ X 1EA
5	Connect ⑧ charging PCB and the connector of ④ analog PCB.	⑩ X 3EA
6	Insert ⑨ battery module into the lower part and connect it to ⑧ charging PCB.	
7	Cover ② metal-plate battery bracket and fix them by using ⑫ M3 plate bolt.	

The actual picture of the assembled lower case is as below.

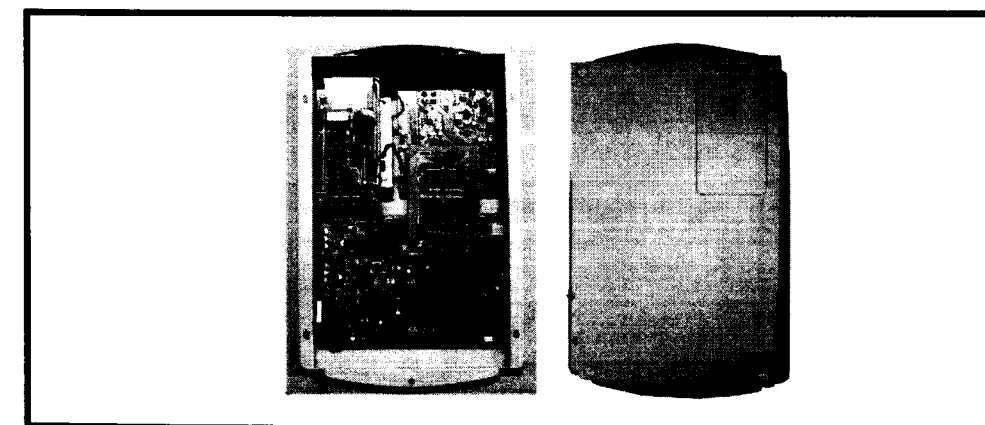

(The Actual Picture of the Assembled Lower Case)



**3.3 Frame Structure and Assembling of Ultrasonic Probe**

**3.3.1 Frame Structure and Configuration Chart of Ultrasonic Probe**

The basic components constituting the frame of the ultrasonic probe are a frame, a motor, a gear, and an ultrasonic oscillator. The basic structure is as below.

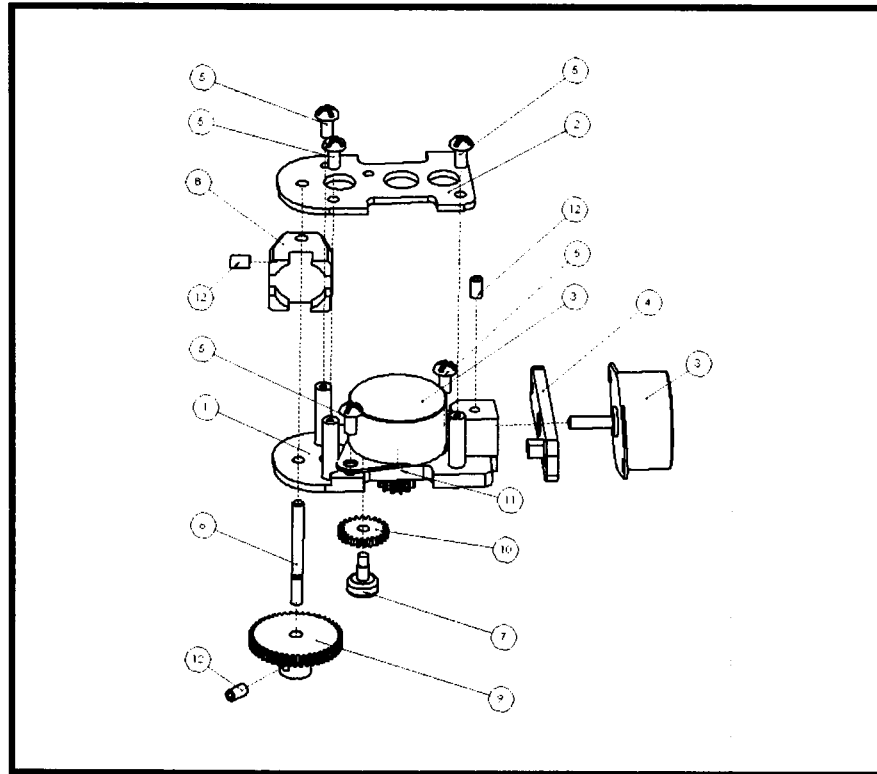

(The Structure of the Ultrasonic Probe Frame)

The items constituting the frame of the ultrasonic probe are as below.

No.	Name	Material	Q'TY
①	Main FRAME	ABS	1EA
②	Side FRAME	ABS	1EA
③	MOTOR	STEP MOTOR	2EA
④	MOTOR support	ABS	1EA
⑤	WASHER BOLT (M3 8mm)	Metal-plate BOLT	5EA
⑥	Oscillator Pin	STEEL	1EA
⑦	Gear Pin	ABS	1EA
⑧	Ultrasonic Oscillator	ABS	1EA

9	GEAR 48T	ACETYL	1EA
10	GEAR 24T	ACETYL	1EA
11	GEAR 12T	ACETYL	1EA
12	BOLT (M3 5mm)	Colored BOLT	3EA

**3.3.2 Assembling of Ultrasonic Probe Frame**

The assembling of the ultrasonic probe frame takes the following steps. And the steps are reversed for the disassembling.

Order	Operation Detail	Remark
1	Insert ⑩ gear 24T into ⑦ gear pin and insert them into ① MAIN FRAME, then fix them by gluing inside.	
2	Insert ⑪ Gear 12T into ③ MOTOR by indentation, then attach it by using ① MAIN FRAME and ⑤ M3 8mm WASHER BOLT.	
3	Insert ③ MOTOR into ① main frame by inserting ④ MOTOR support, then attach it by using ⑫ bolt.	
4	After indentation of ⑥ oscillation pin and ⑨ Gear 12T, fix them by using ⑫ BOLT(M3 5mm).	
5	Insert the parts assembled by order 4 into the center of ① MAIN FRAME and ② side FRAME across ⑧ oscillator by using ⑥ oscillator pin.	
6	After order 5, attach the oscillator by using ⑫ BOLT(M3 5mm).	

The assembled ultrasonic probe frame has the figure as below.

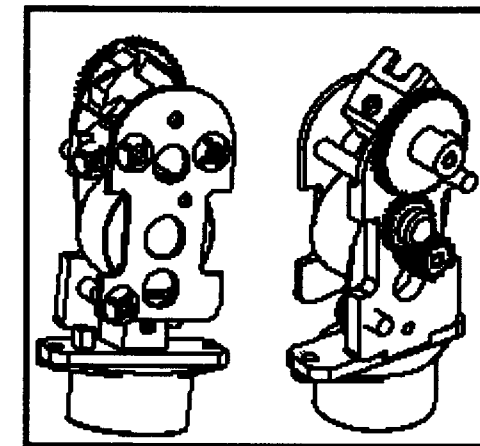

(The Figure of the Ultrasonic Probe Frame)

**3.4 Structure and Assembling of Ultrasonic Probe**

**3.4.1 Structure and Configuration Chart of Ultrasonic Probe**

Ultrasonic probe consists of probe frame, body, and cap. The basic structure is as below.

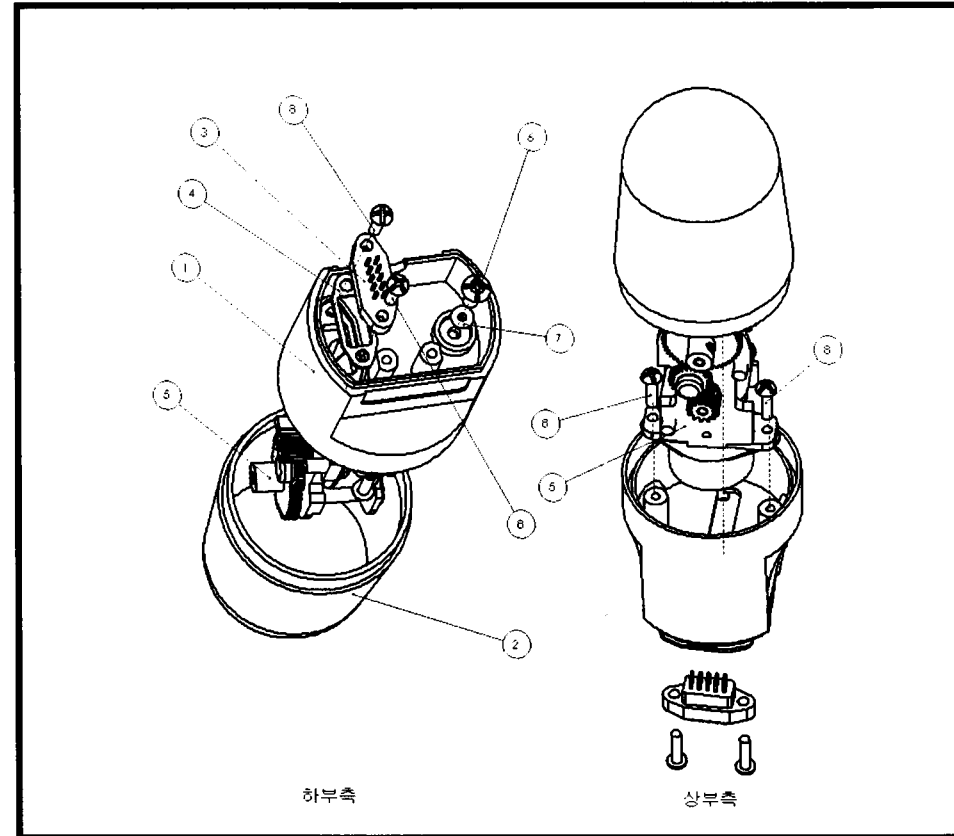

(The Structure of Ultrasonic Probe)

The items constituting the ultrasonic probe are as below.

No.	Name	Material	Q'TY
①	BODY	PC (LEXAN)	1EA
②	CAP	PC (LEXAN)	1EA
③	CONNECTER (10PIN)	PP	1EA
④	CONNECTER Gasket	SILICONE	1EA
⑤	FRAME Assembly	Metal-plate BOLT	1SET
⑥	M4 10mm BOLT	SUS	1EA
⑦	Rubber Ring	Rubber	1EA
⑧	M3 12mm BOLT	Metal-plate STEEL	4EA
⑨	Mineral Oil, White, Heavy	ALD	100cc

The lower part of the ultrasonic probe where the ultrasonic probe and BioCon-500 are connected is formed as below.

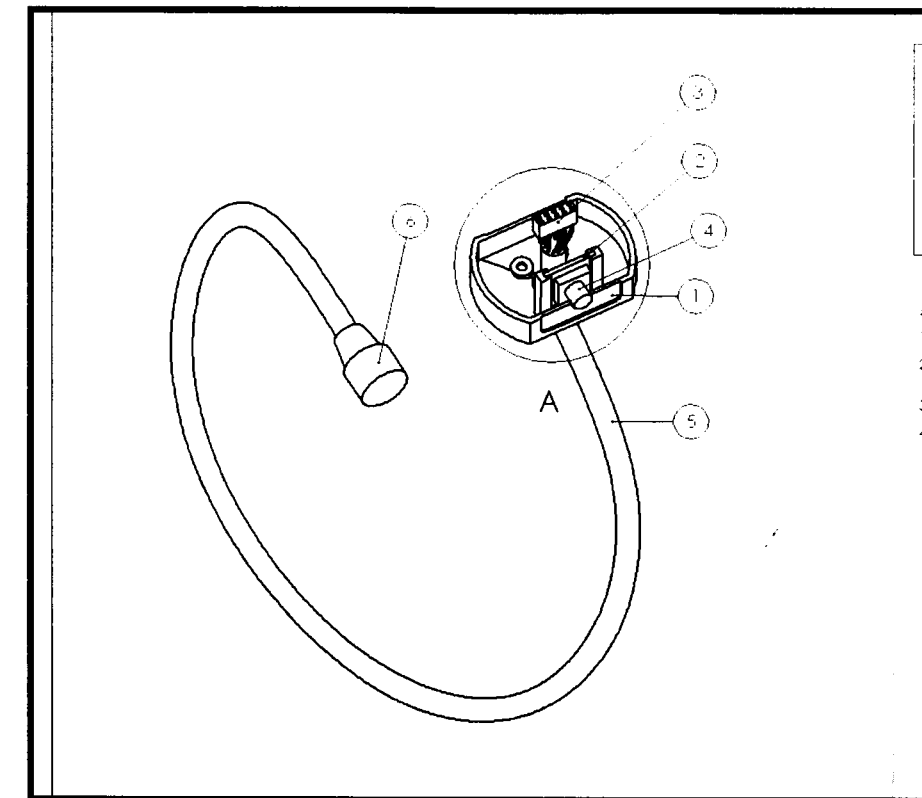

(The Structure of the Lower Part of the Ultrasonic Probe)

The items constituting the lower part of the ultrasonic probe are as below.

Product No.	Component Name	Raw Materials	EA
①	Lower BODY	PC (LEXAN)	1EA
②	Button PCB	PCB	1EA
③	10PIN CONNECTOR	CONNECTOR	1EA
④	Switch	ABS	1EA
⑤	SHIELD WIRE	WIRE	1500mm
⑥	20PIN CONNECTOR	CONNECTOR	1EA

The cable structures of above ③, ④ and ⑥ are as below.

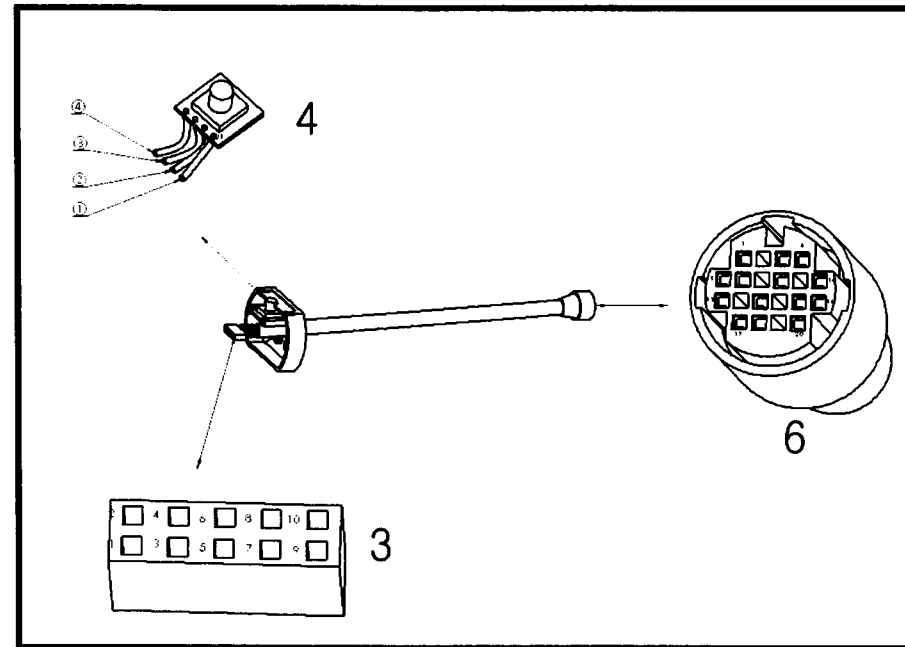

(PIN configuration of connector ③, ④, and ⑥ connectors )

These connectors and signals of these pins are defined as below.

⑥ (Pin No.)	③ (Pin No.)	④ (Pin No.)	Color	Description
1		SW4		Cable shield
2			-	Not Connected
3		SW2	gray	Scan Switch input from probe
4		SW1	orange	EEPROM +5V
5	2		red	Control signal for step motor
6		SW3	violet	Serial Clock
7			-	Not Connected
8	1		blue	Control signal for step motor
9			-	Not Connected
10	4		white	Control signal for step motor
11	3		black	Control signal for step motor
12			-	Not Connected
13	10		brown	Control signal for step motor
14			-	Not Connected
15	9		green	Control signal for step motor
16	8		pink	Control signal for step motor
17	7		yellow	Control signal for step motor
18	6			Signal line (Coaxial +)
19			-	Not Connected
20	5			Signal ground (Coaxial shield)

The structure of the ultrasonic probe with its lower part is as below.

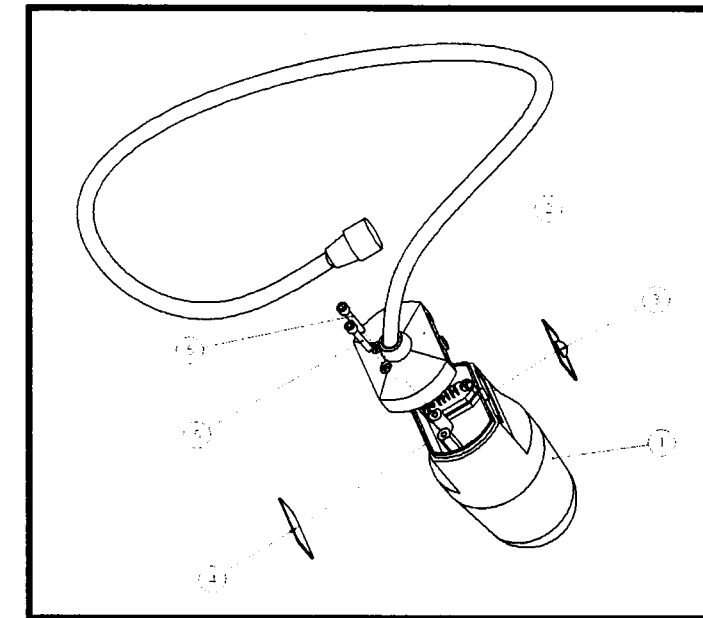

(The Structure and Connection of Ultrasonic Probe)

The items constituting the ultrasonic probe are as below.

No.	Name	Material	Q'TY
①	PROBE Assembly SET		1SET
②	PROBE lower Body SET		1SET
③	Sheet for Scan Button	PC	1EA
④	Sheet for S/N	PC	1EA
⑤	BOLT M3 20mm	STEEL	2EA

### 3.4.2 Assembling of Ultrasonic Probe

The assembling of the ultrasonic probe takes the following steps. And the steps are reversed for the disassembling.

Order	Operation Detail	Remark
1	Insert ④ connector gasket and ③ connector into ① lower body and fit them in Body groove.	
2	Assemble 2 ea of ⑤ M3 12mm bolt in 2 locations.	⑧ X 2EA
3	Assemble 2 ea of ⑧ M3 12mm bolt in 2 locations of ⑤ frame set assembled in the upper part of ① body. At this time, insert connector located in ⑤ FRAME	⑧ X 2EA

	SET PCB and ③ CONNECTOR in the right direction.	
4	Put appropriate amount of strong adhesives in the groove of the upper part of ① body and attach with ② CAP. Press for longer than 5 hours after attaching to harden.	
5	After a certain time, insert 100cc of mineral oil and assemble by using ⑦ Rubber ring and ⑥ M4 bolt.	

- \* The cautions during assembling are as below.
- Do not impose too much force when connecting.
  - Take caution not to have any oil leakage.

The assembling of the lower part of the ultrasonic probe takes the following steps. And the steps are reversed for the disassembling.

Order	Operation Detail	Remark
1	Cut ⑤ SHIELD WIRE in 1500mm and operate terminal process appropriately for both ends.	
2	Solder 4 of ⑤ Shield Wire lines (Refer to PIN number) in ② PCB equipped with ④ switch.	
3	Insert the remaining 10 ⑤ Shield Wire lines in ③ 10PIN CONNECTER. (Refer to PIN number)	
4	Insert 16 PIN of other side in ⑥ 20PIN connector and assemble the connector.	

The final assembling of the ultrasonic probe is processed in the following order, and the disassembling in the counter order.

Order	Operation Detail	Remark
1	Assemble the lower part of Probe ① assembly set and ② probe body set by using ⑤ ranch bolt.	
2	After order 1, attach S/N sheet to the opposite side of SCAN sheet where the button is located.	

The actual picture of the assembled ultrasonic probe is as below.

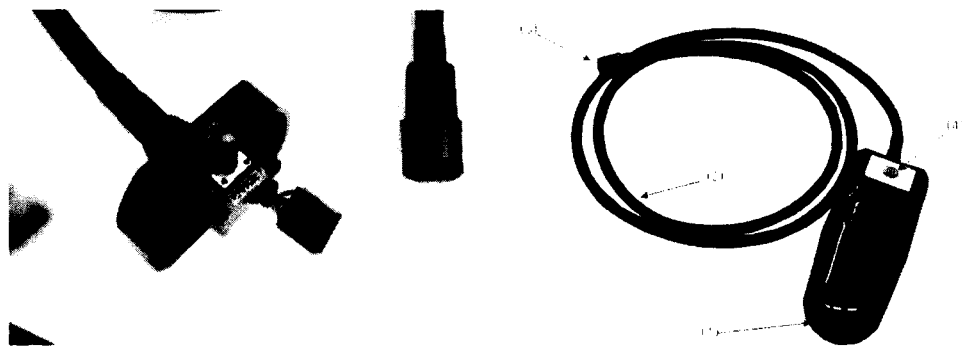

(The Actual Picture of the Assembled Ultrasonic Probe)

#### 4. External Cable Configuration

The external cable constituting BioCon-500 consists of the connection with DC adapter, the connection with ultrasonic probe, the connection with Serial port of PC, and the cable for the connection with USB of PC.

- DC adapter cable
- Ultrasonic probe cable
- Serial cable
- USB cable

##### 4.1 DC Adapter Cable

DC adapter supplies DC power required in battery module for the system operation by the battery in BioCon-500™. It supplies the power to BioCon-500™ from the DC adapters through a cable as below.

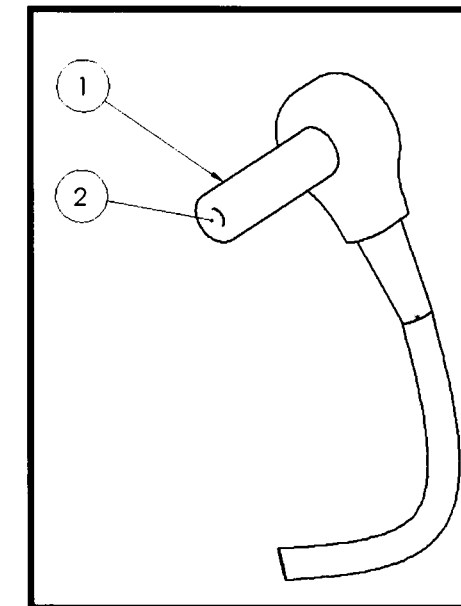

(DC Adapter Cable)

The signal of DC adapter cable is defined as below.

Pin No.	Description
1	Ground
2	+16V input

(Pin Configuration of DC Adapter Cable)

**4.2 Ultrasonic Probe Cable**

The cable between the main body of BioCon-500™ and ultrasonic probe consists of transmission and reception of ultrasonic signals, motor control, and user input signals as the following structure. In the figure below, 1 is a terminal connected to the main body of BioCon-500™, while 2 and 3 are the terminals located within the probe.

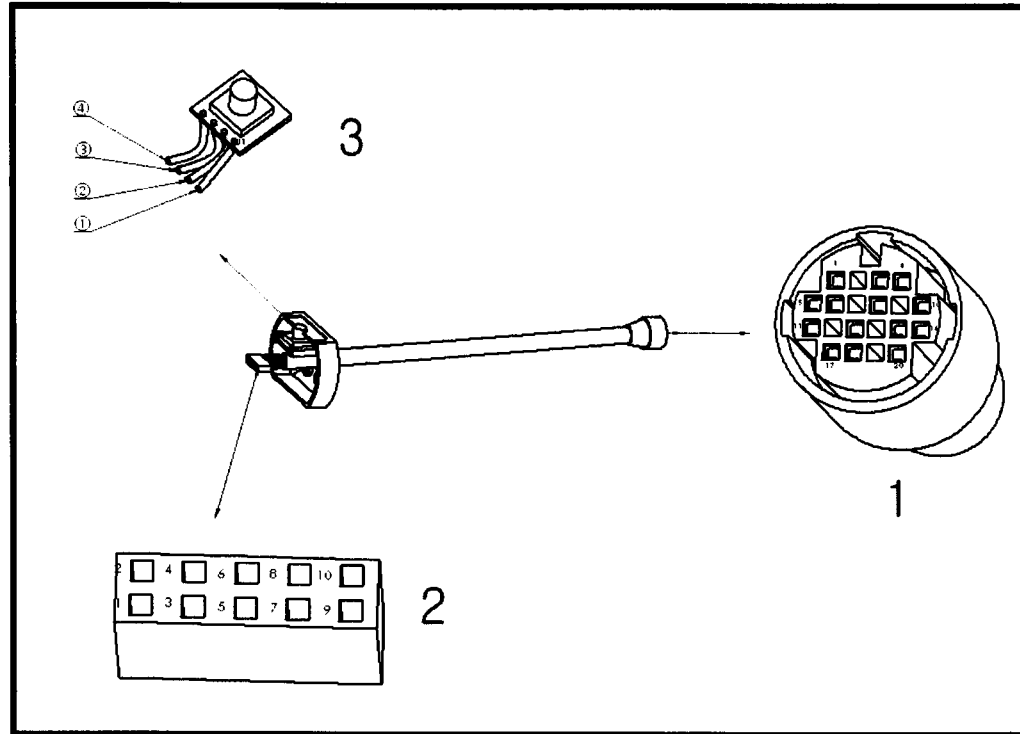

(Configuration of the Ultrasonic Probe Cable)

The signal configuration at the ultrasonic probe cable is as below.

① (Pin No.)	② (Pin No.)	③ (Pin No.)	Color	Description
1		SW4		Cable shield
2			-	Not Connected
3		SW2	grey	Scan Switch input from probe
4		SW1	orange	EEPROM +5V
5	2		red	Control signal for step motor
6		SW3	violet	Serial Clock
7			-	Not Connected
8	1		blue	Control signal for step motor
9			-	Not Connected
10	4		white	Control signal for step motor
11	3		black	Control signal for step motor
12			-	Not Connected
13	10		brown	Control signal for step motor

14			-	Not Connected
15	9		green	Control signal for step motor
16	8		pink	Control signal for step motor
17	7		yellow	Control signal for step motor
18	6			Signal line (Coaxial +)
19			-	Not Connected
20	5			Signal ground (Coaxial shield)

(Pin Configuration of the Ultrasonic Probe Cable)

(Reference)

- ① Cable terminal connected to the main body of BioCon-500
- ② Cable terminal connected to the ultrasonic probe
- ③ Terminal connected to the switch within the ultrasonic probe

**4.3 Serial Cable**

It is for connection between the main body of BioCon-500 and the serial port of PC, and can be used to download the operation software for BioCon-500 from PC. The structure is as below.

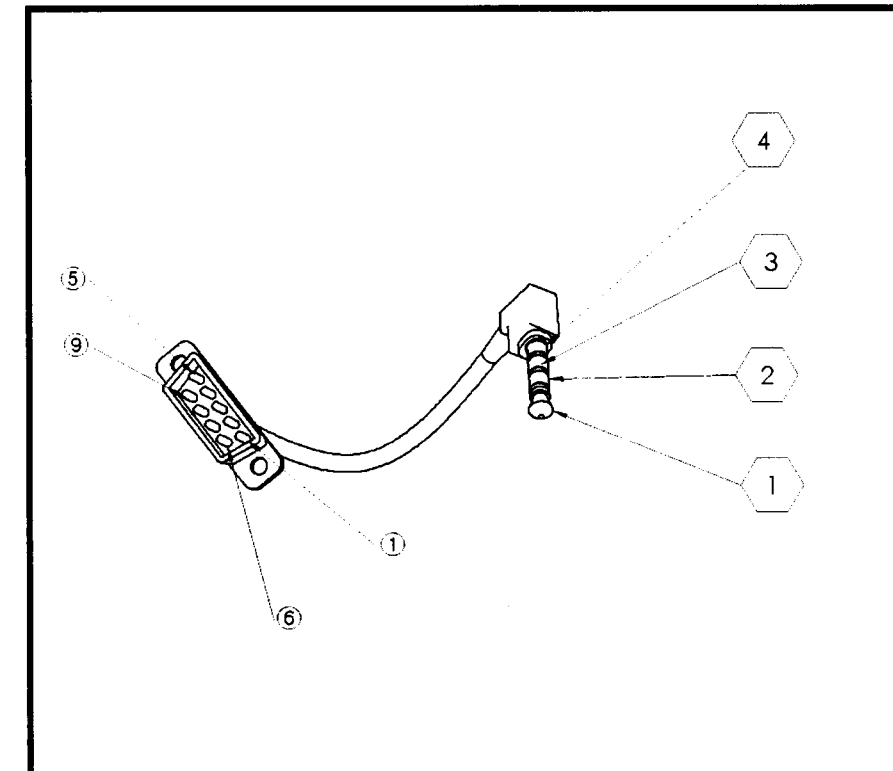

(Configuration of Serial Cable)

The signal configuration of Serial Cable is as below.

Pin No. (BioCon-500)	Pin No. (9Pin D-SUB)	Description
1	5	Signal Ground
2	-	
3	3	TxD (RS-232 output)
4	2	RxD (RS-232 input)

(Pin Configuration of Serial Cable)

**4.4 USB Cable**

Data exchange between the main body of BioCon-500 and PC is made through the USB. The terminals of BioCon-500 and of PC are USB B-type connector and USB A-type connector, respectively. And its figure is as below.

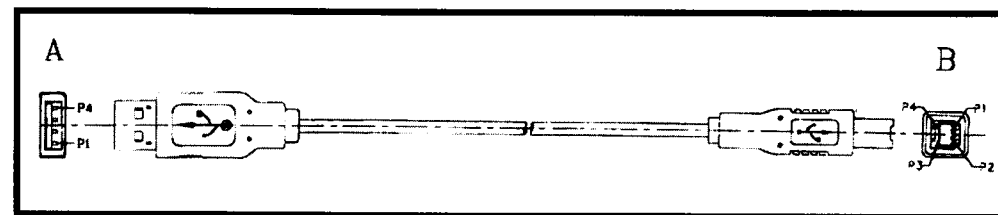

(USB Cable: Connection between BioCon-500 and PC)

USB B-type terminal of BioCon-500 and USB A-type terminal of PC are connected in signal colors as below.

USB A-TYPE	Wire Color	USB B-TYPE
1	RED	1
2	WHITE	2
3	GREEN	3
4	BLACK	4
Case	SHEEL	Case

(Pin Configuration of USB Cable)

**5. Signal Test**

**5.1 Test for Analog Board**

To check and test the signal of the analog board, following measurement devices are required.

- Digital multi-meter
- Digital oscilloscope
- Function generator

Test the analog board by checking the signal with above measurement devices in the following order.

- ① Test the power for below location.

Location	Measured Value
TP1 & U17.8	+5V (+/- 5%)
TP1 & '-' terminal of C48	-5V (+/- 5%)
TP1 & terminal '+' of C104	+7.5V ~ 8V

- ② Set up Function Generator as below.

Item	Setup Value
Frequency	2.8 [MHz]
Amplitude	20 [mVpp]

- ③ Connect the black wire of Function Generator to TP1, and the red wire to TP7.
- ④ Turn on the power.
- ⑤ Turn on the signal output of Function Generator.
- ⑥ Set up time scale of Oscilloscope in 1us.
- ⑦ Measure the peak-to-peak power of JP6.9. (Power scale is 200mV)

Item	Measured Value
Vpp @JP6.9	> 600 [mVpp]

- ⑧ Set up Function Generator as below.

Item	Measured Value
Frequency	2.8 [MHz]
Amplitude	6 [mVpp]

⑨ Measure the peak-to-peak voltage of JP6.11 and JP6.13. (Voltage scale is 1V)

Item	Measured Value
Vpp @JP6.11	> 4.5 [Vpp]
Vpp @JP6.13	> 4.0 [Vpp]

⑩ TCG block test

(a) TCG1

- Set up Oscilloscope as below and connect the probe to JP6.6.

Item	Setup Value
Axis of Voltage	0.5 [V]
Axis of Time	2 [us]
Trigger Level	+500 [mV]
Trigger Method	Single Shot

- Press the scan button of BioCon-500 to measure the rising period of the voltage measured with Oscilloscope from 0.5V to 1.5V. The measurement signal is measured in the following figure.

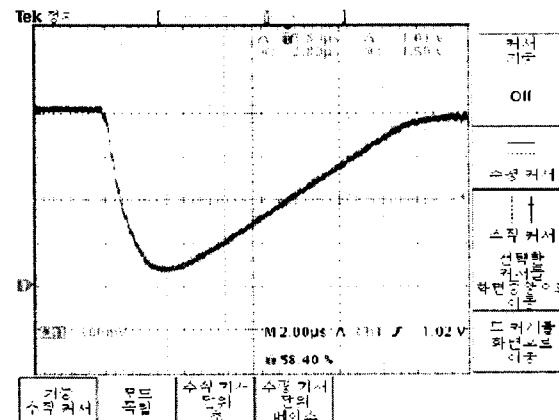

(The Figure of TCG1 Measurement Signal)

- At this time, the value during the rising period must be measured as below.

Item	Measured Value
Rising Time	5.5 ~ 6.1 [us]

(b) TCG2

- Set up Oscilloscope as below and connect the probe to JP6.7.

Item	Setup Value
Axis of Voltage	0.5 [V]
Axis of Time	40 [us]
Trigger Level	+500 [mV]
Trigger Method	Single Shot

- Press the scan button of BioCon-500 to measure the rising period of the voltage measured with Oscilloscope from 0.5V to 1.5V. The measurement signal is measured in the following figure.

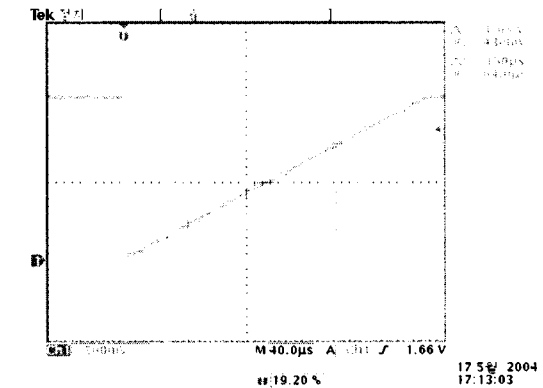

(The Figure of TCG2 Measurement Signal)

- At this time, the value during the upward period must be measured as below.

Item	Measured Value
Rising Time	142 ~ 158 [us]

⑪ Measurement of the ultrasonic pulse

- Set up the Oscilloscope as below and connect the probe to TP6.

Item	Setup Value
Axis of Voltage	10 [V]
Axis of Time	200 [us]
Trigger level	+10 [V]
Trigger Method	Single Shot

- Test the voltage shape measured by Oscilloscope by pressing the Scan button of BioCon-500. The signal is measured as figure below.

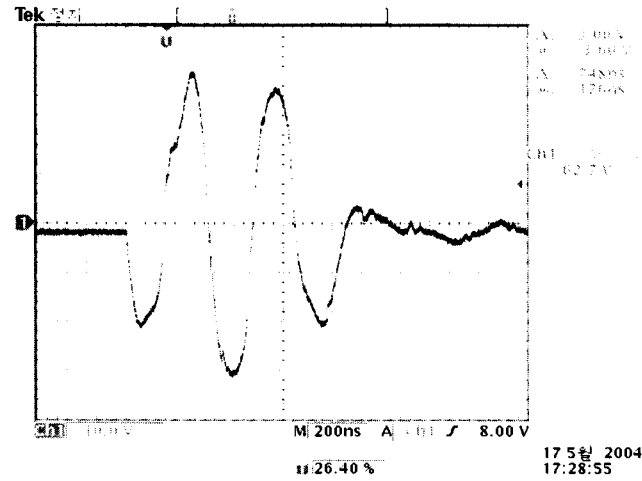

(Figure of the Ultrasonic Pulse Signal)

- The peak-to-peak voltage at TP6 must be measured in the following scope.

Item	Measured Value
Vpp @TP6	50 ~ 70 [V]

## 6. Troubleshooting

### 6.1 System is not turned on.

No.	Check point	Description
1	Is POWER key pressed for more than 1 second?	The system operates when pressing the POWER key for more than 1 second.
2	Measure the voltage of battery module.	More than +7V
3	Is battery module connected?	If not connected, connect the battery module.
4	Is the connector connected between keyboard and control board?	Connect the connector between two boards.
5	Not solved yet?	Exchange the control boards

### 6.2 System is not turned off.

No.	Check point	Description
1	Is POWER key pressed more than 1 second?	The system operates when pressing POWER key for more than 1 second.
2	Is the system not turned off even when pressing the Power key for more than 1 second?	Turn the power off by removing the battery module from the system. And exchange control boards.

### 6.3 Initial screen is not displayed when turning the system on.

No.	Check point	Description
1	Is backlight on in LCD?	Check if the connector for backlight of LCD is connected properly.
2	Is the FPC connector to the LCD module well connected?	Check if the connector is connected properly.
3	Check the voltage between the Control board ground and 12 <sup>th</sup> pin of JP5.	Check if -22V (+/-1V).
4	Check the voltage between the Control board ground and 13 <sup>th</sup> pin of JP5.	Check if -21V (+/-1V).
5	Is the system turned off?	Try again after replacing the LCD module.
6	The system is not turned off.	Test again after replacing the Control board.



**6.4 The green LED is not turned on even when the power adapter is connected.**

No.	Check point	Description
1	Is green LED not turned on even when the system is OFF?	Yes ->Refer to item 2. No -> Refer to item 4
2	Is the 4 pin connector connecting the Keyboard and Charging board connected?	Check the connection status and if not connected, connect 4 pin connector.
3		Replace charging board.
4	Green LED is on when the system is OFF, but it is turned off when the system is ON.	No problem. Because of charging control in Control board sometime Green LED is off when system is on.

**6.5 NO SCANHEAD message is displayed during scanning.**

No.	Check point	Description
1	Is the ultrasonic probe connected well to the main body?	If not, NO SCANHEAD message is displayed when the scan button is pushed.
2	Is open between the 3 <sup>rd</sup> and 6 <sup>th</sup> pin of the probe connector?	Test again after replacing with other ultrasonic
3	The message is displayed when the 3 <sup>rd</sup> and 6 <sup>th</sup> pin of Probe connector is short	Request service from the headquarter

**6.6 NO PAPER message is displayed during printing.**

No.	Check point	Description
1	Does printer module have thermal paper?	If not, insert thermal paper.
2	Does message still appears even when there is paper?	Try again after replacing the control board.

**6.7 The system is turned off while in use.**

No.	Check point	Description
1	Is auto power-off on in the setup menu of Maintenance mode?	When auto power-off function is active, system will be turned off if no key input is made during the fixed time.
2	Is the system turned off with the message of "BATTERY LOW, SYSTEM WILL BE TURNED OFF"?	Turn off the system to protect the battery module if the power is insufficient. Try again after charging.

**6.8 No image is displayed after scanning.**

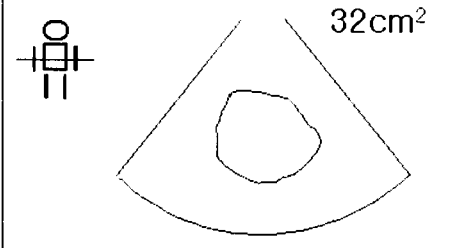
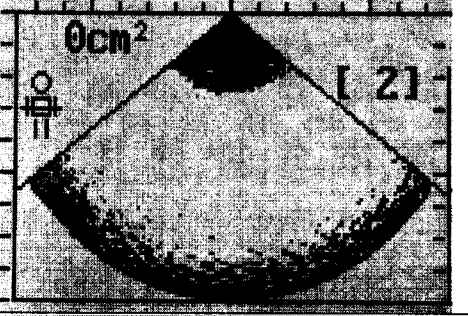
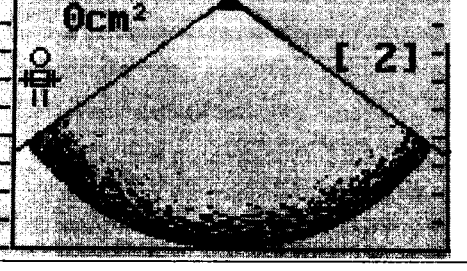
No.	Image	Description
1		In this case, the mode showing the scan result is set as CONTOUR.
2		Normal Image Scanned image from open object (in air)
		Image when the transducer connection is open. Check the resistance from the ultrasonic probe connector to the 18 <sup>th</sup> and 20 <sup>th</sup> pin

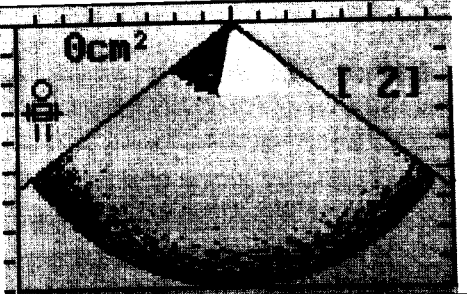
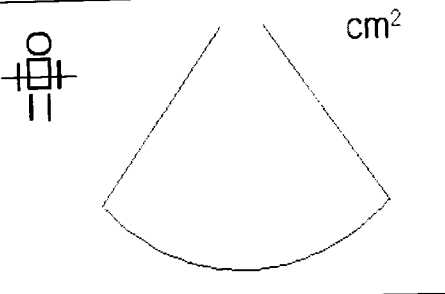
		<p>Error in transducer connection. Retry after replacing the probe</p>
3		<p>Check if 'SCAN RESULT' is set as 'CONTOUR'. Yes, retry after setting as 'B-MODE'. No, request service from the headquarter.</p>

**6.9 Error in motor rotation during scan operation**

No.	Check point	Description
1	<p>Check error in motor. Measure the resistance of each case in probe Connector</p> <ul style="list-style-type: none"> <li>1) Pin number 5 and 8</li> <li>2) Pin number 10 and 11</li> <li>3) Pin number 13 and 15</li> <li>4) Pin number 16 and 17</li> </ul>	Normal resistance value 15 +/- 1 (Ohms)
2	In case of normal resistance	Test again after replacing with other analog board

**6.10 Error in Printing (No feeding)**

No.	Check point	Description
1	Thermal Paper	No paper. Properly inserted.
2	Motor sound?	Yes, go to 3 No, check the printer connector
3	Not solved?	Replace control board.

**7. Maintenance Mode**

Maintenance mode can be used to adjust the system variables before the shipment.  
Set-up of those variables follows the procedure below.

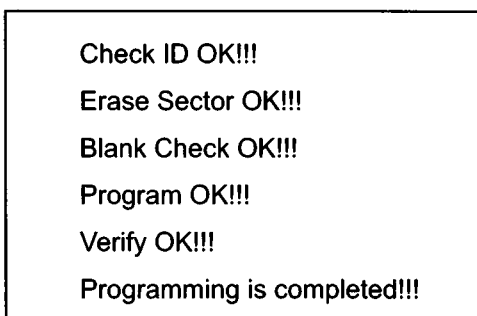
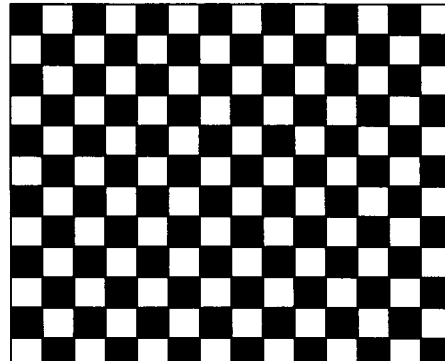
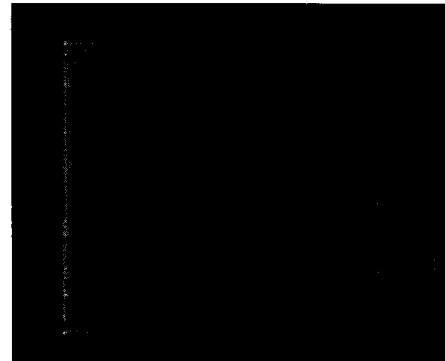
No.	LCD Screen	Manipulation
1		To enter the Maintenance mode, push LEFT key with ENTER key being pushed and then push PRINT key after the system is turned on and the initial screen is displayed in normal mode. At this time, the information as left is displayed on the screen.
2		Turn off the system and again turn it on to have the checkers as shown left on LCD.
3		When the system is booted in maintenance mode, the message "MAINTENANCE MODE" will be displayed on the lower part of the screen as left.

4	<p align="center">&lt;&lt;MAINTENANCE MODE&gt;&gt;</p> <p>Maintenance mode should be accessed by only qualified person.</p> <ol style="list-style-type: none"> <li>1. To go to 1<sup>st</sup> maintenance menu press ENTER key.</li> <li>2. To go to 2<sup>nd</sup> maintenance menu press PRINT key</li> <li>3. To return top menu press DOWN key.</li> </ol>	<p>The initial screen of the system is displayed after approximately 10 seconds of the appearance of checkers. At this time, push RIGHT key with LEFT key being pushed together to display the screen as left.</p> <p>Push ENTER key to display 1<sup>st</sup> maintenance menu, push PRINT key to display 2<sup>nd</sup> maintenance menu. DOWN key to return to the previous page.</p>																				
5	<table border="1" style="width: 100%; border-collapse: collapse;"> <tr> <td style="padding: 2px;">▶ Calibrat.(M2)</td> <td style="padding: 2px;">Return</td> </tr> <tr> <td style="padding: 2px;">Cal. Value</td> <td style="padding: 2px;">9</td> </tr> <tr> <td style="padding: 2px;">Min. Contrast</td> <td style="padding: 2px;">2</td> </tr> <tr> <td style="padding: 2px;">Max. Contrast</td> <td style="padding: 2px;">8</td> </tr> <tr> <td style="padding: 2px;">Store Mode</td> <td style="padding: 2px;">Current</td> </tr> <tr> <td style="padding: 2px;">Auto Power</td> <td style="padding: 2px;">5 minutes</td> </tr> <tr> <td style="padding: 2px;">Print Density</td> <td style="padding: 2px;">8</td> </tr> <tr> <td style="padding: 2px;">Scan Status</td> <td style="padding: 2px;">on</td> </tr> <tr> <td style="padding: 2px;">System Reset</td> <td style="padding: 2px;">Return</td> </tr> <tr> <td style="padding: 2px;">Exit</td> <td></td> </tr> </table>	▶ Calibrat.(M2)	Return	Cal. Value	9	Min. Contrast	2	Max. Contrast	8	Store Mode	Current	Auto Power	5 minutes	Print Density	8	Scan Status	on	System Reset	Return	Exit		<p>Push ENTER key from the screen 4 above to display first maintenance menu as left.</p> <p>*) Key manipulation Use up/down key to move menu items from the menu.</p> <p>▶ appears beside the current menu item. To replace the item value, push ENTER key while the ▶ is still displayed for the corresponding item. To change the item value, scroll until the desired value appears by using left/right value and push ENTER key.</p> <p>*) Refer to the table below for the details.</p>
▶ Calibrat.(M2)	Return																					
Cal. Value	9																					
Min. Contrast	2																					
Max. Contrast	8																					
Store Mode	Current																					
Auto Power	5 minutes																					
Print Density	8																					
Scan Status	on																					
System Reset	Return																					
Exit																						

6	<table border="1" style="width: 100%; border-collapse: collapse;"> <tr> <td style="padding: 2px;">▶ Probe Type</td> <td style="padding: 2px;">NF</td> </tr> <tr> <td style="padding: 2px;">Outline Mode</td> <td style="padding: 2px;">ON</td> </tr> <tr> <td style="padding: 2px;">Probe Offset</td> <td style="padding: 2px;">8</td> </tr> <tr> <td style="padding: 2px;">Exit</td> <td></td> </tr> </table>	▶ Probe Type	NF	Outline Mode	ON	Probe Offset	8	Exit		<p>Push PRINT key from the screen 4 above to display second maintenance menu as left.</p> <p>*) Key manipulation Use up/down key to move menu items from the menu.</p> <p>▶ appears beside the current menu item. To replace the item value, push ENTER key while the ▶ is still displayed for the corresponding item. To change the item value, scroll until the desired value appears by using left/right value and push ENTER key.</p> <p>*) Refer to the table below for the details.</p>
▶ Probe Type	NF									
Outline Mode	ON									
Probe Offset	8									
Exit										
7	<p>Check ID OK!!! Erase Sector OK!!! Blank Check OK!!! Program OK!!! Verify OK!!! Programming is completed!!!</p>	<p>When the set-up is done, push LEFT key with ENTER key being pushed and then push PRINT key to display the initial screen without having the checkers during rebooting. At this time, the information as left is displayed on the screen. And then turn the system off.</p>								

The system variables of Maintenance mode have the following meanings.

Item	Contents
Calibrat. (M2)	Performs calibration using bladder phantom and starts calibration by pushing ENTER key with the item value set at start. Upon the end of Calibration, the result is displayed in the screen.
Min. Contrast	Controls the minimum value of contrast control when the image is displayed. The adjustable scope ranges between 2 and Max. Contrast.
Max. Contrast	Controls the maximum value of contrast control when the scanned image is displayed. The adjustable scope ranges between Min. Contrast and 8.
Store Mode	Appoints which one to store from the current session. In case of current, the last scanned value is stored. And in case of maximum, the image data with maximum volume is stored. Inapplicable at present but an upgrade is scheduled in the near future.
Auto Power	Sets up the time until the system is turned off when no key is entered. The system is not turned off even if there is no key input when the system is set Off.
Print Density	Adjusts the density of the print out. The adjustable value ranges from 3 to 10.
Scan Status	On/off control scan status information which shows how much current scan is centered.
Exit	Returns to the previous screen in Maintenance menu.
Cal. Value	Change the threshold value. Value range is from 5 to 20. This value is changed during calibration process.
System Reset	Reset values of system variables to default.
Probe Type	NF / Non-NF To be set according to the probe version. When probe is changed, this value is confirmed according to probe version.
Outline Mode	On / Off control To control whether the edge information of the bladder is displayed or not on the screen with ultrasound image. On : The edge information will be displayed.
Probe Offset	Set the initial position of the transducer in the probe. Range is from 3 to

	12. This value is set during calibration process.
--	--

## 8. Circuit Diagram 8.1 Analog Board

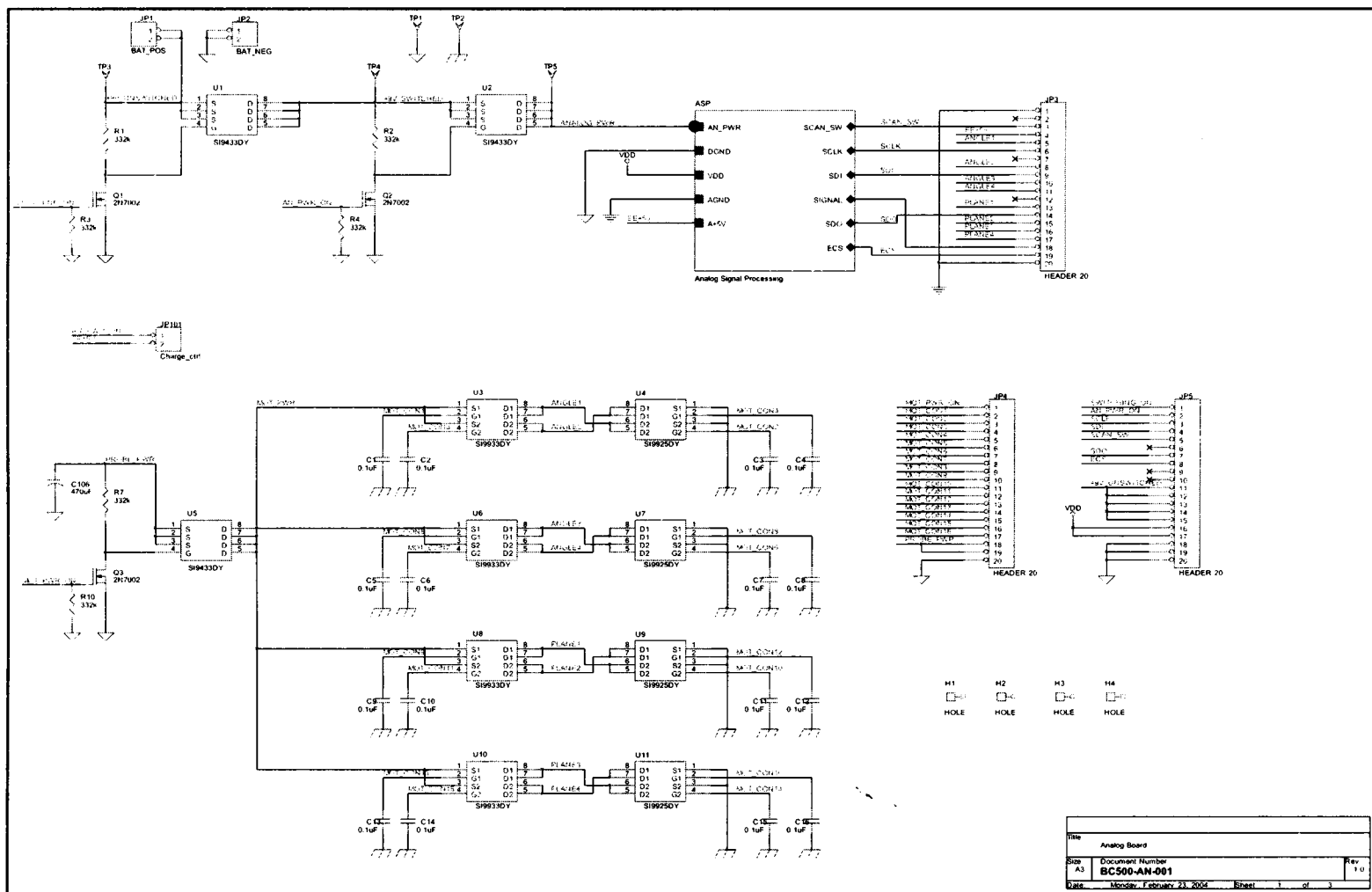
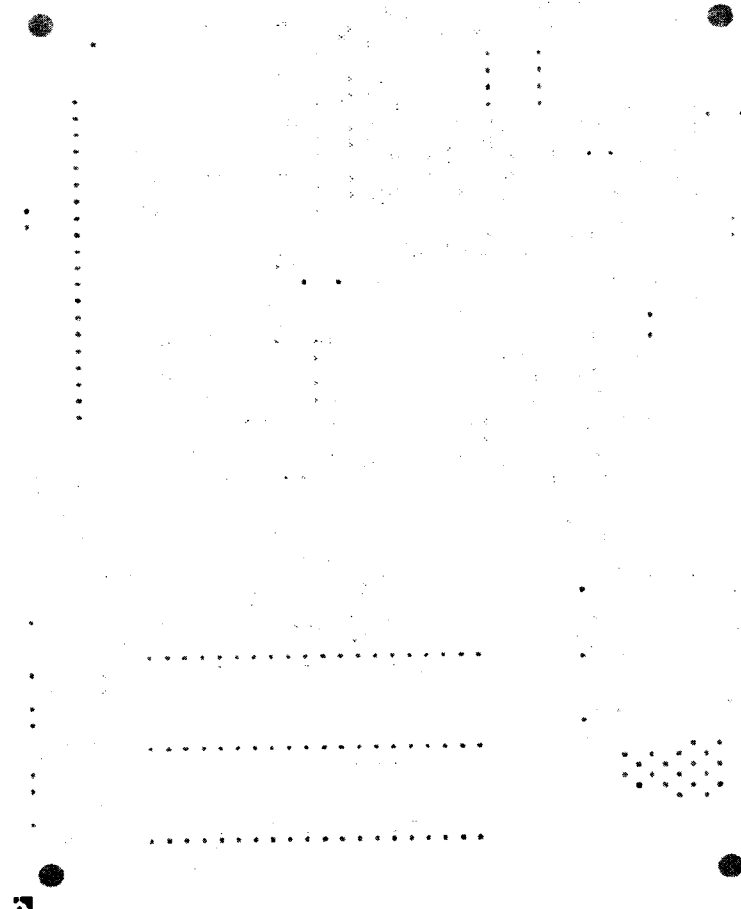

Title	Analog Board	Rev	1.0
Doc. No.	AS BC500-AN-001		
Date	Monday, February 23, 2004	Sheet	1 of 3

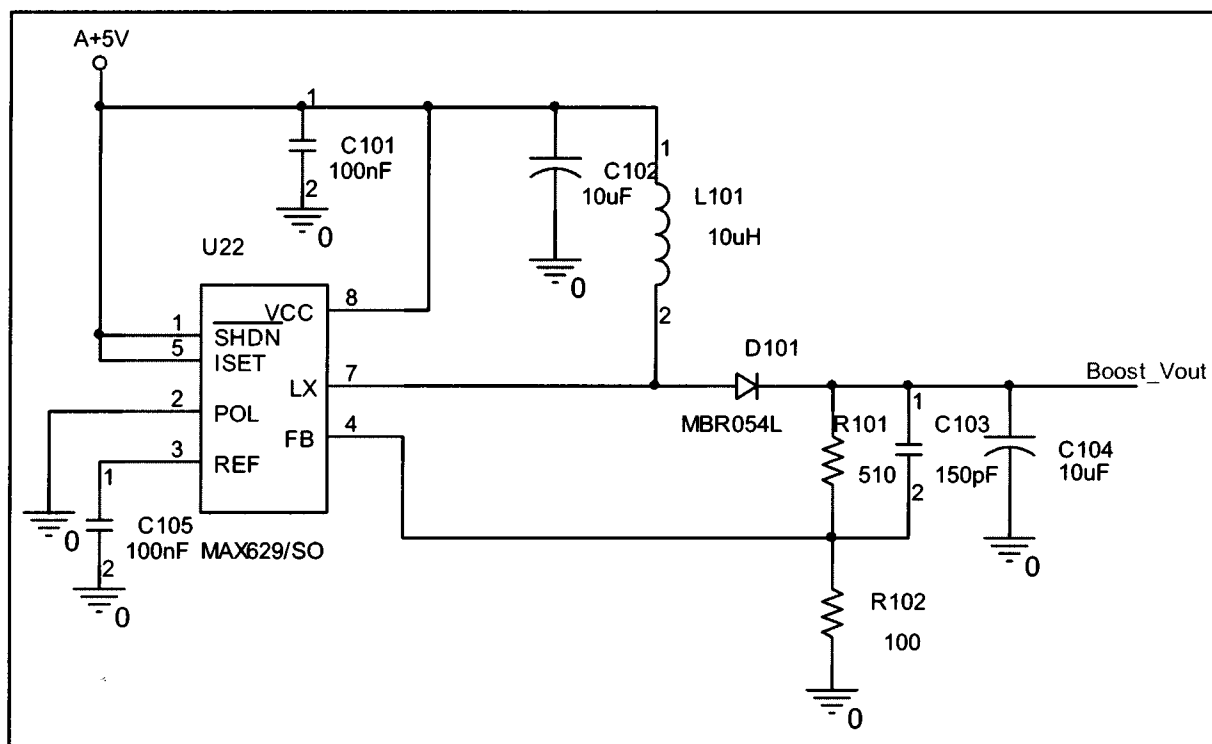
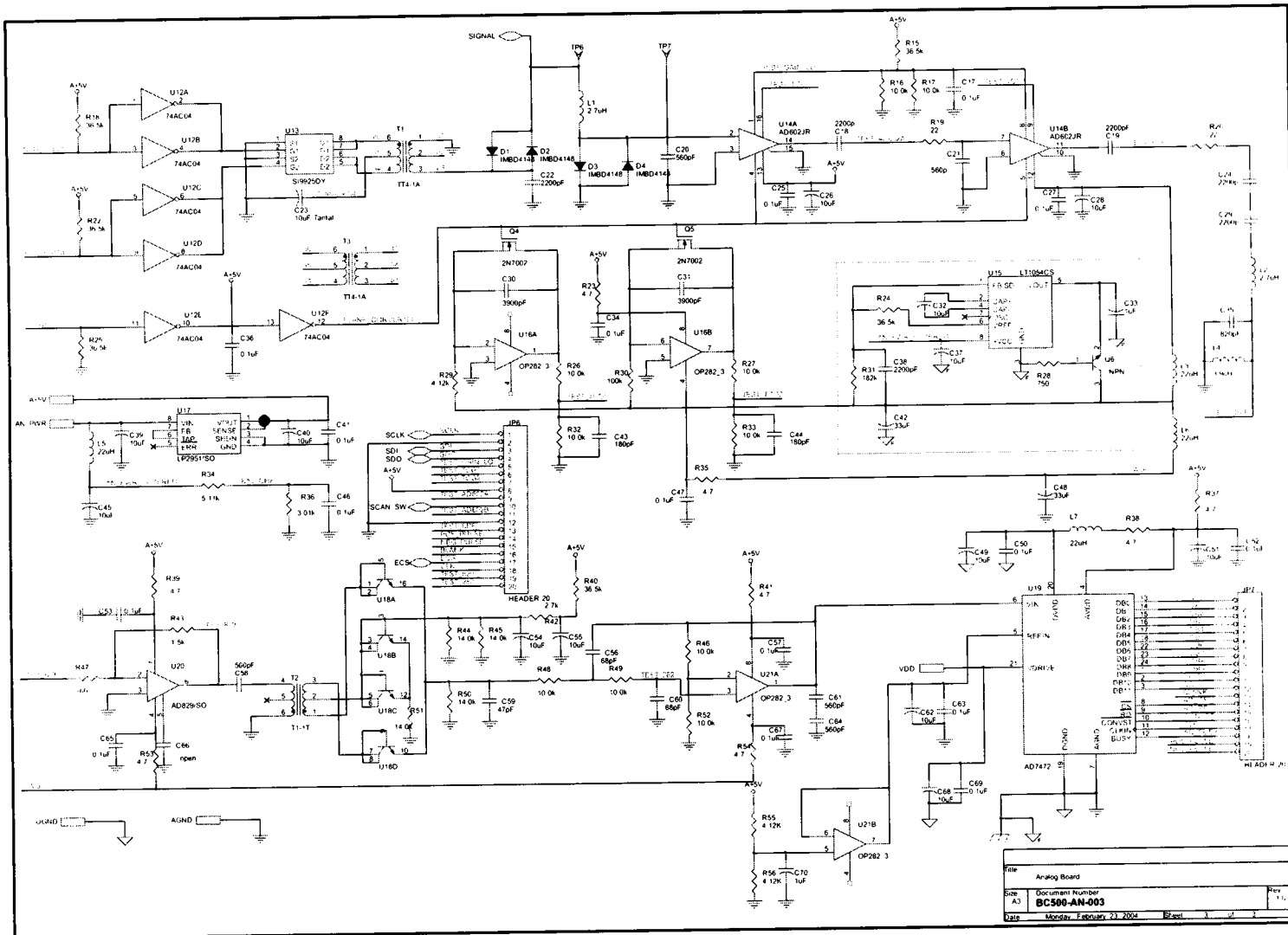

8.2 Control Board

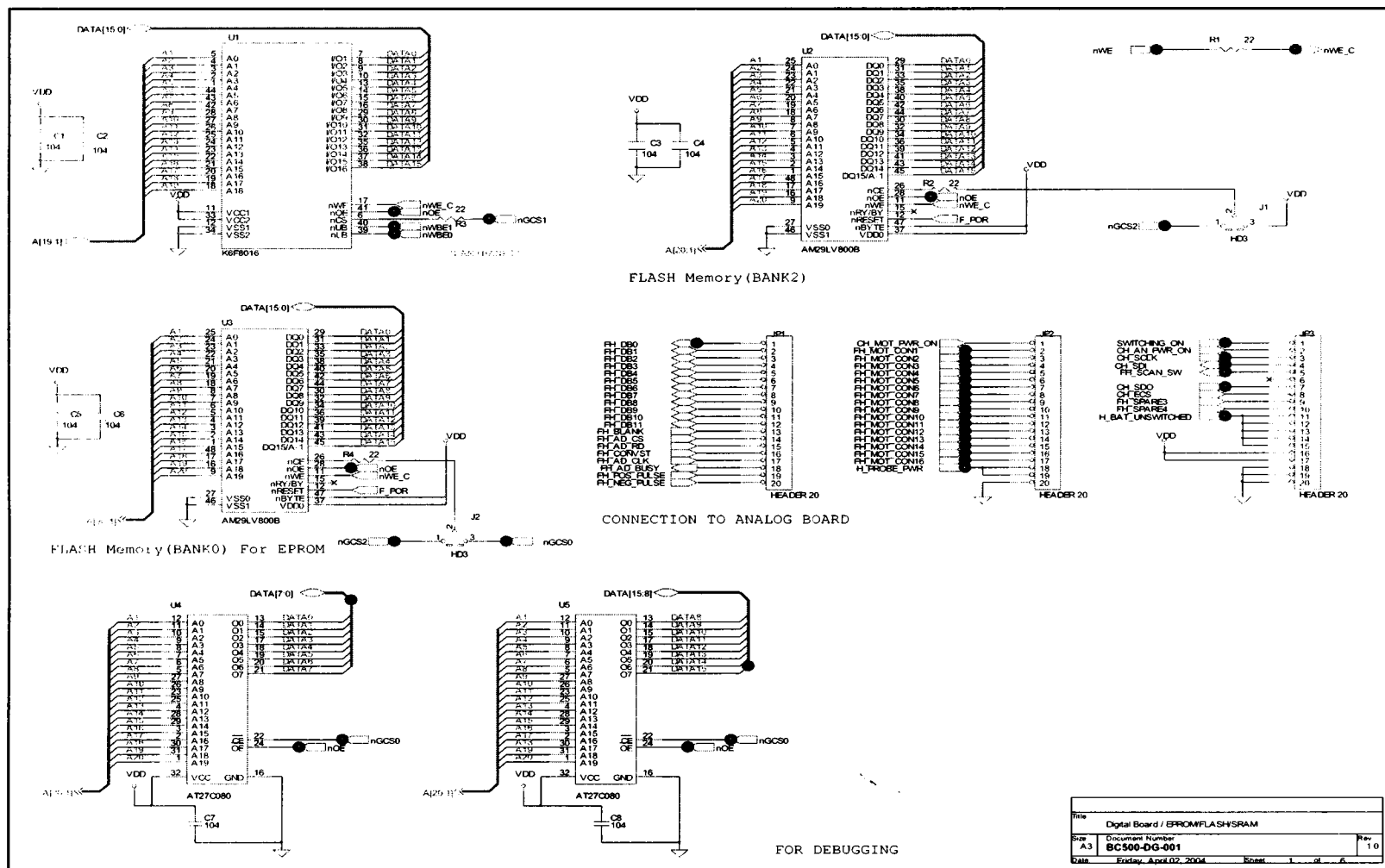

Title	Digital Board / EPROMFLASH+SRAM
Doc. Number	BC500-DG-001
Rev	1.0
Date	Friday, April 02, 2004
Sheet	1 of 1

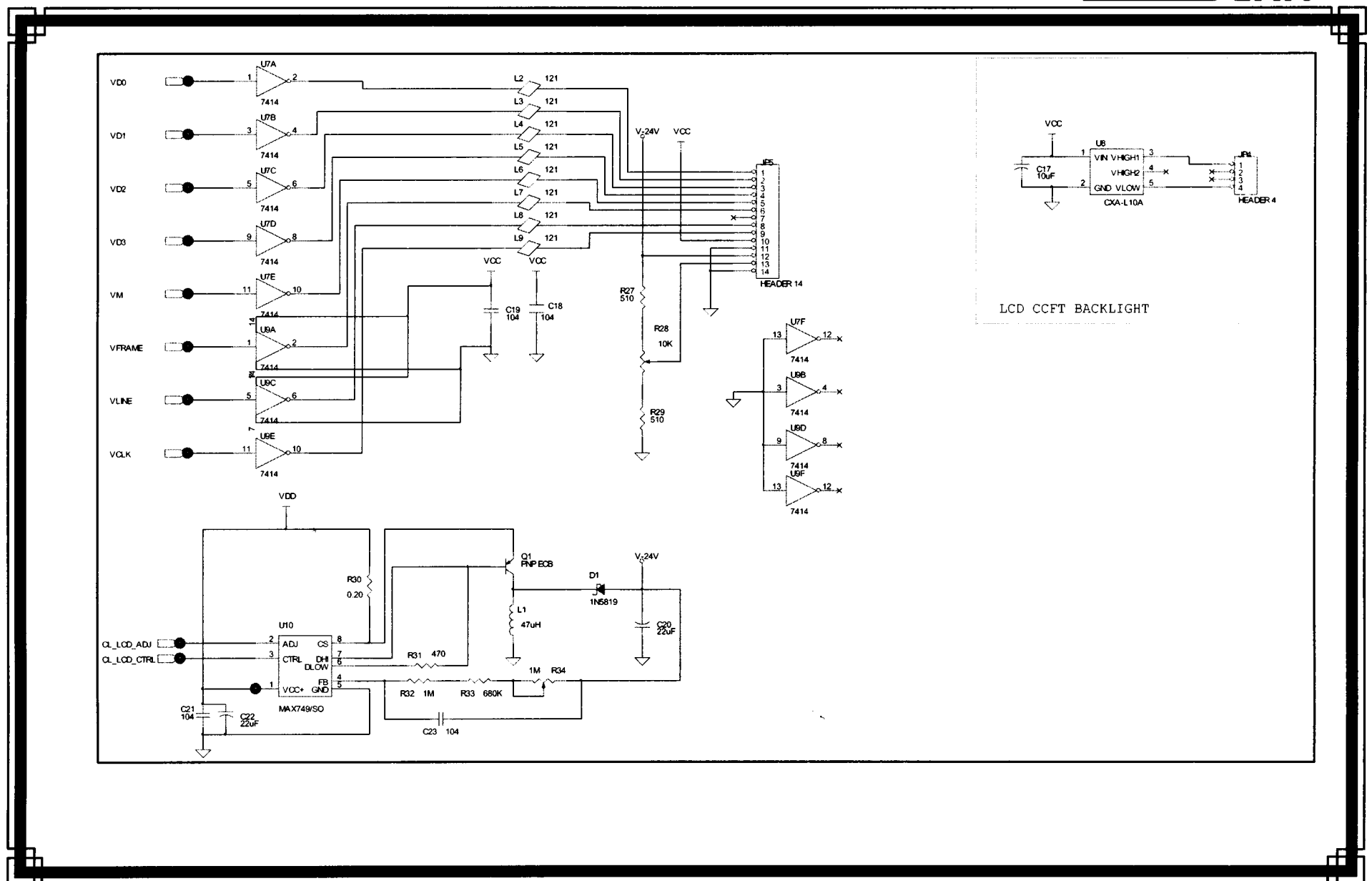
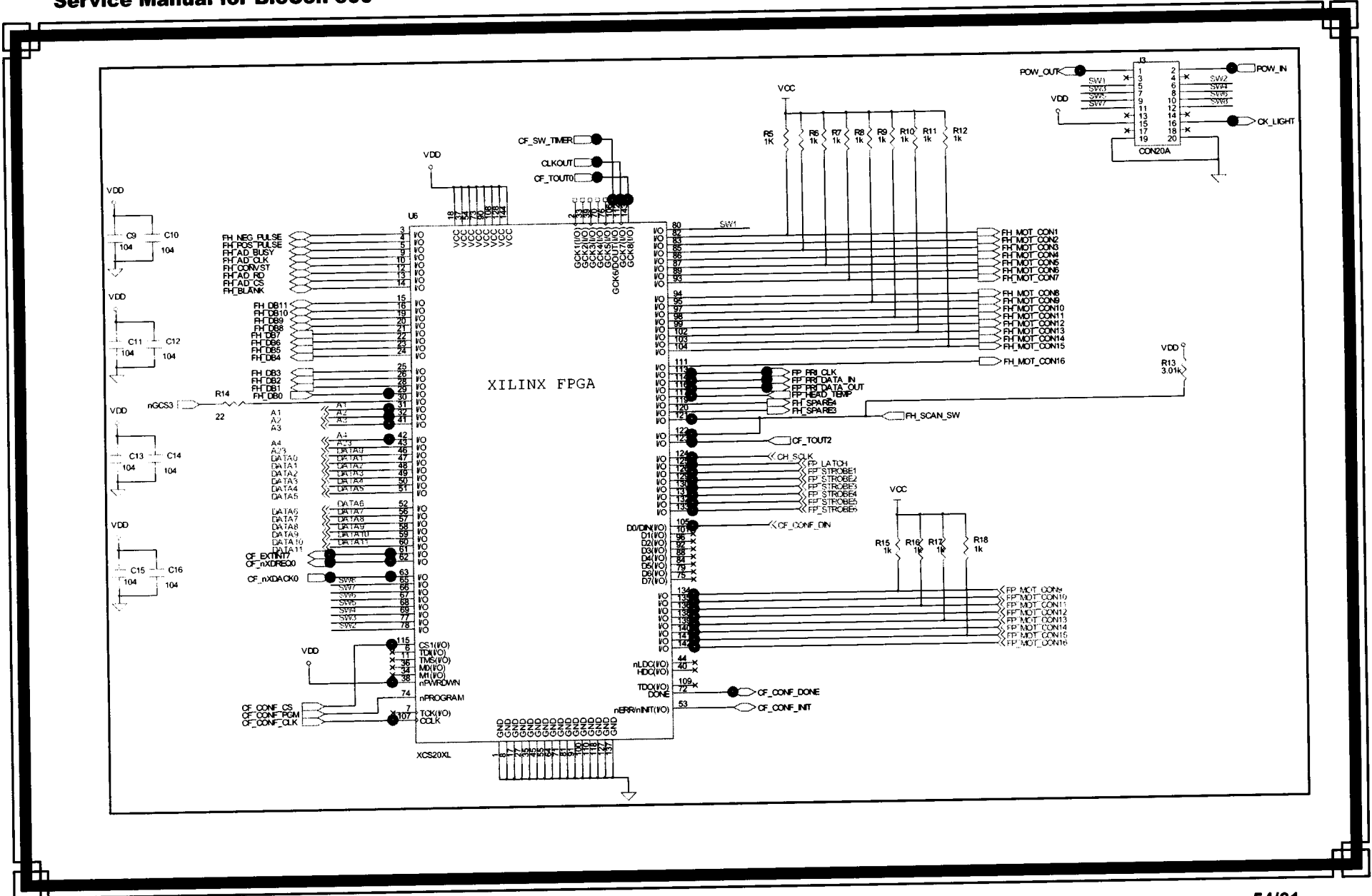



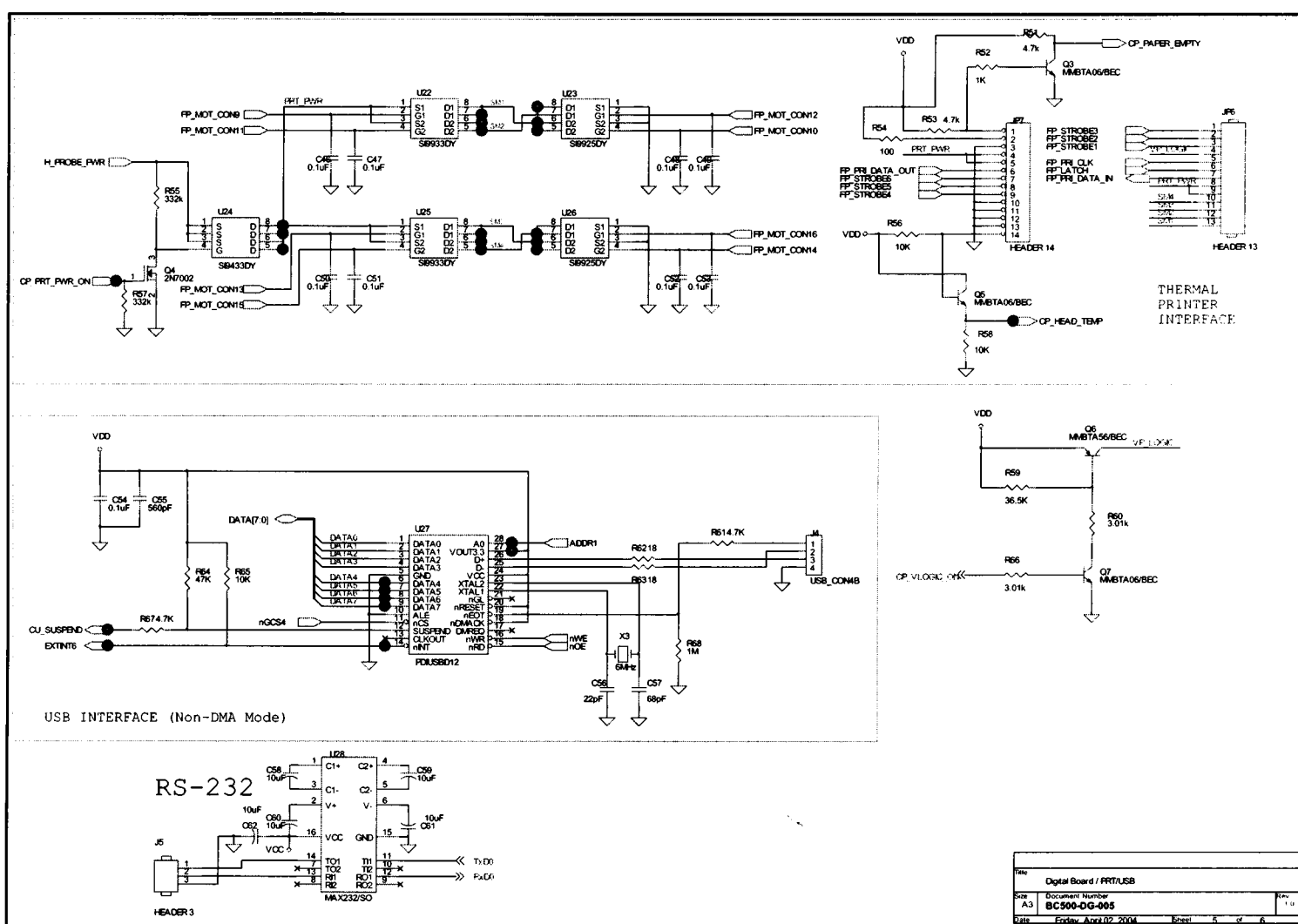
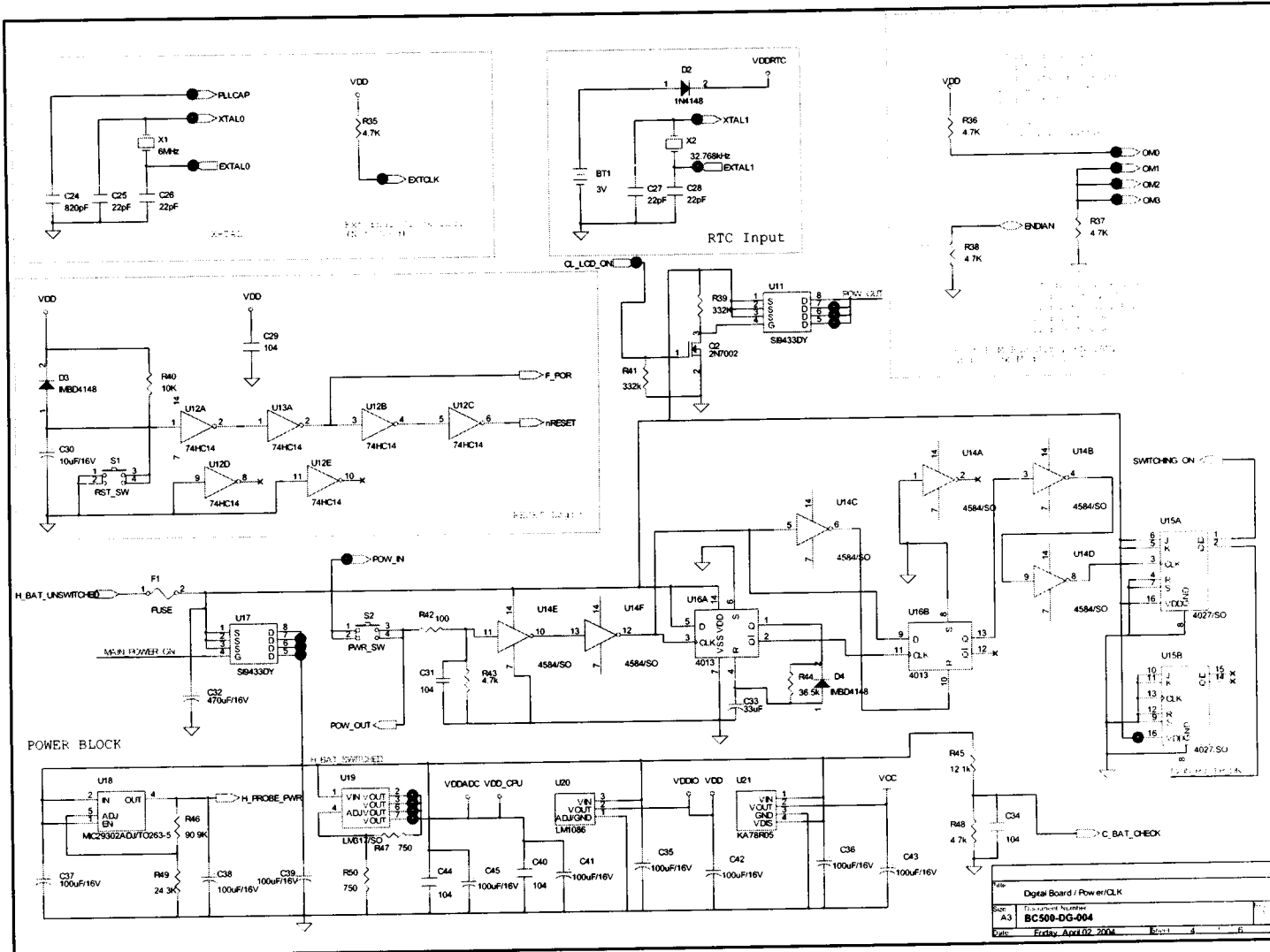

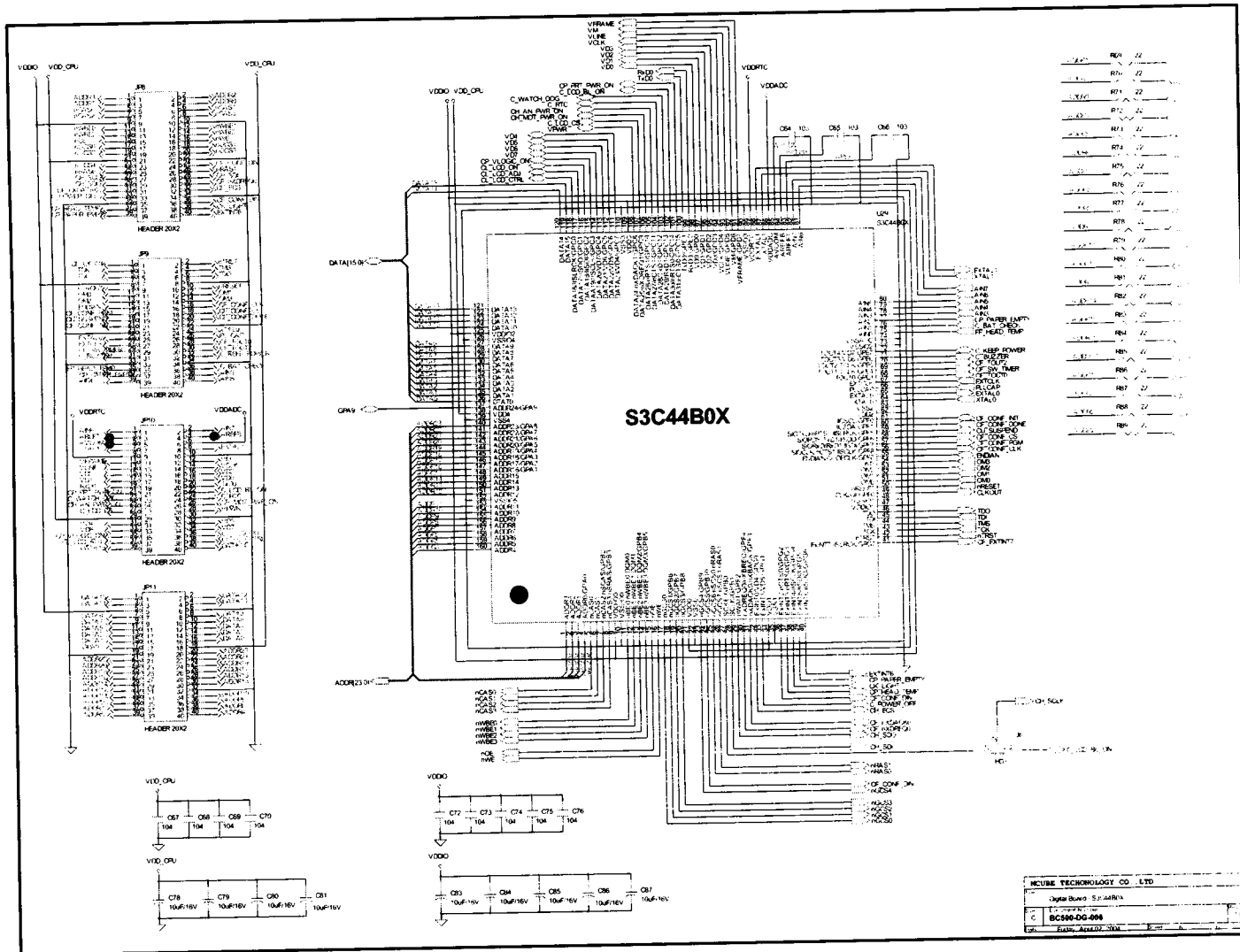

8.3 Charging Board

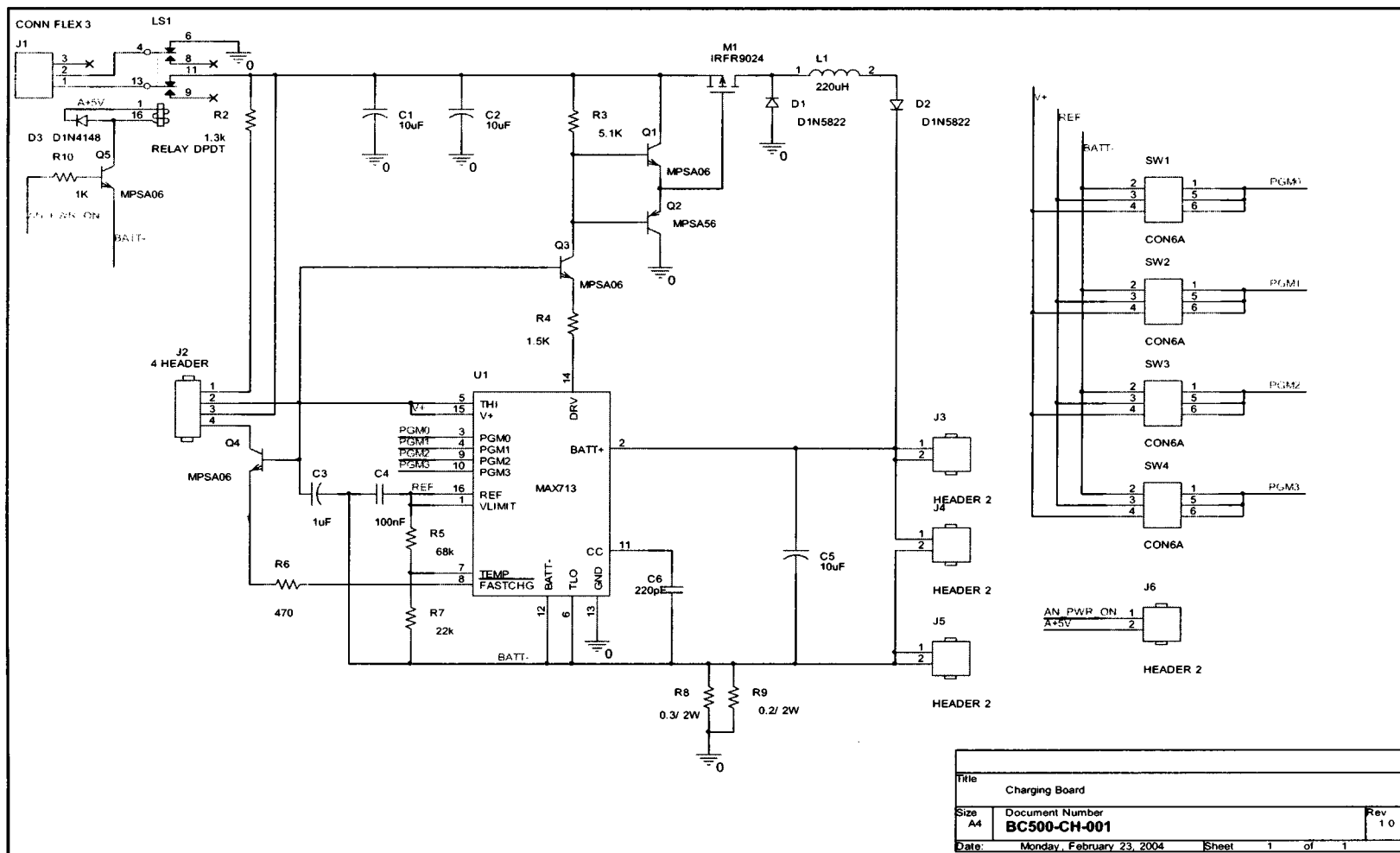

8.4 Connection Board

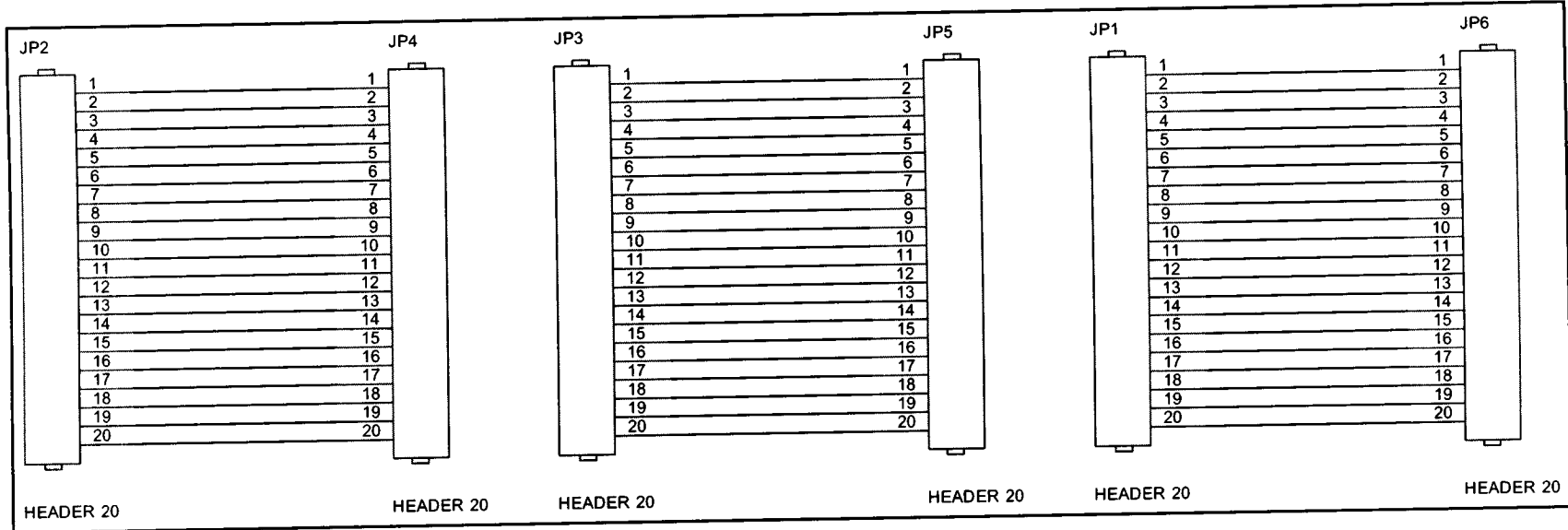

8.5 Key Board

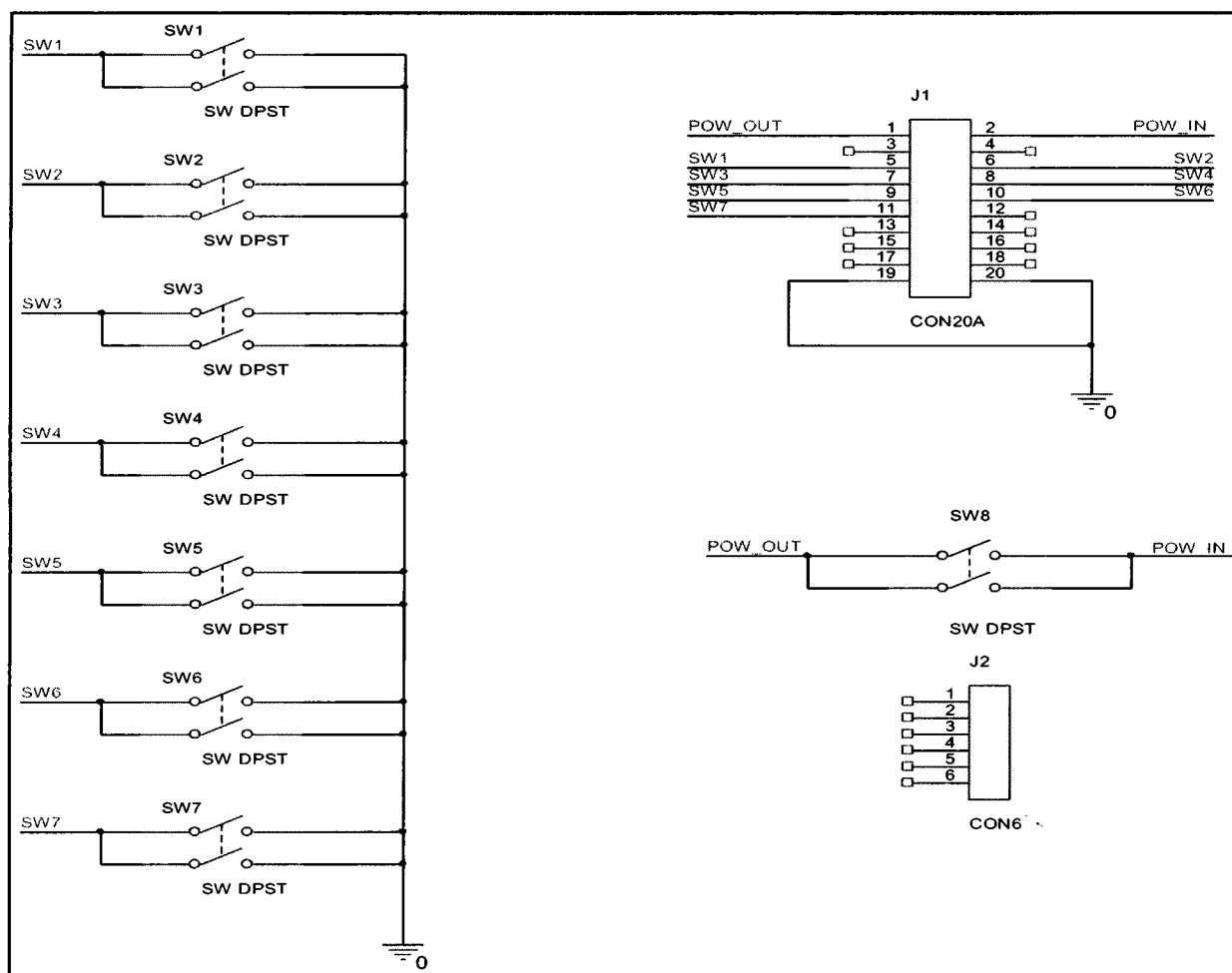

# **CUBESCAN**

BioCon-500™

Bladder Volume Measurement System



---

## **Mcube Technology Co., Ltd. Representative**

#803 Shinnae-Technotown  
485 Sangbong-dong Chungnang-gu  
Seoul, 131-220, KOREA  
Phone: +82 2 3421 7780  
Fax: +82 2 3421 7076  
E-mail: [mcube@mcubetech.co.kr](mailto:mcube@mcubetech.co.kr)  
[www.mcubetech.co.kr](http://www.mcubetech.co.kr)

**MUM-BioCon 500(Rev. 1.21)**