



Cod.4073



Operation and maintenance manual

STEAM AUTOCLAVE

MODEL

STERILX BABY



Thanks you for having bought one of its products and asks you to read this manual.

The manual contains all the information you require in order to use the machine you have purchased. Please carefully comply with the instructions given in the manual and carefully read all its parts. Keep the manual in a suitable place so that it remains in a perfect condition.

Following improvements or variations to the appliances, the contents of this manual may be liable to modification without prior notice or other obligations.

This manual contains an installation form which must be fully filled out by the technician when he installs the machine.

This form will be considered the reference certificate that validates the warranty. It must be sent back to us along with the printer coupon and warranty form.

Duplication or translation of any part of this manual is forbidden unless prior written authorization has been obtained from the Manufacturer.

Table of contents:



1. INTRODUCTION	3
2. TECHNICAL SPECIFICATIONS	4
3. GENERAL RECOMMENDATIONS	6
3.1 Regulations for the operator.....	6
4. LOCATION OF THE CONTROLS	7
5. STARTING AND SETTING AT WORK	9
5.2 Installation and preliminary inspections.....	10
6. GENERAL INSTRUCTIONS FOR USE	11
6.1 Method of use.....	11
6.2 End of work.....	11
7. HOW TO ARRANGE THE INSTRUMENTS FOR THE STERILIZING PROCESS	12
7.1 Standard sterilizing.....	12
7.2 Sterilizing handpieces.....	12
7.3 Messaggi visualizzati dal display.....	12
8. STERILIZING CYCLES	13
8.3 Sterilizing table.....	13
8.2 Notes and warnings.....	14
9. FAULTS	15
9.1 Troubleshooting: Solutions / Remedies.....	15

1. INTRODUCTION

The machine described in this operation and maintenance manual is a steam sterilizer that has been specially designed to sterilize most of the materials and instruments used in dental surgeries, doctors' surgeries and hospitals in general.

The machine can either operate at a temperature of 134°C and a pressure of 2.1 Bar or 121°C and a pressure of 1.1 Bar. These parameters are monitored and kept at constant levels by three mechanical and electronic devices that ensure an optimal sterilizing process along with total safety.

The operating cycles can be monitored by means of the pressure gauge, warning lights and by the position of the controls.

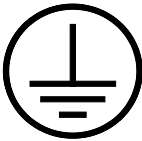
SYMBOLS AFFIXED TO THE MACHINE		WARNING: IDENTIFIES A HEAT SOURCE. A PART COULD BE DANGEROUSLY HOT
		WARNING: IDENTIFIES A GENERIC DANGER. THERE COULD BE A POTENTIALLY DANGEROUS CONDITION
		IDENTIFIES THE GROUND CONDUCTOR

Do not use the machine for purposes other than those for which it has been built.



To prevent the autoclave from being subjected to electrical disturbance, it is important to make sure that the earth resistance value is sufficient and well coordinated with the protections in your electrical system.



- **This symbol it means the product is covered by the European Directive 2002/96/EC.**
- **Please inform yourself about the local separate collection system for electrical products.**
- **Please act according to your local rules and do not dispose of your old products with your normal household waste. The correct disposal of your old product will help prevent potential negative consequences for the environment and human health.**

2. TECHNICAL SPECIFICATIONS

This autoclave has been designed and built in compliance with the operators' need for functionality, practical use and safety.

This autoclave has functional characteristics that make it unique, i.e.:

- Main switch to power the machine.
- 60 minute cycle program.
- Five minute final drying phase.
- Switch to select the 121° or 134° cycle.
- Fully visible water filling from the top.
- Built in drying cycle with evaporation system.
- Continuous venting of the air in the chamber to encourage the maximum steam saturation.
- Approved safety valves to prevent over-pressures.
- Safety valve to protect the heating element.
- Safety thermostat to monitor the drying operation.
- 121° - 134° operating pressure switches.
- Chamber in seamless press-moulded 18/10 STAINLESS STEEL.
- 7 liter chamber capacity able to hold up to 3 trays.
- Condensation radiator to drain off the water at the end of the cycle.
- Used water can
- Filling with the 250 cc dispenser.

Description	Unit of measurement	Values
--------------------	----------------------------	---------------

Power source voltage rating	V	Alternata 230 ~
Power source frequency	Hz	50/60
Machine power rating	W	1000
Boiler volume	mm	Ø 170 x 270
Operating pressure	Bar	2.1 - 1.1
Machine dimensions X, Y, Z	mm	390 x 370 x 300
Gross weight	Kg	20
Pack dimensions	mm	470 x 450 x 380
Operating temperatures	°C	+ 3°C + 35°C
Distance from walls	mm	20

X = depth

Y = width

Z = height



The electrical system is protected against the risk of over-currents by two 10 A 6,3x32 delayed action fuses (T 10 A) installed inside the machine.

Only have these fuses changed by a skilled electrician.

The machines have been designed to operate up to an altitude of 1200 mm above sea level. Contact the manufacturer if the machine must operate at a higher altitude as special models and/or devices may be required.

The noise level of the machine has been tested. The continuous equivalent weighted acoustic pressure level A is less than 70 dB (A) and the continuous equivalent weighted acoustic power level A does not exceed 85 dB (A). The measured noise level measured is therefore very low. For this reason, the operator need not take any particular measures (also in view of the fact that the machine operates automatically).

DATA AND SPECIFICATIONS OF THE PRESSURIZED VESSEL:

Serial N° of vessel, Serial N° of door	Month N°, Year N° (see internal label)
Max. operating pressure:	2,2 Bar.
Max. operating temperature:	160°C
Min. operating pressure:	-0,9 Bar.
Test pressure:	8 Bar.
Reference standards:	TRD 421
Volume of vessel:	7 lt.

3. GENERAL RECOMMENDATIONS

3.1 Regulations for the operator

- Always wear personal protective equipment in compliance with the directives that establish the current accident-preventing provisions.
- Do not approach the machine with inflammable materials.
- Do not carry out repairs or maintenance work whilst the machine is operating or plugged into the electricity main or when parts of it are hot.
- Only responsible adults may use the machine in places inaccessible to children.
- Use the machine in a dry place, sheltered from the rain.
- Periodically inspect the power cable to make sure that it is in a good condition.
- If there are several persons in the place of work, remember to keep at a safe distance from the machine to prevent accidental contact with hot parts.
- Never ever operate the appliance unless the power cable is in a perfect condition and the structure undamaged.
- It is advisable to keep the door half-open when the appliance is not in use.
- Do not move the machine when the tank is full of water.



Pay the utmost attention to those parts of the appliance that become hot during operation and that still remain hot after it has been switched off. Keep your face well away from the top part of the machine when the door is opened to prevent it from being scalded by steam. Keep about 50 cm. away from the machine when opening the door.

As specified in the technical specifications, these autoclaves operate at a pressure that can reach 2.2 Bar at most. Do not use the autoclave in an improper way and do not carry out maintenance operations while the sterilizing cycles are in progress. Remember that the pressure is shown by the pressure gauge installed on the front of the machine itself.

Wait at least 20 minutes after the appliance has been switched off, to allow the boiler to completely cool.

4. LOCATION OF THE CONTROLS

Autoclave features an elegant casing treated with scratch-proof epoxy powder paint in the **RAL 7035 COLOUR**. No particular preparations are required to operate the machines. Just fit the plug into a 230 V power socket. The power draw of the machines is **1500 Watt**. The control panel is elegantly designed, easy to read and consists of (see page 9):

- 1 - **WARNING LIGHT TO INDICATE DRYING CYCLE IN PROGRESS**
- 2 - **134°C CYCLE INDICATOR LIGHT**
- 3 - **121°C CYCLE INDICATOR LIGHT**
- 4 - **DISPLAY**
- 5 - **CYCLE PROGRAMMER TIMER**
- 6 - **PRESSURE GAUGE**
- 7 - **MAIN SWITCH**
- 8 - **CYCLE START/STOP**
- 9 - **CHAMBER**
- 10 - **DOOR OPENING DEVICE**
- 11 - **RESET HEAT**

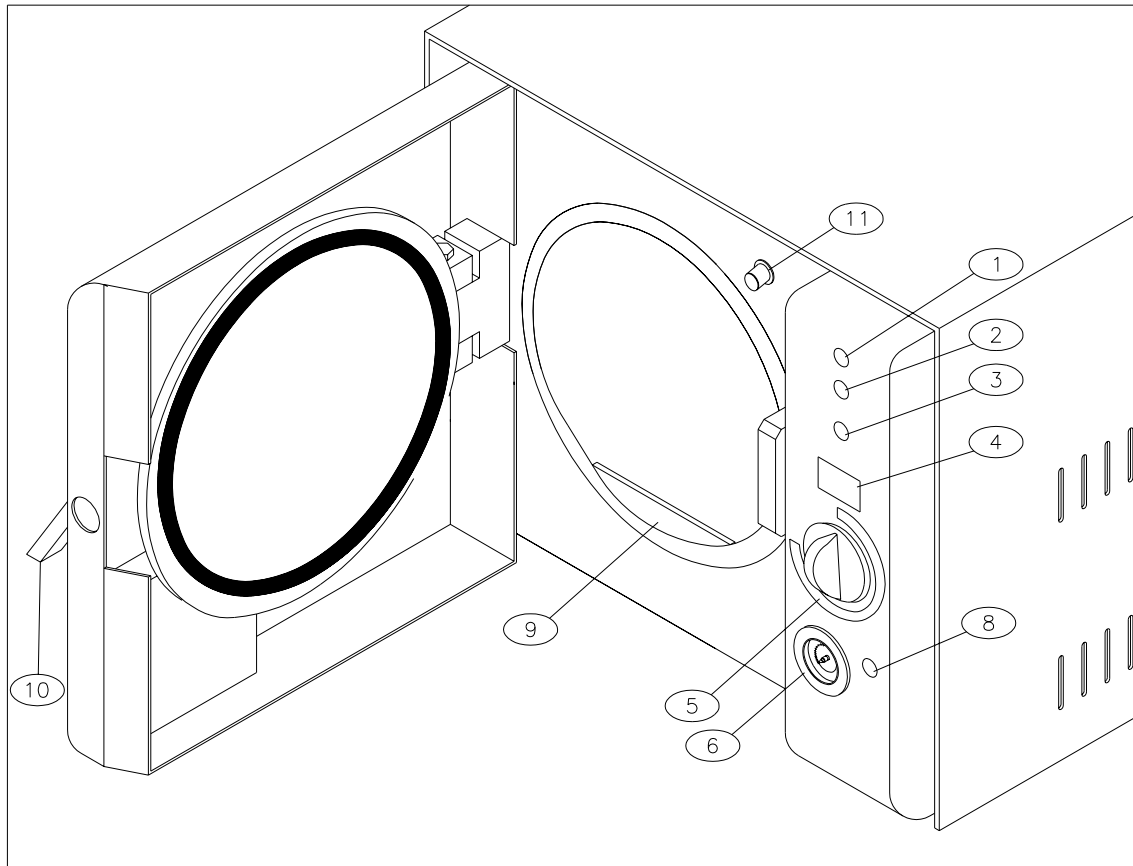

THE FOLLOWING ACCESSORIES ARE SUPPLIED:

1 TRAY HOLDER, 2 TRAYS, 1 TOOL TO TAKE OUT THE TRAYS AND ADJUST THE DOOR, 1 SPONGE, 1 INSTRUCTION MANUAL, 1 10 LITER CAN, 1 250 CC DISPENSER.

DESCRIPTION OF THE REAR PART

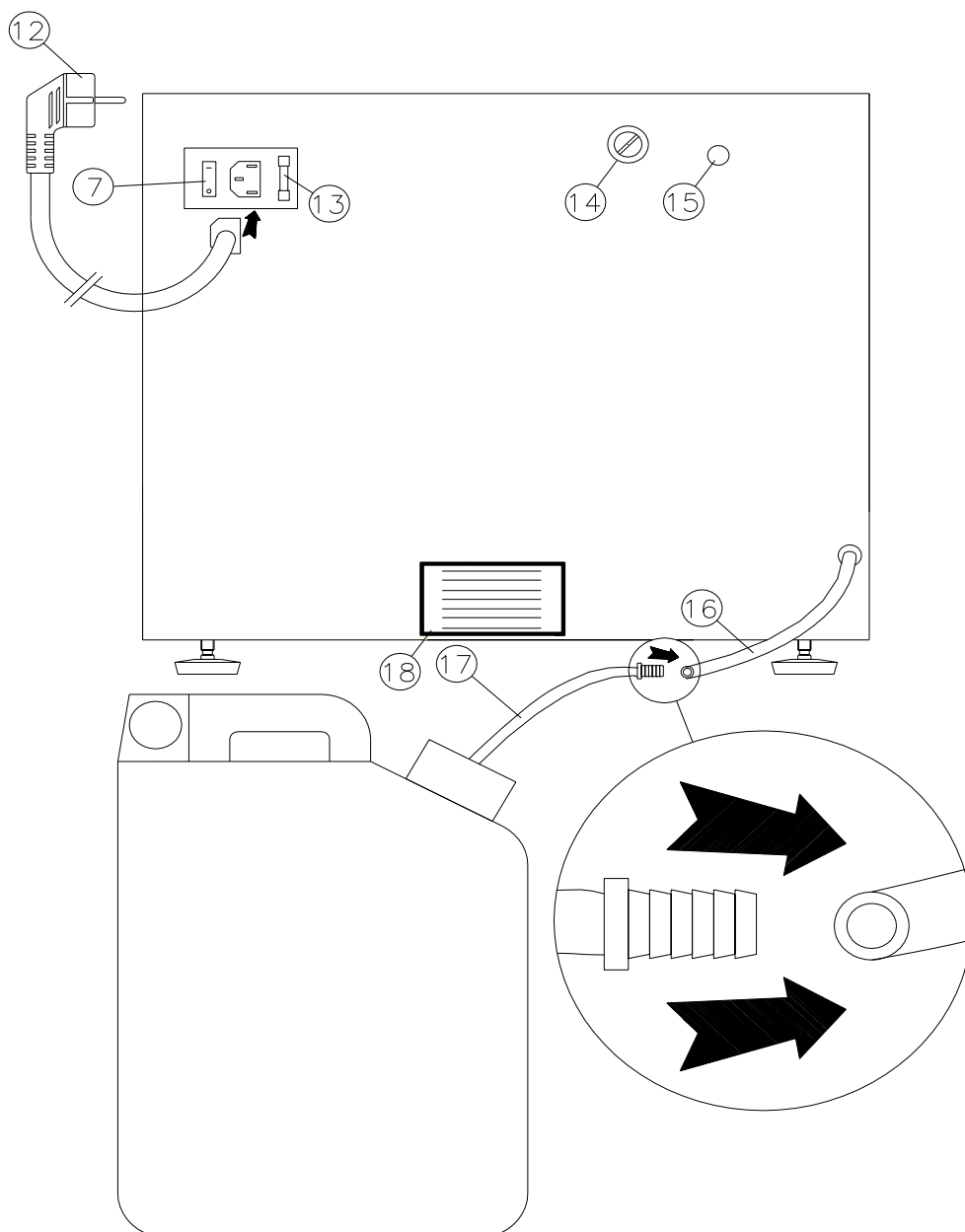

12) Power cable with Shuko France plug.

13) Fuse T10A 5x20.

14) Regulation thermostat.

15) Safety valve **discharge**.

16) Used water drain tube to connect to the can by means of tube "17"

17) Can tube to connect to the used water drain tube "16".

18) Label with the following data: Model, CE marking, power supply voltage and frequency ratings, power draw, serial number, year of manufacture, manufacturer's generalities.

5. STARTING AND SETTING AT WORK

5.1 Removing the machine from the packing

The machine is consigned packed on a wooden pallet out a cardboard box: make sure that there are no dents and that the wrapping is in optimum conditions.

The machine must be stored in a dry place, sheltered from adverse weather conditions, at a temperature between +3°C and +35°C.

The machine must be handled without jolting and using appropriate means.

Open the pack without overturning it.

Remove the polystyrene from the top and sides (the weight of the model is given in chap. 2, technical specifications).

Remove the pluriball wrapping from around the machine and make sure that all parts of this latter are undamaged and complete with all the accessories indicated on the consignment note. Immediately notify our dealer if discrepancies are discovered.

Keep the packing materials for as long as the machine remains in use, not just for the warranty period. This is because the autoclave may need to be calibrated or regulated by the manufacturer's staff or by an after-sales center. Non-original packing is unable to ensure that the machine is correctly protected during transport.

The original packing comprises the following items:

- BIWALL BOX IN CARDBOARD WITH 3 CORRUGATIONS
- PLURIBALL POLYETHYLENE BAG
- SHAPED POLYSTYRENE FOAM
- PALLET OUTSIDE THE BOX

5.2 Installation and preliminary inspections



The installer is obliged to make sure that the place in which the sterilizer is installed is fit for that purpose (CEI 62/4).

The machine is sent packed on a wooden pallet. Make sure that the packing has not been damaged and that everything is in a perfect condition. Handle the box by means of its handles and place it on a surface in the immediate vicinity of the place in which the machine is to be positioned (the weight of the model is given in chap. 2, in the technical specifications).

Remove the machine from its wrapping by pulling it out of the box vertically, using 2 hooks (available on the market) inserted into the two holes at the sides of the casing. Remove the polystyrene filler balls from around the machine. Make sure that none of the parts has been damaged and that the machine is complete with all the accessories indicated in the consignment note. Immediately contact our reseller if discrepancies are discovered.

All the packing materials must be kept for guarantee purposes. Machines returned without their original packing will not be accepted.

Install the autoclave in a well ventilated place, well away from sinks, heat sources, grinders and from all other machines that create vibrations and/or dust.

Place the autoclave delicately on to a perfectly flat surface. Take care to leave a space of about 5-10 cm all around the machine to allow for aeration.

Autoclave must be installed in a well lighted place equipped with an electrical system that complies with the current standards in force.

Remember that cannot be built into other furniture as it is filled with water from the top.

Fit the electric plug into a socket **WITH A CAPACITY OF AT LEAST 10 Ampere AND EQUIPPED WITH AN EARTH CONNECTION**. Make sure that the mains voltage rating corresponds to the value indicated on the label at the rear of the machine (230 Volts).

Must only be filled with DISTILLED WATER to ensure that the electrical and air-operated devices operate efficiently and are long lasting.

Carry out a cycle of dry-run tests using one indicator (type TERMALOG or VAPOR LINE EXTENDER).

Keep the receipt which should be attached to the installation form and sent off along with the warranty.

Never connect the plug of the machine to a reduction.



Do not install the machine in places at altitudes of more than 1200 m. above sea level.

If this is the case, contact the manufacturer for a special version of the machine.

Use a bubble level to make sure that the surface on which the appliance is to be positioned is perfectly horizontal.

Fill out and send off the warranty form.

6. GENERAL INSTRUCTIONS FOR USE

6.1 Method of use

- a) Open the door by means of the device (10).
- b) Turn on the main switch (7).
- c) Arrange the instruments on the supplied Trays without overlapping the packets. The maximum load allowed is 1 kg.
- d) Fill the chamber with distilled water using the supplied dispenser, which holds 250 cc when full.
- e) Shut the door using the handle (10).
- f) Select the required sterilizing time using the timer (5). This time can vary depending on the load of instruments and the type of material.
- g) Activate the selected sterilizing cycle with keys (2) or (3).
- h) If very delicate materials are sterilized, it is advisable to remove them as soon as the cycle ends or even during the dry phase (1), after making sure that the pressure gauge (6) setting is Ø.
- i) Each time that a cycle is carried out, place an indicator (the TERMALOG or VAPOR LINE EXTENDER) in the sterilizing chamber to confirm the sterilizing process.
- j) When the display (4) reaches Ø, sterilizing will have terminated. The door can then be opened with caution, always after having made sure that the pressure gauge (6) is on the Ø setting.
- k) The machine switches off automatically at the end of the cycle and issues an acoustic signal.
- l) If the instruments are still wet after sterilizing, proceed as follows to complete the drying process.
 - leave the door ajar.
 - select the Dry cycle (1).
 - set the required number of minutes for the drying phase with the (5).
 - now repeat the drying cycle, which will stop automatically.
- m) Use the supplied tool and wear protective gloves when removing the material from the chamber.
- n) Keep about 50 cm away from the appliance when the door is opened as residue steam could escape from the upper side of the door and could scald the operator.
- o) Open the door with care, using the device (10) and an upward movement, always after checking that the pressure gauge (6) setting is Ø. If no resistance is opposed, the door will open easily when the device (10) is moved from the right towards the left.
- p) If the door is not opened immediately after the sterilizing cycle ends, condensed watery vapour could form on its surface and drip off on opening.

6.2 End of work

After the operations have terminated, set the green main switch (10) to position 0, open the door and leave it ajar with handle (10) in the vertical position..



Pay particular attention to the temperature of the various components when you switch off the machine.

Wait a few minutes to allow the components to cool.

7.HOW TO ARRANGE THE INSTRUMENTS FOR THE STERILIZING PROCESS

7.1 Standard sterilizing

Before being sterilized, the instruments must be cleaned to remove blood residues, incrustations, foreign bodies, etc. These impurities can damage the items being sterilized, the autoclave components and prevent the sterilizing process from being correctly carried out.

These instruments must be made of NON-ferrous material since they could damage the other instruments or the autoclave itself.

To achieve perfect sterilizing, it is therefore important to proceed in the following way:

1. Rinse and brush the instruments under running water immediately after use to remove all deposits.
2. Place the instruments in the ultrasound machine with distilled water and detergent solution if possible.
3. Thoroughly rinse the instruments in demineralized water to prevent scaling stains.
4. Dry the instruments to eliminate all water residues which could lead to oxidation.
5. Wash, rinse and dry the supplied trays and make sure that they are perfectly clean.
6. To ensure that packaged instruments are perfectly dried, we recommend use of support art. M9050 supplied as an optional.
7. If loose instruments must be sterilized, it is advisable to cover the trays with a paper or fabric napkin to prevent direct contact with the tray surface: do not place the instruments straight on to the trays.
8. Scissors and forceps should be slightly opened. Mirrors and containers should be placed upside down for the sterilizing process.
9. It is advisable to keep the instruments separated from each other to achieve a better sterilizing action. Overloading will impair the sterilizing process.
10. If packaged instruments must be sterilized on the trays, place the packets with their transparent side downwards and do not overlap. The packets should not be too large. Drying will be difficult if their edges overlap.
11. The machine can operate with a maximum 3 Kg load.

7.2 Sterilizing handpieces

1. Carefully read the handpiece operation manual with particular attention to the part about sterilizing.
2. Wrap the handpiece in the special sterilizing cloth.
3. Place the wrapped handpiece on a NON-perforated tray to prevent spilt lubricating oil from polluting the pipes of the autoclave.
4. Proceed with a short cycle 121°C sterilizing program.
5. Remember to immediately remove the handpiece from the autoclave at the end of the sterilizing process.
6. It is inadvisable to sterilize handpieces using the night cycle.

It is essential to place a chemical indicator in the autoclave on each cycle, to ensure that the sterilizing process has taken place correctly.

7.3 Messaggi visualizzati dal display

P1	Cycle 121°
P2	Cycle 134°
dr	Dry cycle
He	Heating
St	Steril

8. STERILIZING CYCLES

8.3 Sterilizing table

<i>Cycle</i>	<i>Materials</i>	<i>Max. load (Kg)</i>	<i>Sterilizing minutes with machine cold</i>	<i>Sterilizing minutes with machine hot</i>	<i>Drying minutes</i>	<i>Operating pressure (bar)</i>	<i>* Effective sterilization minutes not less than</i>
<i>Non-packeted</i> 121°C	- metallic solids - rubber materials - plastic materials - glassware	1	25	23	5	1,1 - 1,2	15
<i>Packeted</i> 121°	- delicate solids - rubber materials - plastic material - glassware - wrapped handpieces	1	35	33	5	1,1 – 1,2	25
<i>Non-packeted</i> 134°	- stainless metallic solids	1	20	18	5	2,1 – 2,2	10
<i>Packeted</i> 134°	- stainless metallic solids - protected cutters	1	25	23	5	2,1 – 2,2	15
<i>Packeted handpieces</i> 121°	- wrapped handpieces	0,5	25	23	5	1,1 – 1,2	15

* Until he has acquired enough experience in using the autoclave, the operator must check to make sure that the operating pressure does not last less than the minimum effective sterilization minutes indicated in the table.

Increase the number of minutes that sterilizing must last if these parameters are not complied with. The sterilizing table contains indicative data. It is essential to consult the values established by the manufacturer of the materials to be sterilized and to strictly comply with the sterilizing parameters indicated by the current standards in force.

If the autoclave is used to sterilize instruments contaminated by CREUTZFELDT-JAKOB's disease, use the 134° cycle and sterilize for 20 minutes with a cold start or 20 minutes with a hot start.

It is advisable to use non-packeted sterilized materials immediately. Packeted sterilized instruments can be placed in a UV glass case to ensure that they remain sterilized (for short periods).

8.2 Notes and warnings

- 1- Strictly comply with the manufacturer's instructions when sterilizing materials.
- 2- To preserve packaged and loose sterilized materials, the trays must be stored in special cabinets fitted with ultraviolet lamps and designed for this specific use.
- 3- Whenever a sterilizing process is carried out, it is advisable to add a chemical indicator that we can supply on request, code 1468.

VAPOR LINE™
propper **PASS**
FAIL U.S. Pat. D347585
STEAM STERILIZATION INTEGRATOR

U.S. Pat. 5,158,363

VAPOR LINE™ Extender

LOT NO.
DATE

VAPOR LINE™
**Integratore per la
sterilizzazione a vapore con
estensore munito di indicatore**
propper manufacturing co., inc.
36-04 Skillman Avenue, Long Island City, NY 11101

Reorder No. 269008 **250 Integrators**

ISTRUZIONI PER L'USO

1. Posizionare un integratore VAPOR LINE in ogni pacco da sterilizzare. Inserire l'integratore nell'area più resistente alla penetrazione del vapore. Posizionare l'estensore in modo che l'estremità finale dello stesso sporga dall'involucro interno e sia immediatamente visibile una volta che l'involucro esterno sia stato rimosso.
2. Procedere alla sterilizzazione del pacco in autoclave.
3. All'apertura dell'involucro esterno esaminare la punta finale dell'estensore dell'integratore. Se tale estremità è diventata di colore scuro la sterilizzazione è avvenuta in modo corretto; in caso contrario, e cioè tale cambiamento non si è verificato, procedere alla risterilizzazione del pacco.
4. A questo punto estrarre l'integratore dal pacco. Esaminare il VAPOR LINE per verificare che la barra scura abbia superato la zona rossa denominata "FAIL" fino a raggiungere la zona verde denominata "PASS". Questa è la prova che le condizioni di sterilizzazione si sono verificate.
5. Nel caso in cui la barra scura non abbia raggiunto la zona verde "PASS", il processo di sterilizzazione non è stato correttamente completato. L'intero pacco dovrà essere ripreparato e sterilizzato nuovamente inserendo un nuovo integratore VAPOR LINE.
6. La busta aperta può essere ripiegata nella sommità al fine di conservare in modo ottimale il prodotto.

LOT NO. 99222

MFG. DATE / DATA DI FABBRICAZIONE: **1999-10**
EXPIRATION DATE / DATA DI SCADENZA: **2003-10**

DO NOT USE AFTER EXPIRATION DATE
NON UTILIZZARE DOPO LA DATA SCADENZA

STORE AT 15-30 DEGREES C°
CONSERVARE A 15-30 GRADI C°

KEEP IN COOL DRY PLACE IN THE ORIGINAL POUCH
CONSERVARE IN AMBIENTE NON UMIDO E IN
CONFEZIONE ORIGINALE

98/1 13069216

9. FAULTS

9.1 Troubleshooting: Solutions / Remedies

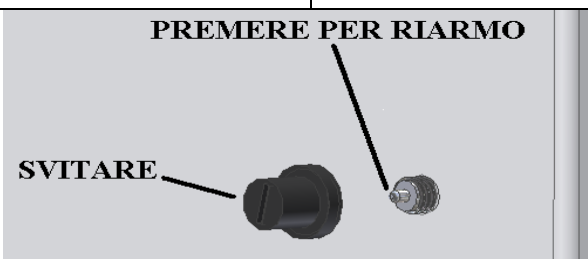
FAULTS	CAUSES	REMEDIES
The timer fails to operate (5)	- Board burnt-out	- Replace the board
	- Power is not reaching the board	- Check fuse F1A on the board with a tester
The pressure gauge (6) remains at a standstill even during the sterilizing cycle	- Pressure gauge (6) blocked or broken	- Clean the tube or replace the pressure gauge
	- No water in the chamber	- Repeat the cycle
Water remains in the chamber	- The dry indicator light (1) remains on and the water is not drained	- Replace or check the draining solenoid valve
The machine fails to pressurize during the cycle	- The heating element has burnt out	- Replace the heating element
	- The wire has detached from the heating element	- Re-connect the wire
	- The safety thermostat has tripped	- Press the reset alongside the control panel
		
	- Switch (7) faulty	- Replace the switch
Insufficient pressure for the selected cycle with indicator lights (2) and (3) permanently on	- The bulb thermostat setting is incorrect	- Slightly turn the thermostat in the clockwise direction
	- Not enough water in the boiler	- Comply with the instructions
	- Leaks from the door seal	- Clean the seal and the chamber
The pressure increases very slowly	- Chamber very dirty inside	- Clean the chamber as described in the maintenance section
	- Heating insufficient	- Heating element rods loosened
	- Too much vapour issues from the breather union	- Replace the complete breather union
The machine is not powered when the switch (7) is turned on	- Defective switch	- Replace the switch and check the wires
	- No power is reaching the mains socket	- Check the socket and electricity main
	- Fuses in the machine burnt out	- Remove the casing and replace them with fuses of an equal value after having made sure that there are no short-circuits
The door fails to open with the machine hot and the pressure gauge below Ø	- Vacuum in the chamber	- Check the drain can and relative tube.

10. MAINTENANCE



Carry out the maintenance operations with the machine at a standstill, after having removed the plug from the power socket and after having allowed the components to cool down.

The declaration of conformity to the standards in force is not valid unless the maintenance operations described below are carried out.

10.1 General maintenance

The machine needs to be serviced in a particular way. Users are therefore advised to comply with the below listed recommendations:

- Periodically check the condition of the electrical system with particular attention to the connection cable. **Contact our Technical Assistance Service or specialized personnel if faults are discovered.**
- Periodically clean the door, the seal and take particular care when cleaning the **internal part of the boiler**, removing any scaling with the damp sponge (supplied with the machine). Correct cleaning of these parts of the machine will ensure that the sterilizing cycle takes place in the right way.
- If the machine is not to be used for a long period of time, leave the door ajar and store it at a room temperature of $>8^{\circ}\text{C}$.
- Use a damp cloth to clean the casing of the machine. Never ever use inflammable liquids for any reason whatsoever.

10.2 Daily routine maintenance

Clear the door seal, door window and generally clean the outer and inner surfaces of the machine.

Clean the black silicone door seal, the outer and inner edges and the part where the door rests on the sterilizing chamber and on which the seal must tightly fit. Use the supplied sponge to do this. The soft part of the sponge can be used to clean the seal while the rough part can be used to clean the edge of the chamber.

This cleaning operation must be carried out regularly to remove all impurities that could lead to loss of pressure inside the sterilizing chamber.

Check the used water level and drain off the actual water into the sewer if necessary. Then wash out the can under running water.

10.3 Weekly routine maintenance

Cleaning the sterilizing chamber / cleaning the trays and tray holders.

As specified in section 10.1 “ General maintenance “, all traces of deposits must be removed from the bottom of the chamber. Use the rough side of the supplied sponge for this operation, attempting to eliminate any scaling that may have formed.

Rinse everything with the same water used for the sterilizing process. The trays and tray-holders must also be cleaned in this way.

Drain the water and clean the tray.

10.4 Monthly routine maintenance

Lubricate the pins and locking mechanisms.

Check the movement of the hinge and door locking pin. Lubricate with Vaseline oil.

Make sure that the door is well regulated. If it is excessively slack, it must be adjusted by means of the supplied wrench. Turn the regulator at the rear of the door in a (A) direction. This will increase the pressure exercised by the seal.

Attempt to shut the door. If some difficulty is encountered, turn the regulator in a (B) direction.

Clean the entire autoclave cabinet with a slightly damp sponge, including the door casing.

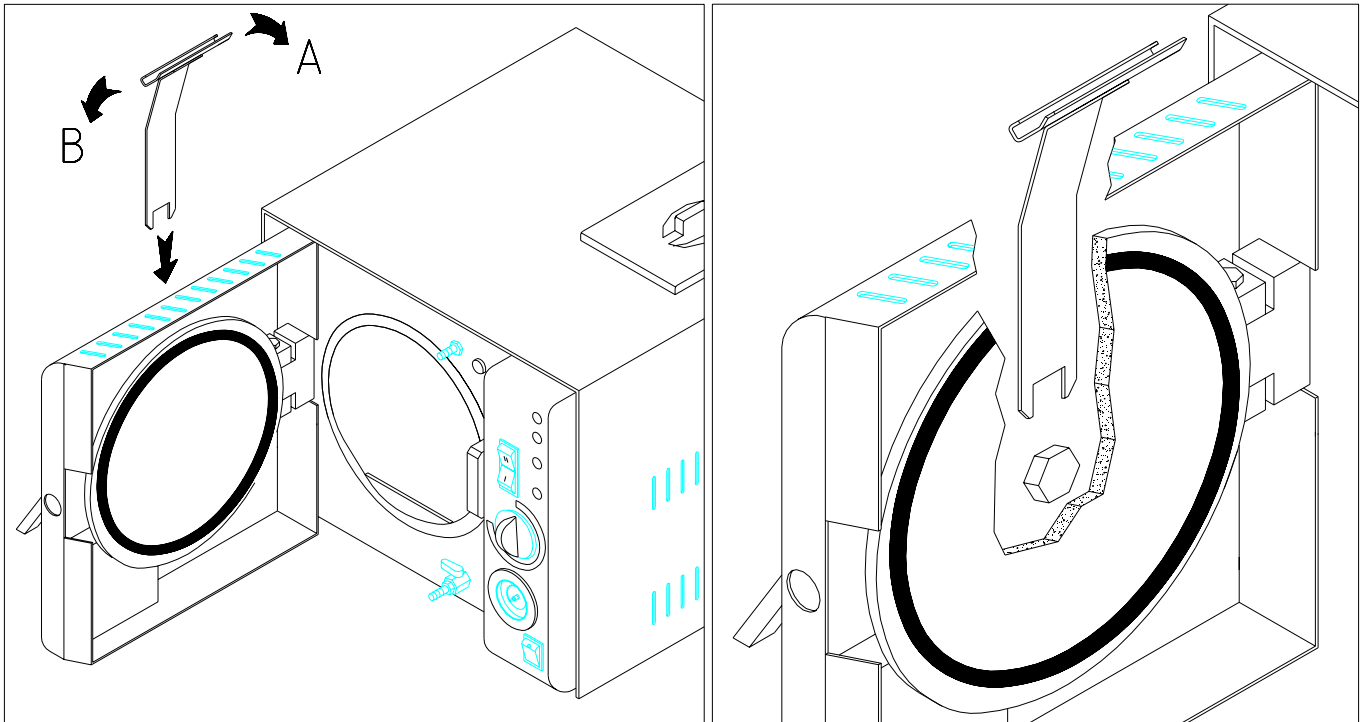

10.5 Periodic extraordinary maintenance

To allow the autoclave to operate in a regular way, the manufacturer advises users to carry out a functional test to ensure that the temperature and pressure parameters of the machine comply with the standards required for a correct sterilizing process.

These tests must be conducted by personnel authorized by the manufacturer, using calibrated and periodically certified instruments.

The autoclave can also be sent to the manufacturer for this test, after form 32/A has been filled out and accepted.

The autoclave is able to accept probes for the sterilizing tests.

It is advisable to have the appliance subjected to a Total Overhaul by After-sales Service staff at least once every 12 months.

The operation of the safety valve installed at the rear of the machine must also be checked at least once every 12 months. This is done by removing the protective casing and re-tightening the ring nut of the valve by hand. To prevent accidents, this operation should obviously be carried out when the machine is cold and off.

ELECTRICAL SYSTEM :

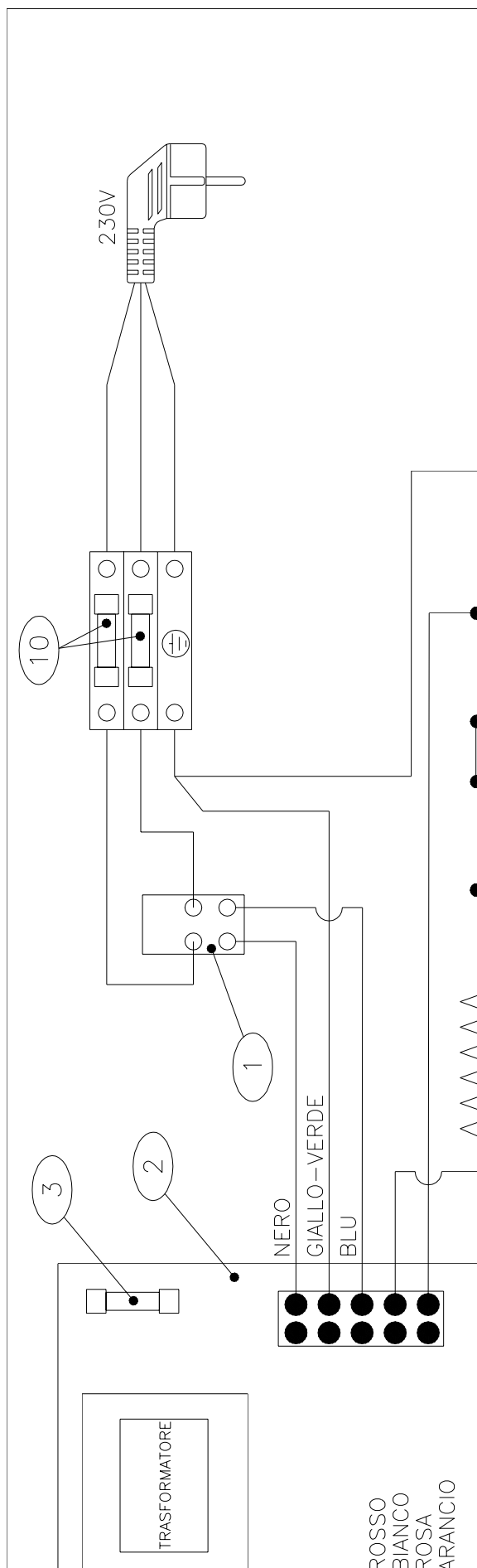

HYDRAULIC PLANT :

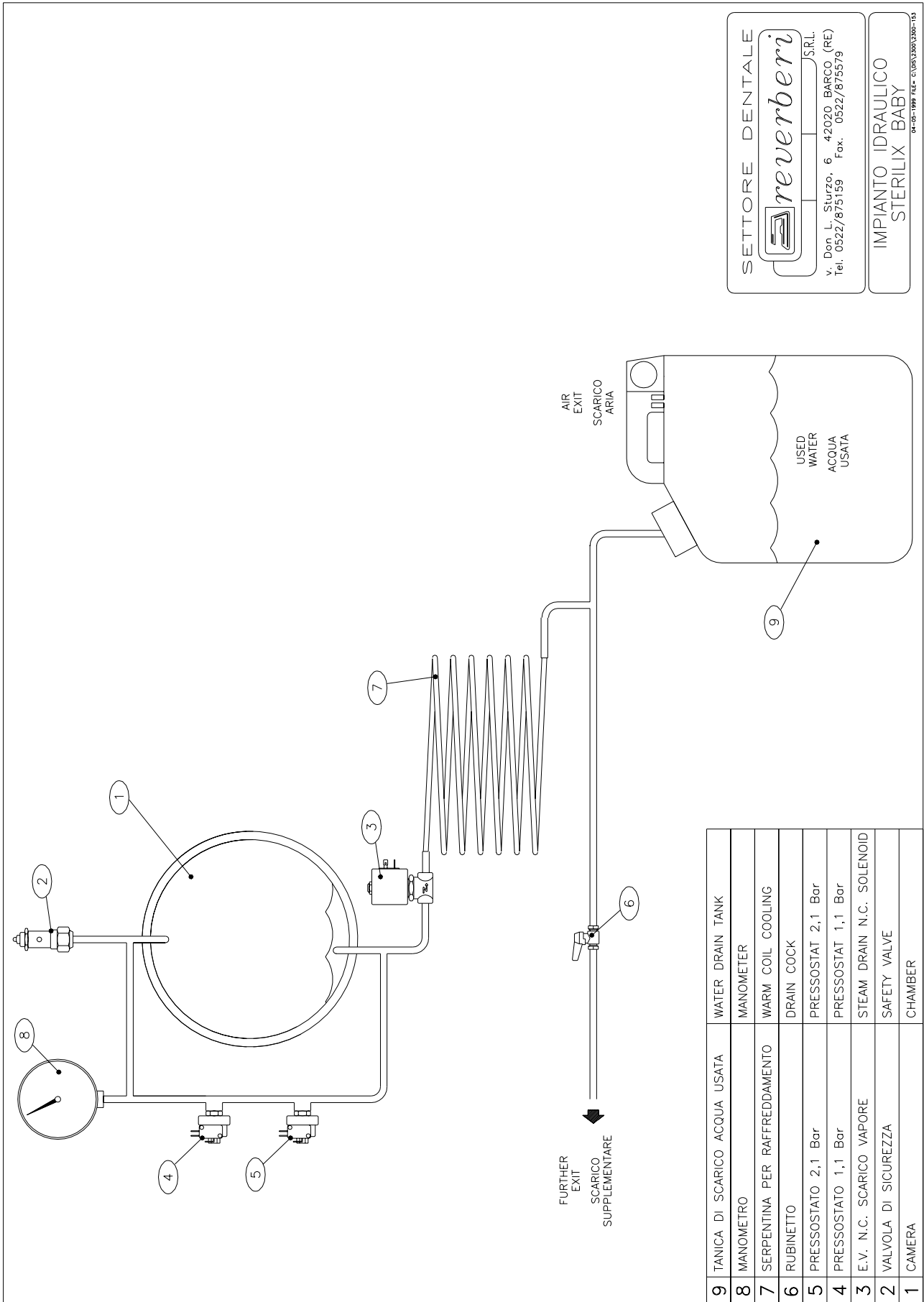

SETTORE DENTALE
 **reuerber** S.R.L.
 v. Don L. Sturzo, 6 - 42020 BARCO (RE) (RE)
 Tel. 0522/875159 - Fax. 0522/875579
IMPIANTO IDRAULICO
STERILIX BABY
04-05-1999 REC- C/US/3250/2300-153

SPARE PARTS

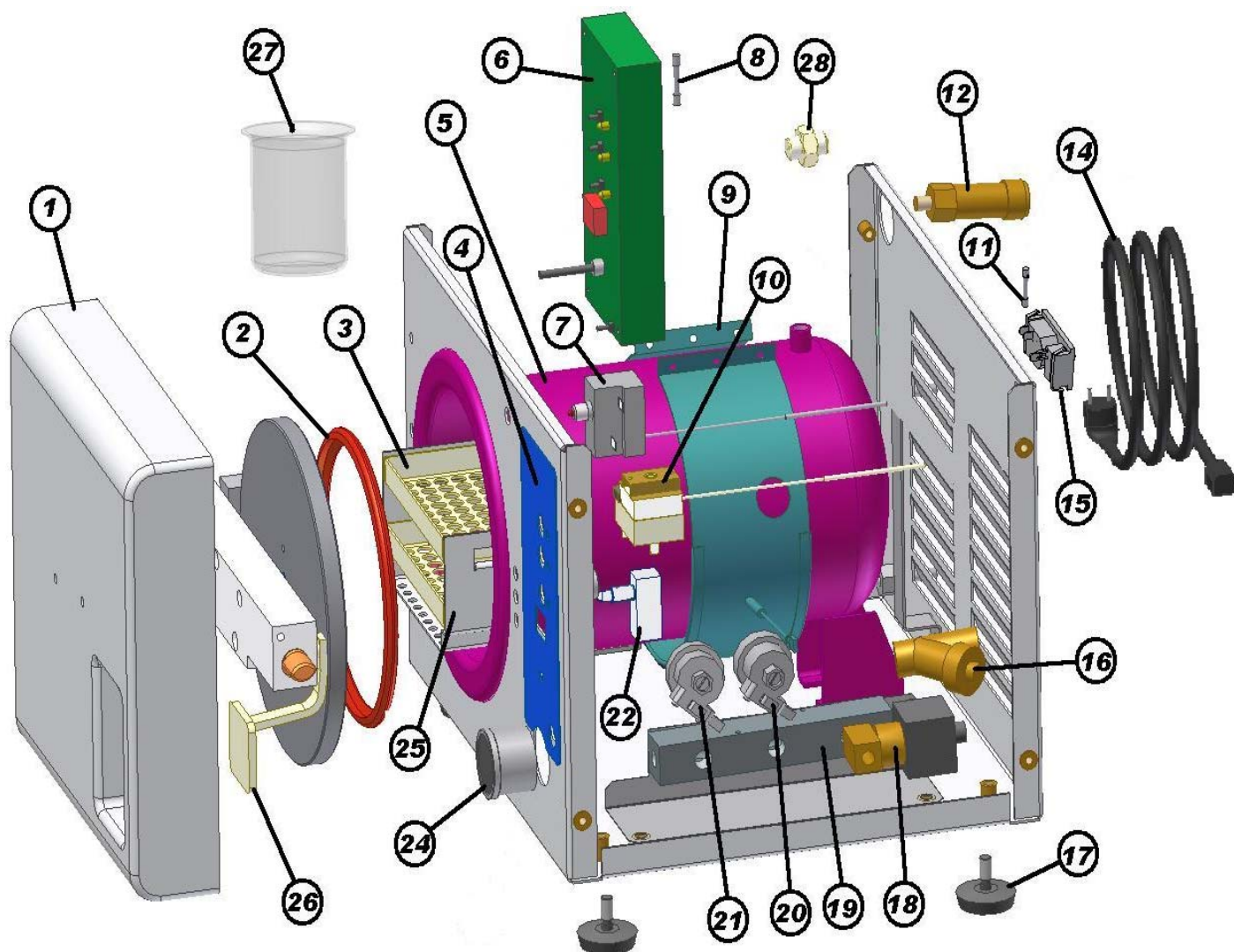

14	4404	Cavo con spina	1
12	1374	Valvola di sicurezza	1
11	1542	Fusibile 5x20 T10A	1
10	0396	Termostato automatico	1
9	3937	Resistenza 500W	1
8	3862	Fusibile 20x4 F1A	1
7	3461	Termostato manuale	1
6	3938	Scheda elettronica	1
5	3910	Cuve 7 litri	1
4	4013	Serigrafia q. comandi	1
3	3969	Tray forato	1
2	3954	Guarnizione portello	1
1	4027	Carter porta	1
POS.	COD.	DESCRIZIONE	Q.TA'

28	3236	Sfiato termodinamico	1
27	3848	Beaker 250 ml	1
26	3071	Maniglia verniciata	1
25	3968	Porta tray	1
24	1730	Manometro Ø40	1
22	0339	Micro interruttore	1
21	2853	Pressostato 2.1bar	1
20	2852	Pressostato 1.2bar	1
19	3023	Collettore pressostati	1
18	1357	Elettrovalvoa n.a.	1
17	0336	Piede regolabile	4
16	3136	Filtro a Y	1
15	4380	Polisnap	1
POS.	COD.	DESCRIZIONE	Q.TA'

 <p style="text-align: center;">Via Don Luigi Sturzo n°6 42021 BARCO (Reggio Emilia) ITALY Tel. 0039 (0) 522 / 875159 Fax 0039 (0) 522 / 875579</p>	<p>FORM TO FILL OUT WHEN APPLIANCES ARE RETURNED FOR REPAIRS</p>	<p>To be filled out by the: Installer or authorized person</p>
--	---	--

Autoclave mod.	Serial N°
At	
Situating in address	
Purchase invoice N° of	
Issued by Company	
Date of first installation by Mr.	
Was the warranty form sent to the manufacturer when appliance was first installed? <input type="checkbox"/> yes <input type="checkbox"/> no	

Reason why the machine must be sent back to the Manufacturer:	
PERIODIC CALIBRATION <input type="checkbox"/>	REQUEST FOR REPAIR UNDER GUARANTEE <input type="checkbox"/>
REPAIR SUBJECT TO PAYMENT <input type="checkbox"/>	OTHER..... <input type="checkbox"/>

FAULT ENCOUNTERED:
--

<p>BEFORE SENDING BACK THE AUTOCLAVE, PLEASE COMPLY WITH THE FOLLOWING INSTRUCTIONS:</p> <ol style="list-style-type: none"> 1. Before sending back the machine, fill out this form and send it via fax to N° 0039 0522 875579 and send us free of charges. In case of non accepted repair estimate, will be invoiced € 50,00. 2. The warranty will become void if the machine is sent back without prior authorization. 3. Empty the used water from the tank. 4. Place a folded piece of newspaper between the door and chamber and then shut the autoclave to prevent one of the two parts from being damaged during transport. 5. Remove the tray-holder. Do not send it back with the machine. 6. Send the autoclave packed in the original wrapping in which it was purchased. 7. Install the substitute machine (if applicable) in compliance with the recommendations in the maintenance manual. 	<input type="checkbox"/> <input type="checkbox"/> <input type="checkbox"/> <input type="checkbox"/> <input type="checkbox"/> <input type="checkbox"/> <input type="checkbox"/> <input type="checkbox"/>
---	--

<p>The installer hereby declares that the indicated operations have been carried out, that the machine supplied as a <u>substitute</u> has been installed in compliance with the instructions in the maintenance manual and that it functions perfectly. The technician also declares that the form with the test results of the first installation has been filled out and sent off along with the warranty form.</p> <p>Date Installer's signature</p>
--

It is obligatory for the installer to fill out all parts of this form and to declare that he has complied with all the conditions ensuring that the appliance is correctly installed in compliance with sect. 5.1 of the instruction manual.

The installer also declares that he has duly trained the user to operate the machine, with the help of the instruction manual.

The technician declares that he has attached the printer ticket to this form along with the warranty form, duly filled out in all parts.

The above mentioned documents must be immediately forwarded to the manufacturer.

Notes and/or considerations
.....
.....
.....

Installer's signature and date

.....

WARRANTY

This document certifies that the appliance has been correctly manufactured.

Carefully read the instruction manual before forwarding complaints.

The appliance will be repaired if it operates in a faulty way during the warranty period owing to manufacturing defects, the manufacturer's judgement over such matters being final.

The appliance is covered by guarantee for a period of 5 (five) years from the date of purchase. This date shall be testified by the enclosed coupon (B), which must be filled out, duly stamped and signed by the installer technician and countersigned by the end user, in accordance with directives EC 93/42 according to which it must be possible to trace a product.

Our sales form (DDT) indicating the serial number of the appliance shall bear witness in the event of disputes.

The electrical, electronic parts and nuts and bolts are guaranteed for a period of 12 (twelve) months.

The warranty covers the sole replacement or repair of those parts recognized as possessing manufacturing defects, with the exclusion of expenses for:

- Transfers
- Call rights
- Mileage reimbursement
- Shipment

Replaced parts shall be returned free port. The ordering party shall be charged for any part that is not returned.

All appliances returned for repairs shall only be sent to us free port after authorization and compilation of form 32/A (also in photostat copy form).

The appliances must be sent to us adequately packed in their original wrapping clearly indicating the sender, his address and the claimed defect.

All appliances must be set free port.

THE WARRANTY SHALL BECOME VOID:

1. If the appliance has been repaired, modified or tampered with by the purchaser or by unauthorized third parties.
2. If the purchaser fails to contact the seller or authorized technical center.
3. If the customer and/or reseller delays or suspends payments.
4. If the appliance has been damaged by exposure to fire, spilt liquids, natural disasters, has been dropped or damaged by causes that are not ascribable to manufacturing defects.
5. When the warranty form has not been duly filled out, signed and returned within the established time.
6. If the customer fails to use the appliance correctly.
7. If the appliance is not serviced correctly or is used improperly.

WARRANTY CERTIFICATE and stamped

APPLIANCE:

The undersigned reseller certifies that the warranty has been examined and certifies that the appliance has been consigned and installed in compliance with the instructions given

by the manufacturer on:.....

By Mr.

Address

ZIP Code City

1 – FOR THE PURCHASER

<p style="text-align: center;">.....</p> <p>TECHNICAL INSTALLER SIGNATURE AND STAMP*</p>	 Via Don Luigi Sturzo, 6 42021 BARCO (Reggio Emilia) ITALY
---	--



THIS PART OF THE CERTIFICATE MUST BE SENT BACK BY REGISTERED LETTER WITHIN 8 DAYS FROM THE DATE OF PURCHASE

WARRANTY CERTIFICATE

TO BE RETURNED SIGNED AND STAMPED

APPLIANCE:

The undersigned reseller certifies that the warranty has been examined and certifies that the appliance has been consigned and installed in compliance with the instructions given

by the manufacturer on:.....

By Mr.

Address

ZIP Code City Buyer signature.....

2 –FOR THE MANUFACTURER

<p style="text-align: center;">.....</p> <p>RESELLER'S SIGNATURE AND STAMP</p>	 Via Don Luigi Sturzo, 6 42021 BARCO (Reggio Emilia) ITALY
---	--

*** The technical installer must be authorized by the building factory.**

 <p>Via Don Luigi Sturzo n°6 42021 BARCO (Reggio Emilia) ITALY Tel. 0039 (0)522 / 875159 Fax 0039 (0)522 / 875579</p>		To
--	--	----

BARCO, 03-01-07

SUBJECT: TRACEABILITY OF THE AUTOCLAVES

REVERBERI S.R.L. IS OBLIGED TO BE ABLE TO TRACE ITS PRODUCTS THROUGH TO THE END USER (PHYSICIANS, DENTAL STUDIOS, MEDICAL LABORATORIES).

THUS, THE PERSON IN CHARGE OF THE WAREHOUSE AND/OR THE DEALER SHALL OBLIGATORILY KEEP THE TRANSPORT DOCUMENTS BEARING THE SERIAL NUMBERS OF THE AUTOCLAVES IN THEIR FILES FOR AT LEAST 10 (TEN) YEARS. ALTERNATIVELY, THEY SHALL KEEP A LIST OF THEIR END USER CUSTOMERS TO WHOM THE SERIAL NUMBERS OF THE CONSIGNED AUTOCLAVES ARE ASSOCIATED.

IT MUST ALSO BE POSSIBLE TO TRACE THE AUTOCLAVES (THE SERIAL NUMBER OF THE MACHINE MUST CORRESPOND TO THE END USER CUSTOMER) EVEN WHEN THEIR FINAL DESTINATION CHANGES (AUTOCLAVES THAT CHANGE HANDS FROM ONE CUSTOMER TO ANOTHER).

SHOULD REVERBERI S.R.L. BE PREVENTED FROM TRACING THE PRODUCT (TO HAVE IT RETURNED TO THE COMPANY, FOR EXAMPLE) OWING TO FAILURE OF THE PERSON IN CHARGE OF THE WAREHOUSE OR THE DEALER TO FULFILL THIS REQUIREMENT, IT SHALL BE OBLIGED TO INFORM THE COMPETENT AUTHORITIES AND THE NOTIFIED BODY OF THIS NON-PERFORMANCE AND RESERVES THE RIGHT TO CLAIM REIMBURSEMENT OF THE DAMAGES DERIVING FROM FAILURE TO TRACE THE PRODUCT FROM THE PERSON IN CHARGE OF THE WAREHOUSE AND/OR FROM THE DEALER IN QUESTION.

REVERBERI MANAGEMENT

WAREHOUSE OR DEALER’S REPRESENTATIVE

SIGN FOR ACCEPTANCE AND RETURN TO REVERBERI



Via Don Luigi Sturzo n° 6
 42021 BARCO (Reggio Emilia)
 Tel. +39 – 0522 - 875159 / 875195
 Fax +39 – 0522 - 875736 / 875579
 ITALIA

**DICHIARAZIONE DI CONFORMITÀ. DECLARATION DE CONFORMITÉ.
 DECLARATION OF CONFORMITY.
 DECLARACION DE CONFORMIDAD. KONFORMITATSERKLARUNG.**

*STERILIZZATRICE A VAPORE. MACHINE POUR STERILISER A VAPEUR. STEAM
 STERILIZER MACHINE. ESTERILIZADORAS DE VAPOR. DAMPFSTERILISATOREN.*

<i>Mod:</i> M9010/56	<i>Art.</i> STERILIX BABY	
--------------------------------	-------------------------------------	--

La Reverberi s.r.l. dichiara sotto la propria responsabilità che i prodotti elencati sono conformi alle norme:

La maison Reverberi s.r.l. déclare sous sa responsabilité que les produit enumeres sont conformes aux directives:

The company Reverberi s.r.l. declare under own exclusive responsibility that the product listed are in conformity with the normatives:

Reverberi s.r.l. declara bajo su propia responsabilidad que los productos mencionados estan conformes a las normas siguientes:

Reverberi s.r.l. erklart unter seiner cigenen verantwortung, daB die aufgelisteten produkte den vorschriften:

**EN 61010-1 : 1993 + A2 : 1995, EN 61010-2-041 : 1996,
 EN 61000-3-2 : 1995 + A1 : 1998 + A2 : 1998,
 EN 60555-3 : 1987+A1 : 1991, EN 55011 : 1998, EN 50082-2 : 1995,
 EN97/23CE, EN 94/62CE.**



BARCO (RE)
 03-01-2007

.....
 (Pres. REVERBERI ARNALDO)