

Service Record Book for Sigma Elite Vaporizer

Cat. No.	Agent
Serial No.	
Date of Installation	
Departmental No.	
Serviced by	
Contact telephone	

THIS BOOK SHOULD BE KEPT IN THE DEPARTMENT
OF ANAESTHESIA RECORDS AND UPDATED AT
EACH SERVICE BY THE SERVICE ENGINEER.

SERVICE POLICY

The Sigma Elite Vaporizer must be serviced according to the following system:

- a) The calibration should be checked periodically under controlled conditions and leak tests performed.

See section 6.3 in the service manual.

The measured figures should be recorded in this Service Record Book, see pages 11 to 20.

At the completion of the first Five Year Overhaul, a copy of pages 11 to 15 must be faxed to Penlon Limited (Fax No: 44 1235 547031).

At the completion of the second Five Year Overhaul, a copy of pages 16 to 20 should be faxed to Penlon Limited (Fax No: 44 1235 547031).

- b) By comparing several sets of successive figures, a trend in performance can be established and a service performed before the standard tolerance is exceeded.
- c) If the calibration check shows a departure from the standard performance or a trend towards predicted failure, the vaporizer must be serviced as described in section 6 of the service manual.
- d) All vaporizers must be overhauled every 5 years and certain items replaced even if the performance appears satisfactory.
This is a preventive maintenance requirement.
- e) This book may be used to record the repair and servicing work carried out on the vaporizer, see page 7, in this book.

USER RESPONSIBILITY

This vaporizer has been built to conform with the specification and operating procedures stated in the user and service manuals and/or accompanying labels and notices, when checked, assembled, operated, maintained and serviced in accordance with these instructions provided. To ensure the safety of this vaporizer it must be checked and serviced to at least the minimum standards laid out in these manuals. A defective or suspected defective, product must not, under any circumstances be used.

The user must accept responsibility for any malfunction which results from non-compliance with the servicing requirements detailed in the user manual.

Worn, broken, distorted, contaminated or missing components must be replaced immediately. Should such a repair become necessary it is recommended that a request for service advice is made to the nearest Penlon service centre.

This vaporizer and any of its constituent parts must be repaired only in accordance with written instructions issued by Penlon Ltd. and must not be altered or modified in any way without the written approval of Penlon Ltd. The user of this equipment shall have the responsibility for any malfunction which results from improper use, maintenance, repair, damage or alteration by anyone other than Penlon Ltd. or its appointed agents.

This vaporizer must only be supplied to, and used by, suitable qualified medical practitioners. Caution, USA and Canadian Federal Law restricts the sale and use of this device by or on the order of a physician.

Notes on Calibration procedure using the Riken analyser

The Riken Model 18 is normally supplied calibrated for halothane 0–6% vol., either in air or in oxygen.

Service checks on the vaporizer will be performed with oxygen if the vaporizer is checked on an anaesthetic machine, and may be performed with air or with oxygen in a test laboratory.

CAUTION *It is essential that the gas used is recorded, and that the reference cell of the Riken is purged with the appropriate gas before measurements are made.*

AGENTS

The Riken gas analyser measures the refractive index of the gases and vapours and, although normally calibrated for measuring halothane, the instrument can also measure other vapours if an appropriate correction factor is applied.

The correction factors below are applied by multiplying the reading of the Riken to obtain the true concentration.

CARRIER GAS

The refractive index of oxygen is higher than that of air so that, (a) the unit must be re-zeroed if the carrier gas is changed, and (b) the scale must be adjusted by a correction factor, applied by multiplying the Riken scale reading to obtain the true concentration.

Correction Factors:

Halothane in Air Riken

	Factor (using air)	Factor (using oxygen)
Halothane	1	1.06
Enflurane	1.05	1.11
Isoflurane	1.06	1.12
Sevoflurane	1.05	1.10

Halothane in Oxygen Riken

	Factor (using air)	Factor (using oxygen)
Halothane	0.95	1
Enflurane	0.99	1.05
Isoflurane	1	1.06
Sevoflurane	0.99	1.05

TEMPERATURE AND BAROMETRIC PRESSURE

Calibration checks must be performed at a temperature between 19 and 21 °C. The correction factor is $\pm 1.5\%$ of readings, which is negligible in view of the accuracy of the instrument. Temperature correction is therefore not required, but the temperature should be measured and recorded to ensure that the test is carried out within the specified range.

Changes of barometric pressure due to weather are not normally of significance and can be ignored.

Altitude can, however, have significant effects and the following correction factors should be applied when appropriate

The Riken reading multiplied by the stated correction factor gives the true concentration corrected to Standard Temperature and Pressure (STP).

Altitude	Factor	Barometric pressure (for reference)
600 m (2000 ft)	0.9	910 mb
1200 m (4000 ft)	0.85	850 mb
1800 m (6000 ft)	0.8	813 mb

Method of reading the Riken Analyser

1. Readings may be taken from a tee-piece connected to the common gas outlet of the anaesthetic machine. An AGS system must be connected.
2. The sampling tube must be nylon or PTFE (which do not absorb vapours). Rubber sleeves may be used to make end connections but there must be minimal length of rubber exposed to the gases being sampled.
3. Sample by 2 or 3 squeezes of the hand bulb. Wait for fringe movement to cease before taking the reading.
4. After each resetting of the vapour control, time must be allowed for the output to stabilize.
Suggested timescale: at 2 L/min flow – wait 4 minutes
4 L/min flow – wait 2 minutes
8 L/min flow – wait 1 minute
5. As stated in the Service Manual:
 - a) The vaporizer must be half full, and rigidly supported in its operating position
 - b) Temperatures must be stabilized for approximately 4 hours before checking
 - c) The temperature must be in the range 19 to 21 °C.

SERVICE RECORD

Give details of any servicing, component replacements, etc., carried out on the vaporizer.

Date	Comments (including any additional work)	Signature

CALIBRATION RECORD – YEAR ONE

Write the serial number of the vaporizer and print your name in the Comments section.

Test Period		1	2	3	4
Date					
Signature					
Carrier Gas					
Overall leak rate: Must be less than 200 ml/min at 150 mm Hg.					
Set	Tolerance				
0.0	0 - 0.1				
0.4	0.3 - 0.5				
1.0	0.8 - 1.2				
3.0	2.4 - 3.6				
5.0	4.0 - 6.0				
* 7.0	5.6 - 8.4				
* 8.0	6.4 - 9.6				
* 7.0	5.6 - 8.4				
5.0	4.0 - 6.0				
3.0	2.4 - 3.6				
1.0	0.8 - 1.2				
0.4	0.3 - 0.5				
0.0	0 - 0.1				
* 7% and 8% vaporizers only					
Bypass resistance at 4 L/min					

Comments:

Penlon



Penlon Ltd, Abingdon Road, Abingdon, Oxfordshire, OX14 3PH, UK. Tel: 01235 547001 Fax: 01235 547021 Service Fax: 01235 547031 E-mail: service@penlon.co.uk export@penlon.co.uk uksales@penlon.co.uk

Penlon



Penlon Ltd, Abingdon Road, Abingdon, Oxfordshire, OX14 3PH, UK. Tel: 01235 547001 Fax: 01235 547021 Service Fax: 01235 547031 E-mail: service@penlon.co.uk export@penlon.co.uk uksales@penlon.co.uk

Sigma Elite Vaporizer User Instruction Manual

CE0120

Cat. No. 54535
Doc. No. PE198 UI
July 1998

Copyright © Penlon Ltd 1998. All Rights Reserved.

Penlon Ltd, Radley Road, Abingdon, OX14 3PH, UK.
Tel: 01235 547001 Fax: 01235 547021 Service Fax: 01235 547031
E-mail: service@penlon.co.uk export@penlon.co.uk uksales@penlon.co.uk

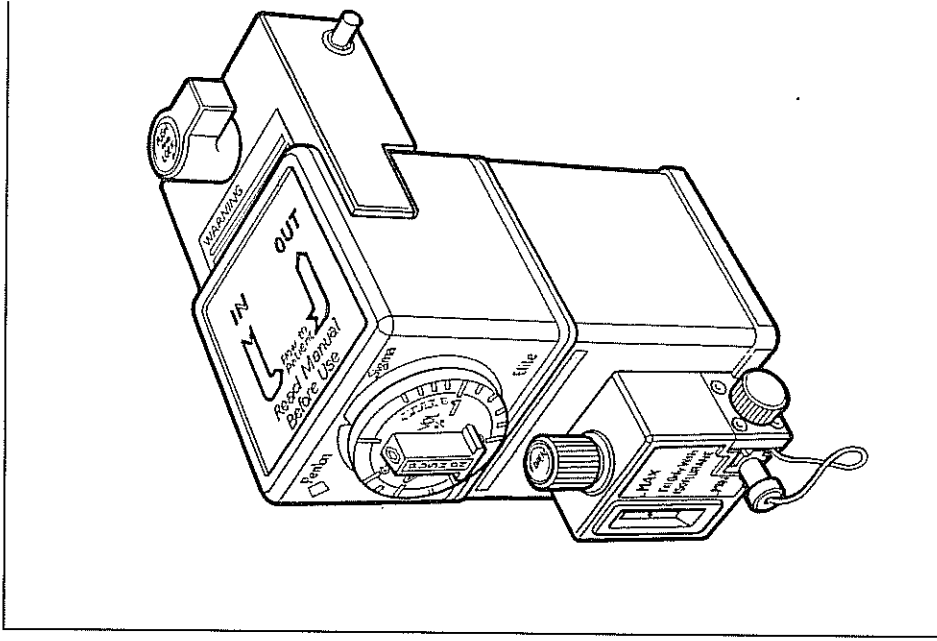

Quality and Assurance in Anaesthesia

IMPORTANCE OF PATIENT MONITORING

WARNING

Anaesthetic systems have the capability to deliver mixtures of gases and vapours to the patient which could cause injury or death unless controlled by a qualified anaesthetist.

There can be considerable variation in the effect of anaesthetic drugs on individual patients. Consequently, the setting and observation of control levels on the anaesthesia systems does not in itself ensure total patient safety.

Anaesthesia system monitors and patient monitors are very desirable aids for the anaesthetist but are not true clinical monitors as the condition of the patient is also dependent on his respiration and the functioning of his cardio-vascular system.

IT IS ESSENTIAL THAT THESE ELEMENTS ARE MONITORED FREQUENTLY AND REGULARLY AND THAT ANY OBSERVATIONS ARE GIVEN PRECEDENCE OVER MACHINE CONTROL PARAMETERS IN JUDGING THE STATE OF A CLINICAL PROCEDURE.

IMPORTANT

Service and Repairs

In order to ensure the full operational life of the Sigma Elite vaporizer, servicing by a Penlon trained engineer should be undertaken periodically.

We recommend that a service check should be performed periodically, comprising a vaporizer CALIBRATION CHECK and LEAK CHECK.

Note:

(a) The calibration check must be performed using a suitable agent analyser, e.g. a Riken refractometer or infrared analyser.

(b) The service check is part of the recommended pre-use check for your Anaesthesia System.

Should the calibration check show the unit to be outside the specified performance requirement (e.g. $\pm 20\%$ of scale reading) then a basic service must be performed. A Service Record Book is provided to maintain a record of the vaporizer's performance.

This may be done on site by:

- (a) A trained user.
- (b) An authorized Penlon agent.
- (c) A Penlon service engineer.

For any enquiry regarding the service or repair of this vaporizer, contact the nearest accredited Penlon agent* or contact the Service Department at Penlon Ltd.

*Agent's name and address:

Service and Repair Department
Penlon Ltd
Abingdon, Oxford
OX14 3PH
UK

Tel: 01235 547001
Fax: 01235 547031
E-mail: service@penlon.co.uk

Always give as much of the following information as possible:

1. Type of equipment
2. Product name
3. Serial number
4. Approximate date of purchase
5. Apparent fault

FOREWORD

This manual has been produced to provide authorized personnel with information on the function, routine performance and maintenance checks, applicable to the Penlon Sigma Elite vaporizer.

Information contained in the manual is correct at the date of publication. The policy of Penlon Ltd is one of continued improvement to its products. Because of this policy Penlon Ltd reserves the right to make any changes, which may affect instructions in this manual, without giving prior notice.

Personnel must make themselves familiar with the contents of this manual before using the vaporizer.

Terminology used in this manual complies with ISO 4135, Anaesthetic Apparatus Terminology.

The following additional definitions should be noted:

% Vol. - shortened form of volumetric percentage. The commonly used method of expressing vapour concentrations so that they can be compared with concentrations of true gases. 100 Vol.% is equivalent to 100% partial pressure in a mixture.

Copyright © Penlon Ltd, 1998
All rights reserved.

CONTENTS

USER RESPONSIBILITY	5
1. WARNINGS AND CAUTIONS	6
2. PURPOSE	11
3. DESCRIPTION	13
3.1 Operating Principles	13
3.2 Controls	13
4. SPECIFICATION	15
4.1 Physical Dimensions	15
4.2 Weight	15
4.3 Capacity	16
4.4 Filling System	16
4.5 Concentration Control Dial Scale	16
4.6 Patents	16
4.7 Temperature Range	17
4.8 Flow Range	17
4.9 MRI Compatibility	17
5. FILLING AND DRAINING	18
5.1 Agent Specific (Keyed) Filling System	18
5.2 Screw Cap Filling System	22
6. INSTALLATION	24
6.1 Back Entry Mounting Models (Non-Interlock)	24
6.2 Back Entry Mounting Models (with Interlock)	25
6.3 Cagemount (23 mm) Taper Models	26
6.4 Penlon Off-line System (Mk.2 and Mk.3)	27
6.5 Selectatec Compatible Models (Non-Interlock)	28
6.6 Selectatec Compatible Models (with Interlock)	30
6.7 Drager 'Plug-In' Compatible	32
6.8 Pre-Use Checklist - All Models	33
7. PERFORMANCE CHARACTERISTICS	35
7.1 Performance Graphs	35
7.1.1 Halothane Models	36
7.1.2 Enflurane Models	37
7.1.3 Isoflurane Models	38
7.1.4 Sevoflurane Models	39
7.2 Temperature Compensation	39
7.3 Pressure Effects	39
7.3.1 Ambient Pressure	39

CONTENTS

7.3.2	Back Pressure	39
7.3.3	Intermittent Back Pressure	39
7.4	Summary of Performance Specifications	40
7.4.1	Factors Affecting Output Accuracy	40
7.4.2	Resistance to Gas Flow	41
7.5	Effect of IPPV on Output	41
7.6	Effect of Gas Composition on Output	41
7.7	Output when Control is at 0 (Zero)	41
7.8	Effect of Flush Valve Operation	41
8.	USER MAINTENANCE	
8.1	Servicing	42
8.2	Cleaning	43
8.3	Draining – Halothane Models	43
8.4	Checking Vaporizer Output	43
8.5	Training Course	44
8.6	Returning the Vaporizer for Service or Repair	44
9.	REFERENCES	45
10.	ORDERING INFORMATION	46

USER RESPONSIBILITY

This vaporizer has been built to conform with the specification and operating procedures stated in this manual and/or accompanying labels and notices when checked, assembled, operated, maintained and serviced in accordance with these instructions provided. To ensure the safety of this vaporizer it must be checked and serviced to at least the minimum standards laid out in this manual. A defective or suspected defective, product must not, under any circumstances be used.

The user must accept responsibility for any malfunction which results from non-compliance with the servicing requirements detailed in section 8.1.

Worn, broken, distorted, contaminated or missing components must be replaced immediately. Should such a repair become necessary it is recommended that a request for service advice is made to the nearest Penlon service centre.

This vaporizer and any of its constituent parts must be repaired only in accordance with written instructions issued by Penlon Ltd. and must not be altered or modified in any way without the written approval of Penlon Ltd. The user of this equipment shall have the responsibility for any malfunction which results from improper use, maintenance, repair, damage or alteration by anyone other than Penlon Ltd. or its appointed agents.

This vaporizer must only be supplied to, and used by, suitably qualified medical practitioners. Caution, USA and Canadian Federal Law restricts the sale and use of this device by or on the order of a physician.

Statements in this manual preceded by the following words are of special significance.

WARNING – means there is a possibility of personal injury to yourself or others.

CAUTION – means there is a possibility of damage to the instrument or other property.

NOTE – indicates points of particular interest for more efficient and convenient operation.

The reader must take particular notice of the warnings, cautions, and notes printed throughout the manual.

1. WARNINGS AND CAUTIONS

The following WARNINGS and CAUTIONS must be read and understood before using this vaporizer.

WARNINGS

General Information

1. THE USER MUST READ AND BE FAMILIAR WITH THE CONTENTS OF THIS INSTRUCTION MANUAL BEFORE USING THE VAPORIZER.

2. THE VAPORIZER IS DESIGNED FOR USE ONLY WITH THE SPECIFIC ANAESTHETIC AGENT NAMED ON THE FILLER BLOCK (AND FURTHER INDICATED BY COLOUR CODED LABELLING).

Misdosage may occur if the vaporizer is filled with the wrong drug.

AGENT SPECIFIC (KEYED) FILLER DEVICES ARE PROVIDED ON CERTAIN MODELS TO MEET NATIONAL AND INTERNATIONAL STANDARDS.

(See section 9 for Standards).

3. THE PHARMACOPOEIA NAME OF THE DRUG IS USED ON THE LABEL ACCORDING TO BP, USP, OR PH EUR. THE USER IS RESPONSIBLE FOR CONFIRMING THAT ANY TRADE NAME OF A DRUG IS EQUIVALENT TO THE REGISTERED NAME.

4. THIS VAPORIZER MUST NOT BE MODIFIED OR DISASSEMBLED BY AN UNAUTHORIZED PERSON. IT SHOULD BE REGULARLY SERVICED BY A PENLON-AUTHORIZED SERVICE AGENT, TRAINED TECHNICIAN OR ENGINEER AND BY NO OTHER PERSON.
(See Section 8.)

5. VAPORIZERS MAY MALFUNCTION IF EXPOSED TO EXCESSIVELY HIGH TEMPERATURES, E.G. BY STORAGE ABOVE A RADIATOR. THIS MAY AFFECT THE CALIBRATION.

MAXIMUM STORAGE TEMPERATURE: 50°C (122°F)
MINIMUM STORAGE TEMPERATURE: -20°C (-5°F)
OPERATING TEMPERATURE RANGE: 15 TO 35°C (58 TO 95°F)

Before use, function test a vaporizer that has been subjected to temperatures near the upper/lower limits given above.

Filling and Draining the Vaporizer

6. ANAESTHETIC DRUGS ARE POISONOUS AND THERE IS EVIDENCE THAT THERE IS A HEALTH HAZARD TO PERSONNEL DUE TO PROLONGED INHALATION OF TRACE CONCENTRATION IN THE ATMOSPHERE. CARE MUST BE TAKEN TO AVOID SPILLAGE OF ANAESTHETIC DRUGS WHEN FILLING OR DRAINING VAPORIZERS.

WARNINGS AND CAUTIONS

7. THE VAPORIZER CONTROL MUST BE IN THE 0 (ZERO) POSITION DURING THE FILLING OR DRAINING PROCESS.

Overfilling and/or spilling may occur if the control is not in the 0 (zero) position.

Provided the control is in the 0 (zero) position, gas may continue to be delivered from the anaesthetic machine to the patient during the filling procedure.

ALWAYS REIT AND TIGHTEN THE FILLER CAP ON SCREW CAP FILLER MODELS, AND ALWAYS TIGHTEN THE FILLER CONTROL ON AGENT SPECIFIC FILLER MODELS - DELIVERED CONCENTRATIONS ARE INACCURATE WHILE THE FILLER PORT IS OPEN.

IN ADDITION, ON AGENT SPECIFIC FILLER SYSTEMS, ALWAYS REIT THE KEY FILLER PLUG AND TIGHTEN THE CLAMP SCREW BEFORE USING THE VAPORIZER. THE VAPORIZER WILL LEAK IF THIS IS NOT DONE.

8. THE VAPORIZER MUST BE UPRIGHT DURING FILLING TO MINIMIZE THE RISK OF OVERFILLING.

9. DO NOT OVERFILL A VAPORIZER THAT HAS BEEN OVERFILLED. MUST BE WITHDRAWN FROM USE.

Contact the Service Department at Penlon Ltd. for advice.

10. ANAESTHETIC DRUGS MUST BE TREATED AS A PHARMACEUTICAL PRODUCT. LIQUID SHOULD NEVER BE DRAINED FROM A VAPORIZER INTO AN OPEN CONTAINER AND THEN REUSED. CONTAMINATION IS LIKELY. ALWAYS DISPOSE OF SUCH DRAINED LIQUID AS A HAZARDOUS CHEMICAL.

Before Using the Vaporizer

11. IF A VAPORIZER IS TRANSPORTED WHEN FILLED WITH LIQUID DRUG THE CONTROL MUST BE IN THE 0 (ZERO) POSITION DURING TRANSPORT AND A PERIOD OF AT LEAST TWO MINUTES IN A SECURED UPRIGHT POSITION MUST ELAPSE BEFORE CONNECTION TO AN ANAESTHETIC BREATHING SYSTEM.

Movement during transport can result in over-dosage unless time is allowed for drainage of liquid to the normal position.

IF A VAPORIZER HAS BEEN TRANSPORTED WITH THE CONTROL IN THE OPEN POSITION IT MUST BE FLUSHED AT 5 L/MIN FOR 2 MINUTES BEFORE CLINICAL USE ON A PATIENT.

12. THE VAPORIZER MUST NOT BE TIPPED OVER OR INVERTED.

IF THE VAPORIZER HAS BEEN TIPPED OVER OR INVERTED IT MUST BE SET TO MAXIMUM OUTPUT AND FLUSHED AT 5 L/MIN FOR 2 MINUTES BEFORE CLINICAL USE ON A PATIENT.

WARNINGS AND CAUTIONS

WARNINGS AND CAUTIONS

13. THE VAPORIZER MUST BE SECURELY FIXED AND IN AN UPRIGHT POSITION BEFORE CONNECTION TO A PATIENT.
- Using the Vaporizer
- There is a danger of overdose if sudden inadvertent movement occurs during use.
14. ANAESTHETIC MACHINE DESIGNS ARE CONSTANTLY EVOLVING, AND NEW MODELS MAY DIFFER DIMENSIONALLY FROM EXISTING EQUIPMENT. IT IS THE USER'S RESPONSIBILITY TO ENSURE THAT THE CONFIGURATION OF THE ANAESTHETIC MACHINE ALLOWS CORRECT INSTALLATION OF THE VAPORIZER.
15. BEFORE USE TEST ALL JOINTS FOR GAS TIGHTNESS, AND PERFORM BACK BAR FUNCTION TESTS AS DETAILED IN THE ANAESTHETIC MACHINE USER MANUAL.
16. CHECK THE LIQUID LEVEL FREQUENTLY WHEN USING THE VAPORIZER AND MAINTAIN THE LEVEL BETWEEN THE MIN. AND MAX. MARKS. THE VAPORIZER CONTROL MUST BE IN THE ZERO ('0') POSITION DURING THE FILLING PROCESS (See WARNING 7).
17. VAPORIZER OUTPUTS ARE SENSITIVE TO BAROMETRIC PRESSURE AND A CORRECTION FACTOR MAY BE NECESSARY WHEN ASSESSING THE OUTPUT USING AN ANALYSER, FOR EXAMPLE AT HIGH ALTITUDE. BAROMETRIC PRESSURE EFFECTS ARE NOT USUALLY OF CLINICAL IMPORTANCE. (See Section 7.3)
18. THE VAPORIZER IS A FLOW DIRECTION-SENSITIVE APPARATUS AND THE DIRECTION OF GAS FLOW TOWARDS THE PATIENT MUST BE AS INDICATED BY THE ARROWS ON THE TOP SURFACE.
- Reversal of flow may cause inaccuracies of delivered concentration.
19. THE VAPORIZER MUST NOT BE USED DOWNSTREAM OF THE COMMON GAS OUTLET.
20. AS STATED IN SECTION 2, THESE VAPORIZERS ARE OF RELATIVELY HIGH RESISTANCE AND MUST NOT BE INCORPORATED IN A BREATHING SYSTEM.
21. EXPIRED ANAESTHETIC VAPOURS SHOULD BE EXTRACTED FROM THE THEATRE BY AN ANAESTHETIC GAS SCAVENGING SYSTEM. (See section 9 for Standards.)
22. WHEN USING BACK ENTRY WITH INTERLOCK VAPORIZERS, ALL THE STATIONS ON THE BACK BAR MANIFOLD MUST BE OCCUPIED, TO MAINTAIN THE INTEGRITY OF THE INTERLOCK SYSTEM.
- CAUTIONS
1. THE SELECTATEC COMPATIBLE (NON-INTERLOCK) VAPORIZER IS DESIGNED TO FIT TYPE 3, 4, AND 7 MANIFOLDS AND WILL NOT INTERLOCK IF INSTALLED ON A UNIVERSAL MANIFOLD.
2. VAPORIZERS MANUFACTURED WITH BACK ENTRY CONNECTIONS ARE DESIGNED ONLY FOR ATTACHMENT TO THE PENLON VAPLOK VAPORIZER MOUNTING SYSTEM OR BACK ENTRY BACK BAR MANIFOLD.
3. ANAESTHETIC MACHINE AND WORKSTATION STANDARDS REQUIRE THAT MEANS BE PROVIDED TO ENSURE THAT GAS CANNOT PASS THROUGH MORE THAN ONE VAPORIZER CHAMBER.
- VAPORIZERS WITHOUT INTERLOCK DEVICES OR SYSTEMS MUST ONLY BE USED ON MACHINES WHICH ONLY HAVE ONE VAPORIZER MOUNTING STATION.

2. PURPOSE

The Sigma Elite vaporizer is designed for incorporation in the fresh gas supply system of continuous flow anaesthetic machines, directly connected between the flowmeter unit and the common gas outlet of the machine.

The vaporizer is unsuitable for use within a breathing system 'in circuit' because of the relatively high internal resistance.

Its purpose is the provision of accurate concentrations of anaesthetic drugs in the fresh gas supply, in accordance with the setting of the control dial, when the fresh gas supply flow is between 0.2 and 15 litres/min. Refer to section 7 – Performance Characteristics, which shows the extent of modifications to the control calibration.

Selectec Compatible Vaporizer with Interlock and Agent Specific (Keyed) Filler System

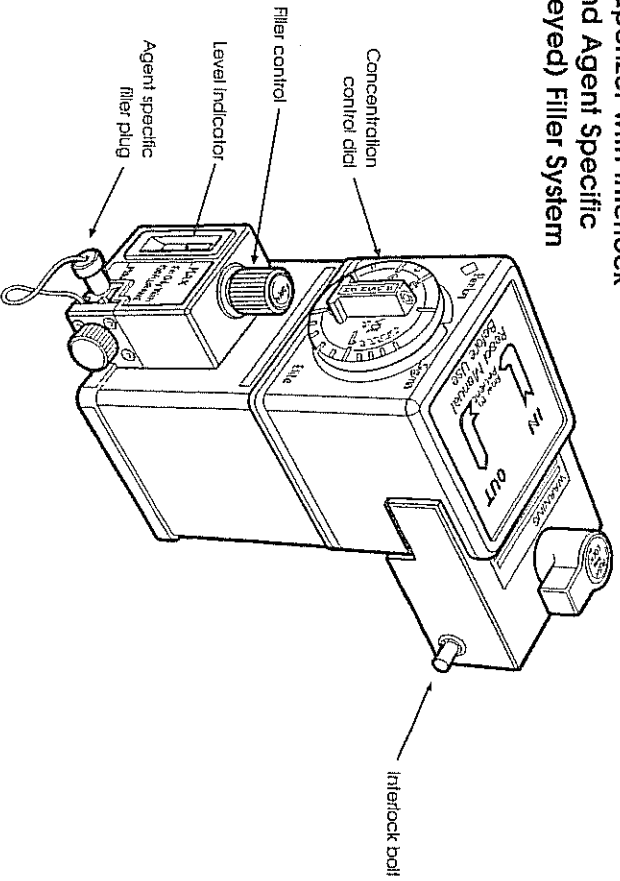

Selectec Compatible Vaporizer with Interlock and Screw Cap Filler System

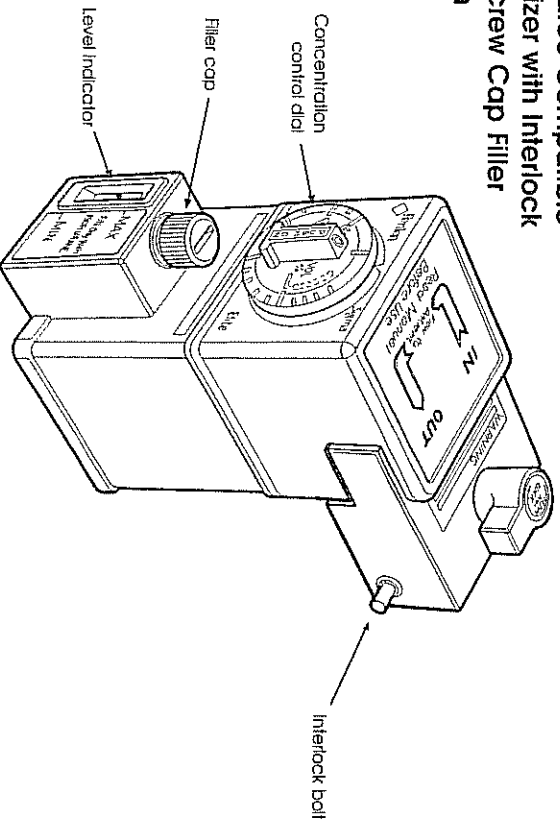

3. DESCRIPTION

3.1 Operating Principles

Each model is uniquely designed and tested for use only with the drug specified on the filler block.

The vaporizer contains a chamber, the base of which holds the anaesthetic agent in liquid form. A wick ensures that the upper part of the chamber is filled with the saturated vapour of the agent. The wick has a patented construction.

The concentration of saturated vapour is many times higher than those used clinically and the function of the concentration control is to proportion the flow of the carrier gas through a bypass passage and through the vapour chamber so that the desired dilution is produced.

In the zero position the bypass remains open but the vaporizing chamber is shut off completely from the gas flow to the patient.

A temperature-compensating valve is situated in the bypass, arranged to operate so that as the vapour pressure varies with temperature, the dilution ratio produced by the control valve is varied to compensate, and maintain a constant output concentration.

The vaporizer has a liquid level indicator, utilizing a floating ball and maximum and minimum level marks. Either an agent specific (also known as keyed filler), or screw cap filling and draining system may be fitted to suit the customer's requirements.

3.2 Controls

The vaporizer has a single, forward facing calibrated control to regulate the vapour concentration delivered.

The dial is locked at zero when not in use. To set a concentration level, push the dial assembly in and rotate anti-clockwise.

Align the required concentration graduation with the mark at the top of the bezel.

On returning the dial to zero, the dial assembly will automatically spring outwards into the locked 'off' position.

Interlock Models

When the vaporizer is mounted on the anaesthetic machine back bar with other interlock vaporizers, (Back Entry models, see additional WARNING below) initial operation of the concentration control dial activates the interlock system ensuring that only one of the vaporizers can be in use at any time.

The interlock deactivates as soon as the control dial is returned to the locked out zero position.

NOTE

The Sigma Elite Selectec Compatible Vaporizer with Interlock can be used on a Selectec Universal Series Manifold back bar in conjunction with some other types of

DESCRIPTION

Selectatec compatible vaporizers (i.e. from other manufacturers) fitted with the interlock function.

WARNING When using Back Entry with Interlock models, All the stations on the back bar manifold must be occupied to maintain the integrity of the interlock system.

4. SPECIFICATION

4.1 Physical Dimensions

	Width	Height	Depth
Cagemount	133	195	174
Back Entry	100	195	158
Back Entry with Interlock	120	195	186
Selectatec Compatible	100	217	204
Selectatec Compatible with Interlock	120	217	204
Drager 'plug in' Compatible	100	215	191

Dimensions given above are in millimetres

NOTE For Screw Cap Filler models depth, subtract 11 mm from the depth dimensions given above.

4.2 Weight

Approximate weight: 7.3 kg.

4.3 Capacity

Volume at MAX mark	300 ± 10
Volume at MIN mark	50 ± 10

Capacities given above are in millilitres

NOTE After draining, approximately 35 ± 10 ml of liquid is retained by the wick.

4. SPECIFICATION

4.4 Filling System

Agent Specific (Keyed)
To be used with corresponding agent specific filler adaptor, see section 10, Ordering Information.

Screw Top Filler

NOTE Not available in North America.

4.5 Control Dial Scale

The control dial is marked as follows:
From 0 to 2% vol, by intervals of 0.2% vol
From 2 to maximum, by intervals of 0.5% vol

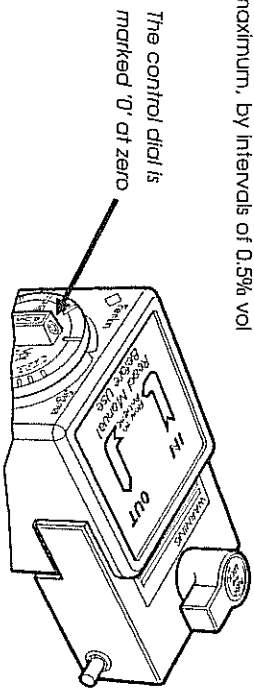

4.6 Patents

The Sigma Elite is protected by UK and foreign patents

The Selectric compatible mounting block is made by Penlon Ltd. under licence, UK patent no. 1385670.

The agent specific (keyed) filling system is made by Penlon Ltd. under licence, UK patent no. 1193241.

4. SPECIFICATION

4.7 Temperature Range

Operating Temperature Range
15 to 35°C (58 to 95°F)

Storage Temperature Range
-20 to 50°C (-5 to 122°F)

Storage In Transit (up to 7 days)
-40 to 60°C (-40 to 149°F)

Before use, function test a vaporizer that has been subjected to temperatures near the upper/lower limits given above.

4.8 Flow Range

Operating Flow Range
0.2 to 15 litres/min.

See section 7.4.1 for output accuracies at extreme conditions.

4.9 MRI Compatibility

The Sigma Elite Vaporizer has been tested for stability of output in close proximity to magnetic resonance imaging (MRI) machines, and it is recommended that the maximum field strength that the vaporizer is subjected to does not exceed 75 millitesla (750 Gauss).

5. FILLING AND DRAINING

5.1 Agent Specific (Keyed) Filling System

WARNING The vaporizer must be either secured to the anaesthetic machine or free standing on a level table so that in either case it is upright during the filling process. Overfilling may occur if the vaporizer is tipped during the filling process.

WARNING The vaporizer concentration control must be in the 0 (zero) position during the filling process. Provided this is done, gas may continue to be delivered from the anaesthetic machine to a patient during the filling process.

WARNING Check that the drug name on the vaporizer and the supply bottle are the same before commencing the filling process, and ensure that the bottle is fitted with a keyed collar.

Filling the Vaporizer

This system is manufactured in compliance with ISO 5360.

1. Check that the vaporizer concentration control (1) is in the 0 (zero) position as illustrated.

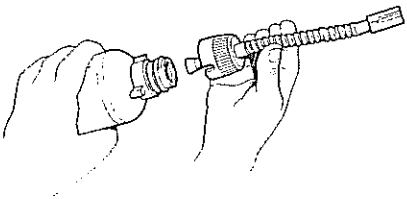
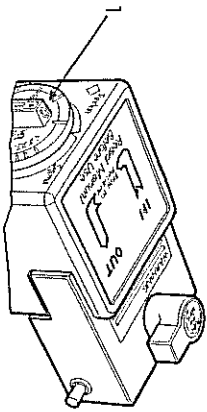

2. Attach the keyed filler adaptor to the bottle.

NOTE Penlon supply of complete range of agent specific filler adaptors, see section 10.

3. Tighten the adaptor to ensure an airtight joint, which must be maintained throughout the filling operation.

WARNING Failure to observe this instruction may result in overfilling.

4. Ensure that the filler control (2) is closed (fully clockwise). Loosen the clamp screw (3). Remove the plug (4).

5. Insert the keyed end of the bottle adaptor fully into the vaporizer receiver. Only the correct keyed-adaptor can enter the receiver. Tighten the clamp screw (3) to secure the adaptor.

6. Raise the bottle above the filler (see arrow on the illustration). Open the filler control (2) by turning fully anti-clockwise.

Allow the liquid to flow into the vaporizer until the upper mark is reached in the level indicator glass (5).

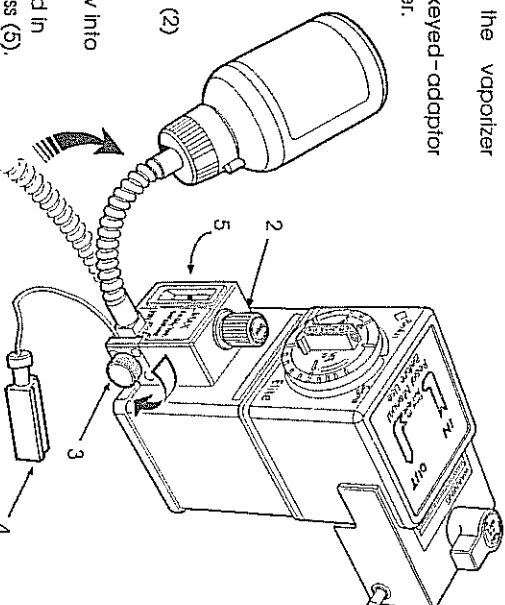
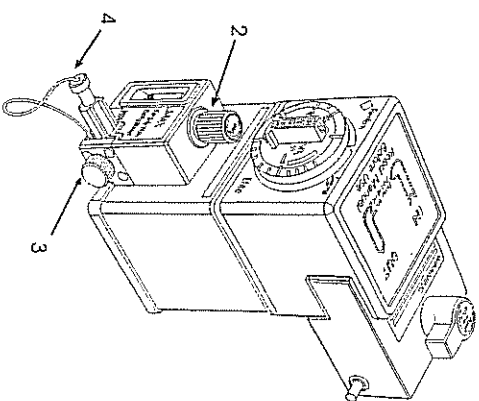

WARNING DO NOT OVERFILL. A vaporizer that has been overfilled must be withdrawn from use.

If the vaporizer has been inadvertently overfilled, excess liquid agent will spill from the drain hole in the keyed slot in the filler block. **DO NOT REUSE THIS AGENT.** Allow all the excess liquid to drain from the vaporizer before inserting the plug (4).

FILLING AND DRAINING

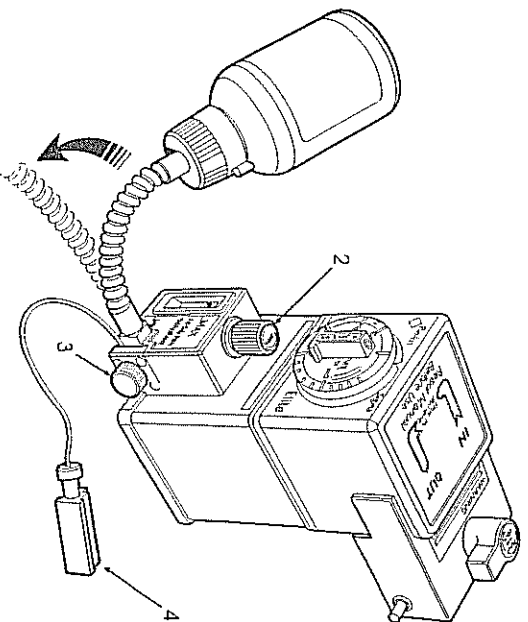

8. Close the filler control (2). Turn fully clockwise.
9. Lower the bottle below the level of the filler and allow the liquid in the bottle adaptor to flow back into the bottle. Loosen the clamp screw (3), remove the bottle adaptor from the receiver.

NOTE A small amount of liquid is always likely to spill when the bottle adaptor is removed from the receiver.

10. Insert the plug (4) and tighten the clamp screw (3).

WARNING For the vaporizer to function correctly it is important to insert the sealing plug fully, until it stops, before clamping it into position with the clamp screw after

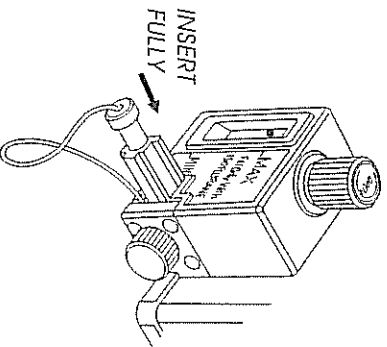

filling is completed. If this is not done, the possibility exists that agent may leak from the vaporizer or the vaporizer may not pressurize properly, giving reduced concentration output and gas flow to the patient.

FILLING AND DRAINING

Draining the Vaporizer

CAUTION To reduce atmospheric pollution in the operating room, it is recommended that vaporizer drainage should be performed in a fume cupboard or under an extractor hood.

WARNING The vaporizer must be either secured to the anaesthetic machine or free standing on a level table so that in either case it is upright during the draining process.

WARNING The vaporizer concentration control must be in the 0 (zero) position during the draining process.

1. Check that the vaporizer concentration control (1) is in the 0 (zero) position, as illustrated.
2. Follow steps 1 to 4 of the procedure for filling the vaporizer (see above), but keep the bottle below the filler.
3. Open the filler control (2) and allow the liquid to run into the bottle until the flow ceases.
4. Close the filler control (2), loosen the clamp screw (3), and reinsert the plug (4). Tighten the clamp screw (3).

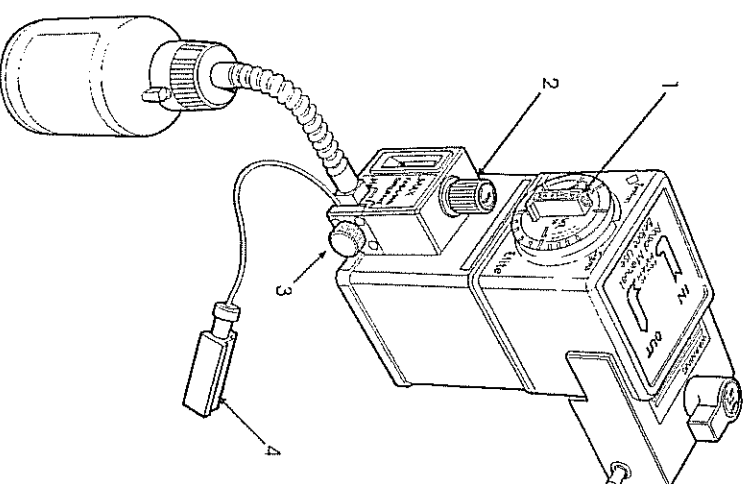

WARNING Anaesthetic drugs must be treated as a pharmaceutical product. Liquid should never be drained from a vaporizer into an open container and reused. Contamination is likely. Always dispose of such a drained liquid as a hazardous chemical.

FILLING AND DRAINING

5.2 Screw Cap Filling System

NOTE

Vaporizers with screw cap filler system are not available in North America.

liquid level occasionally. Stop filling when the upper mark in the level indicator is reached.

WARNING DO NOT OVERFILL. A vaporizer that has been overfilled must be withdrawn from use.

WARNING

The vaporizer must be either secured to the anaesthetic machine or free standing on a level table so that in either case it is upright during the filling process.

Overfilling may occur if the vaporizer is tipped during the filling process.

WARNING The vaporizer control must be in the 0 (zero) position during the filling process. Provided this is done, gas may continue to be delivered from the anaesthetic machine during the filling process.

WARNING Check the drug name on the vaporizer and the supply bottle before commencing the filling process.

Filling the Vaporizer

1. Check that the vaporizer concentration control (1) is in the 0 (zero) position as illustrated.
2. Unscrew the filler cap (2).
3. Remove the bottle cap and fill the vaporizer slowly and carefully, stopping to check the

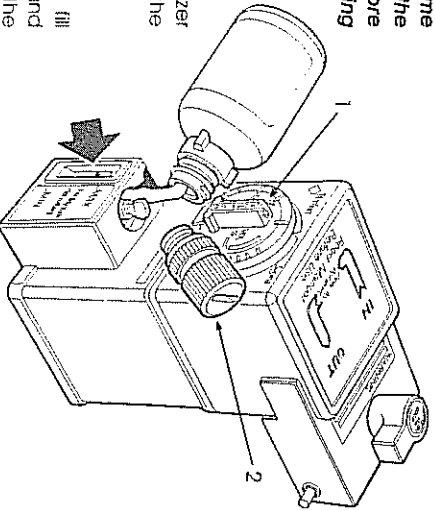

4. Replace the filler cap after a visual check that the white seal is in position on the cap. Tighten finger tight only. DO NOT use a wrench.

WARNING Do not operate the vaporizer if the filler cap is not secured in position.

Incorrect concentration may be delivered to the patient and pollution may result.

FILLING AND DRAINING

Draining the Vaporizer

CAUTION

To minimise atmospheric pollution in the operating room, perform vaporizer drainage in a fume cupboard or under an extractor hood.

WARNING

The vaporizer must be either secured to the anaesthetic machine or free standing on a level table so that in either case it is upright during the draining process.

WARNING The vaporizer concentration control must be in the 0 (zero) position during the draining process.

1. Check that the vaporizer concentration control (1) is in the 0 (zero) position, as illustrated.
2. Unscrew the filler cap (2). When inverted, a slot in this cap forms a means to undo the drain screw (3).
3. Place a bottle marked with the drug name on the vaporizer under the drain tube in the base of the filler block and undo the drain screw (3) at least three full turns.

WARNING Anaesthetic drugs must be treated as a pharmaceutical product. Liquid should never be drained from a vaporizer into an open container and reused. Contamination

- is likely. Always dispose of such drained liquid as a hazardous chemical.
4. Allow the liquid to run into the bottle until the flow ceases, and close the drain screw.

CAUTION Always close the drain screw firmly before replacing the filler cap on the vaporizer.

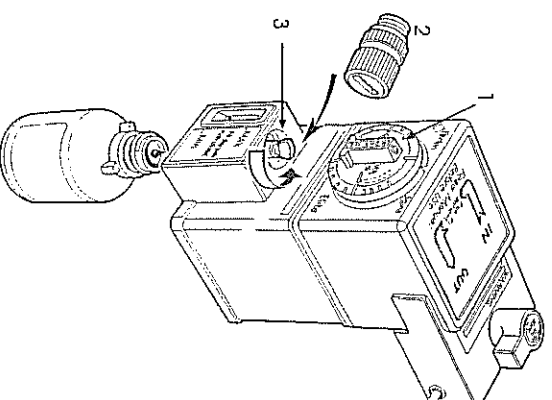

6. INSTALLATION

CAUTION Inlet and outlet connections are sealed for delivery transit. Ensure that these seals are removed from the vaporizer before installation on an anaesthetic machine.

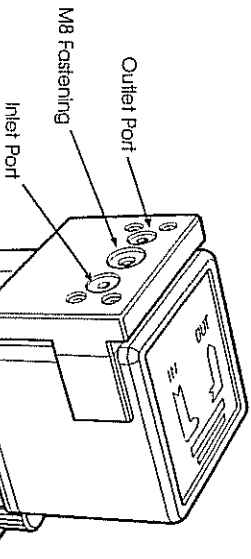

6.1 Back Entry Mounting Models

Vaporizers with back entry gas connections are available for fitting to the Penlon back entry mounting system as used on the Penlon Vaploak Vaporizer mounting system.

The vaporizer is attached using the single M8 mounting screw, the inlet and outlet connections being automatically made in the attachment process.

Pre-use Checks

Observe the WARNINGS below and carry out the check list procedure given in section 6.8.

WARNING Check the condition of the inlet and outlet

Back Entry

face-sealing O seals the back bar before mounting the vaporizer. Test the joints for gas tightness before using the machine. The blanking plate attached to the anaesthetic machine manifold must be in place on any empty vaporizer station.

INSTALLATION

6.2 Back Entry Vaporizer with Interlock

These vaporizers are designed for installation on the Penlon Back Entry Interlock Manifold (2, or 3 station).

The vaporizer is attached using the single M8 mounting screw, the inlet and outlet connections being automatically made in the attachment process.

WARNING All the stations of the backbar manifold must be occupied for the system to be operational. A blanking plate must be in place on any empty vaporizer station (See Ordering Information, section 4.0.)

Pre-use Checks
Observe the WARNINGS below and carry out the check list procedure given in section 6.8.

WARNING Check the condition of the face-sealing O-seals in the back bar before mounting the vaporizer. Test all joints for gas tightness before using

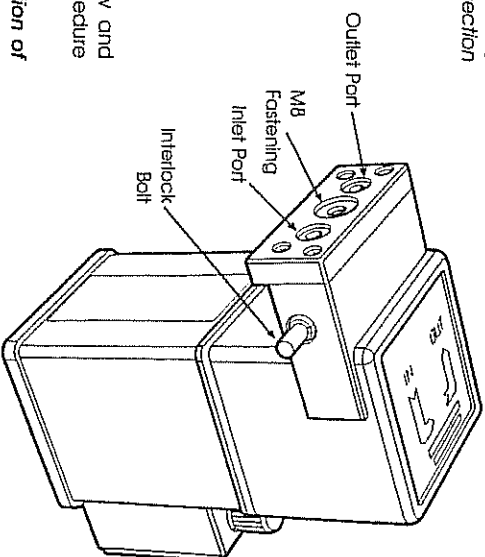

Back Entry with Interlock

the anaesthetic machine. Check that the interlock mechanisms of all the vaporizers on the manifold are working correctly, i.e. that only one vaporizer of a time can be turned on.

CAUTION Removal
The concentration control dials of all the vaporizers linked by the interlock system must be turned to zero before removing the vaporizer from the back bar.

INSTALLATION

6.3 Cagemount (23 mm) Taper Models

CAUTION

It is recommended that this type of vaporizer should only be used on machines with a single vaporizer mounting station.

Vaporizers fitted with cagemount tapers have the male taper (inlet port) on the left and the female taper on the right (viewing the front of the vaporizer). Two M6 studs with nuts, washers and a clamp plate are provided to fix the vaporizer to the back of the anaesthetic machine, or Modura claw assembly.

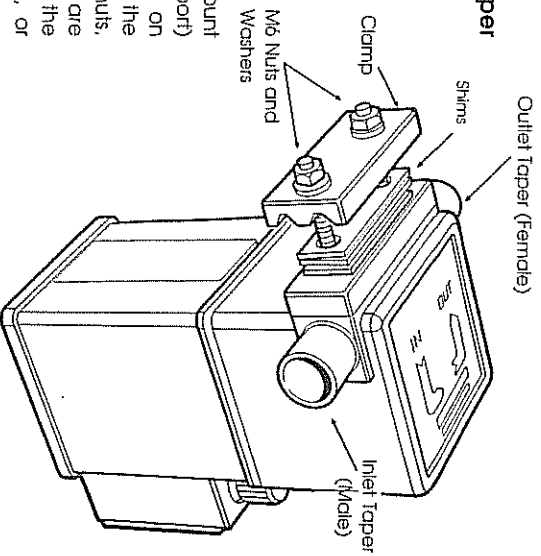

Cagemount Tapers

Taper Connectors

It is essential that the taper cone joints should be engaged axially and not sideways loaded. Shims are provided so that the distance from the back bar to the taper joint can be adjusted by adding or removing shims from the vaporizer.

The cone joints should then be lightly smeared with an oxygen compatible lubricant such as Formblin, the taper joints engaged by applying axial pressure, and the fixing nuts tightened.

Installation on Modura Rail

WARNING

The vaporizer must not be tipped or inverted during installation.

If the vaporizer has been tipped or inverted, it must be set to maximum and flushed at 5 L/min for two minutes. Check for stable output before clinical use.

1. Remove the M6 nuts and washers, the clamp plate and the shims from the vaporizer.

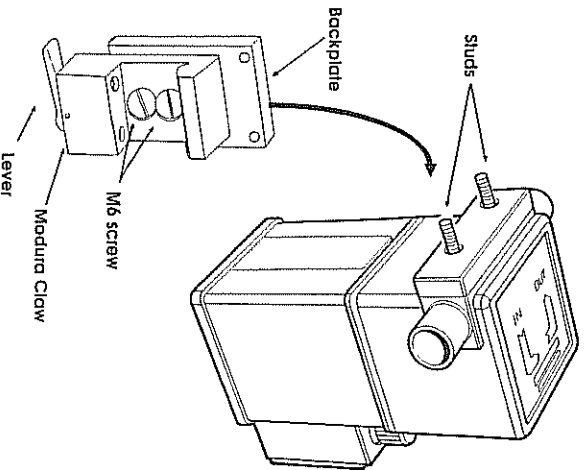

INSTALLATION

2. Fit the Modura claw to the backplate, using the two M6 screws.
3. Fit the Modura claw / backplate assembly to the studs on the rear of the vaporizer, and secure with the M6 nuts and washers.
4. Attach the vaporizer to the Modura rail on the anaesthetic machine and secure in place by moving the lever into its 'locked on' position.

6.4 Penlon Off-line Mounting System (Mk.2 and Mk. 3)

CAUTION

Inlet and outlet connections are sealed for delivery transit. Ensure that these seals are removed from the vaporizer before installation on an anaesthetic machine.

Pre-use Checks

Observe the WARNINGS below and carry out the check list procedure given in section 6.8.

WARNING *Test the joints for gas tightness before using the machine.*

A vaporizer with cagemount tapers may be fitted with a Penlon clip, Part No. 58090, in place of the back bar clamp. The vaporizer may then be fitted to a Penlon off-line block, (use Penlon Part No. 52280 for the Mk.2 and Part No. 52270 for the Mk.3 system).

The flexible hoses attached to the block are connected to the inlet and outlet of the vaporizer.

It is recommended that detachable cagemount connectors are retained with safety clip, catalogue number 52275, to prevent inadvertent disconnection.

WARNING *Test the joints for gas tightness before using the machine.*

INSTALLATION

6.5 Selecttec Compatible Models – Non-Interlock

Vaporizers with a Selecttec compatible back bar fitting are available for fitment to Selecttec type back bar manifolds.

CAUTION

To comply with anaesthetic machine (workstation) standards, this type of vaporizer must only be used on machines with one vaporizer mounting station.

WARNING

Anaesthetic machine designs are constantly evolving, and new models may differ dimensionally from existing equipment.

It is the user's responsibility to ensure that the configuration of the anaesthetic machine allows correct installation of the vaporizer.

There must be sufficient clearance between the Selecttec manifold and the rear panelling/frame of the machine to allow the vaporizer connector block to seal correctly on the manifold.

To install the vaporizer, carefully offer the vaporizer up to the manifold on the machine, ensuring that:

(a) The gas connection ports are aligned with the valve capsule on the manifold. (The capsule is referred to as the valve 'cartridge' in some user literature.)

(b) The button plate is aligned with the location button on the manifold. (The location button is referred to as the 'rest pad' in some user literature.)

Carefully lower the vaporizer onto the manifold, and then lock into position by pushing the locking lever downwards and rotating clockwise through 90°.

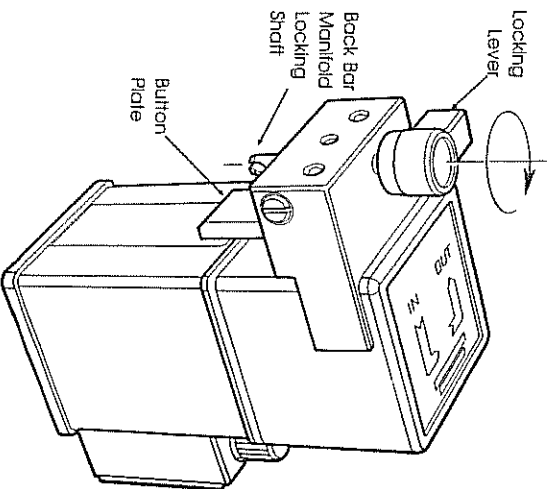

Selecttec
Compatible

INSTALLATION

WARNING

The Selecttec compatible vaporizer is designed to fit the Type 3 manifold. Sigma Elite vaporizers will not interlock if installed on a Universal manifold.

CAUTION

To prevent damage to the locking shaft, recheck that the gas ports and button plate on the vaporizer are correctly engaged with the valve capsules/cartridges and button/rest pad on the manifold before tightening the locking lever.

Pre-use Checks

Observe the WARNINGS below and carry out the check list procedure given in section 6.8.

WARNING

Test all joints for gas tightness before using the anaesthetic machine.

The locking lever **MUST** be in the locked position before the vaporizer is operated.

Removal

To remove the vaporizer, rotate the locking lever 90° anti-clockwise and carefully lift vertically until clear of the back bar manifold.

INSTALLATION

6.6 Selectatec Compatible Models - with Interlock

These vaporizers are designed for installation on a Selectatec Universal Series Manifold back bar and can also be used on the Type 3 Manifold.

NOTE When installing two vaporizers only on a three station manifold, the centre station must be occupied by one of the vaporizers.

WARNING Anaesthetic machine designs are constantly evolving, and new models may differ dimensionally from existing equipment.

If it is the user's responsibility to ensure that the configuration of the anaesthetic machine allows correct installation of the vaporizer.

There must be sufficient clearance between the Selectatec manifold and the rear paneling/frame of the machine to allow the vaporizer connector block to seal correctly on the manifold.

To install the vaporizer, carefully offer the vaporizer up to the manifold, ensuring that:

(a) The gas connection ports are aligned with the valve capsule on the manifold. (The capsule is referred to as the valve 'cartridge' in some user literature)

(b) The button plate is aligned with the location button on the manifold. (The location button is referred to as the 'rest pad' in some user literature).

Carefully lower the vaporizer onto the manifold, and then lock into position by pushing the locking lever downwards and rotating clockwise through 90°.

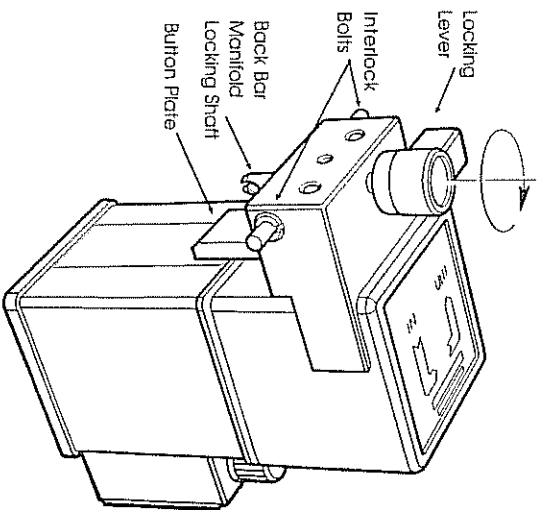

Selectatec
Compatible
with Interlock

INSTALLATION

CAUTION To prevent damage to the locking shaft, recheck that the gas ports and button plate on the vaporizer are correctly engaged with the valve capsules/cartridges and button/rest pad on the vaporizer before tightening the locking lever.

Pre-use Checks

Observe the **WARNING** below and carry out the check list procedure given in section 6.8.

WARNING Test all joints for gas tightness before using the anaesthetic machine.

The locking lever **MUST** be in the locked position before the vaporizer is operated.

Removal

NOTE The concentration control dials of all the vaporizers linked by the interlock system must be turned to zero before removing the vaporizer from the manifold.

To remove the vaporizer, rotate the locking lever 90° anti-clockwise and carefully lift the unit vertically until clear of the back bar.

INSTALLATION

6.7 Dräger 'Plug-in' Compatible (non-interlock)

CAUTION To comply with anaesthetic machine (workstation) standards, this type of vaporizer must only be used on machines with one vaporizer mounting station.

To install, carefully offer up the vaporizer to the back bar manifold ensuring that the gas connection ports are aligned with the valves on the manifold.

WARNING To prevent damage to the locking shaft, and to ensure that the gas connection ports are correctly engaged, check that the vaporizer is firmly positioned on the manifold before tightening the locking lever. The locking lever **MUST** be in the locked position before the vaporizer is used.

Removing the Vaporizer
Rotate the locking lever fully anticlockwise and carefully lift the vaporizer from the manifold.

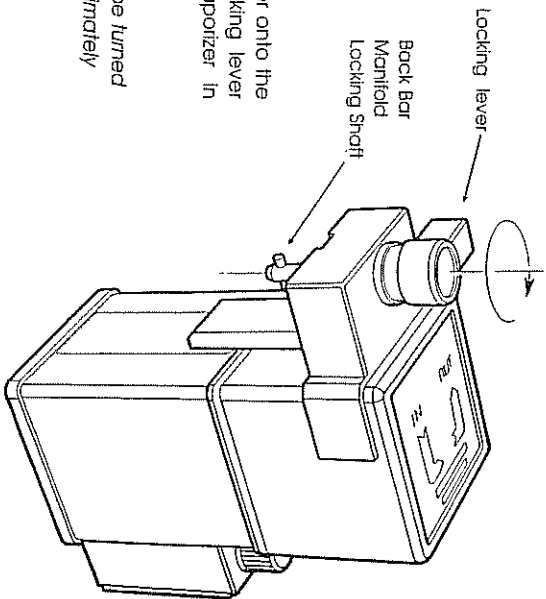

NOTE The lever must be turned through approximately 100°.

Carefully lower the vaporizer onto the manifold and turn the locking lever clockwise to lock the vaporizer in position.

Pre-Use Checks

Observe the WARNINGS below and carry out the check list procedure given in section 6.8.

INSTALLATION

6.8 Pre-Use Check List

In addition to the pre-use warnings listed for different models in sections 6.1 to 6.7, the following check list procedure must be carried out on ALL vaporizers before use.

1. Check that the vaporizer concentration control is in the 0 (zero) position.
2. Check that the liquid level is between the MIN and MAX marks on the filler block.
3. On agent specific filler models, check that the filler plug is fully inserted and that the clamp screw is fully tightened. Check also that the filler control is securely closed.
4. On screw cap filler models, check that the filler cap is securely closed.
5. Perform a back bar manifold leak test as detailed in the relevant anaesthetic machine user instruction manual.

WARNING Anaesthetic machine designs are constantly evolving, and new models may differ dimensionally from existing equipment. It is the user's responsibility to ensure that the configuration of the anaesthetic machine allows correct installation of the vaporizer.

7. PERFORMANCE CHARACTERISTICS

PERFORMANCE CHARACTERISTICS

NOTE
Concentration output figures quoted and shown graphically in this section were compiled from average test results from a number of vaporizers. The output from individual units may vary from these average figures.

7.1 Performance Graphs 7.1.1 Halothane Models

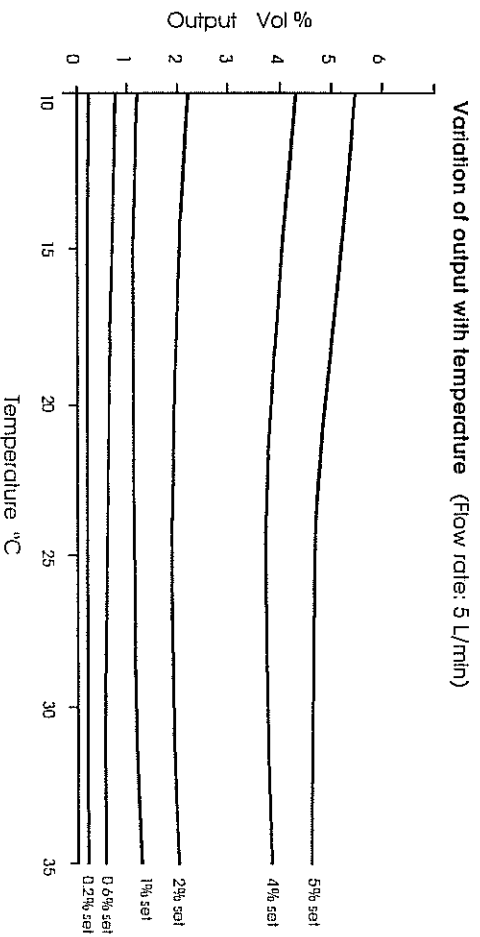
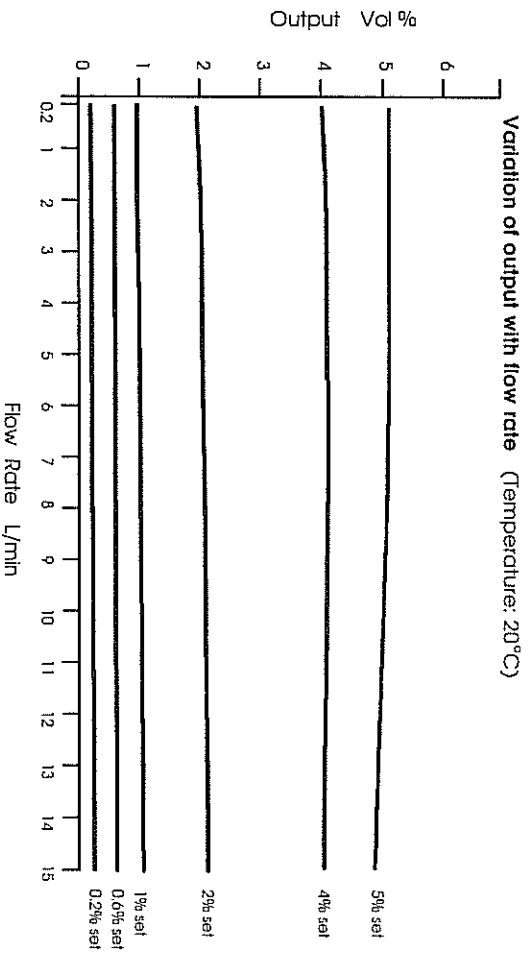

PERFORMANCE CHARACTERISTICS

7.1.2 Enflurane Models

Variation of output with flow rate (Temperature: 20°C)

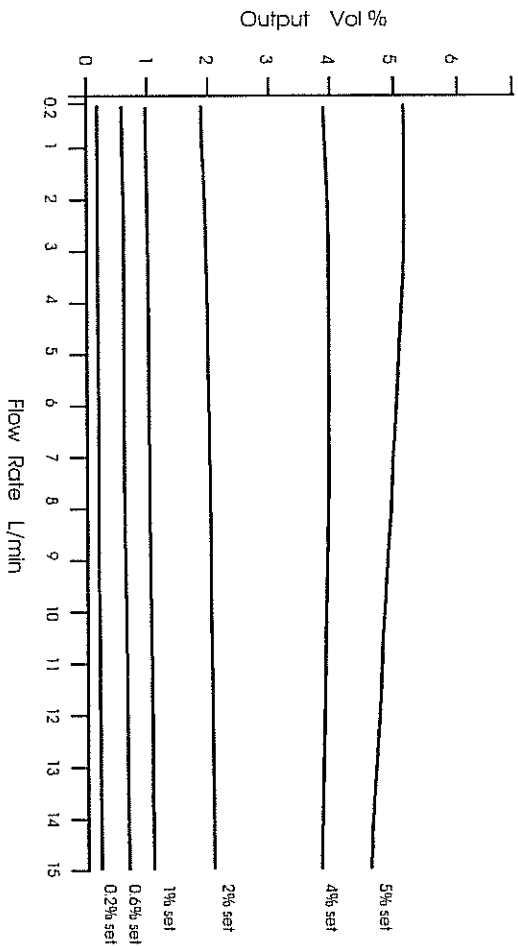

Variation of output with temperature (Flow rate: 5 L/min)

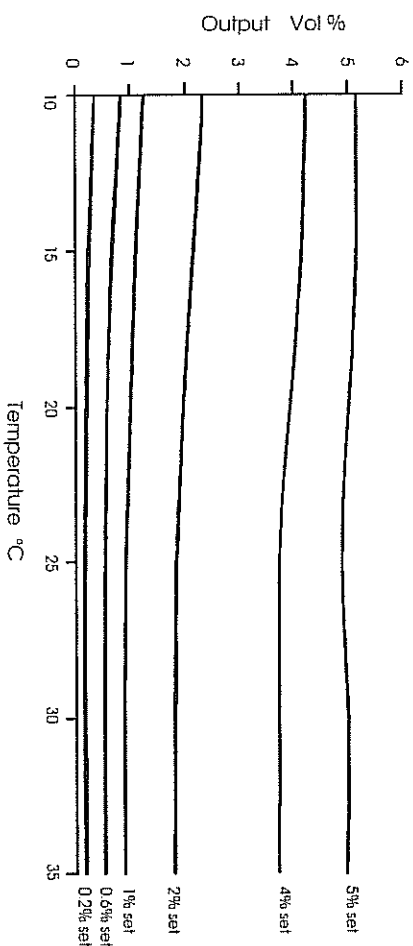

PERFORMANCE CHARACTERISTICS

7.1.3 Isoflurane Models

Variation of output with flow rate (Temperature: 20°C)

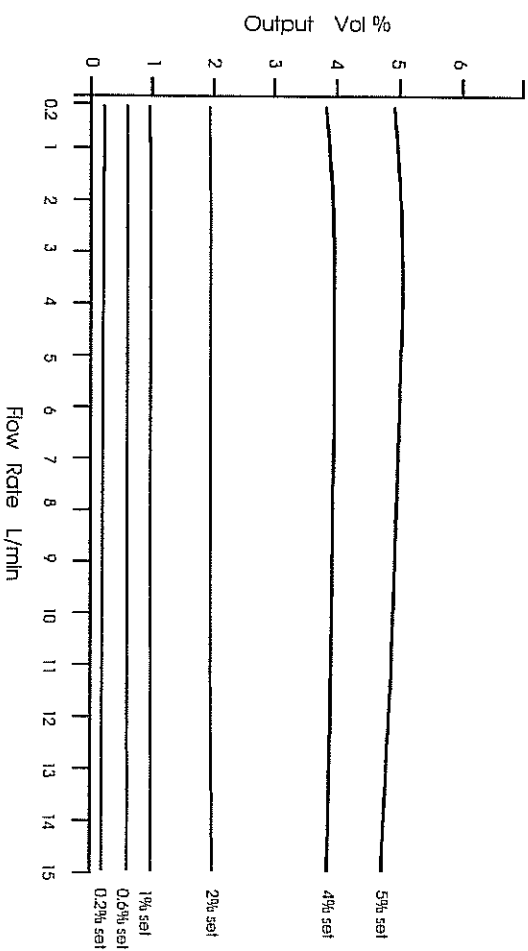

Variation of output with temperature (Flow rate: 5 L/min)

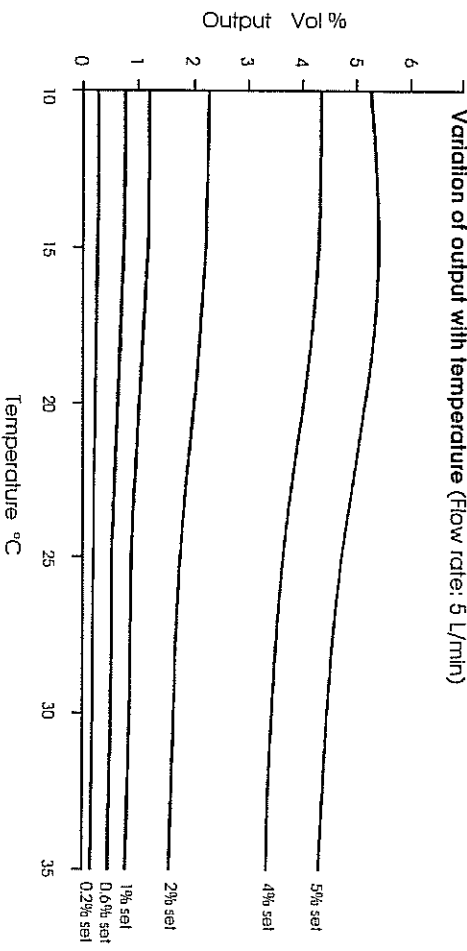

PERFORMANCE CHARACTERISTICS

7.1.4 Sevoflurane Models

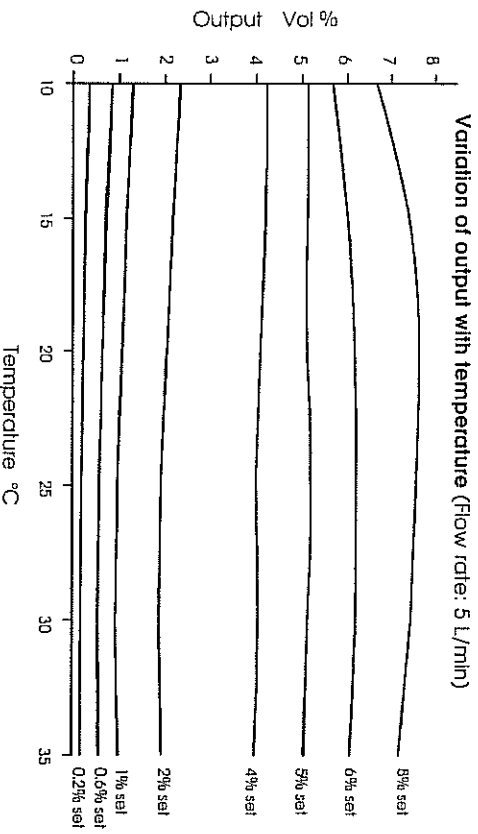
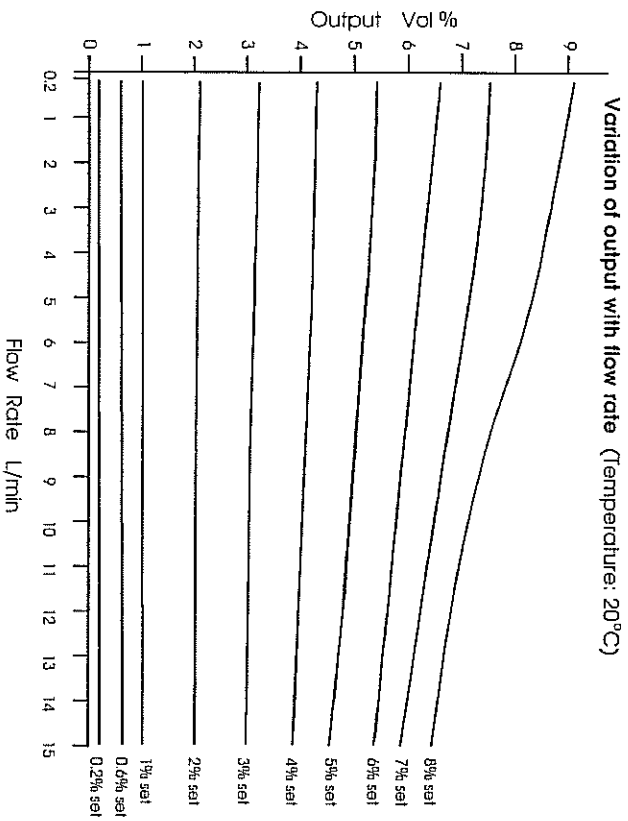

PERFORMANCE CHARACTERISTICS

7.2 Temperature Compensation

Temperature compensation is provided by the operation of a variable resistance valve in the bypass passage. The design provides compensation for the full range of user temperatures. If the vaporizer is used in extreme temperatures, (outside those shown in section 4.7) outputs may be lower or higher than indicated by the concentration control.

NOTE

The temperature compensator reacts relatively slowly to room temperature changes. If the temperature around a vaporizer is suddenly changed (e.g. by wheeling an anaesthetic machine from a cool store into theatre), 1 to 2 hours minimum should be allowed for it to equilibrate with the ambient temperature before use.

7.3 Pressure Effects

7.3.1 Ambient Pressure

Ambient pressure effects are not normally of clinical significance but the following rules apply:

The control is graduated in units of %vol at 101.3 kPa (14.7 psi). At any other pressure the true output will be modified according to the equation:

$$C = 5\% \times \frac{101.3}{P}$$

P is absolute pressure in kPa.

C is delivered concentration %vol,
5% is the set value.

Changes in barometric pressure can be ignored clinically because they affect the vaporization in the vaporizer and the absorption of vapour through the lungs in the same way. They must be corrected for when checking outputs with an analyser.

NOTE

Some analysers include automatic barometric pressure correction. Check the instructions provided with the analyser.

7.3.2 Back Pressure

Back pressures imposed on the vaporizer by ventilators or other parts of the anaesthetic apparatus are usually relatively small, but certain ventilators can impose steady back pressures of 10 to 15 kPa (100 to 150 cmH₂O) which will produce a reduction of the output concentration.

7.3.3 Intermittent Back Pressure

Intermittent back pressure imposed on the vaporizer by a ventilator may result in some change in output. The effect is greatest at low settings of the control and low flow rates, and the Sigma Elite vaporizer is designed to comply with the tests laid down in various Standards in this respect (see section 9).

PERFORMANCE CHARACTERISTICS

7.4 Summary of Performance Specifications

7.4.1. Factors Affecting Output Accuracy

The following conditions may affect the accuracy of the vaporizer. Column A in the table shown below lists the design limits for normal use. Column B lists extreme conditions, and, if necessary, indicates when the vaporizer may be used reliably only after reference to the sections of the manual indicated.

Under the conditions listed in column A, the maximum deviation from the set concentration is $\pm 20\%$ of scale reading or $\pm 5\%$ of the maximum production, whichever is greater.

	A (Normal Use)	B (Extreme Conditions)
Gas composition	O ₂ , Air + N ₂ O mixture	Helium mixture, section 7.6
Liquid level	Liquid visible between MIN and MAX marks	See section 1, WARNING 16.
Temperature	15 to 35°C	10 to 15°C and 35 to 40°C, section 7.2
Flow Rate	0.5 to 10 L/min	0.2 to 0.5 and 10 to 15 L/min Accuracy not affected.
Altitude	Sea level to 2440 m (8000 ft)	Very high altitudes* or hypobaric conditions*
Intermittent back pressure	As Standards listed in section 9 (c).	
Movement	Do not agitate during use	See section 1, WARNINGS 11/13
Inversion or flipping	Do not tip or invert	Flush for 2 minutes at 5 L/min before use. See section 1, WARNING 12

*The combination of high altitude and high temperature may lead to loss of accuracy.

PERFORMANCE CHARACTERISTICS

7.4.2. Resistance to Gas Flow

Resistance to gas flow measured at 22°C (72°F) and 101.3 kPa (1013 mbar, or 14.7 psi), control position 0 (zero):

Flow Rate using Air (L/min)	Resistance (cm H ₂ O)
1	2.8
2	5.0
4	10.4
8	22.4

Resistance varies from these nominal values at other control positions, with changes with temperature, and for each agent (e.g. the nominal value for Sevoflurane at 4 L/min is 12 cmH₂O).

7.5 Effect of IPPV on Output

For 2 kPa IPPV at a flow rate of 2 L/min, output concentration will decrease by up to 20%.

For 5 kPa IPPV at a flow rate of 8 L/min, output concentration will decrease by up to 10%.

7.6 Effect of Gas Composition On Output

The vaporizer is calibrated with pure oxygen and the scale is therefore most accurate with this gas. The effect of other gases normally used in anaesthesia is as follows:

Nitrous oxide

Nitrous oxide, added to oxygen, will produce a decrease in output

below the scale value. At a concentration of 70% nitrous oxide output may decrease by up to 15%.

Carbon dioxide

Carbon dioxide is not usually added in high concentrations and is usually limited to 5%. At this concentration the effect on vaporizer output is negligible.

Air

Air will reduce the output of the vaporizer below the scale values by a maximum of 5%.

Helium

Vaporizers will give low results on helium-enriched mixtures, and the use of an analyser is recommended if accurate concentrations are required when using this gas.

7.7 Output when Control is at 0 (zero)

Output vapour concentration when the control is at 0 (zero) is less than 0.03% vol., when tested in accordance with ASTM F1169-88.

7.8 Effect of Flush Valve Operation

Operating the flush valve on the anaesthetic machine will effect output concentration by less than $\pm 5\%$.

Note that the vaporizer was tested to ISO CD8835.1 (Tests 67.10 and 67.11).

8. USER MAINTENANCE

USER MAINTENANCE

- CAUTION** Do not attempt to dismantle the vaporizer or make any adjustment to it which is outside the scope of the following instructions.

8.1 Servicing

- NOTE** A label is fixed across the vaporizer body and top cover, bearing the words:
- GENUINE PART.
LABEL TAMPERING
VOIDS WARRANTY.**

When the top cover of the vaporizer is removed this label will be damaged beyond repair as permanent evidence of unauthorised servicing, repair or modification. If this label is missing, do not use the vaporizer until it has been serviced (see below).

NOTE

The user must accept responsibility for any malfunction which results from non-compliance with the above requirements.

The Sigma Elite must only be serviced at an authorized service centre or by Penlon-trained technicians in accordance with the following procedure.

- (o) The calibration should be checked periodically under controlled conditions (section 8.4) and leak tests performed. Use the service record book supplied with the vaporizer to record the measured values.

- (b) Successive sets of figures should be compared to determine if performance is deteriorating. Should deterioration be detected, a service should be carried out to restore normal operation.
- (c) A major overhaul must be performed every 5 years to maintain performance within the specification.
- (d) The Selectatec compatible vaporizer locking system should be inspected during the vaporizer calibration test, and if damage to the locking shaft is suspected, the device must be referred to a Penlon certified engineer.

- (e) Interlock system vaporizers – function test the interlock system during the vaporizer calibration test.

8.2 Cleaning and Sterilization

The exterior of the vaporizer should be kept clean and dust free with a dry cloth, or, if necessary use proprietary cold sterilized wipes.

Do not use water or other liquids.

8.4 Checking Vaporizer Output

The output of the vaporizer should be checked periodically, either:

- (i) as part of the Penlon Service Contract (UK only)
- (ii) by a Penlon certified engineer
- (iii) by a suitably qualified hospital technician if agent analysis apparatus is available.
- To be comparable with the master calibration, such tests must conform to the following.

8.3 Draining – Halothane Models

Because halothane contains a stabilizing agent which is only slightly volatile (0.1% thymol), the vaporizer chamber should be drained periodically of all liquid and the liquid disposed of as a hazardous chemical. If the vaporizer is not drained periodically, the stabilizing agent will accumulate in the vaporizer and eventually cause low output.

There is some evidence that high levels of accumulated thymol can have clinically undesirable effects on the patient. (Ref. Rosenberg – Allia: Anaesthesia, 1984: 38:581–583).

If the vaporizer is in regular use this draining operation should be performed weekly.

WARNING Prolonged exposure of anaesthetic agents to light and gases may lead to a brown or yellow colouration

Discoloured liquid and/or liquid drained from a vaporizer must not be used and should be disposed of as a hazardous chemical.

- (a) The carrier gas should be oxygen.

- (b) The vaporizer must be filled, and fixed upright and stationary, at a temperature between 18 and 22°C (64 and 72°F) for at least 2 hours.

- (c) A mixing chamber must be attached to the outlet of the vaporizer to ensure that a homogeneous mixture is sampled.

- (d) This is particularly necessary at low gas flow rates.

- (e) The sampling system must be of non-absorbent material such as nylon. (Rubber, etc., absorbs vapour to a substantial extent.)

- (f) Flow rates, etc., must lie within the range covered by the master calibration charts.

- (g) The analysis apparatus must be of an approved type, e.g. a Riken refractometer.

USER MAINTENANCE

However, if the calibration check is undertaken by a hospital technician, it is permissible to use a commercially available agent analyser, but only if:

- i) the analyser is calibrated to the manufacturer's specification and schedule
- ii) output failures are confirmed by a Penlon certified engineer using a refractometer.

- g) Output values should be recorded in the vaporizer service record book. The vaporizer serial number and any comments must be written at the foot of each page.

At the completion of the first Five Year Overhaul, a copy of pages 11 to 15 should be faxed to Penlon Limited (Fax No: 44 1235 547031).

At the completion of the second Five Year Overhaul, a copy of pages 16 to 20 should be faxed to Penlon Limited (Fax No: 44 1235 547031).

8.5 Training Course

A training course is available to engineers and hospital staff who wish to carry out routine maintenance on vaporizers. The course covers:

- Leak testing
- Replacement of seats
- Internal maintenance
- Replacement of major sub-assemblies
- Regulation of output

A manual describing this work is available to personnel who have undergone this course.

8.6 Returning the Vaporizer for Service or Repair

The vaporizer must be drained and allowed to dry out before packing.

Always use the original packaging, to prevent damage during transit.

On agent specific (keyed) filler vaporizers, loosen the clamp screw and withdraw the plug (see page 19, operation 4). This will prevent possible damage to the filler block secti-

9. REFERENCES

Standards

The Sigma Elite vaporizer has been designed in accordance with the following Standards:

- (a) General
 - BS 4272, Part 3 1989, Sections 13, 14
 - ISO 5358, 1992, Sections 12/13/14
 - ASTM F1161, 1988, Section 12
 - CSA CAN3 Z168.3 M84, Section 12
 - DIN 13252, Sections 4.9 – 4.13, and 5.9 – 5.13

- (b) Agent Specific (Keyed) Filling System
 - CSA CAN3Z168.4 M83
 - DIN 13252, Sections 4.11 and 5.11
 - ISO 5360, 1993

Trademarks

Selectrac is a BOC trademark.
Moduro is an S&W trademark.

10. ORDERING INFORMATION

A wide range of Halothane, Enflurane, Isoflurane, and Sevoflurane vaporizers are available.

Various combinations of agent, concentration output, and connector block type, are available with either agent specific filler, or screw cap filler systems.

NOTE Vaporizers with screw cap filler system are not available in North America.

Contact Customer Service at Penton Ltd (Tel: 01235 547001, fax: 01235 547021) for the latest information.

Accessories

52275 Safety clip for cagemount
tapers (Off-line system only)

57902 Blanking plate for Back Entry
with Interlock vaporizer
station

53450 Agent Specific (Keyed) filler
adaptor for halothane
bottles (ICI, May and
Baker, and Hoechst)

53451 Agent Specific (Keyed) filler
adaptor for halothane
bottles (Ohio, and Ayerst)

53452 Agent Specific (Keyed) filler
adaptor for enflurane
bottles

53453 Agent Specific (Keyed) filler
adaptor for isoflurane
bottles

53454 Agent Specific (Keyed) filler
adaptor for sevoflurane
bottles