

Paragon

Draft Copy
July 2005

No update will be given

AV-S Ventilator

Remote Display Module and Interface

for use with A200SP Absorber

User Manual



IMPORTANT

Servicing and Repairs

In order to ensure the full operational life of this ventilator, servicing by an engineer trained by the manufacturer should be undertaken periodically.

The ventilator must be serviced to the following schedule:

- (a) Six monthly service - inspection and function testing.
- (b) Annual service.
- (c) Five year major service including battery replacement.

Details of these operations are given in the Service Manual for the AV-S, available only for engineers trained by the manufacturer.

For any enquiry regarding the servicing or repair of this product, contact Paragon Service.

Paragon Service
W. Bennet Sreet
Saline
MI 48176

Always give as much of the following information as possible:

- 1. Type of equipment
- 2. Product name
- 3. Serial number
- 4. Approximate date of purchase
- 5. Apparent fault

FOREWORD

This manual has been produced to provide authorised personnel with information on the function, routine performance and maintenance checks applicable to the AV-S Anaesthesia Ventilator.

Information contained in this manual is correct at the date of publication.

The policy of the manufacturer is one of continued improvement to its products.

Because of this policy, the manufacturer reserves the right to make any changes which may affect instructions in this manual, without giving prior notice.

Personnel must make themselves familiar with the contents of this manual and the machine's function before using the apparatus.

THE IMPORTANCE OF PATIENT MONITORING

WARNING

Anaesthetic systems have the capability to deliver mixtures of gases and vapours to the patient which could cause injury or death unless controlled by a qualified anaesthetist.

There can be considerable variation in the effect of anaesthetic drugs on individual patients so that the setting and observation of control levels on the anaesthesia systems does not in itself ensure total patient safety.

Anaesthesia system monitors and patient monitors are very desirable aids for the anaesthetist but are not true clinical monitors as the condition of the patient is also dependent on his respiration and the functioning of his cardio-vascular system.

IT IS ESSENTIAL THAT THESE ELEMENTS ARE MONITORED FREQUENTLY AND REGULARLY AND THAT ANY OBSERVATIONS ARE GIVEN PRECEDENCE OVER MACHINE CONTROL PARAMETERS IN JUDGING THE STATE OF A CLINICAL PROCEDURE.

CONTENTS

	Page No.
USER RESPONSIBILITY	1
1. WARNINGS AND CAUTIONS	2
2. PURPOSE	7
3. DESCRIPTION	
3.1 General	8
3.2 Ventilation Cycle	10
3.3 Pneumatic System	14
3.3.1 System Operation	14
3.4 Electrical System	15
3.5 Control Panel	16
3.5.1 Touchscreen Operation and Navigator wheel / push-button	16
3.5.2 User Adjustable Parameters	17
3.5.3 Operational capability	17
3.5.4 Output Compensation Functions	18
3.6 Interface with PrimaSP2 and A200SP	19
3.7 Ventilation Modes	20
3.7.1 Standby Mode	20
3.7.2 Volume Mode	21
3.7.3 Pressure Mode	22
3.7.4 Spontaneous Mode	23
3.7.5 PSV (Pressure Supported Ventilation)	24
3.7.6 PEEP (Positive End Expiratory Pressure)	25
3.8 On-screen Menus	26
3.9 Spirometry	27
3.10 Display Waveforms	27
3.11 Alarms	28
3.12 Oxygen Monitor	29
3.12.1 System Operation	29
3.12.2 The MOX-3 Oxygen Sensor	29
3.12.3 Menus	30
3.12.4 Display	31
3.12.5 Alarms	31
3.12.6 Alarm Mute.	31
4. SPECIFICATION	32
Ventilator	32
Oxygen Monitor	35
5. PRE-OPERATION PROCEDURES	
5.1 Ventilator Set-up	37
5.1.1 Mounting the Ventilator	37

CONTENTS

5.1.2	Electrical Power Connections	37
5.1.3	Ventilator Gas Supply	37
5.1.4	Breathing System Schematic	37
5.1.5	Bellows Drive Gas	39
5.1.6	Anaesthetic Gas Scavenging System	41
5.1.7	Printer	41
5.1.8	Breathing System	41
5.1.9	Spirometer Connections	42
5.1.10	Pressure Monitor Connections	44
5.1.11	Bellows Assembly	45
5.2	Pre-use Checklists	46
5.2.1	Daily Checklist	46
5.2.2	Function Test	47
5.2.3	Weekly Checklist	48
5.3	Oxygen Monitor Set-up	49
5.3.1	Installation	49
5.3.2	Calibration	49
5.3.3	Sensor Low Indication	51
5.3.4	Setting the High and Low O ₂ Alarms	51
6.	USER MAINTENANCE	
6.1	Service Schedule	52
6.2	Cleaning	52
6.2.1	Outside Surfaces	52
6.2.2	Bellows and Diaphragm Exhalation Valve	53
6.2.3	Spirometer Sensors	54
6.2.4	Patient Connector Block	55
6.3	Sterilisation	56
6.4	Oxygen Monitor - Cleaning and Sterilisation	57
6.5	Oxygen Sensor Replacement	57
7.	APPENDIX	
1.	Back-up Battery	58
2.	Menu System	59
3.	Ventilator Spirometry System	62

USER RESPONSIBILITY

This anaesthesia ventilator has been built to conform with the specification and operating procedures stated in this manual and/or accompanying labels and notices when checked, assembled, operated, maintained and serviced in accordance with these instructions.

To ensure the safety of this device it must be checked and serviced to at least the minimum standards laid out in this manual. A defective, or suspected defective, product must not under any circumstances be used.

The user must accept responsibility for any malfunction which results from non-compliance with the servicing requirements detailed in this manual.

Additionally, the user must accept responsibility for any malfunction which may result from misuse of any kind or non-compliance with other requirements detailed in this manual.

Worn, broken, distorted, contaminated or missing components must be replaced immediately. Should such a repair become necessary it is recommended that a request for service advice be made to Paragon Service.

This device and any of its constituent parts must be repaired only in accordance with written instructions issued by the manufacturer and must not be altered or modified in any way without the written approval of the manufacturer. The user of this equipment shall have the sole responsibility for any malfunction which results from improper use, maintenance, repair, damage or alteration by anyone other than the manufacturer.

USA and Canadian Federal Law restricts the sale and use of this device to, or on the order of, a licensed practitioner.

Statements in this manual preceded by the following words are of special significance:

WARNING *means there is a possibility of injury to the user or others.*

CAUTION *means there is a possibility of damage to the apparatus or other property.*

NOTE *indicates points of particular interest for more efficient and convenient operation.*

Always take particular notice of the warnings, cautions and notes provided throughout this manual.

1. WARNINGS AND CAUTIONS

The following WARNINGS and CAUTIONS must be read and understood before using this ventilator.

WARNINGS

General Information

1. *Personnel must make themselves familiar with the contents of this manual and the machine's function before using the ventilator.*

Before Using the Ventilator

2. *Before the ventilator is used clinically for the first time, verify that the hospital engineering department has carried out an earth continuity test.*
3. *Excessive electronic noise caused by other poorly regulated devices, such as an electrocautery unit, may adversely interfere with the proper functioning of the ventilator.*

To avoid this problem, do not connect the ventilator's power cord into the same electrical wall outlet or adaptor strip into which an electrocautery unit is connected.

4. *If used with a mains extension cord, the unit may be subject to electro-magnetic interference.*
5. *The driving gas supply must be clean and dry to prevent ventilator malfunction.*
6. *This ventilator is designed to be driven by oxygen or medical air only. It is calibrated during manufacture for use with either gas.
Before the ventilator is used clinically for the first time, the commissioning engineer must confirm that the internal Air/Oxygen switch is set correctly for the gas that is to be used.
The use of any other gas will cause inaccurate operation and may damage the ventilator, resulting in potential injury to the patient.*

7. *The driving gas is discharged through the opening in the back of the ventilator control unit.*

The discharged gas may contaminate the environment, and should therefore be extracted using a gas scavenging system.

8. *The bellows can only support approximately 1 kPa (10 cmH₂O) differential positive pressure, above which it may be dislodged from the mounting ring, resulting in dangerous malfunction of the ventilator.*

Do not connect a positive end expiratory pressure (PEEP) valve or other restrictive device to the exhaust port on the bellows base.

This would increase the pressure inside the bellows and the bellows could detach from the base, causing serious malfunction.

9. *Breathing System*

The breathing system which conveys gases from the anaesthetic machine to the patient, and disposes of expired gases, must conform to the requirements of ISO 8835-2.

Because breathing systems require frequent cleaning and disinfection they are not a permanent part of the anaesthetic ventilator and therefore cannot be directly under the control of the anaesthetic ventilator manufacturer. However, we strongly recommend that only breathing systems which have been approved and authorised by the manufacturer for use with AV-S should be employed.

Do not use conductive breathing system hoses.

When mechanical ventilation is employed the patient breathing system must be connected directly to a pressure relief valve to prevent the possibility of barotrauma.

10. *Do not connect a spirometer to the exhaust port on the bellows base. The device will not measure exhaled volumes in that position.*

WARNINGS AND CAUTIONS

11. *The operation of each alarm function should be verified daily.*

Periodically check the alarms at clinically suitable intervals. If the audible alarm or the visual indicator of any alarm function fails to activate during any alarm condition or fails to reset after the alarm has been cleared, refer the unit to an authorised service technician.

12. *Before using the ventilator check that all connections are correct, and verify that there are no leaks.*

Patient circuit disconnects are a hazard to the patient. Extreme care should be taken to prevent such occurrences.

It is recommended that Safelock fittings are used throughout the breathing circuit.

13. *Check that the cable between the control unit and remote display screen unit is connected before use. Always use a cable type recommended by the manufacturer.*

Using the Ventilator

14. *The AV-S ventilator is not intended for use in intensive care applications.*

15. *This apparatus must not be used with, or in close proximity to, flammable anaesthetic agents. There is a possible fire or explosion hazard.*

16. *Anaesthesia apparatus must be connected to an anaesthetic gas scavenging system (AGSS) to dispose of waste gas and prevent possible health hazards to operating room staff. This requirement must be observed during test procedures as well as during use with a patient. The scavenging transfer and receiver system must conform to ISO 8835-3. Any problem arising from an improperly functioning scavenging system is solely the user's responsibility. Do not use a scavenging system that restricts drive gas flow when negative pressure is exerted on it.*

17. *When the ventilator is connected to a patient, it is recommended that a qualified practitioner is in attendance at all times to react to an alarm or other indication of a problem.*

18. *In compliance with good anaesthesia practice, an alternative means of ventilation must be available whenever the ventilator is in use.*

19. *It is recommended that the patient oxygen concentration should be monitored continuously.*

20. *If the drive gas supply pressure drops below a nominal 241 kPa (35 psi), the LOW DRIVE GAS SUPPLY alarm will activate both audibly and visually. Patient minute volume may be reduced due to lowered flow rates*

21. *An audible alarm indicates an anomalous condition and should never go unheeded.*

22. *The characteristics of the breathing circuit connected between the ventilator and the patient can modify or change patient ventilation.*

To assist the maintenance of the delivered patient tidal volume, the ventilator control system software includes:

- A) a compliance compensation algorithm,*
- B) a fresh gas compensation algorithm.*

However, patient ventilation must be monitored independently from the ventilator.

It is the responsibility of the user to monitor patient ventilation.

23. *Care must be taken to ensure that the flow sensors are connected correctly to the inspiratory and expiratory ports of the absorber.*

24. *The Vent Inop (ventilator inoperative) alarm indicates that one of the following conditions has occurred:*

- a) The drive gas solenoid has failed.*
- b) The flow control valve has failed.*
- c) Internal electronic fault.*
- d) Internal electrical fault.*
- e) Software error.*

WARNINGS AND CAUTIONS

Note that if a ventilator error is detected, 'Ventilator Inoperative' will be displayed on the front control panel display.

25. *The High and Low Airway Pressure Alarms are important for patient care. It is important that the sensor is properly located in the expiratory limb of the circuit - refer to section 5.1.10.*
26. *The patient must be continuously attended and monitored when Advanced Breathing Modes are in use.*

User Maintenance

Control Unit

27. *Opening the control unit by unauthorised personnel automatically voids all warranties and specifications.*

Prevention of tampering with the control unit is exclusively the user's responsibility. If the control unit seal is broken, the manufacturer assumes no liability for any malfunction or failure of the ventilator.

28. *For continued protection against fire hazards, replace the two fuses only with the identical type and rating of fuse.
See section 4 for fuse rating.*
29. *If the internal battery is fully discharged, the ventilator will not function in the event of mains power failure. The battery must be recharged before the ventilator is used clinically, otherwise backup cannot be guaranteed.
See Appendix for battery maintenance.
See also CAUTION No. 7.*

Used or defective batteries must be disposed of according to hospital, local, state, and federal regulations.

30. *No oil, grease or other flammable lubricant or sealant must be used on any part of the ventilator in close proximity to medical gas distribution components.
There is a risk of fire or explosion.*

31. *Exterior panels must not be removed by unauthorised personnel and the apparatus must not be operated with such panels missing.
There is a possible electric shock hazard.*

Bellows Assembly

32. *The valve seat on the patient gas exhalation diaphragm valve in the base of the bellows assembly must be cleaned regularly - see section 6.2.
Failure to keep the valve seat clean could result in the diaphragm sticking, thus preventing exhalation.*

Great care must be taken not to damage the precision surface of the valve seat on the patient gas exhalation diaphragm valve in the base of the bellows assembly.

Never use any hard object or abrasive detergent to clean it; use only a soft cloth.

If the valve seat is damaged, the valve will leak and may cause serious ventilator malfunction.

WARNINGS AND CAUTIONS

CAUTIONS

1. Do not sterilise the ventilator control unit. The patient block assembly must be removed from the control unit before sterilisation (see section 6.2.4). All other internal components are not compatible with sterilisation techniques and damage may result.
2. For ventilator components which require sterilisation, peak sterilisation temperatures should not exceed 136°C (275°F) to prevent possible damage. (See section 6).
3. Those parts suitable for ethylene oxide sterilisation should, following sterilisation, be quarantined in a well ventilated area to allow dissipation of residual gas absorbed by the components. Follow the steriliser manufacturer's recommendations for any special aeration periods required.
4. The exhalation valve located in the bellows base assembly and the paediatric bellows adaptor must be cleaned and sterilised separately. See section 6.
5. Care must be taken not to let any liquid run into the control unit; serious damage may result.
6. Always check for correct fitment, and carry out a full function test before clinical use, if the bellows has been removed and refitted for any reason. See section 6.
7. Damage may occur to the battery if it is allowed to remain in a discharged state. Check the battery frequently if the ventilator is in storage (see Appendix 1).
8. Fresh gas compensation is disabled if :
 - a) The spirometry system is turned OFF through the menu system, or
 - b) The spirometry system is not functioning correctly.
9. Fresh gas mixture compensation is disabled if :
 - a) The spirometry system is turned OFF through the menu system, or
 - b) The spirometry system is not functioning correctly.
 - c) The O₂ monitor is switched OFF.
10. Circuit compliance is not activated until Fresh Gas Compensation is switched OFF.

NOTES

1. The term 'cycle' is used to designate the transition to the exhalation phase.
2. The term 'trigger' is used to indicate the transition to the inhalation phase.

WARNINGS AND CAUTIONS - Oxygen Monitor

Oxygen Monitor

WARNINGS

1. **We recommend calibration of the oxygen monitor every time the system is turned on, as a safety precaution.**
2. **Do not attempt to open the fuel cell. The sensor contains small quantities of :**
 - a) **electrolyte, classified as a harmful irritant which is potentially hazardous, and**
 - b) **lead.**

Used or defective cells must be disposed of according to hospital, local, state, and federal regulations.
3. **ALWAYS check the integrity of the sensor assembly before use.**
4. **Once exhausted, the sensor must be disposed of according to hospital, local, state and federal regulations.**
5. **The sensor measures oxygen partial pressure, and its output will rise and fall due to pressure change. An increase in pressure of 10% at the sensor inlet will produce a 10% increase in sensor output.**

CAUTIONS

1. **Only use low temperature ethylene oxide sterilisation for the oxygen sensor. The sensor is not compatible with other sterilisation techniques - damage may result. Do not sterilise any other components.**
2. **Do not autoclave or expose the sensor to high temperatures.**
3. **If the sensor shows signs of being affected by condensation, dry the sensor with soft tissue. Do not use heat to dry the sensor.**

NOTES

1. **The O2 SENSOR FAULT alarm indicates that one of the following conditions has occurred.**
 - a) **Internal electrical fault**
 - b) **Software/electronics fault**
 - c) **Oxygen sensor fault.**
2. **The concentration read-out may, in certain conditions of excess pressure, show a value above 100%. To accommodate these conditions it is possible to set the high alarm value up to 105% (see section 5).**
3. **To maintain maximum sensor life:**
 - i) **always switch off the anaesthetic machine after use, to ensure that the basal flow ceases.**
 - ii) **disconnect the breathing circuit after use.**
4. **The accuracy of flow and volume measurements may be reduced if the oxygen monitor is not in use.**
5. **Fresh gas mixture compensation is disabled if the oxygen monitor is switched OFF.**

2. PURPOSE

The AV-S Ventilator is a software controlled, multi-mode ventilator, designed for mechanical ventilation of adult and paediatric patients under general anaesthesia.

In addition, in spontaneous mode, it can be used to monitor spontaneously breathing patients

It is designed for use in closed-circuit anaesthesia and also to drive a Mapleson D circuit.

Indications for use of the device:

The AV-S Ventilator is intended to provide continuous mechanical ventilatory support during anaesthesia. The ventilator is a restricted medical device intended for use by qualified trained personnel under the direction of a physician. Specifically the ventilator is applicable for adult and paediatric patients.

The ventilator is intended for use by health care providers, i.e. Physicians, Nurses and Technicians with patients during general anaesthesia.

The AV-S ventilator is not intended for use in intensive care applications.

Oxygen Monitor

The Oxygen Monitor is intended to continuously measure and display the concentration of oxygen in breathing gas mixtures used in anaesthesia, and is intended for adult and paediatric patients.

The oxygen monitor is an integral part of the ventilator.

The oxygen monitor is intended for use by health care providers, i.e. Physicians, Nurses and Technicians for use with patients during general anaesthesia.

3. DESCRIPTION



AV-S Ventilator

3.1 General Description

The AV-S Ventilator is a pneumatically driven, software controlled, multi-mode ventilator.

The ventilator is a time-cycled, volume/pressure controlled, and pressure limited.

The ventilator has compliance compensation and a user selectable option of an inspiratory pause fixed at 25% of the inspiratory time. In addition, fresh gas compensation and user selectable gas mixture compensation is a standard feature.

Ventilation Modes

Volume Mode - continuous mandatory ventilation

Pressure Mode - pressure controlled ventilation

Spontaneous, with advanced PSV (Pressure Support Mode)

PEEP

Patient Monitoring

Airway pressure, measured from the expiratory limb of the breathing circuit.

Tidal volume and Minute Volume measurement is provided by a dual spirometry system

An integral oxygen monitor system measures oxygen concentration in the breathing circuit inspiratory limb.

The print function provides a permanent record of function activity for up to eight hours during a procedure, or can be used to record waveforms.

Screen

210 mm (8.4 inch) high definition, colour TFT screen, with single/dual waveform display. Remote mounted on an arm.

DESCRIPTION

Bellows unit

The bellows unit (1) is built into the A200SP absorber.

A paediatric bellows assembly is available as an option

Mounting options

The AV-S integral screen and control unit can be mounted securely on the anaesthetic machine shelf or side bracket.

Drive gas supply

The supply must be at 310 to 689 kPa (45 to 100 psi).

The ventilator drive gas supply can be oxygen or air.

Note that the drive gas is specified by the customer prior to delivery. Conversion from one drive gas to another must be carried out by a service engineer trained by the manufacturer.

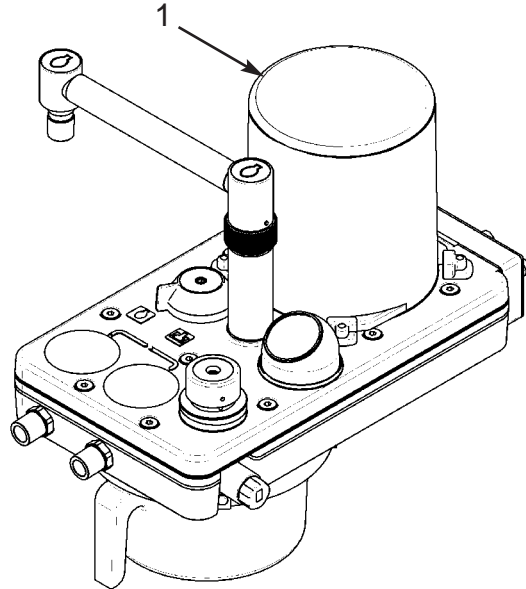

DESCRIPTION

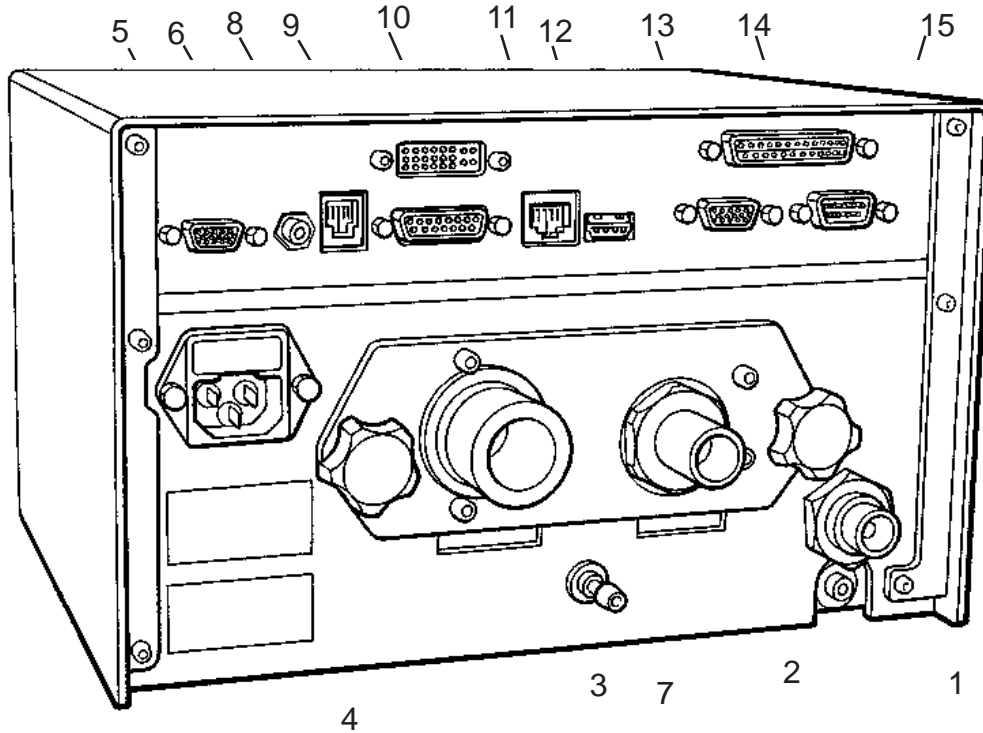

Control Unit Rear Panel

Gas Connections

1. Ventilator drive gas inlet
- connect to anaesthetic machine
auxiliary gas outlet
2. Bellows Drive Gas Output
- connect to bellows via A200SP
absorber - see section 5.1.5)
3. Outlet - Exhaust Valve

Electrical Connection

4. Electrical mains input and fuse unit

Interface and Parameter inputs

5. A200SP Absorber Bag/Vent
switch interface
Spirometer connector
6. Prima SP2 Interface connector
7. Pressure Monitor Port
8. Input socket - Oxygen monitor
sensor

Data and Printer Ports

9. Data Output
10. Output to remote display
11. Ethernet
12. USB
13. VGA
14. Printer port
15. RS232

NOTE

USB port is for access only by engineers
trained by the manufacturer.
All other data ports are read only.
For further information, please contact
Paragon.

DESCRIPTION

3.2 Ventilation Cycle

This section provides a simplified description of the ventilation cycle.

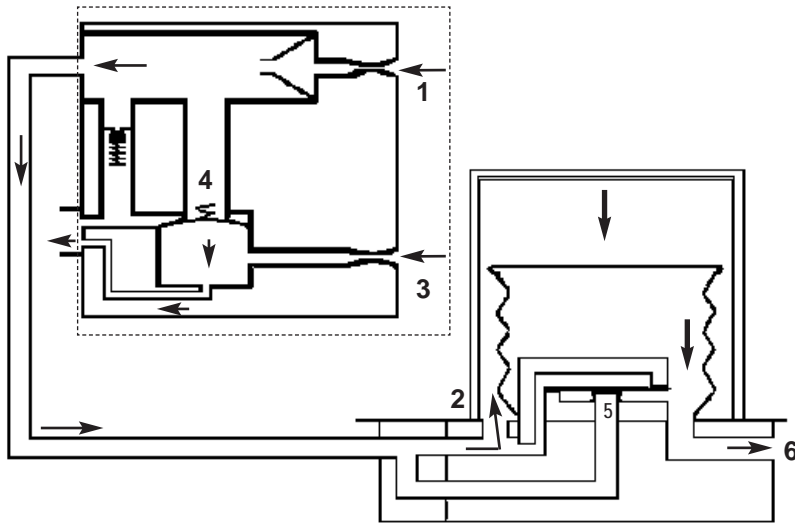

1. Inspiratory Phase

The inspiratory proportional valve (1) in the control unit opens, and bellows drive gas is delivered to the bellows housing (2). The expiratory proportional valve (3) opens and gas flows through the bleed valve. The back pressure ensures that the exhaust valve (4) is kept closed. Drive gas pressure builds up above the bellows, which starts to move down. The diaphragm (5) in the bellows assembly base is held closed, and patient gas is forced out of the bellows base (6) into the breathing system.

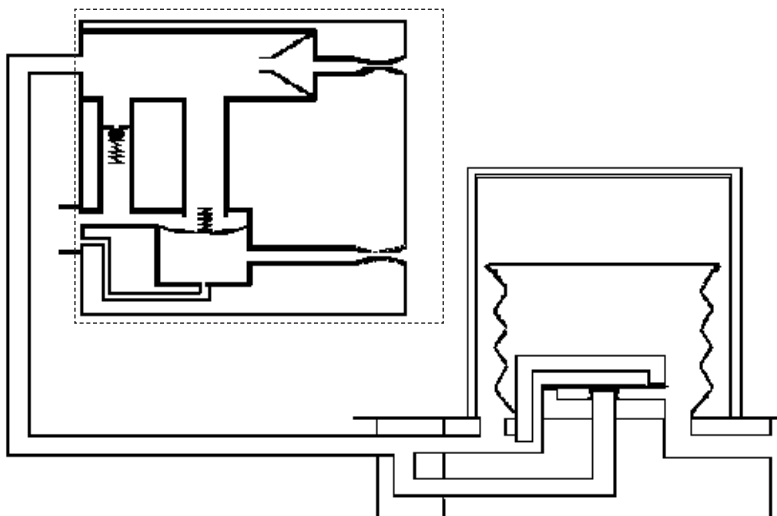

2. Beginning of Expiratory Phase

The Inspiratory (1) and Expiratory (3) proportional valves close and the exhaust valve (4) opens. Patient gas returns to the bellows. As the bellows rises, redundant drive gas is pushed out through the exhaust valve.

DESCRIPTION

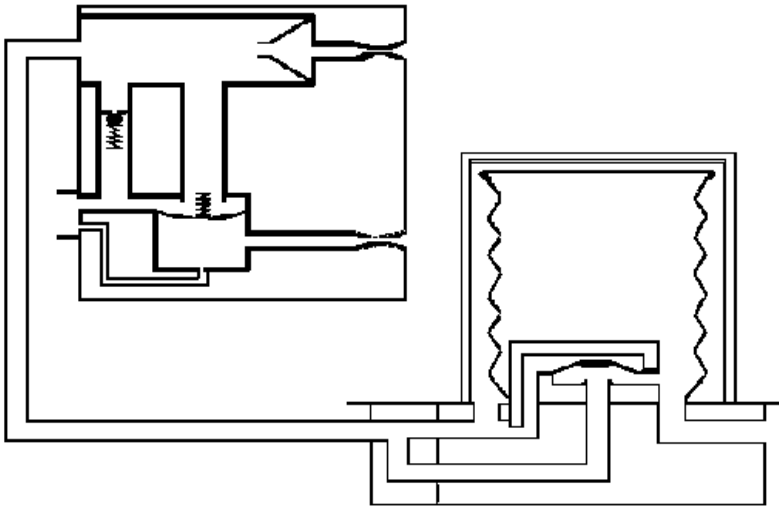

3. End of Expiratory Phase

With the bellows at the top of its housing fresh gas continues to flow. To prevent a high pressure build up the exhalation diaphragm (5) lifts and allows gas to exit through the exhaust valve (4).

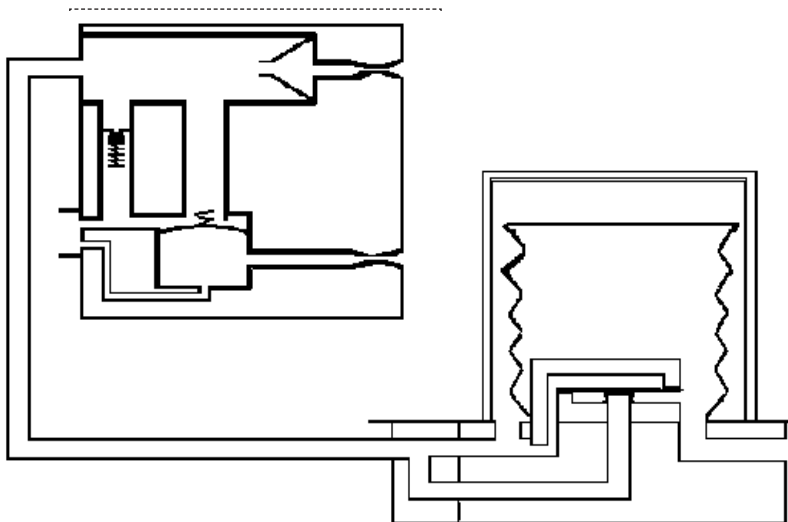

4. PEEP Positive End Expiratory Pressure (user selectable)

During PEEP the Exhalation Proportional valve (3) applies PEEP pressure plus 20 cmH₂O to the exhaust valve, which remains closed at this stage.

As fresh gas flows in the patient circuit, any pressure increase above PEEP pressure in the bellows will cause gas to bleed past the exhaust valve (4).

A continuous flow from the Inspiratory proportional valve (1) ensures that any fall in pressure is compensated by driving the bellows as required.

DESCRIPTION

Pneumatic Flow Diagram

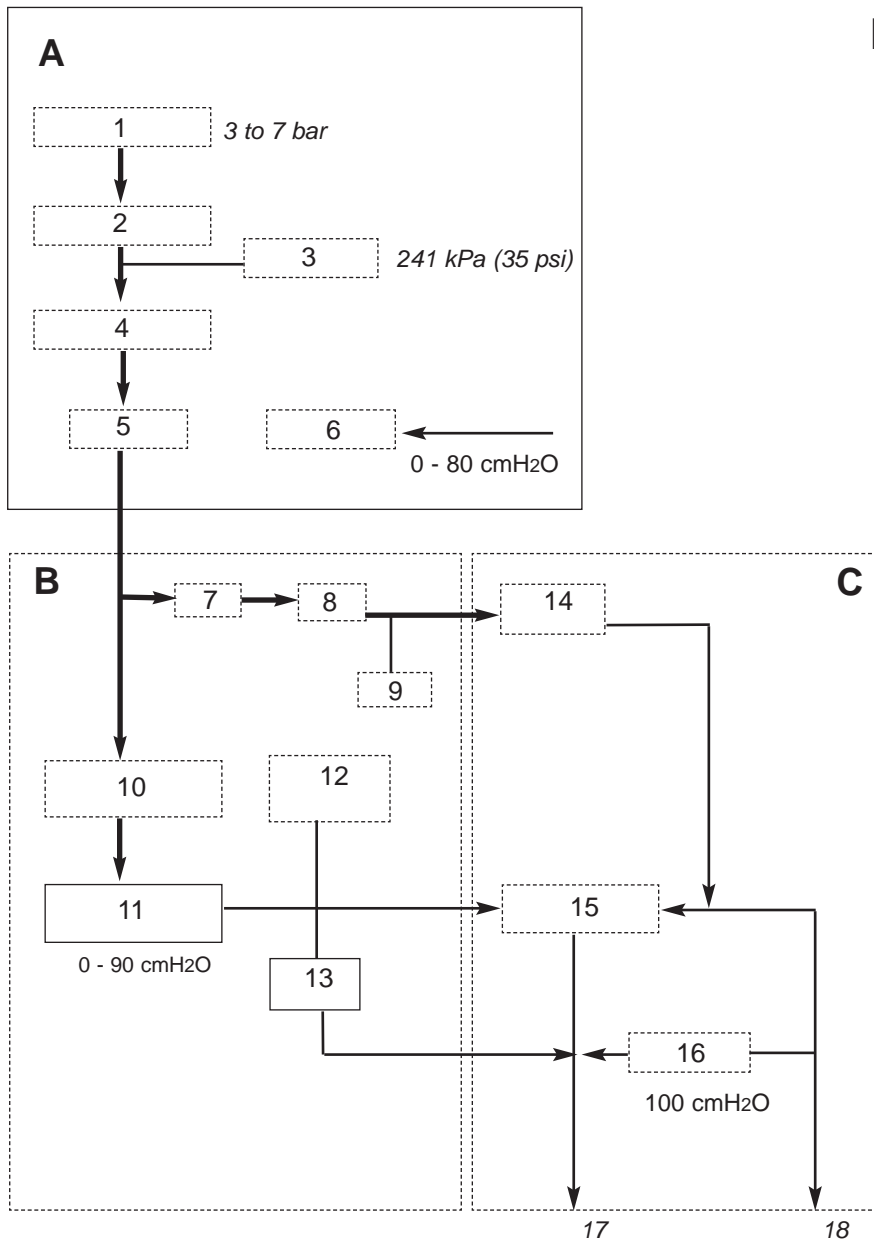

DESCRIPTION

3.3 Pneumatic System

3.3.1 System Operation

Refer to the pneumatic system diagram on the previous page.

A) Gas inlet manifold block

The AV-S Ventilator is designed to operate on a 310 - 689 kPa (45 -100 psi) drive gas supply (oxygen or air - to customer's requirement).

1. DISS Connector
The gas source is connected to the DRIVE GAS SUPPLY fitting on the rear of the ventilator control unit.
The gas supply should be capable of a flow rate of 80 L/min while maintaining a minimum pressure in excess of 310 kPa (45 psi).
2. Filter
The drive gas is filtered with a 40-micron Input Gas Filter which protects the pneumatic components from incoming particulate matter.
3. The Low Supply Pressure Detector
The pressure switch is set at a predetermined level to detect a loss or reduction of the input gas source pressure.
When the pressure falls below 235 kPa (35 psi \pm 1 psi), the LOW SUPPLY PRESSURE indicator will be displayed and the high priority audible alarm will activate.
4. Input Pressure Regulator
Regulates the input drive gas to 260 kPa \pm 21 kPa (38 psi \pm 3 psi).
5. Cut-off Valve
The valve isolates the the gas supply :
a) when the ventilator is switched off
b) when a fault condition occurs.
6. Airway Pressure Sensor
Connected to expiratory limb of breathing circuit.

B) Pneumatic Control Manifold Block

7. Inspiratory Proportional Valve
8. Flow Sensor
9. Drive Gas pressure Sensor
10. Low Pressure Regulator
11. Expiratory Proportional Valve
12. PEEP pressure sensor
13. Restrictor
The restrictor allows a flow of up to 2 L/min (<2 L/min bleeding)

C) Exhaust Manifold Block

14. Check Valve
15. Diaphragm Valve
16. Pressure Relief valve
Set to 100 cmH₂O
17. Exhaust Port (to AGSS)
18. Bellows drive gas outlet (to bellows assembly)

DESCRIPTION

3.4 Electrical System

Mains Supply

The mains supply inlet is designed for connection to any mains voltage from 100 to 240 VAC and a frequency of 50 to 60 Hz, without any adjustment.

The connector is a standard IEC type.

Back-up Battery

In the event of mains electrical failure, the back-up battery cuts in automatically.

A fully charged battery will power the ventilator for approximately 30 minutes.

See Appendix for battery care procedures.

DESCRIPTION

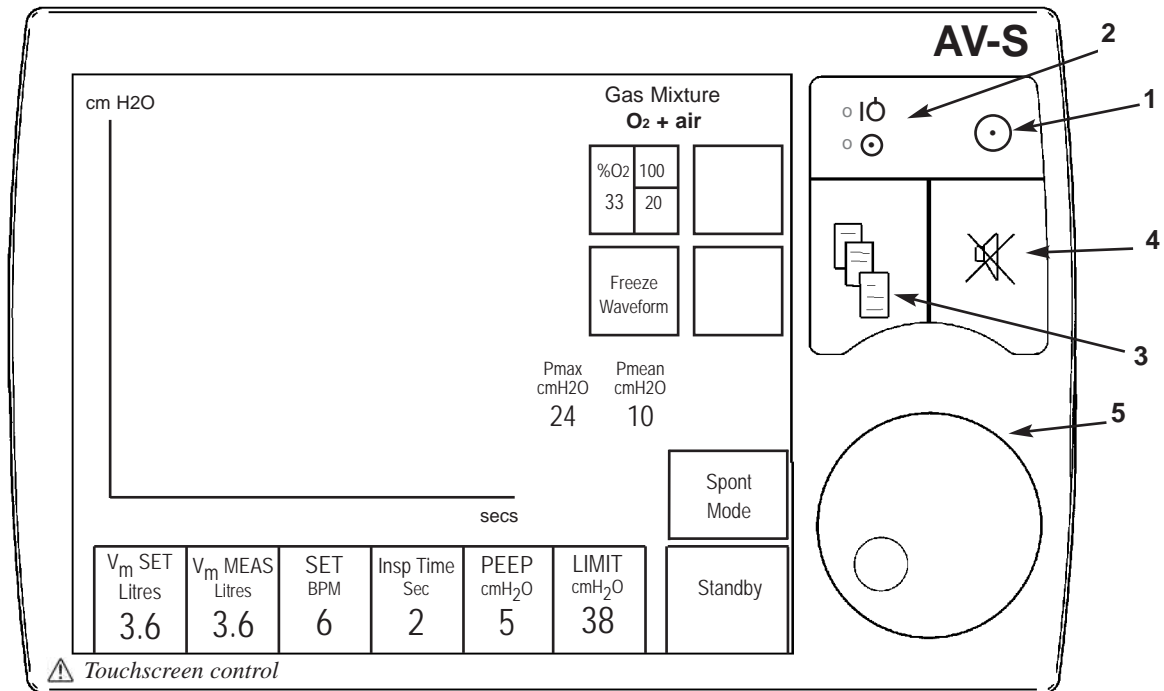

3.5 Control Panel

3.5.1 Touchscreen and Navigator Wheel / Push Button

3.5.1.1 Control Panel

- 1. On/Off control**
Switch On:
Short internal test sequence
Switch Off:
5 second power down sequence with audible tones
- 2. Status indicators for electrical power (mains/battery supply)**
Yellow indicator
- illuminated whenever power is applied to the unit and internal battery is being charged
Green indicator
- illuminates when the unit is switched on, .
- 3. Menu switch**
The menu function provides access to user and service pages
- 4. Alarm mute switch**
30 or 120 second Alarm silence, depending on alarm status.
Note also that some alarms are not mutable - see section 3.11.

5. Navigator Wheel and Press Button

Turn the wheel to select a function or parameter, or to alter the value of an active parameter.

Press to confirm the setting.

3.5.1.2 Selecting Functions and Parameters

The functions/parameters shown on the screen can be activated as follows:

a) touch the screen at the appropriate tab area.

b) rotate the navigator wheel and press it when the indicator arrow is on the required parameter tab

Note that parameters default to factory-set values when the ventilator is switched on and no further user selection is made.

3.5.1.3 User Adjustable Parameters

Variable parameters can be altered by rotating the navigator wheel.

When the required value is displayed, press the active tab or the wheel to confirm the setting.

DESCRIPTION

3.5.2 User Adjustable Parameters

Tidal Volume Range	20-1600 ml
Rate	4-100 bpm
I:E Ratio	1:0.3 to 1:8
PEEP	4-30 cmH ₂ O Can be set to OFF
Pressure Limit	
Volume mode:	10-80 cmH ₂ O
Pressure mode:	10-70 cmH ₂ O

3.5.3 Operational Capability

Tidal Volume, Rate, and I:E ratio settings are all limited by a maximum inspiratory flow of 75 L/min.

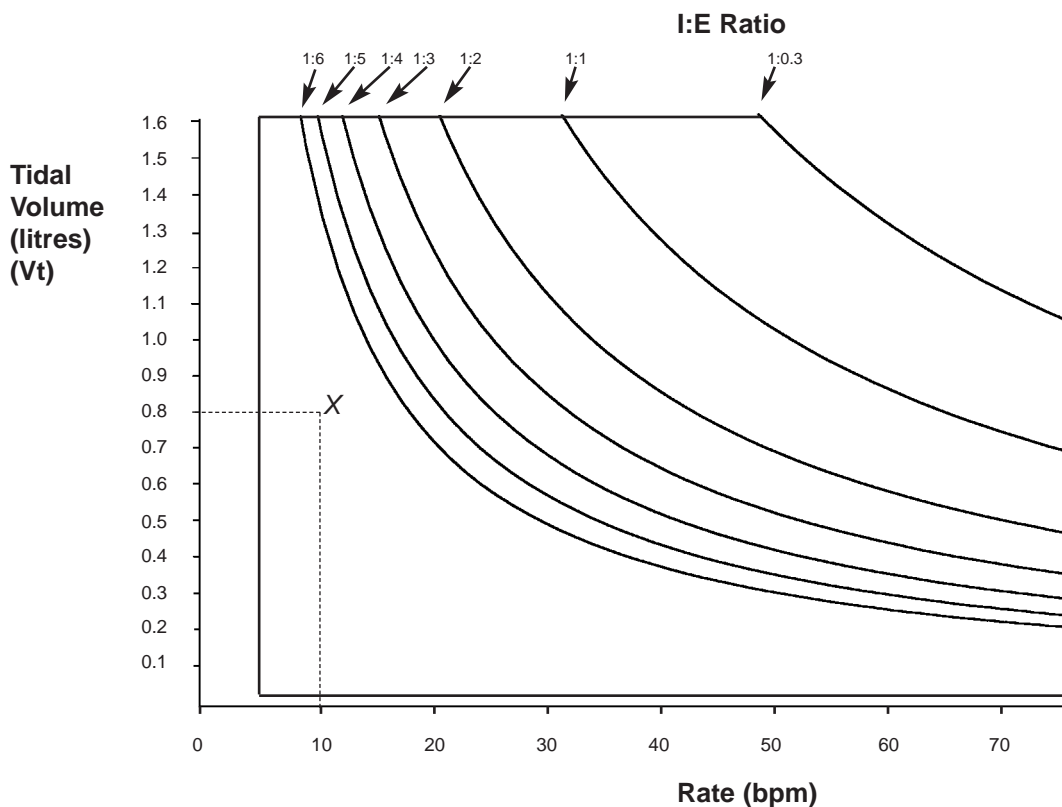

The ventilator is capable of operating at the volumes and rates below each I:E ratio curve.

Example

1. Select required volume (V_t) (e.g. 0.8 L)
2. Select rate (e.g. 10 bpm).
3. Select I:E ratio of 1:2.

The point X on the graph lies beneath the 1:2 ratio curve, and is therefore within the ventilator's capability.

DESCRIPTION

3.5.4 Output Compensation Functions

WARNING

The AV-S automatically compensates for fresh gas (spirometry On), fresh gas mixture (spirometry and oxygen monitor On), and altitude.

However, the actual tidal volume delivered to the patient may be different to the ventilation parameters set by the user, due to:

- A) an extreme compliance condition,*
- B) a substantial system leak,*
- C) patient circuit pressure effects, or*
- D) extreme fresh gas flows*

In addition, high fresh gas flows will lead to an increased Vt being delivered to the patient.

The patient must be monitored independently from the ventilator.

It is the responsibility of the user to monitor the patient for adequate ventilation.

Fresh Gas Compensation

Adjusts delivered volume up to 60%

Alarms if measured volume is 50% different than set volume

User adjustable

NOTE

Fresh gas compensation is disabled if :

- a) The spirometry system is turned OFF through the menu system, or*
- b) The spirometry system is not functioning correctly.*

Fresh Gas Mixture Compensation

- models with Spirometry

The spirometry system compensates for fresh gas mixture - the user must access the menu system and select the gas mixture that will be used for each clinical procedure.

NOTE

Fresh gas mixture compensation is disabled if :

- a) The spirometry system is turned OFF through the menu system, or*
- b) The spirometry system is not functioning correctly.*

If the O2 monitor is switched OFF, a 40%/60% mixture of O2/N2O is assumed.

Altitude Compensation

Monitors ambient pressure

Adjusts delivered volume accordingly

DESCRIPTION

3.6 Interface to Prima SP2 and A200SP

The AV-S is designed to interface with the Prima SP2 Anaesthetic Machine and the A200SP Absorber.

3.6.1 Prima SP2 Interface

The interface cable links the socket (A) on the control panel to a socket on the rear panel of the anaesthetic machine.

- a) Turn the anaesthetic machine Gas Delivery Switch to ON.
The ventilator will power-up.
- b) While the anaesthetic machine power is ON, the Ventilator can be turned OFF and ON, using the ventilator On/Off switch, as described in section 3.5.1.
- c) Turn the anaesthetic machine Gas Delivery Switch to OFF. The ventilator will power-down.

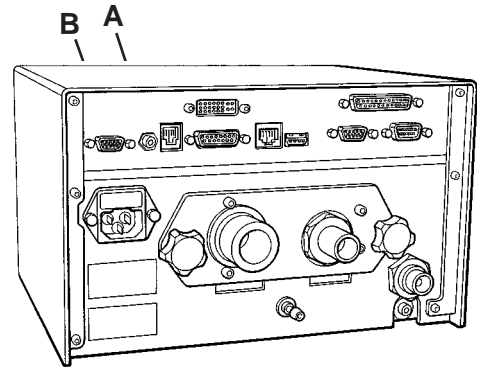

3.6.2 A200SP Absorber Interface

The interface cable links the socket (B) on the control panel to a socket (C) at the rear of the absorber.

- a) The A200SP is fitted with a sensor that detects the position of the absorber bag/vent control (D).
The sensor signal cabling is routed internally to connector (C) and a second cable runs to the rear of the AV-S control unit.
- b) Operation of the Bag/Vent control will trigger automatic Mode switching on the AV-S ventilator, as follows:
 - i) If the Absorber Bag/Vent control is moved from Vent to Bag, the ventilator will change from Volume Mode, or Pressure Mode, into Spontaneous Mode.
 - ii) Switching the absorber Bag/Vent control from Bag to Vent:
The ventilator will reset from Spontaneous Mode to the previously set active mode.
 - iii) If the ventilator is in any mode other than those detailed above, operation of the absorber Bag/Vent control will not affect the ventilator.

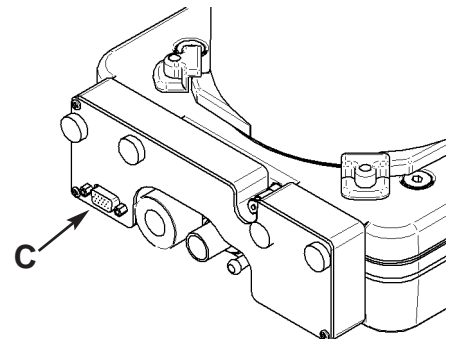
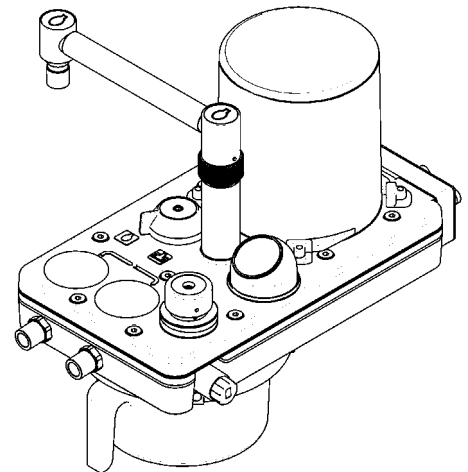

NOTE This function can be enabled/disabled through the AV-S on-screen menus (Service Sub-menu, see appendix).

DESCRIPTION

3.7 Ventilation Modes

3.7.1 Standby Mode

Allows parameters to be set.

Some patient alarms are active:

High airway pressure (at 80 cmH₂O)

High/Low O₂

Negative pressure

Incorrect Rate/Ratio

DESCRIPTION

3.7.2 Volume Mode

The ventilator delivers a mandatory set volume of gas at preset, fixed breath intervals.
The Patient is making no respiratory effort.

3.7.2.1 Fresh Gas Compensation

Adjusts delivered volume up to 60%
This delivered volume will consist of the volume delivered from the ventilator bellows plus the fresh gas flow from the anaesthetic machine fresh gas supply, minus any compliance loss and minus any leak. This gives a total actual inspired tidal volume.

An alarm is triggered if measured volume is 50% different than set volume
User adjustable

Altitude Compensation

Monitors ambient pressure
Adjusts delivered volume accordingly

3.7.2.2 Operating Functions

Inspiratory. Pause function: Creates 25% plateau

Sigh function:

When the ventilator is in Volume Cycle mode the "sigh" option is available. When selected, this option provides extra volume for 1 to 4 breaths in 50 (frequency is user selectable).

The extra volume will be 50% above the tidal volume set by the user.

Volumes measured if Spirometry function selected

Auto High and Low volume alarms if measured volume different by 50% of set volume
User adjustable option

If max pressure limit achieved, ventilator cycles to expiratory phase

3.7.2.3 Volume Type Selection

Use the menu to switch between Tidal Volume and Minute Volume.

NOTE Minute Volume is derived from a rolling average during a 30 second period.

Volume Mode Parameters

Tidal volume	20-1600 mL
Rate	4-100 bpm
I:E ratio	1:0.3 - 1:8
PEEP 'Off' or adjustable	4 - 30 cmH2O
Inspiratory pressure limit	10 - 80 cmH2O
Inspiratory pause (does not affect I:E ratio)	25%
Sigh	1.5 x Set Vt is delivered once, twice, three times or four times every 50 breaths (user selects frequency)

DESCRIPTION

3.7.3 Pressure Mode

3.7.3.1 Parameters

The ventilator delivers a volume of gas to achieve a set pressure at fixed breath intervals.

The Patient is making no respiratory effort. This is a common mode for the ventilation of small paediatric patients.

Inspiratory pressure	10 - 70 cmH ₂ O
Rate	4 - 100 bpm
I:E ratio	1:0.3 — 1:8
PEEP 'Off' or adjustable:	4 - 30 cmH ₂ O

Inspiratory decelerating flow controlled by the ventilator according to pressure setting
No Inspiratory pause function

3.7.3.2 Pressure Mode Operating Functions

Defaults to 10 cmH₂O

Maximum Inspiratory Flow to achieve target pressure

Sustaining flow maintains circuit pressure

Control achieved using exhaust valve

DESCRIPTION

3.7.4 Spontaneous Mode

3.7.4.1 Parameters

The ventilator monitors the following patient parameters:

Rate
I:E ratio
Pressure
Tidal volume

Provides waveform displays

Inspiratory oxygen is measured

3.7.4.2 Spontaneous mode operating functions

No mechanical ventilation
No Inspiratory Pause function

Patient Monitoring (Bag mode and Ventilator mode):

Airway pressures
FiO₂,
V_t,
Rate
I:E ratio,
Supply pressures
Ventilation conditions

Advanced Spontaneous Breathing mode is selectable from this mode - see below, and section 3.7.5.

3.7.4.3 Advanced Spontaneous Breathing Mode

Support mode available from 'Special Mode' (select from main menu):

PSV (Pressure Support Ventilation) - see section 3.7.5.

The A200SP Absorber Bag/Vent control must be in 'Vent' position for this mode to be selected.

Note that if the system fails to detect an absorber bag/vent switch, a confirm message will be displayed.

DESCRIPTION

3.7.5 PSV Pressure Supported Ventilation

PSV assists each spontaneous breath to achieve a preset pressure, thus reducing the effort required to breathe. Inspiratory flow (generated by the patient's spontaneous breath) results in synchronised pressure support.

PSV is used to support spontaneously breathing patients ONLY

If the patient makes no attempt to breathe, the ventilator will not provide support and the apnoea alarm will be activated.

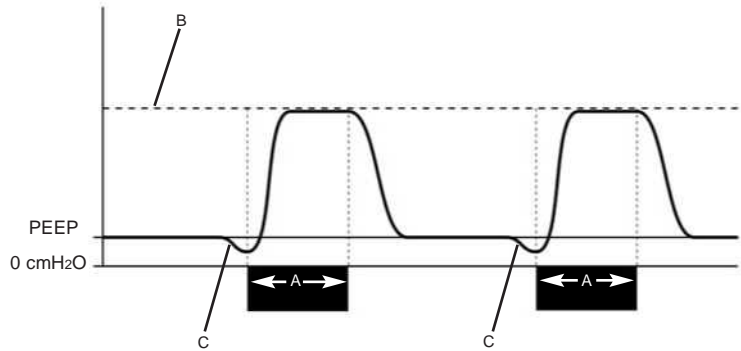

PSV Pressure Supported Ventilation

A = Set Inspiratory Time

B = Pressure Support Level

C = Spontaneous Breath results in a synchronised pressure supported breath

PSV - Selection

- Select Standby Mode
- Select Menu
- Select Special Modes
- Select PSV

PSV is now indicated on the main screen in Spontaneous mode.

NOTE

1. The trigger window is pre-set to 60% of the BPM cycle time.
2. The trigger pressure is PEEP referenced.
3. If the Spirometry is disabled then PSV is not available.
4. If the pressure limit and alarm are activated the inspiratory phase is terminated.

PSV Default Settings

The ventilator will default to the settings shown in the table, after selecting 'PSV' from Spontaneous Mode.

Note that Support Pressure can be adjusted before PSV is confirmed.

Trigger setting defaults to 0.4 litres/min, and is adjustable between 0.2 and 1.0 litres/min.

Default Settings - PSV

	Adult	Paediatric	Overall range
P. Supp	10 cmH ₂ O	10 cmH ₂ O	3-20 cmH ₂ O
Insp. (Ti)	2 sec	1 sec	I:E display box
Trigger level	0.4 L/min	0.4 L/min	0.2 to 1.0 L/min

DESCRIPTION

3.7.6 PEEP (Positive End Expiratory Pressure)

The AV-S ventilator includes a microprocessor-controlled, electronically integrated PEEP system, regulated using secondary pressure on the exhaust diaphragm.

The ventilator controls PEEP by allowing flow from, or delivering flow into the bellows drive circuit, maintaining pressure

PEEP is electronically controlled

Variable from 4-30 cmH₂O in increments of 1 cmH₂O

Clear "OFF" indication when not in use

Switch off the ventilator - PEEP is switched off.

PEEP is switched off during 'Spont' mode to minimise patient's breathing effort.

Selecting PEEP

Select by touching the screen tab PEEP, or using the navigator wheel

The setting will flash.

Rotate the navigator wheel to set the required PEEP pressure.

A confirm message will be displayed.

Press the Screen Tab, or Wheel to confirm.

Note that Electronic PEEP does not function in Spontaneous Mode.

PEEP on/off sequence

Using the A200SP Absorber Interface - Ventilator Mode Selection

1. Ventilator is in Volume Ventilation Mode
2. PEEP selected, pressure set to required level.
PEEP display indicates pressure
3. A200SP Absorber Bag/Vent control (A) is moved to 'Bag' position.
Ventilator automatically switches to Spontaneous Mode.
PEEP is automatically switched off (*does not function in Spontaneous Mode*)
PEEP display is blank.
4. Bag/Vent control reset to 'Vent' position.
Ventilator automatically switches to the mode previously set by the user.
PEEP is Off.
PEEP display indicates Off.
5. Set ventilator to Volume Ventilation Mode.
PEEP remains Off.
Select PEEP if required.

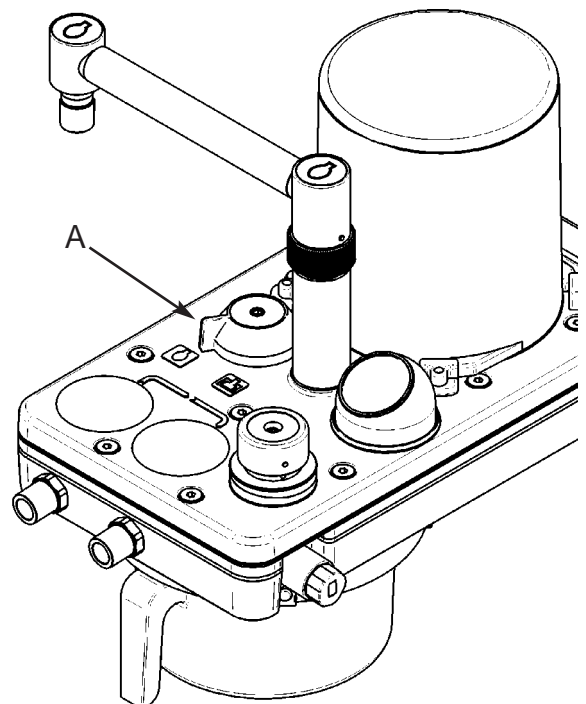

DESCRIPTION

3.8 On-Screen Menus

To Access:

Press the menu switch on the front panel to access the following functions and parameters via drop-down menus:

EXIT MENU
O2 MONITOR & SPIROMETRY
FRESH GAS COMPENSATION: ON
SPECIAL MODES
WAVEFORM
ALARM SETTINGS
GAS MIXTURE: O2+AIR
USER SETTINGS
SERVICE MENU

To Exit:

Press the menu switch on the front panel, or, select EXIT MENU and press the wheel.

NOTE

The menu window will **not** be displayed if:

- A) Control parameters (VT MEAS, BPM, I:E, PEEP, or LIMIT) are enabled but not confirmed.
- B) A display window is active

To Operate:

1. Rotate the navigator wheel clockwise to scroll through the menu options - the cursor (>) aligns with each parameter in turn.
2. Press the wheel to enter the required sub-menu.
3. Rotate the navigator wheel to change any displayed values, and press to confirm.
4. To exit the menu display:
 - A) Press the menu switch on the front panel .
 - B) Scroll to EXIT MENU and press the navigator wheel.

NOTE

- A) If confirmation does not take place within 8 seconds, the parameter reverts to its previous value.
- B) If another parameter is selected using the touchscreen, the menu is de-selected.
- C) While any menu is selected:
 - the alarms are active,
 - the ventilator can be switched off.

See Appendix 2 for a full description of the Menu system.

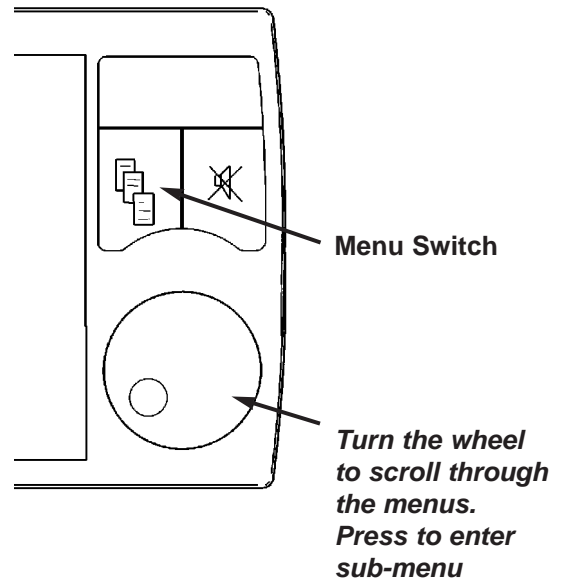

DESCRIPTION

3.9 Spirometry

Spirometry can be enabled, or disabled via the on-screen menu system.

NOTE

If the spirometry system is turned OFF:

- a) *Fresh gas / fresh gas mixture compensation is disabled.*
- b) *Special Mode is disabled.*

See Appendix 3, for a detailed description of the spirometry system.

3.10 Display Waveforms

Default waveform is always Pressure v Time (cmH₂O v seconds)

Wave Freeze is available when ventilation is in progress.

Second waveform

A second waveform can be displayed by using menu control or touch waveform on screen.

The second waveform is selectable:

Volume v Time (litres v seconds)

Volume v Pressure (litres v cmH₂O)

Compliance loop waveform

- First loop can be frozen
- Subsequent loops overlaid

Display Functions

Automatic Scale adjustment

Y axis

- a) Scale adjusts as P_{limit} is changed (-20 to 40, 60, 80 cmH₂O)
- b) In *Vol. v Time* mode as V_t is changed (0 to 0.5 L, 1.0 L, 2.0 L)

X axis

- a) Scale adjusts as Rate is changed (0 to 15 sec, 5 sec, 3 sec)
- b) In *Vol. v Pres.* mode as P_{limit} is changed (-20 to 40, 60, 80 cmH₂O)

DESCRIPTION

3.11 Alarms

Alarm	Priority	Trigger	Mute time	Set by:
Ventilator Inoperative	High	Internal failure or Battery failure	zero	Automatic
Power About to Fail	High	Ventilator is on battery, and the battery voltage is less than 10.2 v	zero	Automatic
Low Drive Gas Supply Pressure	High	Less than 235 kPa (35 psi +/-1 psi)	zero	Automatic
Low Bellows Drive Gas Pressure	High	Fails to reach target level	30 s	Automatic
High Bellows Drive Gas Pressure	High	Exceeds calculated target level	30 s	Automatic
High Continuous Airway Pressure	High	Breathing system pressure fails to return to below 30 cmH ₂ O by the start of the next inspiratory phase	120 s	Auto
High Airway Pressure	High	Pressure reaches set limit (10 to 80 cmH ₂ O adjustable)	30 s	User / Default
Low Airway Pressure	High	Breathing system pressure fails to reach minimum level	120 s	Default
Negative Airway Pressure	High	Breathing system pressure exceeds 10 cmH ₂ O	120 s	Automatic
Low Tidal Volume	High	a) Measured V _t less than 50% of volume set b) Spirometer disconnected	120 s	User / Default
Low Minute Volume	High	Calculated volume lower than 50% of volume set	120 s	User / Default
Apnoea	High	In Spontaneous mode, no breath detected within 15 seconds	120 s	Auto
High Tidal Volume	High	Measured value exceeds 150% of set value	120 s	User / Default
High Minute Volume	High	Calculated value exceeds 150% of set value	120 s	User / Default
High O ₂ Concentration	High	Measured O ₂ % exceeds set value	120 s	User / Default
Low O ₂ Concentration	High	Measured O ₂ % lower than set value	120 s	User / Default
O ₂ Sensor low output	Low	Sensor life exhausted	zero	Auto
O ₂ sensor fault	High	Sensor disconnected	120 s	Auto
Incorrect Rate or Ratio	Medium	Settings outside 75 L/min	120 s	Auto
Mains Failure	Low	Mains power fails 30 minutes use available (if battery is fully charged)	zero	Auto
Battery Power Fail	Medium	Battery disconnected, or missing, or totally discharged	120 s	
Low Battery	Low	Battery voltage has dropped below 11.2 v	zero	
Absorber cable fault (A100SP)	Medium	Disconnection or short circuit	120 s	Auto
Printer not available	Low	Printer disconnected, or has no power, or has no paper	zero	

Priority identification:
 High Priority: 5 ascending tones - repeated Medium Priority: 3 ascending tones - repeated Low Priority: Single Tone - repeated

DESCRIPTION - O₂ Monitor

3.12 Oxygen Monitor

The oxygen monitor continuously measures and indicates the concentration of oxygen in the breathing system, and triggers an alarm when the concentration varies from the set levels.

3.12.1 System Description

The Oxygen Monitor uses a fast-responding, oxygen-specific, self powered sensor that achieves 90% of final value in less than 10 seconds.

An external probe (1) is supplied with a 2 m (6 ft) extendable cable.

The system has user-adjustable high-level and low-level alarms with visual and audible indication of alarm conditions.

Bacterial Filter

Use a breathing system bacterial filter in the expiratory limb of the breathing circuit to protect the oxygen sensor (see section 5).

CAUTION

Replacement/Disposal - always follow the instructions supplied with the filter, and always replace at the recommended interval.

3.12.2 The MOX-3 Oxygen Sensor

The MOX-3 oxygen sensor offers quick response, linear output over the entire 0-100% oxygen range, and long service life.

The MOX-3 is a self-powered galvanic cell that generates a current proportional to oxygen concentration.

The cell has a highly stable output over its operating life. Significant output loss is only shown at the very end of its life.

Typical sensor drift rates are less than 1% per month when the sensor is exposed to gas in typical applications.

Sensor life:

approximately 1500000 O₂ percent hours at 20°C
(minimum one year in most normal applications).

Sensor lifetime is governed by the mass of lead available to react with the oxygen and its rate of consumption. High oxygen partial pressure and high temperature will increase the sensor output current, thus shortening the operation life.

At the point where all lead has been consumed, the output will fall very quickly to zero over a period of two to three weeks.

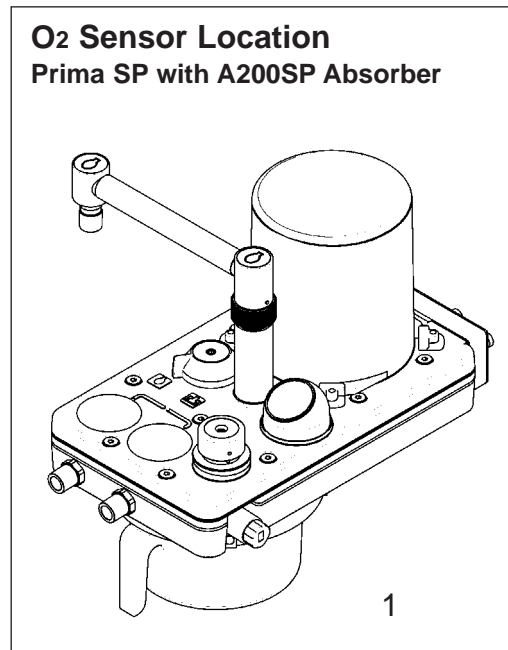

DESCRIPTION

3.12.3 O₂ Monitor sub-menu

ON/OFF

Turn the navigator wheel to switch between ON and OFF.

Press to confirm.

Scroll to EXIT MENUS and press the wheel to exit.

NOTE

The oxygen monitor automatically switches ON and defaults to the previous values for high and low alarm settings when the ventilator is switched on.

Fresh gas mixture compensation is disabled if the O₂ monitor is switched OFF.

CALIBRATION

Press the navigator wheel to initiate the calibration procedure (see section 5.3.2 for full procedure).

To exit the menu, scroll to EXIT MENUS and press the wheel.

HIGH ALARM SET

LOW ALARM SET

Scroll to the required parameter and press the navigator wheel to activate.

Rotate the navigator wheel again to change the displayed value.

(see section 5.3.4 for full procedure).

High Alarm range: 19% to 105%

Low Alarm range 18% to 99%

The displayed figure will flash on and off.

Press to confirm.

Scroll to EXIT MENUS and press the wheel to exit.

O₂ Monitor sub-menu

O₂ Monitor & Spiro

ESCAPE FROM MENU
> O₂ MONITOR: on
CALIBRATION: 100%
HIGH ALARM SET: 105
LOW ALARM SET: 18
SPIROMETER: on
SPIRO CALIBRATION: 0 L/min

O₂ Monitor sub-menu - calibration

O₂ Monitor & Spiro

ESCAPE FROM MENU
O₂ MONITOR: on
> CALIBRATION: 100%
HIGH ALARM SET: 105
LOW ALARM SET: 18
SPIROMETER: on
SPIRO CALIBRATION: 0 L/min

O₂ Monitor sub-menu - alarms

O₂ Monitor & Spiro

ESCAPE FROM MENU
O₂ MONITOR: on
CALIBRATION: 100%
> HIGH ALARM SET: 105
LOW ALARM SET: 18
SPIROMETER: on
SPIRO CALIBRATION: 0 L/min

DESCRIPTION - O₂ Monitor

3.12.4 Display

High-set, low-set, and oxygen concentration percentage readings are displayed on screen. Touch the tab to activate O₂ menu

Oxygen Concentration

The display provides a direct readout of measured oxygen concentrations in the range 0-100%.

Low Alarm Set - limited within 18-99%

The oxygen percentage, set by the user, at which the low alarm will be activated. To set the low oxygen alarm, see section 5.3.4.

High Alarm Set - limited within 19-105%

The oxygen percentage, set by the user, which the high alarm will be activated. Note that in certain conditions of excess pressure, the readout may show a value above 100%.

To set the high alarm, see section 5.3.4.

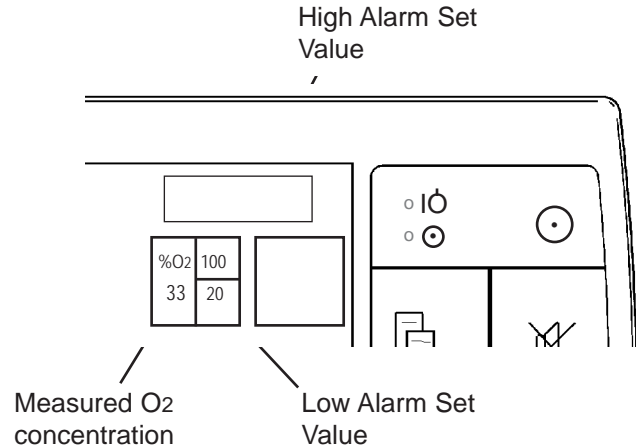

3.12.5 Display

HIGH O₂ ALARM

The high O₂ alarm is triggered when the oxygen concentration is 1% above the set value.

- The **High O₂ Alarm** visual indicator will illuminate.
- A high priority audible alarm will sound.

To cancel this alarm, the high alarm setting must be equal to, or above the oxygen concentration. The alarm can be muted for 120 seconds.

LOW O₂ ALARM

The low alarm is triggered when the oxygen concentration is 1% below the set value.

- The **Low O₂ Alarm** visual indicator will illuminate.
- A high priority audible alarm will sound.

To cancel this alarm, the low alarm setting must be equal to, or below the oxygen concentration. The alarm can be muted for 120 seconds.

O₂ SENSOR FAULT

The alarm is triggered:

- when either the oxygen sensor is disconnected or approaching the end of its life.
 - if the O₂ concentration exceeds 110%.
- The message **O₂ SENSOR FAULT** will be displayed.

- A high priority audible alarm will sound.

To cancel this alarm, check the sensor connection or replace the sensor. The alarm can be muted for 120 seconds.

O₂ SENSOR LOW

This alarm indicates the sensor has approached the end of its life.

The legend O₂ SENSOR LOW will be displayed, and a low priority alarm (single note) will sound.

The sensor must be replaced as the output will fall very quickly to zero within two to three weeks of normal usage.

See section 6.5 for sensor replacement.

3.12.6 Oxygen Monitor Alarm Mute

In an alarm condition, pressing the ALARM MUTE button will deactivate the audible alarm, but the alarm message display will remain on screen.

The switch will illuminate, and a single note will sound.

The alarm mute can not be operated:

- Until the mute time is over, or the alarm condition has been rectified.
- When O₂ concentration drops below 18%.

4. SPECIFICATION

4.1 Application	Ventilation for use in anaesthesia.
4.2 Internal Compliance	
Adult bellows	3 ml/cmH ₂ O (nominal)
Paediatric bellows	2 ml/cmH ₂ O (nominal)
4.3 Physical	
Size (mm)	
- control unit only	290 wide x 300 deep x 185 high
- with adult bellows	290 wide x 300 deep x 385 high
Screen Size	210 mm (8.4") TFT
Weight	
- control unit only	7.6 kg
- with adult bellows	9 kg
Bellows	
Adult (Latex free):	20 ml - 1600 ml
Paediatric :	20 - 350 ml
<i>(Note - latex free paediatric available as option)</i>	
Power	90 - 264 VAC, 47 - 63 Hz
Battery Back-up:	30 minutes (assumes fully charged battery)
Drive Gas	Oxygen or Air (dry, and oil free) at 45 to 100 psi (310 to 689 kPa).
4.4 Alarms	
Alarm Mute	30 or 120 seconds (see 3.11)
Low Drive Gas Pressure	Less than 235 kPa (35 psi)
High Continuous Airway Pressure	Above 30 cmH ₂ O at start of cycle
Low Pressure	4 - 14 cmH ₂ O PEEP referenced
Low Tidal Volume	50% of Volume set (Spirometry)
Incorrect Rate or Ratio	
Mains Failure	30 minutes (nominal) Battery Backup
Low Battery	5 minutes Use
Ventilator Inoperative	Internal or Battery Failure
Alarms - User Set	
Vt (Tidal)	
Min	0 - 1600 ml
Max	20 - 1600 ml
Vm (Minute)	
Min	0 - 10 L
Max	0 - 30 L
Apnoea	Adjustable Re-set Pressure (PEEP referenced)
Low and High O ₂ Concentration	18% - 105%
High Airway Pressure	10 - 80 cmH ₂ O adjustable

SPECIFICATION

4.5 Functional

Tidal Volume

Adult bellows 20 to 1600 ml ($\pm 10\%$)

Paediatric bellows 20 to 350 ml ($\pm 10\%$)

At ambient temperature of 20°C (+/-10%) and ambient atmosphere of 101.3 kPa (+/-10%).

Minute Volume 0 to 30 L

Rate 4 - 100 bpm

I:E Ratio 1:0.3 - 1:8

Pressure Limit 10 - 80 cmH₂O

Fresh Gas Compensation Automatic Tidal Volume adjustment

Modes

Off

Standby

Volume Cycle

Pressure Controlled

Spontaneous (includes advanced Pressure Support Ventilation)

Pressure Control 10 - 70 cmH₂O

Inspiratory Flow 2 - 75 L/min

Spontaneous Mode Active Volume and Pressure Alarms,
Advanced Breathing Mode selectable (see section 4.6)

Electronic PEEP 4 - 30 cmH₂O

Oxygen Monitor Fuel Cell type
For full specification, see section 4.15.

Spirometry - Resolution ± 1 ml

Ventilator Performance - accuracy of delivered volumes

>300 ml $\pm 10\%$

>100 ml <300 ml $\pm 20\%$

<100 ml $\pm 50\%$.

NOTE

The ventilator is designed for use with Spirometry ON.

Accuracy of delivered volumes with Spirometry OFF may vary from the figures given above.

SPECIFICATION

4.6 Advanced Spontaneous Breathing Mode (PSV)

Trigger (PEEP Referenced)	0.2 to 4 L/min
Trigger Window	Set 60% of Expiratory Time
Vt and Vm	As Volume Mode
Insp Time (Ti)	0.5 to 5 secs
Support Pressure	3 to 20 cmH2O

Default settings

Volume	Vt	BPM	I:E	Pmax
Adult	600 ml	10	1:2	38 cmH2O
Paediatric	150 ml	15	1:2	38 cmH2O

Pressure	Vt	BPM	I:E	P-target
Adult	600 ml	10	1:2	10 cmH2O
Paediatric	150 ml	15	1:2	10 cmH2O

PSV	Support Pressure	Insp time
Adult	10 cmH2O	0.4 L/min
Paediatric	10 cmH2O	0.4 L/min

4.7	Disinfection and Sterilisation	Bellows base assembly, Patient Block assembly and inside of bellows can be sterilised if necessary - section 6.
4.8	Bacterial Filter	None (see section 5.1.4, use a bacterial filter in the breathing system to protect components that are not autoclavable, e.g. oxygen sensor)
4.9	Fail Safe Mechanism	Battery back-up in case of mains electricity failure Gas shut-off in the event of electronic failure
4.10	Reliability	MTBF: 5×10^6 to 50×10^6 cycles
4.11	Waveform Tests	Not applicable
4.12	Volume Tests	Not applicable
4.13	Mobility and Mounting	
	(A) Mobility	Secure mounting required.
	(B) Mounting	Control unit and remote screen are mounted on anaesthetic machine. The bellows assembly is built into the A200SP Absorber.
4.14	Fuse (mains supply)	Two fuses, Type T 2AH 2 A, 250 V rating, 20 mm, anti surge, ceramic.

SPECIFICATION - O₂ Monitor

4.15 Oxygen Monitor

Measurement Range:	0-100%
Resolution:	±1%
Accuracy and Linearity:	±2% of full scale (at constant temperature and pressure)
Response Time:	90% of final value in approx. 10 seconds (air to 100% O ₂)
Operating Temperature:	50°F to 100°F (10°C to 38°C)
Storage Temperature:	23°F to 122°F (-5°C to 50°C)
Relative Humidity Range:	5%-95% (non-condensing)
Battery Back-up:	As per ventilator
Sensor Type:	MOX-3 galvanic fuel cell
High Priority Alarm:	Flashing, 5 audio pulses with 6 seconds repeat time.
Medium Priority Alarm:	Flashing, 3 audio pulses with 24 seconds repeat time
Low Priority Alarm:	Static with single beep sound
Alarm Mute:	30 seconds for high priority alarm 120 seconds for medium priority alarm
Low Alarm Set Range:	18%-99% (± 1%)
High Alarm Set Range:	19%-105% (± 1%)
Cable length:	2 m (6 ft), fully extended

Sensor

Type:	Galvanic fuel cell sensor (0-100%)
Life:	1500000 O ₂ % hours (One year minimum in typical applications)

Interference Gases and Vapours (in 30% Oxygen, 70% Nitrous Oxide)

<i>Interference</i>	<i>Volume % Dry</i>	<i>Interference in O₂%</i>
<i>Nitrous Oxide</i>	80%	<1%
<i>Carbon Dioxide</i>	5%	<1%
<i>Halothane</i>	5%	<1%
<i>Enflurane</i>	5%	<1%
<i>Isoflurane</i>	5%	<1%
<i>Sevoflurane</i>	5%	<1%

SPECIFICATION - O₂ Monitor

Oxygen Monitor - continued

Humidity Effects

Sensor output is relatively unaffected by prolonged operation in either high or very low relative humidity.

If the sensor shows signs of being affected by condensation, dry the sensor with soft tissue.

CAUTION *DO NOT use heat to dry the sensor.*

Temperature Effects

The sensor has a built-in temperature compensation circuit, and is relatively unaffected by temperature changes within the operating temperature range given above.

Pressure Effects

The sensor measures O₂ partial pressure, and its output will rise and fall due to pressure change (e.g. changes in barometric pressure, or breathing system pressure).

An increase in pressure of 10% at the sensor inlet will produce a 10% increase in sensor output.

5. PRE-OPERATION PROCEDURES

5.1 Ventilator Set-up

5.1.1 Mounting the Ventilator

The remote screen is mounted on an adjustable arm, with the control unit mounted at the rear or side of the anaesthetic machine.

Optional mounting:

To fit the ventilator control unit permanently on a mounting bracket:

1. Align the four mounting feet over the mating holes in the bracket.
2. Use the four M4 screws supplied with the mounting bracket kit, inserted through the bracket and rubber feet and screwed into the threaded inserts in the base of the ventilator.

Only use the screws supplied with the kit.

Pole-mount type mounting brackets and side frame brackets are available from the manufacturer.

Bellows unit

The bellows unit is built into the A200SP absorber.

5.1.2 Electrical Power Connection

Before connecting the ventilator to the mains supply, check that the power supply is within the correct rating as stated on the label on the rear of the control unit.

WARNING

Excessive electronic noise caused by other, poorly regulated devices, such as electrocautery, may adversely interfere with the proper functioning of the ventilator.

To avoid this problem, do not connect the ventilator power cord into the same electrical wall outlet or strip into which an electrocautery unit is connected.

5.1.3 Ventilator Gas Supply

1. Verify the drive gas specified for the ventilator (oxygen or air).
Always use the correct drive gas.
2. Connect the drive gas inlet port on the rear of the control unit to a dry, oil free supply.

Supply pressure range:

45 to 100 psi
(3.1-6.9 bar, 310-689 kPa)

OXYGEN SUPPLY:

- a) O₂ cylinder,
- b) Anaesthetic machine O₂ auxiliary gas outlet,
- c) O₂ pipeline supply from a wall outlet.

AIR SUPPLY:

- a) Air cylinder,
- b) Anaesthetic machine Air auxiliary gas outlet
- c) Air pipeline supply from a wall outlet.

Supply pressure should be monitored by a separate means, e.g. pressure gauge on anaesthetic machine or supply line.

NOTE: It is possible to reconfigure the ventilator for use with a different drive gas to the gas originally specified. This work must be carried out by an engineer trained by the manufacturer.

5.1.4 Breathing System Schematic

The following page contains a schematic diagram showing the cables and tubing for an AV-S ventilator mounted on a Prima SP2 anaesthetic machine with an integral A200SP Absorber.

PRE-OPERATION PROCEDURES

Hoses and Cables Schematic AV-S and A200SP Absorber

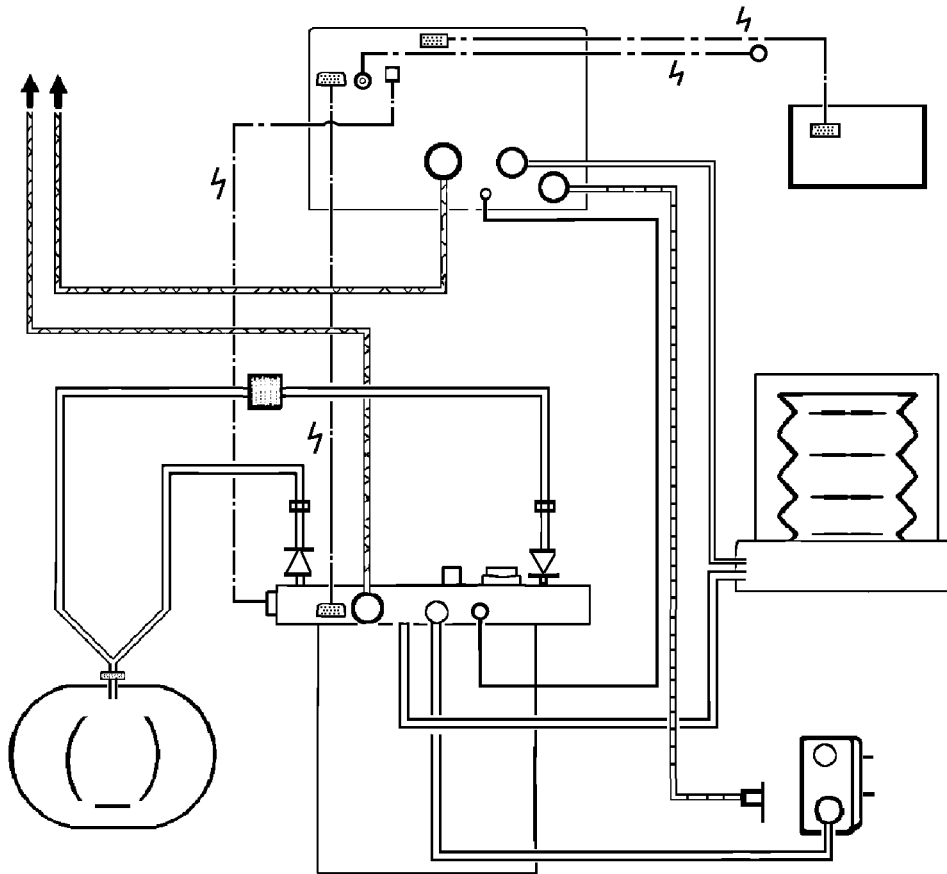

Note

1. AV-S has spirometry and oxygen monitor.
2. Interface cabling is shown for Prima SP2 On/Off switch and A200SP Bag/Vent switch.

PRE-OPERATION PROCEDURES

1. Bellows
2. Ventilator Control Unit
3. Outlets to Anaesthetic Gas Scavenging System (AGSS)
4. Bacterial Filter
5. Absorber valve block
6. Heat and moisture exchanger
7. Patient
8. CGO Block on anaesthetic machine (Fresh Gas Supply)
9. Auxiliary Outlet on anaesthetic machine (Drive Gas Supply)
10. Flow sensor - expiratory
11. Flow sensor - inspiratory
12. Connectors - sensor - pressure monitor
13. Expiratory Valve - Absorber
14. Inspiratory Valve - Absorber
15. Inlet - from Ventilator Bellows
16. Connector - Reservoir Bag
17. Inlet - Absorber - Fresh Gas Supply
18. Drive Gas Inlet - Ventilator
19. Drive gas Outlet - ventilator control unit to bellows
20. Outlet - Exhaust Valve
21. Inlet - Bellows Drive Gas
22. Outlet - to breathing system
23. Input socket - Oxygen monitor sensor
24. Input socket - Prima SP interface
(SP on/off switch)
25. Input socket:
 - (i) A200SP Absorber Bag/Vent control position
 - (ii) Spirometer sensor signal
26. Interface connections on Prima SP2 and A200SP
27. APL Valve
28. Outlet from APL Valve to AGSS
29. Oxygen sensor
30. Remote mounted display screen
31. Cable (control unit to screen)

PRE-OPERATION PROCEDURES

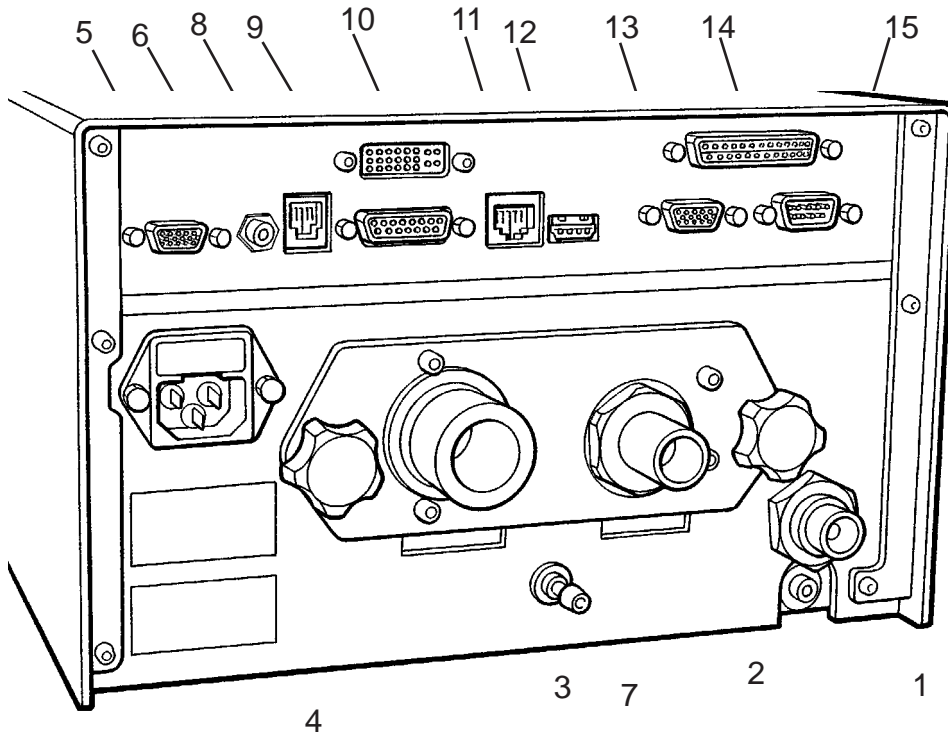

Control Unit Rear Panel

Gas Connections

1. Ventilator drive gas inlet
- connect to anaesthetic machine
auxiliary gas outlet
2. Bellows Drive Gas Output
- connect to bellows
(on Prima SP2 with A200SP absorber,
connect to absorber - see section 5.1.5)
3. Outlet - Exhaust Valve

Electrical Connection

4. Electrical mains input and fuse unit

Interface and Parameter inputs

5. A200SP Absorber Bag/Vent
switch interface
Spirometer connector
6. Prima SP2 Interface connector
7. Pressure Monitor Port
8. Input socket - Oxygen monitor
sensor

Data and Printer Ports

9. Data Output
10. Output to remote display
11. Ethernet
12. USB
13. VGA
14. Printer port
15. RS232

NOTE

USB port is for access only by engineers
trained by the manufacturer.
All other data ports are read only.
For further information, please contact
Paragon.

PRE-OPERATION PROCEDURES

5.1.5 Bellows drive gas hose

1. Prima SP2 with A200SP absorber: Connect a 16 mm diameter corrugated hose between the ventilator control unit drive gas outlet (labelled: DRIVE GAS) and the outlet (1) at the rear of the A200SP absorber.
2. All other AV-S configurations: Connect a 16 mm diameter corrugated hose between the control unit drive gas outlet (labelled: DRIVE GAS) and the bellows base DRIVE GAS inlet port.

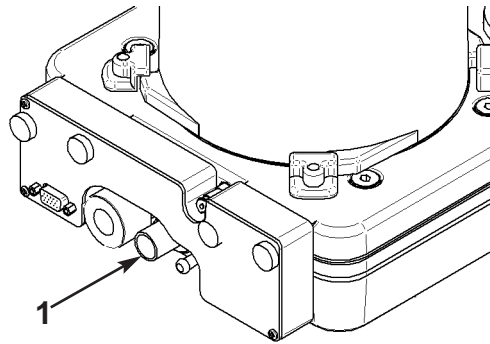

5.1.6 Anaesthetic Gas Scavenging System

1. Connect the EXHAUST valve port on the control unit to a properly functioning scavenging system
Use a 19 mm hose.
2. Fit a 10 cmH₂O pressure relief valve between the exhaust valve port and the inlet port of the AGSS receiver.
Note that the diaphragm valve under the bellows is connected internally to the EXHAUST port to facilitate the discharge of excess breathing gas at the end the expiratory phase.

WARNING

Do not use a scavenging system that restricts drive gas flow when negative pressure is exerted on it. Applying negative or positive pressure to the bellows exhaust port results in positive pressure in the patient breathing system.

Therefore, the scavenging system must not generate more than 0.5 cmH₂O positive or negative pressure when connected to the ventilator.

Any problem arising from an improperly functioning scavenging system is solely the user's responsibility.

5.1.7 Remote Screen

Attach the DVI cable supplied with the screen between the interface connectors (1) on the rear of the control unit and screen.

WARNING

Check that the cable between the control unit and remote display screen unit is securely connected before use.

Always use a cable type recommended by the manufacturer.

5.1.8 Printer

Attach a printer to the printer port (2) if a printed output of the ventilator function is required.

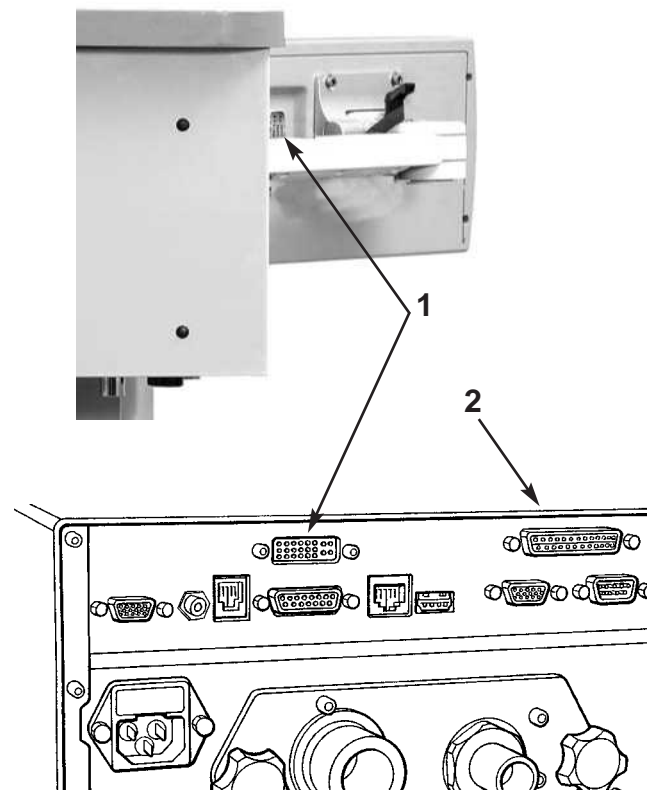

PRE-OPERATION PROCEDURES

5.1.9 Breathing System

1. Connect the ventilator bellows base BREATHING SYSTEM port to the breathing system.
2.
 - a) Use a breathing system bacterial filter in the expiratory limb of the breathing circuit to protect the oxygen sensor.
 - b) Use a heat and moisture exchanger (HME) at the patient Y piece.

CAUTION

Replacement/Disposal - always follow the instructions supplied with the filter or HME.

Fit new components at the recommended interval.

3. Connect a 2-litre breathing bag to the patient connection as a test lung.
4. Close the anaesthetic machine APL valve.

5.1.10 Spirometer

5.1.10.1 Flow sensors fitted to an A200SP Absorber mounted on a PrimaSP2

1. Use a breathing system bacterial filter - see section 5.1.9, operation 2.

CAUTION

Replacement/Disposal - always follow the instructions supplied with the filter.

Always renew components at the recommended interval.

2. The two spirometry flow sensors are mounted within the A200SP Absorber in the inspiratory and expiratory airways.
3. Connect the cable assembly between the connector at the rear of the A200SP Absorber (A) and the socket (B) at the rear of the Ventilator control unit.
4. Check that the cable connections are secure.

NOTE

- A) *If the connections are incorrectly made, the ventilator will alarm LOW TIDAL VOLUME or HIGH TIDAL VOLUME.*
- B) *To allow the ventilator to be used in the event of damage, or non-functioning of the spirometer heads, turn off the spirometry function - see MENU function, section 3.5.*

If the spirometer is switched OFF:

- a) *Fresh gas compensation is disabled*
- b) *Fresh gas mixture compensation is disabled.*
- c) *Patient support function is disabled.*

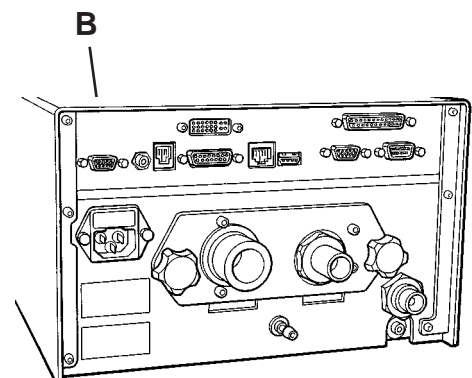
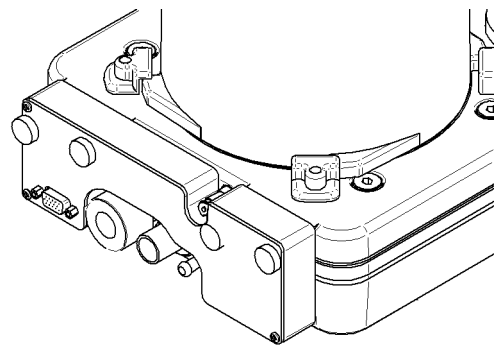

PRE-OPERATION PROCEDURES

5.1.10.2 Spirometer Calibration

Flow sensors fitted to an A200SP Absorber mounted on a Prima SP2

The Spirometry heads must be calibrated with zero flow going through them.

1. Turn the Prima SP gas flow off at the Gas Delivery on/off switch. This will stop all gas flows (including the AHD basal flow). This will also turn the AV-S off.
2. Turn the AV-S on at the ventilator (Do not use the Prima SP Gas Delivery switch).
or,
Disconnect the fresh gas hose from the CGO block on the anaesthetic machine.
3. Remove the breathing circuit hoses from the inspiratory and expiratory connectors (1) on the absorber.
4. Disconnect the hose that connects the APL valve outlet (2) at the rear of the manifold block to the AGSS receiver (or disconnect at receiver).
5. a) Remove the bag, and set the Bag/Vent control (3) to Bag position.
or,
b) Ensure that the ventilator bellows is empty,
6. Calibrate the spirometer via the ventilator menu procedure.
7. Press the menu switch on the front panel.
8. Scroll down the main menu and select O2 MONITOR & SPIROMETRY.
9. Select SPIRO CALIBRATION.
10. Press the wheel to initiate calibration.
11. Calibration is completed.
12. Scroll to ESCAPE FROM MENUS.
13. Press the wheel to confirm.

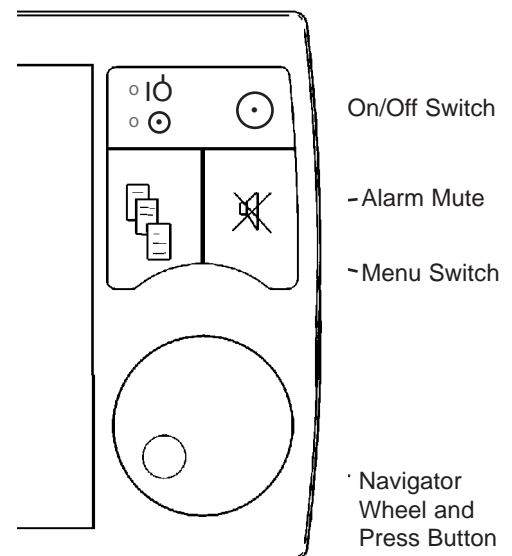
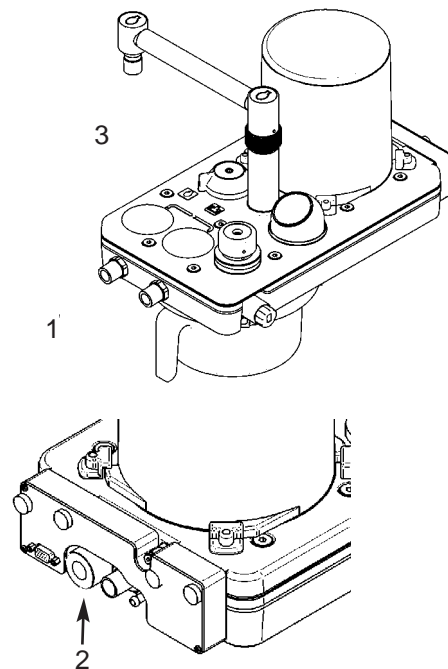

O2 Monitor & Spiro

```

ESCAPE FROM MENU
O2 MONITOR: on
CALIBRATION: 100%
HIGH ALARM SET: 105
LOW ALARM SET: 18
SPIROMETER: on
> SPIRO CALIBRATION: 0 L/min
    
```

PRE-OPERATION PROCEDURES

5.1.11 Pressure Monitor Connections

WARNING

The High and Low Airway Pressure Alarms are important for patient care.

The connection point must be properly located in the expiratory limb of the breathing system.

1. PATIENT PRESSURE port (A) on the rear panel of the control unit:
Use the tubing assembly supplied by the manufacturer to connect to the expiratory limb of the breathing system, close to the circle system expiratory valve.

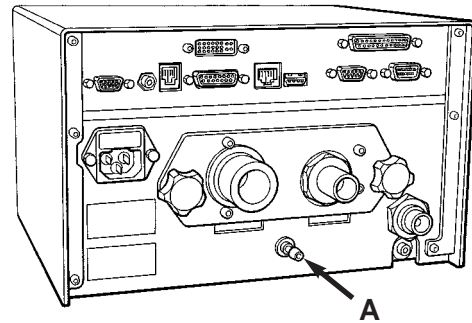

2. Push-fit, self sealing connectors (B)
Push in the tube as far as possible
Do not use excessive force.

The connector end piece 'X' will also move inwards.

Pull the tube carefully outwards.
The end piece 'X' will be pulled outwards to the 'locked' position.

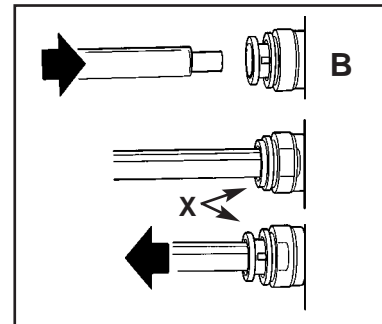

3. Connect the tubing (with adaptor, Part No 053049) to the push-fit, self-sealing connector (C) at the rear of the A200SP Absorber.

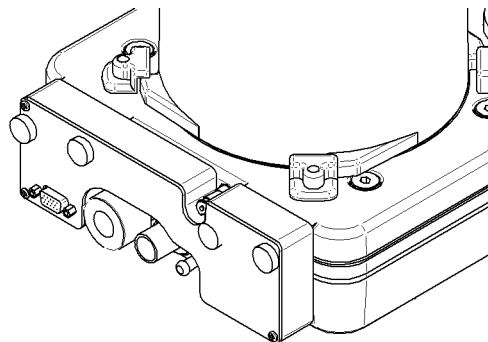

PRE-OPERATION PROCEDURES

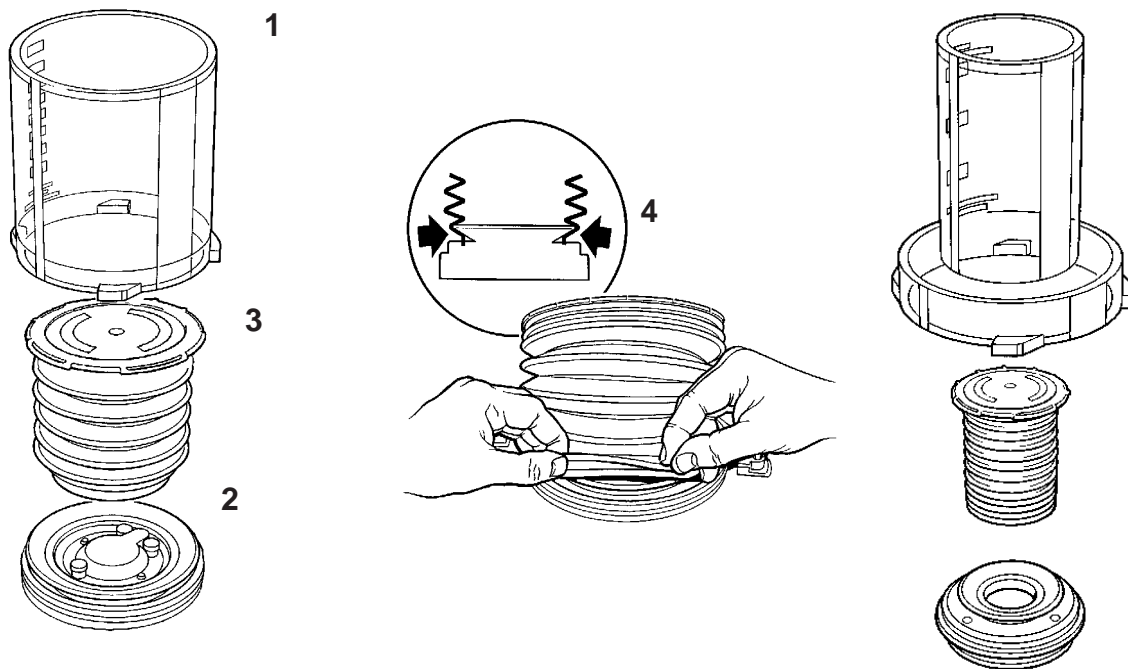

5.1.12 Bellows Assemblies

CAUTION

Always ensure correct fitment of bellows (see illustration above), and carry out a full function test before clinical use, if a bellows is removed and refitted.

1. Remove the bellows housing (1). Twist carefully counterclockwise until the bayonet tabs become free, then lift up from the base (2).
2. Remove the bellows (3).
3. Refit the bellows and check for correct assembly, as illustrated (4).
4. Fit the bellows housing by pushing down, then twisting clockwise until the bayonet tabs completely engage.
5. Function test the ventilator - section 5.3.1.

NOTE

If there is any malfunction, the ventilator must NOT be used.

If the problem cannot be rectified, the ventilator must be checked by an engineer trained by the manufacturer.

Paediatric Bellows Assembly

1. Remove the adult bellows housing (1) - twist carefully counterclockwise until the bayonet tabs become free, then lift up from the base (2). Remove the bellows (3).
2. Fit the paediatric adaptor (5) - press the adaptor into the ventilator bellows assembly base (2).
3. Fit the paediatric bellows (6) to the adaptor. Check for correct assembly, as illustrated (4).
4. Fit the paediatric bellows housing (7) to the base by pushing down, then twisting clockwise until the bayonet tabs completely engage.
5. Function test the ventilator - section 5.3.1.

PRE-OPERATION PROCEDURES

5.2 Pre-use Checklist

5.2.1 Daily Checklist

The following tests must be carried out at the beginning of every working day:

Alarm System

WARNING

The operation of each alarm function should be verified daily.

If the audible alarm or the visual display for any alarm function fails to activate during any alarm condition or fails to reset after the alarm has been cleared, refer the unit to an authorised service technician.

Back-up Battery

WARNING

If the internal battery is fully discharged, the ventilator will not function.

Recharge the battery before the ventilator is used clinically.

Charging the battery for 14 hours from a discharged state will allow a minimum of 30 minutes of continuous operation.

Connect the ventilator to a mains power supply. The mains power indicator will illuminate to show that the battery is being charged (it is not necessary to turn on the ventilator).

Ventilator internal test

Press the ON/OFF switch (1).

A three-second internal test is initiated:

1. The 'power -up' screen is displayed.
2. The audible alarm sounds.
3. The ventilator reverts to STANDBY mode if no selection is made.

NOTE special operating system on ventilators interfaced with Prima SP2 (see section 3.5.2).

- a) Turn the anaesthetic machine Gas Delivery Switch to ON - the ventilator will power-up.
- b) While machine power is ON, the Ventilator can be turned OFF and ON, using the ventilator On/Off switch.
- c) Turn the machine Gas Delivery Switch to OFF. The ventilator will power-down.

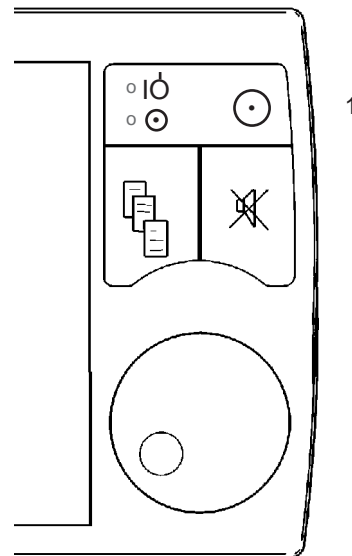

Calibrate the Spirometer - 5.1.9.2

Calibrate the O2 Monitor - 5.3.2

PRE-OPERATION PROCEDURES

Function Test

1. Set the AIRWAY PRESSURE LIMIT to 50 cmH₂O.
2. PRESSURE TRANSDUCER connection
Check that the port on the rear of the control unit is correctly connected to the port on the rear of the absorber assembly (see section 5.1.10).
3. Connect a 2-litre breathing bag to the patient connection as a test lung.
4. Adult bellows only:
Set the tidal VOLUME to 600 ml; RATE to 10 bpm, and I:E RATIO to 1:2.0.
5. Use the O₂ flush button on the anaesthetic machine to fill the bellows.
6. Select VOLUME CYCLE mode.
7. The delivered tidal volume indicated on the scale printed on the bellows housing should be approximately 600 ml.
If the delivered tidal volume is less than 500 ml or greater than 700 ml, refer the ventilator to an engineer trained by the manufacturer.
8. Set a basal flow only on the anaesthetic machine.
Check the bellows after 10 breaths - the bellows should return to the top of the housing.
Failure to return to the top of the housing indicates a leak in the breathing circuit.
Rectify the leak before clinical use.
9. Occlude the patient 'Y' -piece.
The HIGH AIRWAY PRESSURE alarm should be activated.
The peak pressure read on the breathing system pressure gauge is the maximum working airway pressure limit and should agree with the setting.
10. Open the patient 'Y' -piece to ambient pressure.
At the second cycle, the LOW AIRWAY PRESSURE alarm should be activated.
11. Select STANDBY mode
Before using the ventilator clinically, check that all connections are correct, and verify that there are no leaks.

NOTE

If there is any malfunction, the ventilator must NOT be used.

If the problem cannot be rectified, the ventilator must be checked by an engineer trained by the manufacturer.

PRE-OPERATION PROCEDURES

5.2.3 Weekly Checklist

At least every week, in addition to the daily function test, the following checks must be carried out:

Alarms

1. Select STANDBY MODE.
2. Unplug the mains power cable from the AC outlet.
The MAINS FAILURE alarm should activate.
3. Reconnect the mains power cable to the AC outlet. The alarm should turn off.
4. Disconnect the drive gas supply hose.
The LOW SUPPLY PRESSURE alarm should activate.

NOTE

If there is any malfunction, the ventilator must NOT be used.

If the problem cannot be rectified, the ventilator must be checked by an engineer trained by the manufacturer.

Bellows

Check the condition of the bellows and exhalation diaphragm valve - see section 6.2.2.

PRE-OPERATION PROCEDURES - O₂ Monitor

5.3 O₂ Monitor System Set-up

5.3.1 Installation

Fit the probe (A) to the A200SP absorber. Connect the cable to the input socket (B) on the back of the AV-S ventilator control unit

NOTE The anaesthetic machine gas control switch must be in the ON position for gas delivery.

WARNING

The sensor contains a small quantity of electrolyte, classified as a harmful irritant which is potentially hazardous.

Do not attempt to open a cell.

ALWAYS check the integrity of the sensor assembly before use.

Once exhausted, the sensor must be disposed of according to hospital, local, state and federal regulations.

NOTE

To maintain maximum sensor life:

i) always disconnect the breathing circuit after use.

ii) Switch off the anaesthetic machine to cut-off the basal flow through the system.

Bacterial Filter

Use a breathing system bacterial filter in the expiratory limb of the breathing circuit to protect the oxygen sensor (see section 5.1.8).

CAUTION

Replacement/Disposal - always follow the instructions supplied with the filter, and always replace at the recommended interval.

5.3.2 Calibration

The new unit must be calibrated before clinical use.

Thereafter, as a safety precaution, we recommend calibration of the unit every time the system is switched on.

Calibration must also be performed:

- A) when the sensor is replaced
- B) when point-of-use elevation changes by more than 160 m (500 ft).

We recommend calibration with a 100% oxygen standard source, at a pressure and flow similar to your application.

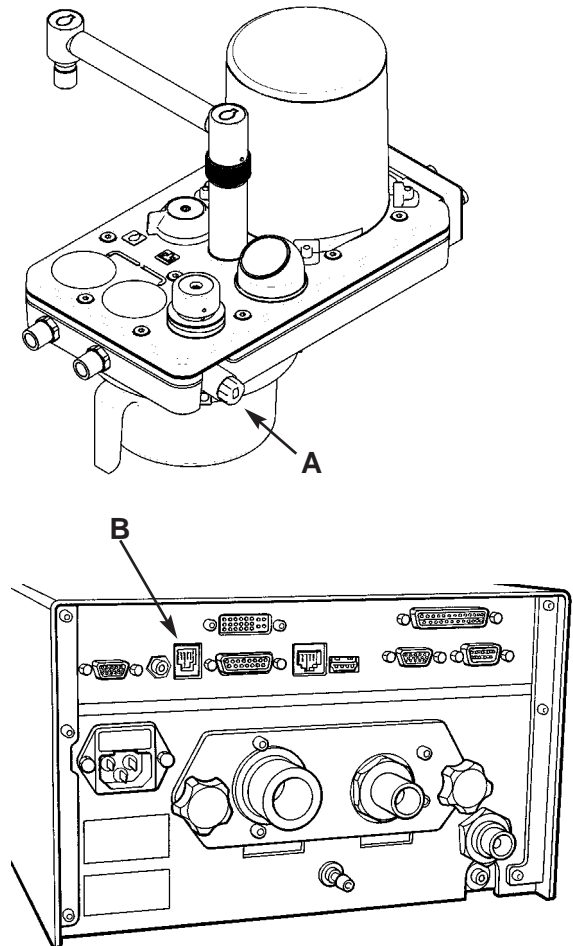

PRE-OPERATION PROCEDURES - O₂ Monitor

5.3.2.1 Calibration - Using 100% Oxygen

AV-S ventilator mounted on a Prima SP2 anaesthetic machine fitted with a A200SP absorber

Calibrate with the sensor in position within the absorber.

1. Detach the absorbent canister (1).
2. Remove the breathing circuit hoses from the inspiratory and expiratory connectors (2) on the absorber.
This will give a free flow of oxygen through the sensor.
3. Switch on the ventilator (3) and the anaesthetic machine gas delivery switch.
The oxygen monitor automatically switches ON when the ventilator is switched on.
Ensure that all vaporizers are OFF.
4. Apply 100% oxygen only, at 5 L/min, from the anaesthetic machine flowmeter.
5. Allow the oxygen to flow until the oxygen monitor readout (4) stabilises.
6. Calibrate the sensor, using the AV-S ventilator menu procedure, as follows.
7. Press the menu switch (5) and select the O₂ monitor sub-menu.
8. Scroll to CALIBRATION.
If the menu shows 21% (which indicates calibration using air), press the navigator wheel / button (6) to switch to 100% (calibration using oxygen).
9. A message will flash on the screen:
O₂ AT 100% ?
Press the button (5) to confirm
NOTE
The message:
OXYGEN SENSOR LOW OUTPUT
will appear on screen if the user attempts to calibrate at 21% in 100% oxygen.
10. Scroll to ESCAPE FROM MENUS and press the button (6) to exit.
11. Turn off the flow of oxygen.
12. Refit the absorbent canister (1).

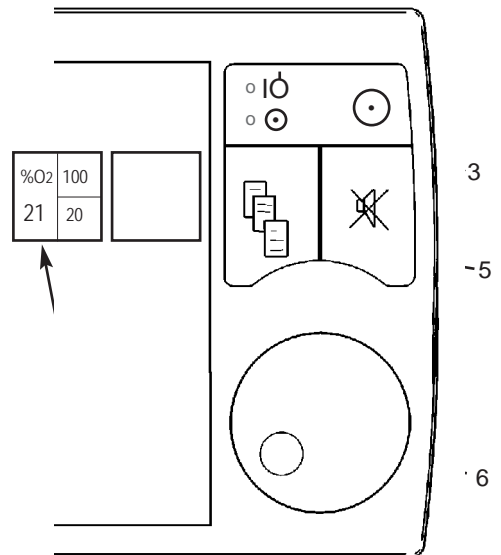
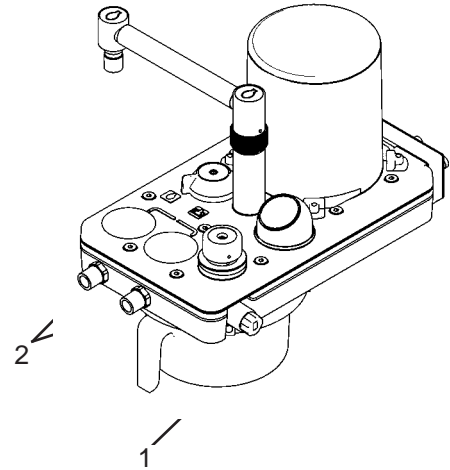

O ₂ Monitor & Spiro	
ESCAPE FROM MENU	
O ₂ MONITOR: on	
>	CALIBRATION: 100%
	HIGH ALARM SET: 105
	LOW ALARM SET: 18
	SPIROMETER: on
	SPIRO CALIBRATION: 0 L/min

PRE-OPERATION PROCEDURES - O₂ Monitor

5.3.3 Sensor Low Indication

The unit automatically detects when sensor life is low.

The message:

OXYGEN SENSOR LOW OUTPUT will appear on screen to indicate that the sensor must be replaced.

The sensor output will fall very quickly to zero over a period of two to three weeks from the first time that the alarm is activated.

Sensor replacement - see section 6.5.

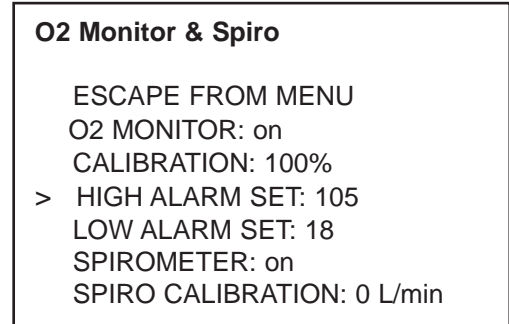

5.3.4 Setting the O₂ Alarms

5.3.4.1 Set High Alarm

The high alarm value cannot be set below 19% or above 105% (Note that in certain conditions of excess pressure, the readout may show a value above 100%).

1. Touch the O₂ concentration display, or Press the menu switch on the ventilator front panel and select the O₂ monitor sub-menu.
2. Scroll to HIGH ALARM SET and press the navigator wheel.
3. Rotate the wheel to change the displayed alarm figure to the desired value.
4. Press the wheel to confirm.
5. Scroll to ESCAPE FROM MENUS and press the wheel to exit.

5.3.4.2 Set Low Alarm

The low alarm value cannot be set lower than 18%, or above 99%.

1. Touch the O₂ concentration display, or Press the menu switch on the ventilator front panel and select the O₂ monitor sub-menu.
2. Scroll to LOW ALARM SET and press the navigator wheel.
3. Rotate the wheel to change the displayed alarm figure to the desired value.
4. Press the wheel to confirm.
5. Scroll to ESCAPE FROM MENUS and press the wheel to exit.

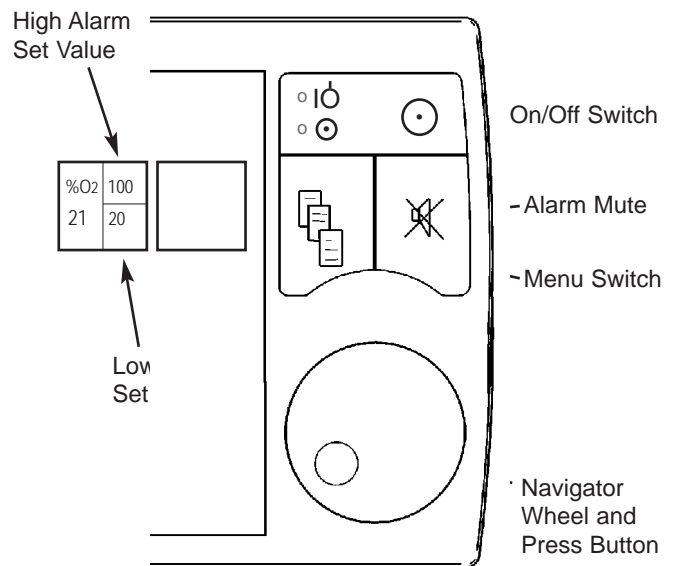

6. USER MAINTENANCE

6.1 Service Schedule

At 6 months, 12 months, 2 years and 4 years, the ventilator must be serviced by an engineer trained by the manufacturer, following the schedule given below, and the procedures given in the AV-S Service Manual.

Every day:

Pre-use function check

Every week:

Check the condition of the bellows assembly diaphragm valve, and clean as required.

Test the Mains Failure Alarm and the Low Supply Pressure Alarm

Every 6 months:

Inspection and Function Check.
Remove patient block assembly and clean.
Check condition of bellows.

Every 12 months:

Repeat six month procedure, plus:
Replace O-seals and drive gas inlet filter.
Replace exhaust diaphragm valve
Preventive maintenance kit available.

Every 2 years:

Repeat 12 month service, plus:
Replace 12v battery.

Every 4 years:

Repeat 2 year service, plus:
Replace PCB battery.
Replace bellows diaphragm valve

Details of these service operations are given in the Service Manual.

Always ensure that a record is kept of any service or repair work.

6.2 Cleaning

6.2.1 Outside surfaces and bellows housing

CAUTION

Care must be taken not to allow liquids to run into the control unit; serious damage may result.

Check that the unit is disconnected from the electrical supply before cleaning.

Do not use cleaning solutions containing alcohol; the bellows housing may be damaged.

To clean the outside surfaces of the ventilator units and cables, use a damp cloth (screen - see below).

If necessary use a warm, mild detergent solution to remove resistant grime. Make sure that all detergent residues are fully removed after cleaning.

Never use any harsh abrasive cleaning agent. The transparent acrylic bellows housing and, in general, the surfaces of the control unit are not scratch resistant.

The inside of the bellows housing, under normal conditions, is not in contact with the breathing gas and therefore only needs cleaning as described above.

Remove the bellows housing (A) by slightly twisting it counter-clockwise until the tabs at the bottom clear the bayonet locks, then lift it straight up from the base.

Touchscreen

Use a soft cloth only.

Never use any harsh abrasive cleaning agent.

USER MAINTENANCE

6.2.2 Bellows and exhalation diaphragm valve

Each time the bellows assemblies are opened for cleaning, all visible components must be carefully inspected and damaged parts must be replaced.

Bellows

As with all elastomers, the bellows material deteriorates with aging and should be inspected at least every six months or after 1200 hours of use, whichever comes first. The bellows must be replaced if it shows signs of aging.

The bellows (B) can be removed by carefully pulling it off the base. If a paediatric bellows is fitted, the bellows adaptor (C) must also be removed.

Do not dismantle the bellows.

Exhalation Diaphragm Valve

The exhalation diaphragm valve is under the bellows and can be removed by loosening the three thumbscrews. The valve seat is now visible.

WARNING

Great care must be taken. Do not damage the precision surface of the valve seat (D). Never use any hard object or abrasive agent to clean it; use only a soft cloth. If the valve seat is damaged, the diaphragm valve will leak and may cause serious malfunction.

Clean the seat, and the metal disk (E) attached to the base of the diaphragm valve, thoroughly and remove all contamination from the surfaces of both components.

NOTE

If excessive contamination is discovered, check that a bacterial filter is used in the expiratory limb of the breathing circuit (and an HME at the patient tee-piece).

After cleaning, check that the small O-ring (F) located in the bellows base under the diaphragm valve is in place. The ventilator will not function if the O-ring is missing.

See section 6.5 for information on sterilisation procedures.

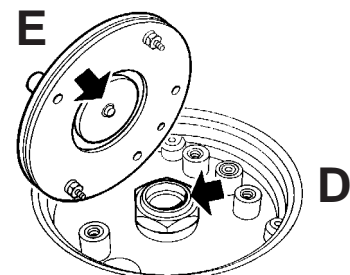
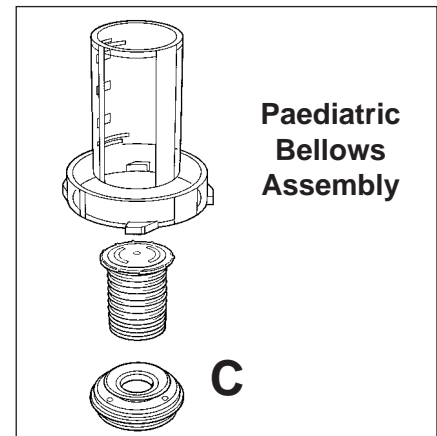
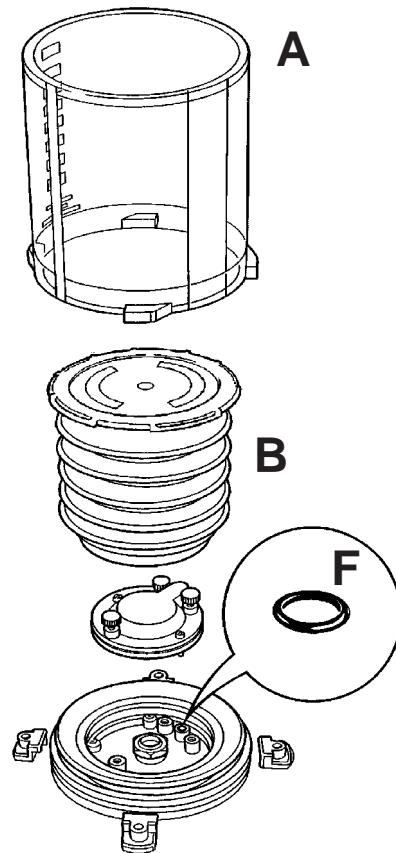

USER MAINTENANCE

Refitting

Refit the diaphragm valve assembly to the bellows base and reassemble the bellows assembly (see section 5.2).

If a paediatric bellows is fitted, press the adaptor (C) into the ventilator bellows assembly base, then fit the bellows.

CAUTION

Always check for correct fitment of the bellows (see illustration), and function test the ventilator before clinical use.

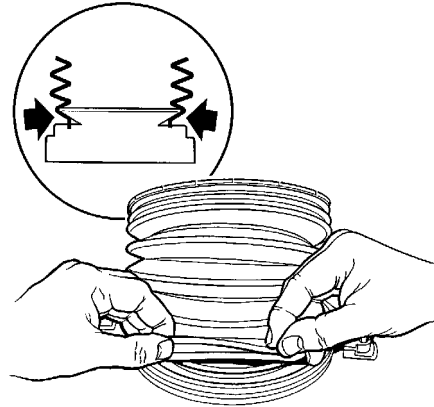

6.2.3 Spirometer Sensors

The sensors are built into the A200SP absorber, and cleaning and sterilisation can only be carried out when the absorber assembly is removed for cleaning.

For further information please refer to the user instructions supplied with the A200SP.

USER MAINTENANCE

6.2.4 Control Unit Patient Block Assembly

On a regular basis (in line with hospital procedures for infection control), the patient block (1) must be removed, cleaned and sterilised.

1. Detach the hoses from the outlets (2).
Note different diameters for correct refitment.
2. Undo the securing knobs (3).
3. Carefully detach the assembly (1) from the control unit.
Note that resistance will be felt until the metal tubes (4) disengage.
4. Wash thoroughly, then sterilise, as recommended in section 6.3.
Do not disassemble.

Refitting

5. Position the patient block and push fully into the control unit, ensuring that the metal tubes (4) are engaged in their unions.
6. Fit the securing knobs (3).
7. Function test the ventilator.

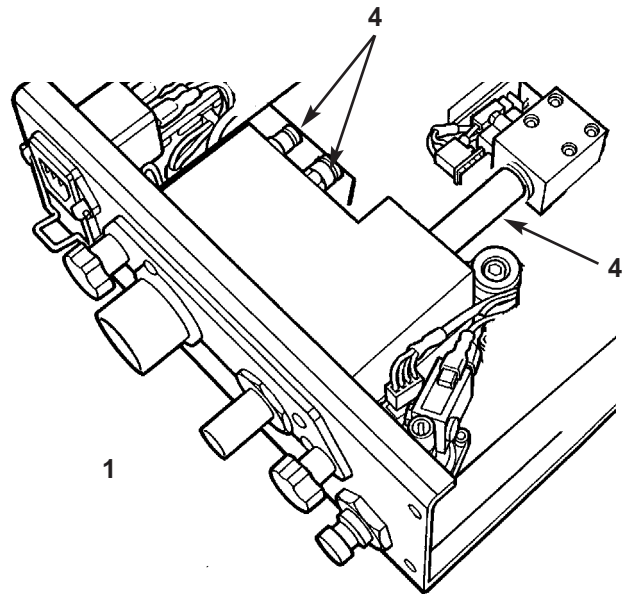
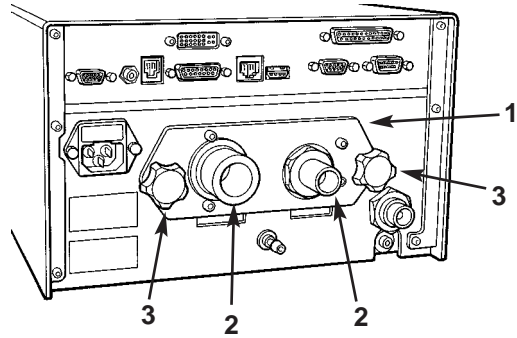

USER MAINTENANCE

6.3 Sterilisation

Recommended guidelines for sterilisation

CAUTION

To prevent possible damage to components, peak sterilisation temperatures must not exceed :

54°C (130°F) for gas (ethylene oxide) or,
134°C (275°F) for steam autoclave.

Note low temperature autoclave is 121°C .

Do not sterilise the ventilator control unit. The internal components are not compatible with sterilisation techniques and may be damaged.

Following sterilisation with ethylene oxide, components must be quarantined in a well ventilated area to allow dissipation of any residual gases.

Follow the recommendations given by the steriliser manufacturer for aeration periods required.

ITEM	METHOD
Bellows	Gas, liquid, autoclave (20 cycles max.)
Hoses	Gas, liquid, autoclave
O rings	Gas, liquid, autoclave
Bellows base	Gas, liquid, autoclave
Exhalation valve assembly	Gas, liquid, pasteurise, low temperature autoclave
Control unit	Do not sterilise - remove patient block
Patient Block	Autoclave
Bellows canister	Liquid, autoclave

Oxygen monitor (including sensor) - see section 6.4

NOTE

1. Liquid method indicates the use of a high level disinfectant.
2. Examples of suitable high level disinfection liquid agents are: Nu-Cidex, Sporicidin, and Sonacide.
3. The exhalation diaphragm valve must be removed, cleaned and sterilised separately.

USER MAINTENANCE

6.4 Oxygen Monitor Sensor - Cleaning / Disinfection / Sterilisation

In case of contamination the sensor may be cleaned with distilled water and allowed to dry naturally.

CAUTION

The sensor is not suitable for sterilisation by steam or exposure to chemicals such as ethylene oxide or hydrogen peroxide.

Do **not** immerse the sensor in any cleaning solution.

Do **not** autoclave or expose the sensor to high temperatures.

Bacterial Filter

Use a breathing system bacterial filter in the expiratory limb of the breathing circuit to protect the oxygen sensor (see section 5.1.8).

CAUTION

Replacement/Disposal - always follow the instructions supplied with the filter, and always replace at the recommended interval.

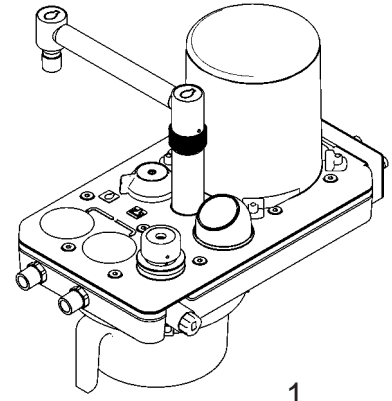

6.5 Oxygen Sensor Replacement

WARNING

The sensor (1) contains:

A) A small quantity of electrolyte, classified as a harmful irritant which is potentially hazardous.

B) Lead

Do not attempt to open a cell.

ALWAYS check the integrity of the sensor assembly before use.

Once exhausted, the sensor must be disposed of according to hospital, local, state and federal regulations.

6.5.1 Sensor Expiry Date

The approximate expiry date is marked on the sensor label, using two boxes which represent the year and month.

Thus, on a sensor marked as below the approximate expiry date is the end of December 2006.

YR	0	1	2	3	4	5	X	7	8	9		
MTH	J	F	M	A	M	J	J	A	S	O	N	X

6.5.2 Sensor Unit - Remove and Refit

Replacement parts

102714

Sensor (includes flow diverter and O rings)

1. Detach the cable connector (A) from the sensor (B).
2. Unscrew the sensor from its location.
3. Discard the expired sensor and flow diverter (C).
4. Insert the cable connector into the new sensor (B).
5. Screw the new flow diverter (C) onto the new sensor, and fit new O rings.
6. Fit the assembly into the absorber.
7. Calibrate the new sensor, see section 5.
8. Dispose of the used components according to hospital regulations and relevant national legislation.

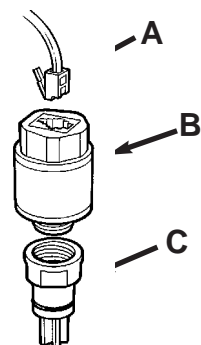

7. APPENDIX

APPENDIX 1

Care of Back-up Battery

CAUTION

Damage may occur if the battery is allowed to remain in a discharged state.

Never discharge the battery to below 10.2 volts.

A. Battery installed in ventilator

The battery must be charged before the machine is released for use with an 14 hour charge from the ventilator's internal power supply (ventilator connected to the mains supply, but not running).

Note that the mains power indicator on the front panel will show a yellow light during charging.

Subsequently the recharge periods for a battery on a ventilator in store are similar to those in B, below.

Batteries in machines in normal use will be kept charged by the internal power supply.

Note that the Low Battery Alarm indicator may be displayed if automatic recharging is taking place as the ventilator is in use.

B. Battery care/storage requirements.

During storage, batteries will require a periodic recharge, the frequency of which is determined by the storage temperature, which must not exceed 50°C (120°F).

Storage temperature	Recharge period
38 to 50°C (100 to 122°F)	1 month
21 to 38°C (70 to 100°C)	3 months
7 to 21°F (45 to 70°F)	6 months
0 to 7°C (32 to 45°F)	9 months
-5 to 0°C (23 to 32°F)	12 months

Duration - recharge until the charge current is less than 25 mA (typically overnight).

It is recommended that at each charge an updated label is affixed to the unit to indicate date of the last charge.

C. Disposal of used batteries

Follow all hospital, local, state and federal regulations.

Note

Removal/replacement of battery must only be undertaken by a trained technician

APPENDIX

APPENDIX 2

On-screen Menus

NOTE:

1. All selection or changes in the menu are followed by a "CONFIRM" message prompt on the screen, and accompanied by a "BEEP" (user volume set)
2. The selected text or option will invert in colour
3. User settings menus only activate in Standby mode.
4. Clock menu, Upgrade menu, Diagnostic menu only activate in Standby mode.
5. Special Modes on-screen tab only activates in Spontaneous mode
6. Adult default settings
 - VT=600 mL
 - RATE=10 bpm
 - IE RATIO=1:2
 - Plimit=38 cmH₂O
 - Ptarget=10 cmH₂O
7. Paediatric default settings
 - VT=150 ml
 - RATE=15 BPM
 - IE RATIO=1:2
 - Plimit=38 cmH₂O
 - Ptarget=10 cmH₂O

Menu Structure

Main Menu

- EXIT MENUS
- O2 MONITOR & SPIROMETRY
- FRESH GAS COMPENSATION: ON
- SPECIAL MODES
- WAVEFORM
- ALARM SETTINGS
- GAS MIXTURE: O2+AIR
- USER SETTINGS
- SERVICE MENU

<p>O2 Monitor & Spirometry</p> <p>ESCAPE FROM MENU O2 MONITOR: on CALIBRATION: 100% HIGH ALARM SET: 105 LOW ALARM SET: 18 SPIROMETER: on SPIRO CALIBRATION: 0 L/min</p>	<table style="width: 100%; border-collapse: collapse;"> <tr> <td style="width: 30%;"></td> <td style="width: 30%;">off / on</td> <td style="width: 40%;">(Toggle option)</td> </tr> <tr> <td></td> <td>21 / 100%</td> <td>(Toggle option)</td> </tr> <tr> <td></td> <td>19 -105</td> <td>(Integer)</td> </tr> <tr> <td></td> <td>18 - 99</td> <td>(Integer)</td> </tr> <tr> <td></td> <td>off / on</td> <td>(Toggle option)</td> </tr> <tr> <td></td> <td>0 L/min / 10 L/min</td> <td>(Toggle option)</td> </tr> </table>		off / on	(Toggle option)		21 / 100%	(Toggle option)		19 -105	(Integer)		18 - 99	(Integer)		off / on	(Toggle option)		0 L/min / 10 L/min	(Toggle option)																																										
	off / on	(Toggle option)																																																											
	21 / 100%	(Toggle option)																																																											
	19 -105	(Integer)																																																											
	18 - 99	(Integer)																																																											
	off / on	(Toggle option)																																																											
	0 L/min / 10 L/min	(Toggle option)																																																											
<p>Fresh Gas Compensation</p> <p>ON / OFF</p>	<table style="width: 100%; border-collapse: collapse;"> <tr> <td style="width: 30%;"></td> <td style="width: 30%;">off/on</td> <td style="width: 40%;">(Toggle option)</td> </tr> </table>		off/on	(Toggle option)																																																									
	off/on	(Toggle option)																																																											
<p>Special Modes</p> <p>ESCAPE FROM MENU SUPPORT MODE: none TRIGGER: 5 L/min SIGH TO BREATH RATIO: 1:50</p>	<table style="width: 100%; border-collapse: collapse;"> <tr> <td style="width: 30%;"></td> <td style="width: 30%;">Support Mode pick list</td> <td style="width: 40%;"></td> </tr> <tr> <td></td> <td>none</td> <td></td> </tr> <tr> <td></td> <td>pressure</td> <td></td> </tr> <tr> <td></td> <td></td> <td>Trigger pick list</td> </tr> <tr> <td></td> <td></td> <td>0.2 L/min</td> </tr> <tr> <td></td> <td></td> <td>0.3 L/min</td> </tr> <tr> <td></td> <td></td> <td>0.4 L/min</td> </tr> <tr> <td></td> <td></td> <td>0.5 L/min</td> </tr> <tr> <td></td> <td></td> <td>1.0 L/min</td> </tr> <tr> <td></td> <td></td> <td>1.5 L/min</td> </tr> <tr> <td></td> <td></td> <td>2.0 L/min</td> </tr> <tr> <td></td> <td></td> <td>2.5 L/min</td> </tr> <tr> <td></td> <td></td> <td>3.0 L/min</td> </tr> <tr> <td></td> <td></td> <td>4.0 L/min</td> </tr> <tr> <td></td> <td>Sigh to Breath</td> <td></td> </tr> <tr> <td></td> <td>Ratio pick list</td> <td></td> </tr> <tr> <td></td> <td>1:50</td> <td></td> </tr> <tr> <td></td> <td>2:50</td> <td></td> </tr> <tr> <td></td> <td>3:50</td> <td></td> </tr> <tr> <td></td> <td>4:50</td> <td></td> </tr> </table>		Support Mode pick list			none			pressure				Trigger pick list			0.2 L/min			0.3 L/min			0.4 L/min			0.5 L/min			1.0 L/min			1.5 L/min			2.0 L/min			2.5 L/min			3.0 L/min			4.0 L/min		Sigh to Breath			Ratio pick list			1:50			2:50			3:50			4:50	
	Support Mode pick list																																																												
	none																																																												
	pressure																																																												
		Trigger pick list																																																											
		0.2 L/min																																																											
		0.3 L/min																																																											
		0.4 L/min																																																											
		0.5 L/min																																																											
		1.0 L/min																																																											
		1.5 L/min																																																											
		2.0 L/min																																																											
		2.5 L/min																																																											
		3.0 L/min																																																											
		4.0 L/min																																																											
	Sigh to Breath																																																												
	Ratio pick list																																																												
	1:50																																																												
	2:50																																																												
	3:50																																																												
	4:50																																																												
<p>Waveform</p> <p>ESCAPE FROM MENU SECOND WAVEFORM: off</p>	<table style="width: 100%; border-collapse: collapse;"> <tr> <td style="width: 30%;"></td> <td style="width: 30%;">Second waveform pick list</td> <td style="width: 40%;"></td> </tr> <tr> <td></td> <td>off</td> <td></td> </tr> <tr> <td></td> <td>vol. vs time</td> <td></td> </tr> <tr> <td></td> <td>vol. vs press.</td> <td></td> </tr> </table>		Second waveform pick list			off			vol. vs time			vol. vs press.																																																	
	Second waveform pick list																																																												
	off																																																												
	vol. vs time																																																												
	vol. vs press.																																																												
<p>Alarm settings</p> <p>ALARM MENU ESCAPE FROM MENU ALARM MODE : default HIGH TIDAL VOLUME: off VM MIN: 0.3 L VM MAX: 0.9 L VT MIN: 300 mL VT MAX: 900 mL APNOEA ALARM LIMIT: 0.3 cmH2O ALARM VOLUME: 50%</p>	<table style="width: 100%; border-collapse: collapse;"> <tr> <td style="width: 30%;"></td> <td style="width: 30%;">default / user</td> <td style="width: 40%;">(Toggle option)</td> </tr> <tr> <td></td> <td>off / on</td> <td>(Toggle option)</td> </tr> <tr> <td></td> <td>0.0 - 7.4</td> <td>(Integer)</td> </tr> <tr> <td></td> <td>0.1 - 7.5</td> <td>(Integer)</td> </tr> <tr> <td></td> <td>10 - 1600</td> <td>(Integer)</td> </tr> <tr> <td></td> <td>20 - 2400</td> <td>(Integer)</td> </tr> <tr> <td></td> <td>0.3 - 3.5</td> <td>(Integer)</td> </tr> <tr> <td></td> <td>50 - 100%</td> <td>(Integer)</td> </tr> </table>		default / user	(Toggle option)		off / on	(Toggle option)		0.0 - 7.4	(Integer)		0.1 - 7.5	(Integer)		10 - 1600	(Integer)		20 - 2400	(Integer)		0.3 - 3.5	(Integer)		50 - 100%	(Integer)																																				
	default / user	(Toggle option)																																																											
	off / on	(Toggle option)																																																											
	0.0 - 7.4	(Integer)																																																											
	0.1 - 7.5	(Integer)																																																											
	10 - 1600	(Integer)																																																											
	20 - 2400	(Integer)																																																											
	0.3 - 3.5	(Integer)																																																											
	50 - 100%	(Integer)																																																											
<p>Gas mixture: O2+Air</p> <p>O2+AIR O2+N2O O2+Xe O2+He</p>																																																													
<p>User Settings</p> <p>ESCAPE FROM MENU SELECT SETTINGS SAVE SETTINGS BACK LIGHT LEVEL: 50% VOLUME TYPE: tidal</p>	<table style="width: 100%; border-collapse: collapse;"> <tr> <td style="width: 30%;"></td> <td style="width: 70%;">Select settings</td> </tr> <tr> <td></td> <td>ESCAPE FROM MENU</td> </tr> <tr> <td></td> <td>USER1: CCT1</td> </tr> <tr> <td></td> <td>USER2: CCT2</td> </tr> <tr> <td></td> <td>USER3: CCT3</td> </tr> <tr> <td></td> <td>USER4: CCT4</td> </tr> <tr> <td></td> <td>USER5: CCT5</td> </tr> <tr> <td></td> <td>ADULT DEFAULT</td> </tr> <tr> <td></td> <td>PAEDIATRIC DEFAULT</td> </tr> <tr> <td></td> <td>Save settings</td> </tr> <tr> <td></td> <td>ESCAPE FROM MENU</td> </tr> <tr> <td></td> <td>USER1: CCT1 CONFIRM: CCT1</td> </tr> <tr> <td></td> <td>USER2: CCT2 CONFIRM: CCT2</td> </tr> <tr> <td></td> <td>USER3: CCT3 CONFIRM: CCT3</td> </tr> <tr> <td></td> <td>USER4: CCT4 CONFIRM: CCT4</td> </tr> <tr> <td></td> <td>USER5: CCT5 CONFIRM: CCT5</td> </tr> <tr> <td></td> <td>Backlight level</td> </tr> <tr> <td></td> <td>0 - 100% (integer)</td> </tr> <tr> <td></td> <td>Volume type</td> </tr> <tr> <td></td> <td>tidal/minute (toggle)</td> </tr> </table>		Select settings		ESCAPE FROM MENU		USER1: CCT1		USER2: CCT2		USER3: CCT3		USER4: CCT4		USER5: CCT5		ADULT DEFAULT		PAEDIATRIC DEFAULT		Save settings		ESCAPE FROM MENU		USER1: CCT1 CONFIRM: CCT1		USER2: CCT2 CONFIRM: CCT2		USER3: CCT3 CONFIRM: CCT3		USER4: CCT4 CONFIRM: CCT4		USER5: CCT5 CONFIRM: CCT5		Backlight level		0 - 100% (integer)		Volume type		tidal/minute (toggle)																				
	Select settings																																																												
	ESCAPE FROM MENU																																																												
	USER1: CCT1																																																												
	USER2: CCT2																																																												
	USER3: CCT3																																																												
	USER4: CCT4																																																												
	USER5: CCT5																																																												
	ADULT DEFAULT																																																												
	PAEDIATRIC DEFAULT																																																												
	Save settings																																																												
	ESCAPE FROM MENU																																																												
	USER1: CCT1 CONFIRM: CCT1																																																												
	USER2: CCT2 CONFIRM: CCT2																																																												
	USER3: CCT3 CONFIRM: CCT3																																																												
	USER4: CCT4 CONFIRM: CCT4																																																												
	USER5: CCT5 CONFIRM: CCT5																																																												
	Backlight level																																																												
	0 - 100% (integer)																																																												
	Volume type																																																												
	tidal/minute (toggle)																																																												
<p>Service</p> <p>See next page</p>																																																													

Service

ESCAPE FROM MENU
LANGUAGE: ENGLISH
PRINT PATIENT DATA
SERIAL MODE: none
CLOCK MENU
UPGRADE MENU
AMBIENT PRESSURE: 988 mBar
DISPLAY HISTORY
*SERVIS PIN: 0
*ENGINEER MENU

Language pick list

ENGLISH
ITALIANO
TURKCE
POLSKI
ESPANOL

Serial mode pick list

NONE
Philips
SPACELABS

Clock

ESCAPE FROM MENU	Clock pick list	(integer)
YEAR: 2005	2005 - 2099	(integer)
MONTH: 3	1 - 12	(integer)
DATE: 16	1 - 31	(integer)
DOW: 3	1 - 7 (1 = Monday)	(integer)
HOUR: 9	0 - 23	(integer)
MINUTE: 57	0 - 59	(integer)
UPDATE CLOCK		
DAYLIGHT SAVING: off	off / on	(toggle option)

Upgrade

ESCAPE FROM MENU
I/O HARDWARE: 2
I/O FIRMWARE: v0.47 [Build 68]
MAIN FIRMWARE: v0.92 [Build 32]
REGISTRATION KEY: unknown
UPGRADE FIRMWARE: unavailable
ADD NEW FEATURE: unavailable

History Display

ESCAPE FROM MENU
MANUFACTURER DATE : 03/03/05
TOTAL HOURS RUN: 100
LAST SERVICE DATE: 13/08/04
HOURS SINCE SERVICE : 100
DRIVE VALVE CYCLES: 1253
PATIENT VALVE CYCLES: 822
CUTOFF VALVE CYCLES: 72

**NOTE
Service PIN
Engineer Menu*

Sub-menus are not accessible by users.

APPENDIX

APPENDIX 3

AV-S Ventilator Spirometry System

Ventilator Spirometry Measurement

The AV-S ventilator drive gas and spirometry system uses a total of three mass flow gas sensors to monitor and then independently measure the gas flows within the ventilator and breathing system. This ensures that correct volumes are delivered to the patient. These monitors are measuring firstly in the ventilator delivery control system, and secondly in the patient breathing system.

During use of the ventilator the user will set a required tidal volume and at the first breath the ventilator will use its pre-calibrated delivery flow rate valve settings to set the proportional delivery valve position to deliver the requested tidal volume.

To confirm that the correct flow rate (tidal volume) is being delivered by the ventilator delivery system an internal flow sensor (a Honeywell AWM43300V mass flow sensor), monitors the delivered flow rate and makes adjustments every 30 ms using proportional regulation.

As this sensor is always measuring the known drive gas rather than breathing system gas the volumes measured will always be independent of breathing system gas composition. This system ensures accurate delivery volume from the ventilator control unit.

To monitor for correct delivery volumes in the breathing system there are two breathing system mass flow sensors (Honeywell AWM 720P1 spirometers). One sensor is located in the inspiratory limb, and one in the expiratory limb. Measurements are taken from these sensors to determine the actual delivered and exhaled gas volumes in the breathing system. This enable measurements to be made to compensate for fresh gas flow, compliance losses and possible breathing system leaks. During the inspiratory cycle the inspiratory flow sensor measures the gas volume delivered to the patient.

The flow sensor output is read at least every 2 msec and then five sets of readings are averaged and the averaged value is sent every 10 ms to the processor for calculation of the volume delivered to the patient.

This delivered volume will consist of the volume delivered from the ventilator bellows plus the fresh gas flow from the anaesthetic machine fresh gas supply, minus any compliance loss and minus any leak. This gives a total actual inspired tidal volume.

A similar measurement method is used for the exhaled volume. During the exhalation period the measured exhaled volume is subtracted from the inspired volume, and at the end of exhalation.

A negative (more gas coming out) volume indicates that fresh gas has increased the delivered volume.

A positive volume (less gas coming out) indicates a leak in the circuit.

The ventilator control system will then adjust the next delivered tidal volume, up to a maximum of 100 ml. This will bring the delivered volume to exactly as set.

If the variation between set and delivered is greater than the maximum rate of change allowed, the adjustment will occur gradually over several breaths.

The displayed volume is the average of the inspiratory and expiratory volumes. If this value is less or more than 50% of set volume, a low or high volume alarm is given.

Breathing System Gas Composition

Gas flow measurements are affected by the breathing system gas composition. To compensate for these effects the ventilator has

- a) a gas composition setting whereby the user is able to select the gasses being delivered, i.e. oxygen/air, oxygen/nitrous oxide etc,
- b) an oxygen monitor;

Thus the ventilator knows the overall oxygen concentration and the majority of the remaining gas composition.

APPENDIX

Altitude Effects

Gas flow measurements are also affected by atmospheric pressure, in a linear relationship.

To compensate for altitude effects an ambient pressure sensor is available. When the spirometers are calibrated for zero flow the ambient pressure is recorded so that the measured volume may be adjusted. The measured volume is multiplied by the ratio of P_{amb} to P_{cal} ; where P_{amb} is the latest ambient pressure and P_{cal} is the ambient pressure recorded when the spirometers were calibrated at zero flow.

Carrier Gas Effects

The effect of air as the diluent gas is different to that of nitrous oxide and as the ventilator includes only an oxygen monitor, the additional information of gas being ventilated is included to increase available accuracy. In the event of the wrong gas selection being made by the user, the error in delivered volume could reach up to approximately 7%. This possible variation is of no known clinical disadvantage.

Anaesthetic Agent Effects

The addition of anaesthetic agent is known also to increase the spirometry readings depending on the agent and its concentration by up to approximately 2%. Again this minor volume measurement variation is of no known clinical disadvantage and is therefore not compensated for other than that due to oxygen variation due to the percentage change.

Water Vapour Effects

Water vapour volumes in the breathing gas are not detectable in normal breathing system dynamics.

Additional Features

Additional spirometry features available for selection by the user are the ability to turn off the automatic compliance and fresh gas compensation and also the feedback provided by the oxygen monitor. In this event, the ventilator relies on the basic delivery look up table and the internal flow sensor to confirm delivery volumes as

near as possible, under the circumstances. Accuracies for spirometry measurement are

>300 ml	± 10%
>100 ml <300 ml	± 20%
<100 ml	± 50%.

Flow sensor description

The microbridge mass airflow sensor operates on the theory of heat transfer. Mass airflow is directed across the surface of the sensing elements. Output voltage varies in proportion to the mass air or other gas flow through the inlet and outlet ports of the package.

The specially designed housing precisely directs and controls the airflow across the microstructure sense element. The microbridge mass airflow sensor has a unique silicon chip based on advanced microstructure technology. It consists of a thin-film, thermally isolated bridge structure containing heater and temperature sensing elements. The bridge structure provides a sensitive and fast response to the flow of air or other gas over the chip.

Dual sensing elements positioned on both sides of a central heating element indicate flow direction as well as flow rate. Laser trimmed thick film and thin film resistors provide consistent interchangeability from one device to the next.

The microbridge mass airflow sensor uses temperature-sensitive resistors deposited within a thin film of silicon nitride. They are suspended in the form of two bridges over an etched cavity in the silicon. The chip is located in a precisely dimensioned airflow channel to provide a repeatable flow response.

Highly effective thermal isolation for the heater and sensing resistors is attained by etching the cavity space beneath the flow sensor bridges. The small size and thermal isolation of the microbridge mass airflow sensor are responsible for the extremely fast response and high sensitivity to flows.

APPENDIX

Dual Wheatstone bridges control airflow measurement - one provides closed loop heater control, the other contains the dual sensing elements.

The heater circuit minimizes shift due to ambient temperature changes by providing an output proportional to mass flow. The circuit keeps the heater temperature at a constant differential (160°C) above ambient air temperature which is sensed by a heat-sunk resistor on the chip.

The ratiometric voltage output of the device corresponds to the differential voltage across the Wheatstone bridge circuit.

Sensor flow characteristics

The graph shown below is a typical flow versus resistance graph for the Honeywell spirometer head units for the flow range showing typical hysteresis between up and down flow measurements (and repeatability).

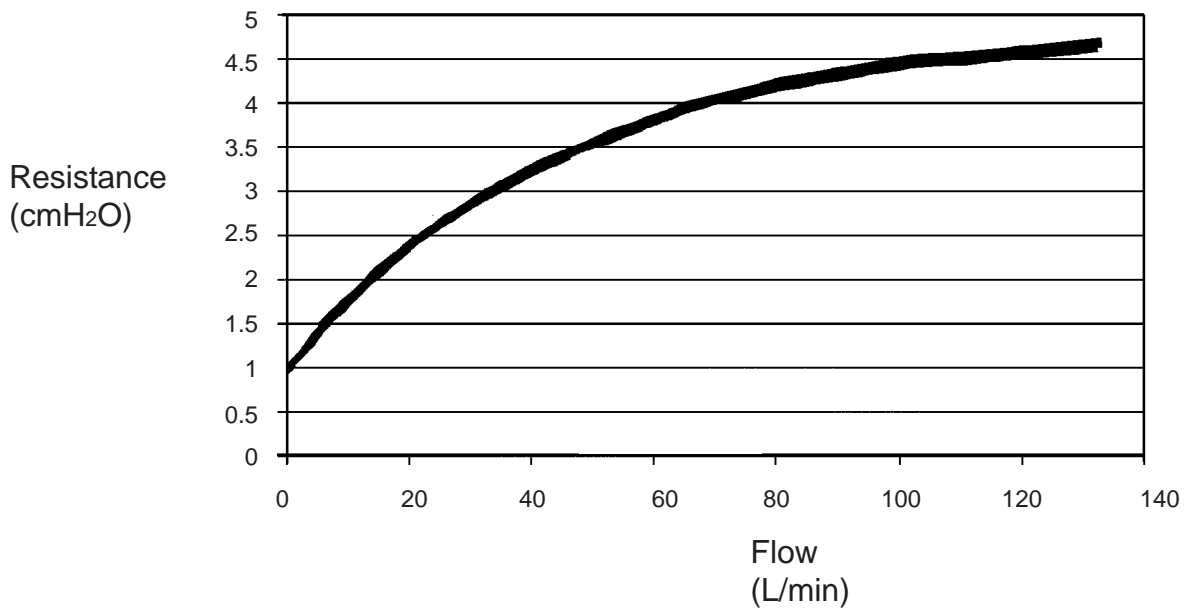

Paragon Service
W. Bennet Sreet
Saline
MI 48176

Doc. No. A2 0105UI
July 2005

Manufactured by:
Penlon Limited
Abingdon
UK